

A  
Project Report  
on  
**PV ARRAY RECONFIGURATION UNDER PARTIAL  
SHADING CONDITION**

*Submitted in partial fulfilment of the  
requirement for the award of the  
Degree of*

**BACHELOR OF TECHNOLOGY**

*in*

**ELECTRICAL ENGINEERING**

*by*

**Faiz Ahmad (1615105010)  
Abhishek Rai (1615103002)**

*Under the Guidance of*  
Dr. Gitanjali Mehta  
(Associate Professor, Electrical Engg.)



**SCHOOL OF ELECTRICAL, ELECTRONICS AND COMMUNICATION  
ENGINEERING  
May, 2020**

## **DECLARATION**

We declare that the work presented in this report titled “**PV array reconfiguration under partial shading condition**”, submitted to the Department of Electrical Engineering, Galgotias University, Greater Noida, for the Bachelor of Technology in Electrical Engineering is our original work. We have not plagiarized unless cited or the same report has not submitted anywhere for the award of any other degree. We understand that any violation of the above will be cause for disciplinary action by the university against us as per the University rule.

**Place: Greater Noida**

**Date: 15-05-2020**

**Signature of the Student**

\_\_\_\_\_

Faiz Ahmad (1615105010)

\_\_\_\_\_

Abhishek Rai (1615103002)



**School of Electrical, Electronics and Communication Engineering**  
**CERTIFICATE**

This is to certify that the project titled “**PV array reconfiguration under partial shading condition**” is the bonafide work carried out by Faiz Ahmad, Abhishek Rai students, during the academic year 2019-20. We approve this project for submission in partial fulfilment of the requirements for the award of the degree of Bachelor of Technology in Electrical Engineering, Galgotias University.

Dr. Gitanjali Mehta  
Project Guide

**The Project is Satisfactory / Unsatisfactory.**

\_\_\_\_\_  
Internal Examiner (s)

\_\_\_\_\_  
External Examiner

Approved by

\_\_\_\_\_  
Dean

## ACKNOWLEDGEMENTS

We are grateful to The Department of Electrical Engineering, for giving us the opportunity to carry out this project, which is an integral fragment of the curriculum in Bachelor of Technology program at the Galgotias University, Greater Noida. We would like to express our heartfelt gratitude and regards to our project guide, Dr. Gitanjali Mehta, Associate Professor, School of Electrical, Electronics and Communication Engineering, for his unflagging support and continuous encouragement throughout the project.

-----

-----

-----

Special thanks to our Dean Prof. B. Mohapatra School of Electrical, Electronics and Communication engineering for -----

-----

We are also obliged to the staff of School of Electrical, Electronics and Communication Engineering for aiding us during the course of our project. We offer our heartiest thanks to my friends for their help in collection of data samples whenever necessary. Last but not the least; we want to acknowledge the contributions of our parents and family members, for their constant and never-ending motivation.

-----

-----

-----

## **ABSTRACT**

In this report, a complete analysis is being accomplished on solar photovoltaic (SP) modules configuration under different partial shaded conditions. The primary goal of this report is to design, study & analyse the efficacy of various photovoltaic (PV) topologies below different partial shadow scenarios. The main focus is to enhance the efficacy of PV pattern by decreasing dissimilarity losses and to choose the utmost relevant PV pattern topologies that gives the better outcomes. A complete investigation is accomplished on total applicable solar array configuration. Under different feasible shadow conditions the performance & output characteristic of these array conformation are studied & compared. In a solar PV array there may be possibilities that some shadow may fall on some of cell or module. The PV characteristic become more complicated with various apexes or peaks under PSC. Due to partial shading the efficiency of photovoltaic system reduces by adversely affecting the irradiance perceived by photovoltaic cell. The shading in PV system may create numerous unwanted consequences. Whenever the shading happens, the energy achieved from the PV system is too less than actual output power due the mismatch losses of PV system. In this context various configuration techniques are recited i.e. series-parallel (SP), Bridge-linked(BL), Total-cross-tied(TCT), Honey-comb(HC) etc. The simulation of all proposed novel structure has been investigated on MATLAB/Simulink environment.

# TABLE OF CONTENTS

<b>Title</b>	<b>Page no</b>
Acknowledgements	iii
Abstract	iv
Table of Contents	v
List of Figures	vi
List of Tables	vii
Glossary	viii
<b>1. Introduction</b>	<b>1</b>
<b>2. System Description</b>	<b>3</b>
2.1. Modelling of photovoltaic module under PSC	3
2.2. Modelling of PV cell	4
2.3. Mathematical modelling of PV string	5
2.4. Series-parallel configuration	6
2.5. Total-cross-tied configuration	7
2.6 Bridge-linked configuration	8
<b>3. Conclusions and Future Research Works</b>	<b>10</b>
5.1. Conclusions	10
<b>4. References</b>	<b>11</b>

## LIST OF FIGURES

<b>Figure no.</b>	<b>Page no.</b>
Figure.1 Partial shading of PV module.....	(3)
Figure.2 Equivalent circuit of PV cell.....	(5)
Figure.3 Simulation in MATLAB/Simpower.....	(5)
Figure.4 P-V & I-V characteristics of SP configuration.....	(6)
Figure 5 P-V & I-V characteristics of TCT configuration.....	(7)
Figure.6 P-V & I-V characteristic of BL configuration .....	(8)

## **GLOSSARY**

PSC	Partial shading condition
PV	Photovoltaic
SPV	Solar photovoltaic
SP	Series-parallel
TCT	Total-cross-tied
BL	Bridge-linked



# 1. INTRODUCTION

Photovoltaic (PV) system is observed as the eminent & inexhaustible source of energy since sun ray is available in every place which is abundant in nature. It is costless & energy produced by PV system don't harm the environment i.e sustainable in nature. Even though, PV panels rate is decreasing every next year also the government provide subsidies to install PV panels to their house & generate electricity. Solar photovoltaic cell (SPV) has been booming rapidly as a source of renewable energy in the world to meet the load demand. Solar PV cell are adopted globally due to their non-polluting & eco-friendly nature which having several profitable implementation in commercial & household application. The non-renewable energy resource i.e. fossil fuels are exhausting rapidly. To overcome with this issue renewable energy would be a better source of energy which is abundant in nature and inexhaustible & it can be obtain easily & free of cost. The output power of PV system rely on several parameters such as : temperature gradient, solar radiance, partial shading etc.

Amid of all above parameters partial shading is the main cause of decreasing the efficacy. Some other cause of PSC may be from neighbouring house, trees, dirt, clouds etc. A several number of module are combined in series & parallel to form an array to meet the power demand. Shading creates blockage of direct solar radiance due to which there is loss of power. Due to shading solar cell become equal to resistor that absorb the energy produced by nearby cells. Now, that consumed energy is transformed into heat that increases the temperature of cell & degrade it. This phenomenon is called Hotspot effect. By employing bypass diode this problem can be fixed. Bypass diode brings the minimum resistance pathway which is coupled in antiparallel direction of solar cell.

Although, there are several technique to overcome with losses due to PS condition: Maximum power point technique (MPPT), PV system architecture, Converter topologies, PV array reconfiguration etc. In this PV array reconfiguration method is proposed which is most conventional method that overcome the shading losses. Several interconnections pattern of PV module like as Series-parallel (SP), Bride-linked (BL) & Total-cross-tied (TCT) have been considered in this paper. We can get TCT & BL network by applying interconnection with in strings of PV module in SP pattern. Studies have proven among all those connection TCT configuration gives outstanding performance followed by BL & HC in most of PS conditions. The modelling & simulation of PV array configurations were carried on using MATLAB/Simulink & their efficacy were analysed. This paper state a MATLAB-based designing & simulation technique useful for examining & analysing of current-voltage & Power-Voltage attributes of a PV pattern below PSC. Many research worker suggested topologies to investigate and analyse the result of shading on various PV array topologies to decrease the losses & to identify the perfect PV array topology that gives the maximum efficacy. The PV array topologies of SP, BL, & TCT were studied & examined. The author analysed that by selecting the appropriate configuration design as per shading norm the more energy could be obtain. Overall, in almost PS pattern the output power achieved depicts that TCT configuration gives the excellent performance.

So, the comparison with prior research performed to this area the primary goal of this report is to deliver a complete analysis which concede the total possible PV pattern configuration below PSC. The idea for this plan comes first by designing the whole PV array topologies with various size & after then examining their efficacy under various PSC. By determining these scenarios it will give the best method to choose the better configuration under PSC that enhance the efficacy.

## 2. SYSTEM DESCRIPTION

This segment represent the technique for establishing the introduced method for the connection of module in proposed configuration of partially shaded array. Entire simulation is done in MATLAB software.

### 2.1 Modelling of Photovoltaic Module Under PSC

Depending on the demand the solar module is inter-connected in cascade-parallel to increase the voltage & current capacity appropriately. The photovoltaic module are chosen from Simscape library and connected together. PV module consist of three terminals in which one terminal is for radiance while two other is for positive and negative terminal of module & a bypass diode is linked with every panel in antiparallel manner.



Fig. 1: Partial shading of PV module

## 2.2 Modelling of PV cell.

The solar cell voltage ( $V_c$ ) is the mathematical relation of current ( $I_{ph}$ ) that is based on solar irradiance which could be formulated in equation (1),

$$V_c = \frac{AkT_c}{e} \ln \left( \frac{I_{ph} + I_o + I_c}{I_o} \right) - R_s I_c \quad (1)$$

As the photovoltaic cell change with photovoltaic radiance degree  $S_c$  the operational temperature  $T_c$  of photovoltaic cell variance. This outcome is incorporated from temperature rectification factor  $C_{tv}$  &  $C_{ti}$  employing equation (2) ,

$$C_{tv} = 1 + \beta t (T_a - T_x) \& C_{ti} = 1 + \frac{\gamma t}{S_c} (T_x - T_a) \quad (2)$$

The irradiance degree ( $S_x$ ) outcome to the voltage & current could be calculated for rectification factor  $C_{sv}$  and  $C_{si}$  expressed in equation (3) ,

$$C_{sv} = 1 + \beta t a s (S_x - S_c) \& C_{si} = 1 + \frac{1}{S_c} (S_x - S_c) \quad (3)$$

Where the  $S_c$  and  $S_x$  depicts the reference and actual solar radiation level appropriately.

The rectification factor of temperature & solar radiation like as  $C_{tv}$ ,  $C_{ti}$ ,  $C_{sv}$  and  $C_{si}$  are helpful in evaluating the absolute rate for the solar cell voltage ( $V$ ) and current ( $I$ ) that could expressed in equation (4) ,

$$V_{cx} = C_{tv} C_{sv} V_c \& I_{phx} = C_{ti} C_{si} I_{ph} \quad (4)$$

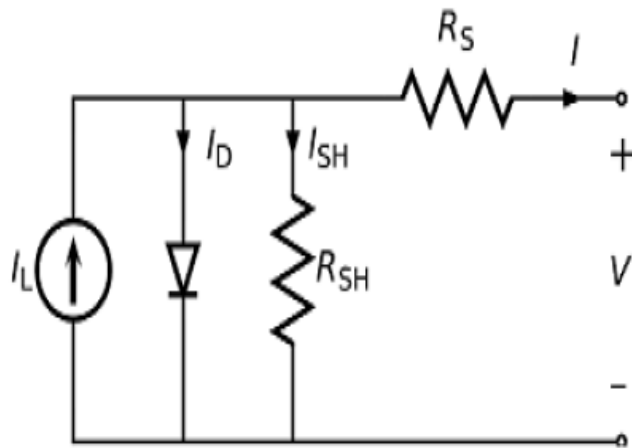

Fig. 2: Equivalent circuit of PV cell

### 2.3 Mathematical modelling of Photovoltaic string.

Solar panel may differ at most if reconfiguration of photovoltaic cell. Whether  $N_s$  PV cell are linked in cascade, solar panel voltage is equivalent into  $N_s$  count with single solar cell voltage and solar panel current that is equivalent to that of each single cell.

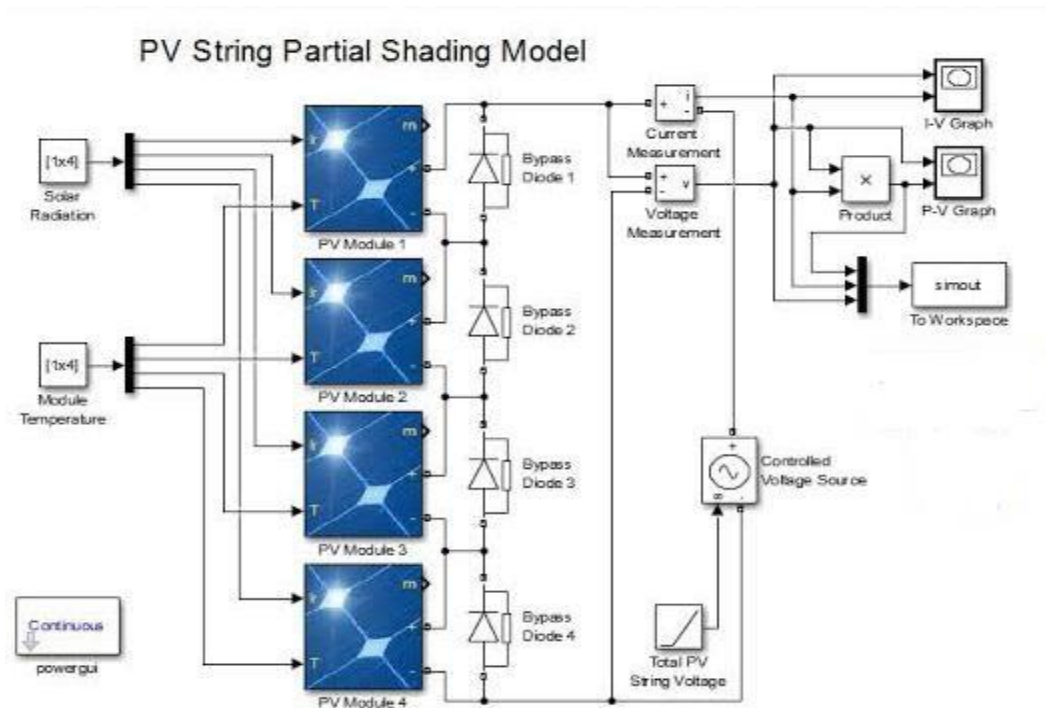

Fig.3: Simulation in MATLAB/Simpower

### 3.4 Series-Parallel (SP) configuration

In Cascade-Parallel photovoltaic topologies the solar modules are firstly inter-connected in cascade to make a sequence pattern to get as per need voltage after this sequence patterns are inter-connected in parallel to get as per need current. The power-voltage and current-voltage attribute below partial shadow pattern for cascade-parallel are demonstrated in fig. respectively. This connection is mostly used & common because it is easy to made and there are no complex connection.

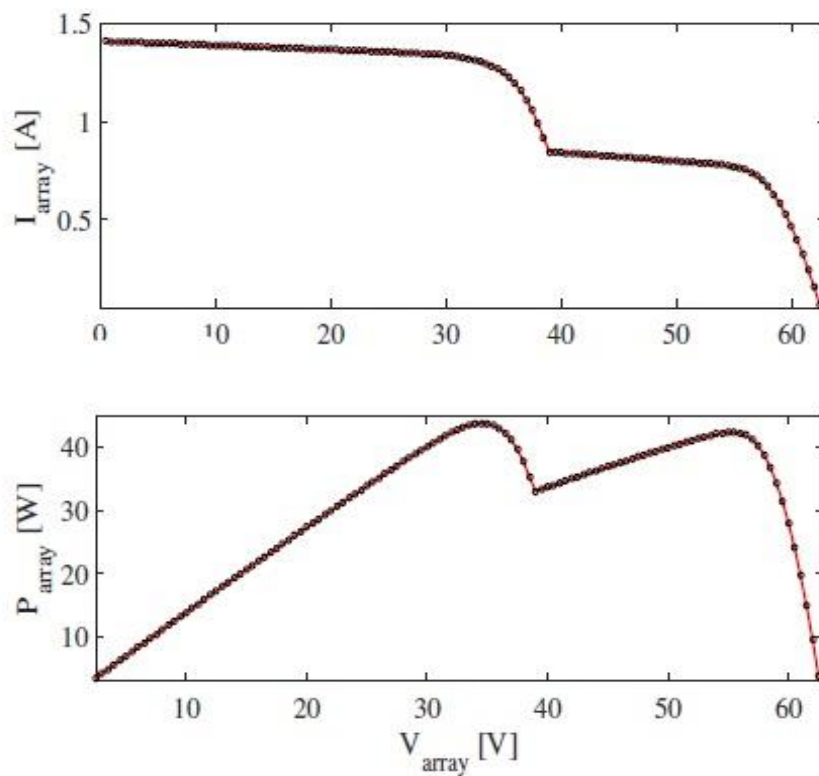

Fig. 4: Current-Voltage (V-I) & Power-Voltage (P-V) characteristic of SP configuration

### 3.4 Total-Cross-Tied Configuration (TCT)

In total-cross-tied every photovoltaic module is connected to its neighbouring PV panel. All the PV panels are cross inter-connected. The figure 5 depicts the P-V & I-V attributes under partial shading condition.

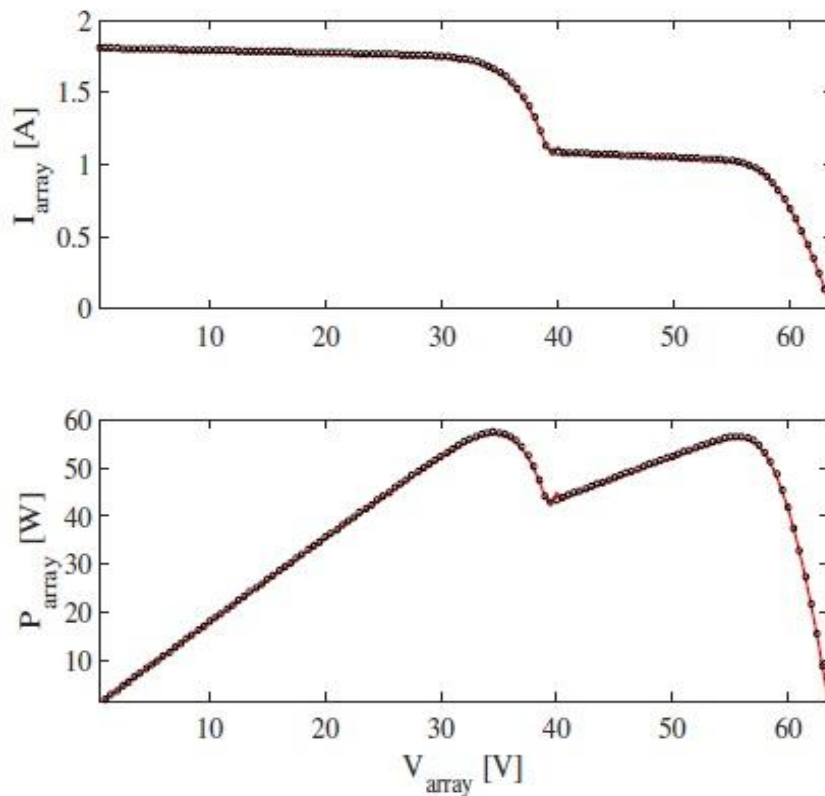

Fig. 5: Current-Voltage (V-I) & Power-Voltage (P-V) characteristic of TCT configuration

### 3.5 Bridge-Linked (BL) Configuration.

Figure 6. depicts the P-V & I-V attributes of Bridge linked configuration under uniform and partial shading condition respectively.

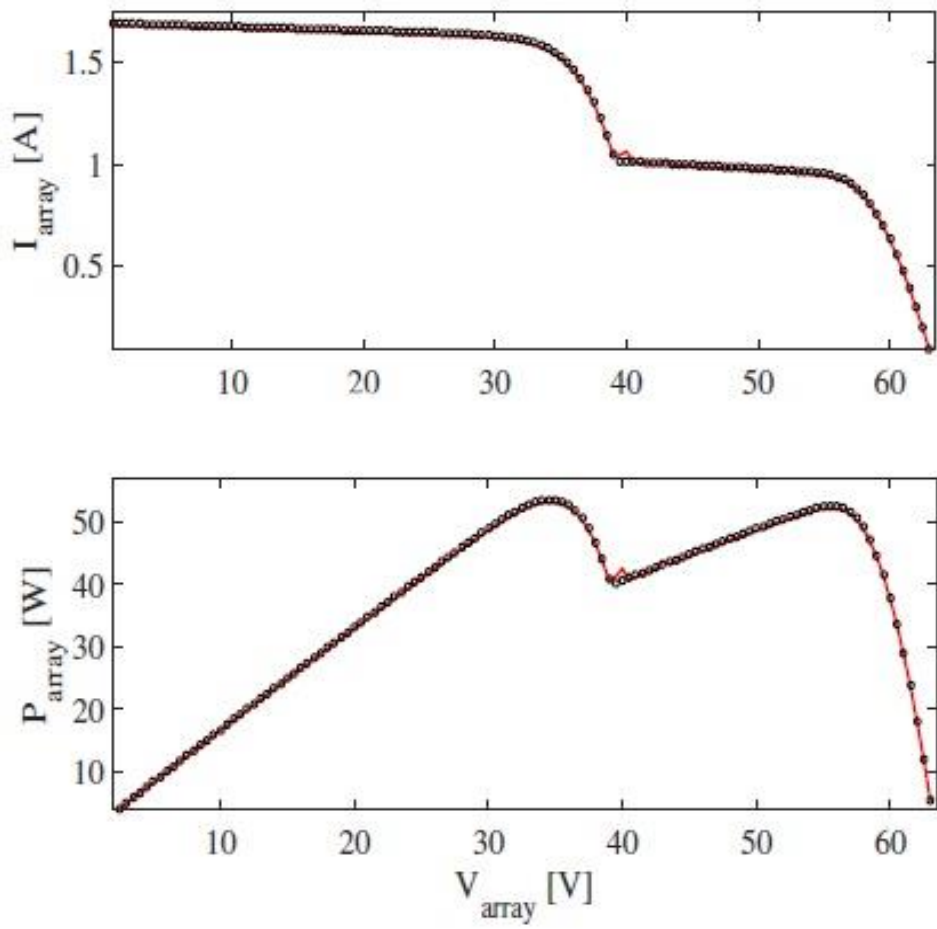

Fig. 6: Current-Voltage (V-I) & Power-Voltage (P-V) characteristic of BL configuration.



## **4. CONCLUSION**

In this report, a complete analysis that proposed almost all photovoltaic topologies under all feasible shading conditions. The result depicts that the efficacy of the PV array configuration are inconstant & based on different type of shading pattern. The stated configuration overwhelm the mismatch losses and simulations were executed in MATLAB to achieve the output power. Finally, this analysis gives an idea how we can apply this PV array topologies under shading conditions.

## 5. REFERENCES

1. Bidram, Ali, Davoudi, Ali, Balog, Robert S., 2012. Control and circuit techniques to mitigate partial shading effects in photovoltaic arrays IEEE J. Photovoltaics 2 (4), 532–546.
2. Bishop, J.W., 1988. Computer simulation of the effects of electrical mismatches in photovoltaic cell interconnection circuits. Sol. Cells 25,73–89.
3. Buddala, S.S., Vemuru, S., Devabhaktuni, V., 2013. Small signal modeling of diode in a parallel module subjected to partial shading. In: IEEE Int. Conference on Electro/Information Technology (EIT).
4. Malathy, S., Ramaprabha, R., 2015. A static PV array architecture to enhance power generation under partial shading conditions. In: IEEE International Conference on PEDS, pp. 341–346.
5. Belhachat, F., Larbes, C., 2015. Modeling, analysis and comparison of solar photovoltaic array configurations under partial shading conditions. Sol. Energy 120, 399–418.