

School of Basic and Applied Sciences

Course Code : BSCP3005

Course Name: Digital System and Application

XOR and XNOR Gates

Contents

- Introduction
- XOR Gate
- XNOR Gate
- Applications

GALGOTIAS
UNIVERSITY

Introduction : XOR Gate

The exclusive-OR (XOR), operator uses the symbol \oplus , and it performs the following logic operation:
$$X \oplus Y = X Y' + X' Y$$

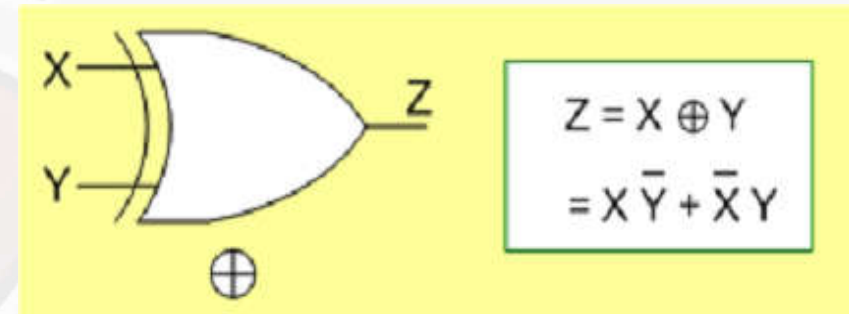

Logic Symbol

GALGOTIAS
UNIVERSITY

School of Basic and Applied Sciences

Course Code : BSCP3005

Course Name: Digital System and Application

XOR Gate

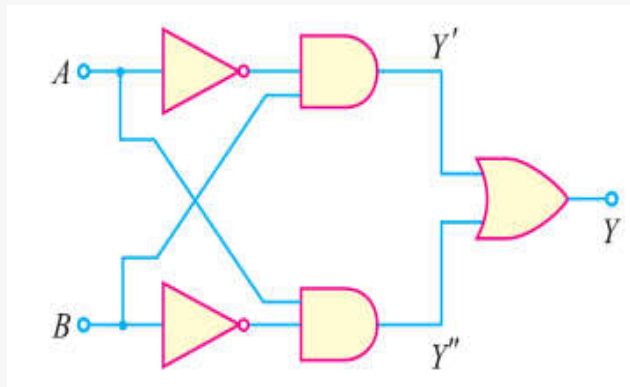

When inputs are same , output will be 0

The result is 1 only when either X is equal to 1 or Y is equal to 1, but not when both X and Y are equal to 1.

X	Y	XOR
0	0	0
0	1	1
1	0	1
1	1	0

Truth Table

UNIVERSITY

School of Basic and Applied Sciences

Course Code : BSCP3005

Course Name: Digital System and Application

Three input XOR Gate

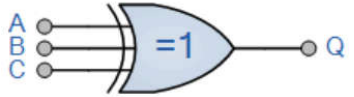
Symbol	Truth Table			
 <p>3-input Ex-OR Gate</p>	C	B	A	Q
	0	0	0	0
	0	0	1	1
	0	1	0	1
	0	1	1	0
	1	0	0	1
	1	0	1	0
	1	1	0	0
	1	1	1	1
	Boolean Expression $Q = A \oplus B \oplus C$	"Any ODD Number of Inputs" gives Q		

$$Q = \overline{A}\overline{B}C + \overline{A}B\overline{C} + A\overline{B}\overline{C} + ABC$$

GOTIAS
UNIVERSITY

School of Basic and Applied Sciences

Course Code : BSCP3005

Course Name: Digital System and Application

XOR Gate Realization using NAND gates

Exclusive-OR Gates are used mainly to build circuits that perform arithmetic operations and calculations especially **Adders** as they can provide a “carry-bit” function or as a controlled inverter, where one input passes the binary data and the other input is supplied with a control signal.

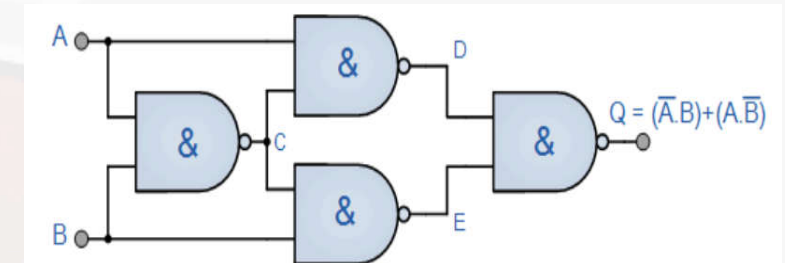

GALGOTIAS
UNIVERSITY

School of Basic and Applied Sciences

Course Code : BSCP3005

Course Name: Digital System and Application

XNOR Gate

The exclusive-NOR (XNOR), operator uses the symbol \odot , and it performs the following logic operation

$$X \odot Y = XY + X'Y' = (X \oplus Y)'$$

Logic Symbol

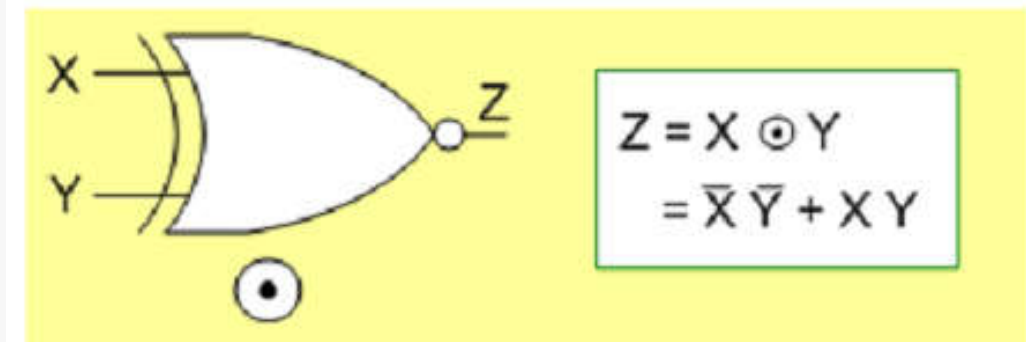

School of Basic and Applied Sciences

Course Code : BSCP3005

Course Name: Digital System and Application

XNOR Gate

Truth Table

X	Y	XNOR
0	0	1
0	1	0
1	0	0
1	1	1

The result is 1 when either both X and Y are 0's or when both are 1's. That is why this gate is often referred to as the **Equivalence** gate.

The truth tables clearly show that the exclusive-NOR operation is the complement of the exclusive-OR.

This can also be shown by algebraic manipulation as follows:

$$\begin{aligned}(X \oplus Y)' &= (XY' + X'Y)' \\ &= (XY')' (X'Y)' = (X' + Y)(X + Y') \\ &= (XY + X'Y') \\ &= X \odot Y\end{aligned}$$

GALGOTIAS
UNIVERSITY

School of Basic and Applied Sciences

Course Code : BSCP3005

Course Name: Digital System and Application

3-input Ex-NOR Gate

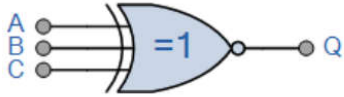
Symbol	Truth Table			
 <p>3-input Ex-NOR Gate</p>	C	B	A	Q
	0	0	0	1
	0	0	1	0
	0	1	0	0
	0	1	1	1
	1	0	0	0
	1	0	1	1
	1	1	0	1
	1	1	1	0
	Boolean Expression $Q = \overline{A \oplus B \oplus C}$	Read as "any EVEN number of Inputs" gives Q		

$$Q = \overline{ABC} + A\overline{B}\overline{C} + A\overline{B}C + \overline{A}BC$$

GOTIAS
UNIVERSITY

School of Basic and Applied Sciences

Course Code : BSCP3005

Course Name: Digital System and Application

XNOR Gate Realization using NAND gates

5 NAND logic gates can be used to realise the XNOR gate

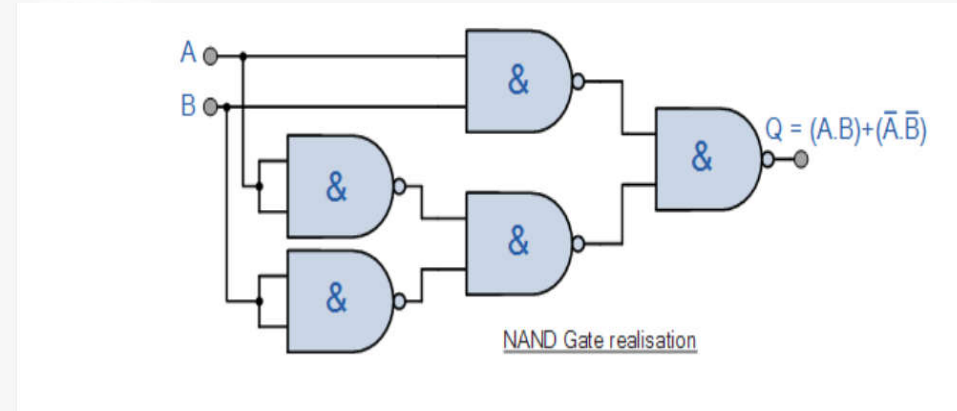

GALGOTIAS
UNIVERSITY

Application of XNOR gate

XNOR gates are used mainly in electronic circuits that perform arithmetic operations and data checking such as *Adders*, *Subtractors* or *Parity Checkers*, etc. As the Ex-NOR gate gives an output of logic level “1” whenever its two inputs are equal it can be used to compare the magnitude of two binary digits or numbers and so Ex-NOR gates are used in Digital Comparator circuits.

School of Basic and Applied Sciences

Course Code : BSCP3005

Course Name: Digital System and Application

References:

- Digital Principles and Applications, A.P. Malvino, D. P. Leach and Saha, 7th Ed., 2011, Tata McGraw Hill
- Digital Fundamentals, Thomas L. Floyd, 11th Ed., 2015, Pearson Education Limited
- Modern Digital Electronics, R P Jain, 4th Ed., 2010, Tata McGraw Hill

GALGOTIAS
UNIVERSITY