

IC555 Timer and applications

Contents

- IC555 timer
- Parts of IC555
- Basic diagram and working of IC555
- Applications of IC555

IC555 Timer

- ✓ The 555 timer IC was first introduced around 1971 by the Signetics Corporation as the SE555/NE555
- ✓ Initially it was called "**The IC Time Machine**"
- ✓ It provided circuit designers with a relatively cheap, stable, and user-friendly integrated circuit for both monostable and astable applications

Parts of IC555 Timer

- Comparators (basically 2 op-amps)
- RS Flip Flop
- Discharging Transistor
- Three 5 ohm registers (That is why it is called IC555 timer)

Parts of IC555 Timer

Comparator Review:

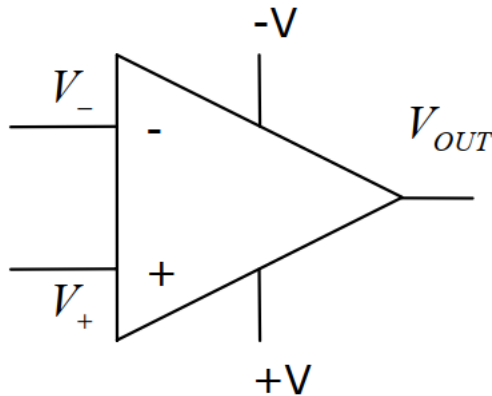

If	V_{OUT} is:
$V_+ > V_-$	$+V$ (i.e. maximum)
$V_+ < V_-$	$-V$ (i.e. minimum)

Comparators

- Feedback loop is not used.
- Decides if one voltage is greater than the other.
- Takes analog voltages and convert them into a series of bits.
- Binary representation of 4 digits give you 16 values (4-bit converter).
- Circuit above is a 1-bit converter:
 - o "0" or "1" output depending which voltage is greater than the other.

Flip Flops:

R-S Flip Flop

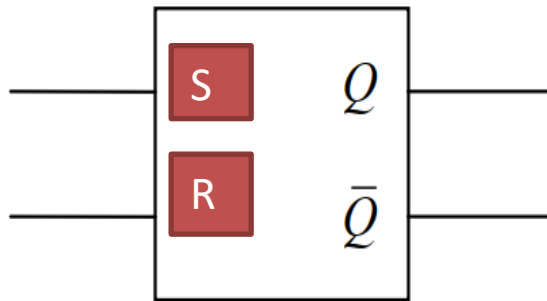

$R \equiv$ Reset

$S \equiv$ Set

Two Values		
TRUE	"1"	Hi Voltage
FALSE	"0"	Lo Voltage

For some circuits:

$$Hi \equiv 5V$$

$$Lo \equiv 0V$$

We use:

$$Hi \equiv +V$$

$$Lo \equiv -V$$

INPUTS		OUTPUTS	
<i>R</i>	<i>S</i>	<i>Q</i>	\bar{Q}
Lo	Lo	Holds last value	
Lo	Hi	Hi	Lo
Hi	Lo	Lo	Hi
Hi	Hi	Not Allowed!	

Once can force the output Q to be "HI" by setting S to "HI". Similarly, one can force the Q output to "LO" by resetting R to "LO". If one drives both R and S to "HI", there is no guarantee about the output's state.

Simplified Block Diagram representation of 555 Timer

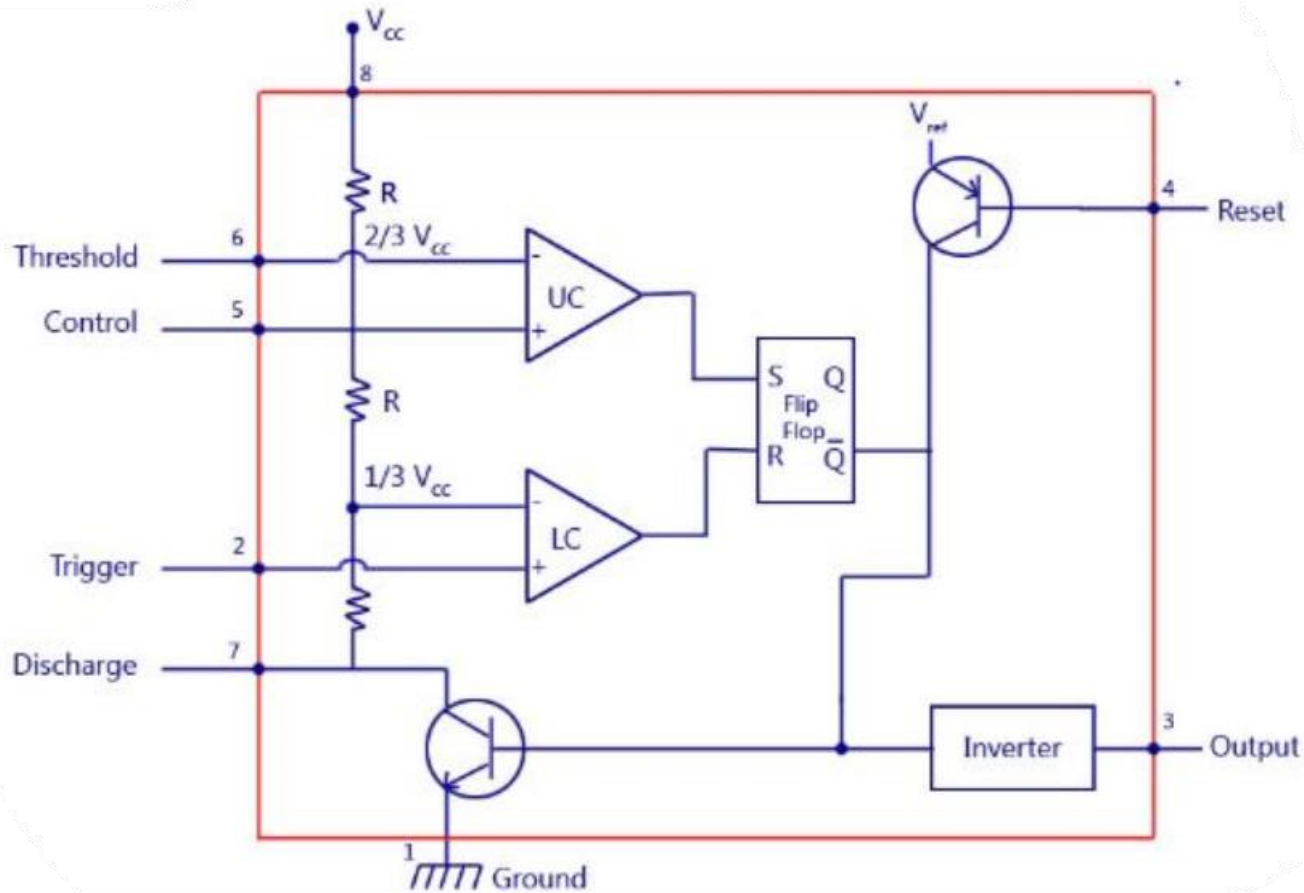

555 Timer Pin Configurations

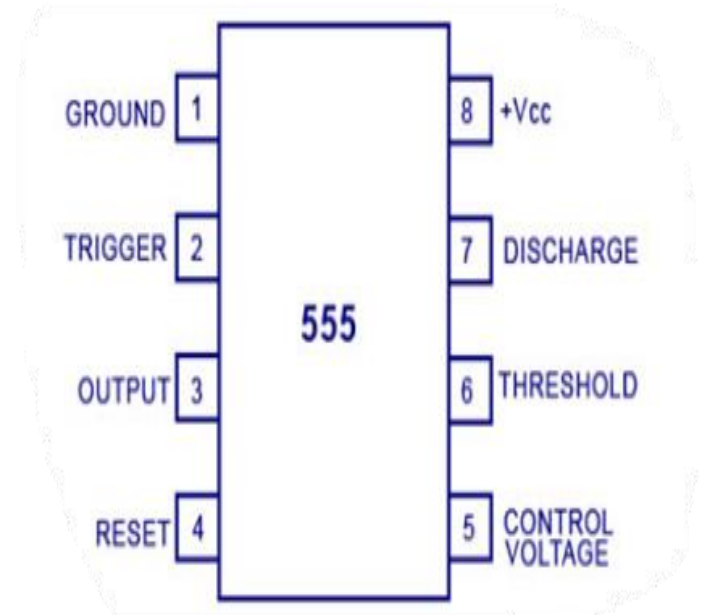
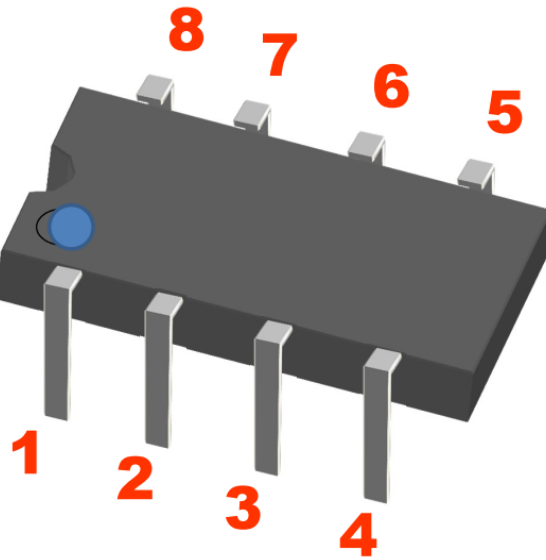

IC555 Timer-Pin description

Pin 1 (Ground):- All voltages are measured w.r.t. this terminal. This is the most negative supply potential of the device

•Pin 2 (Trigger Terminal)

This pin is an inverting input to a lower comparator. This is used to set the flip flop which causes the output to go high

•Pin 3 (Output Terminal)

There are 2 ways to connect load to the output terminal.

Pin 3 & Vcc :- Normally On load

Pin 3 & Ground:- Normally off load

Pin 4 (Reset):- To disable or reset the timer a negative pulse is applied to this pin.

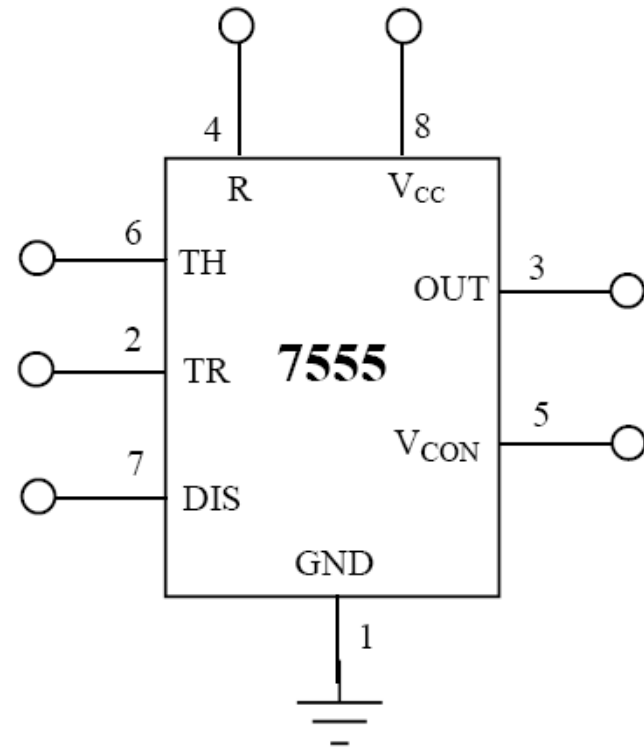

IC555 Timer-Pin description

Pin 5 (Control Voltage)

The function of terminal is to control the threshold and trigger levels. The external voltage or a pot connected to this pin determines the pulse width of the output waveform. *When not in use, it should be connected to ground through a 0.01 μ F capacitor*

to avoid any noise problem.

Pin 6 (Threshold):- This is an input to the upper comparator. Used to reset the flip-flop which drives the output low

Pin 7 (Discharge)

-This pin is connected internally to the collector of transistor and mostly a capacitor is connected between this terminal and ground. It is called discharge terminal because when transistor saturates, capacitor discharges through the transistor. When the transistor is cut-off, the capacitor charges at a rate determined by the external resistor and capacitor.

Pin 8 (Supply Voltage):- A positive supply voltage is applied to this terminal. A supply voltage of + 5 V to + 18 V is applied to this terminal with respect to ground (pin 1)

BASIC TIMING CONCEPTS

- A resistive voltage divider consisting of 3 equal resistors R is employed
- $V_{TH} = 2V_{CC}/3$ for comparator 1.
- Flip Flop is reset whenever threshold goes higher than $2V_{CC}/3$.
- $V_{TL} = V_{CC}/3$
- Flip Flop is set whenever the trigger goes below $V_{CC}/3$.
- In set state output Q is high (approx. equal to V_{CC}) and in reset the output is low

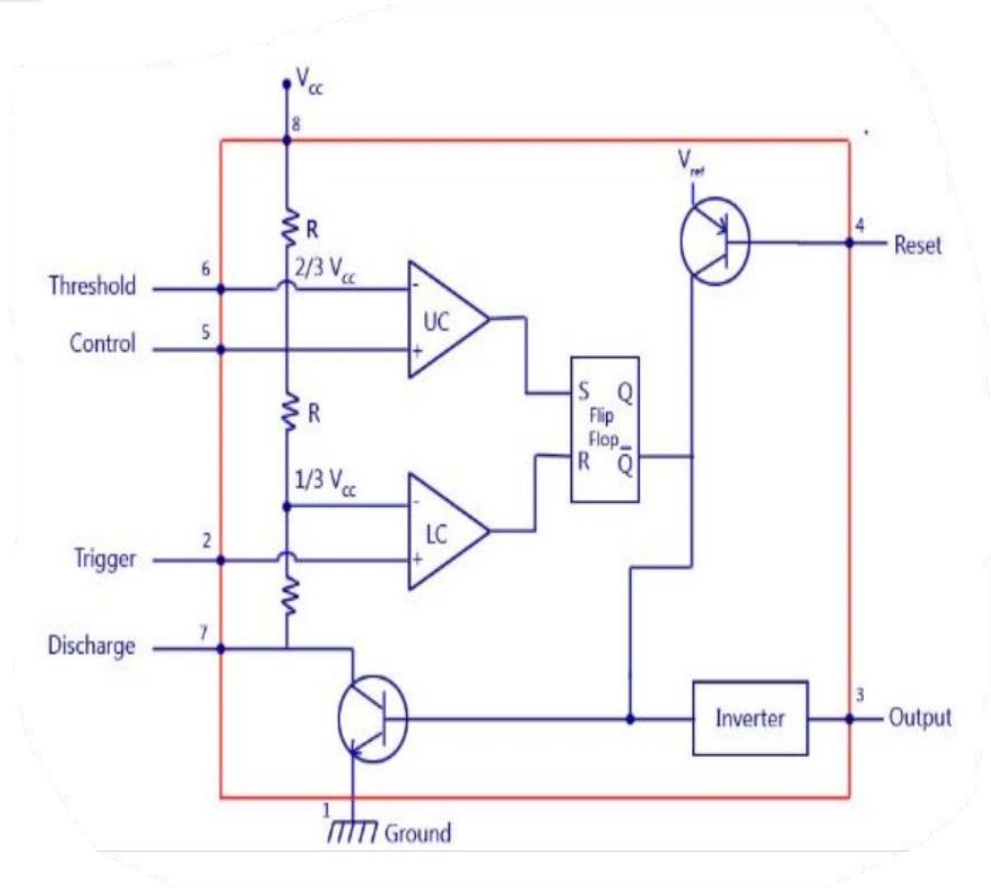

BASIC TIMING CONCEPTS

- Resistive network consists of three equal resistors and acts as a voltage divider.
- Comparator 1 compares threshold voltage with a reference voltage + $2/3$ VCC volts.
- Comparator 2 compares the trigger voltage with a reference voltage + $1/3$ VCC volts.
- Output of both the comparators is supplied to the flip-flop. Flip-flop assumes its state according to the output of the two comparators.
- The transistor is a discharge transistor of which collector is connected to pin 7. This transistor saturates or cuts-off according to the output state of the flip-flop.
- The saturated transistor provides a discharge path to a capacitor connected externally.

Applications of 555 Timers

- Monostable & Astable Multivibrators
- Waveform generators
- Burglar Alarms
- Measurement, Process & Control Circuits
- Missing pulse detectors
- Traffic light control
- Automatic Battery chargers
- Logic probes
- DC to DC Converters etc.

References:

- Digital Principles and Applications, A.P. Malvino, D. P. Leach and Saha, 7th Ed., 2011, Tata McGraw Hill
- Digital Fundamentals, Thomas L. Floyd, 11th Ed., 2015, Pearson Education Limited
- Modern Digital Electronics, R P Jain, 4th Ed., 2010, Tata McGraw Hill