

ANALYSIS AND DESIGN OF RETROFITTING FOR RCC BUILDING

by

Girish Kumar

(18SOCE2010005)

M.Tech in Structural Engineering



**SCHOOL OF CIVIL ENGINEERING
GALGOTIAS UNIVERSITY**

GREATER NOIDA

ANALYSIS AND DESIGN OF RETROFITTING FOR RCC BUILDING

by

Girish Kumar

(18SOCE2010005)

*Submitted in partial fulfilment of the requirements of the degree of
Master of Technology in Structural Engineering*

Under the guidance of

Dr. Sushil Kumar Singh



**SCHOOL OF CIVIL ENGINEERING
GALGOTIAS UNIVERSITY
GREATER NOIDA
May, 2020**

© Galgotias University, Greater Noida, 2018

All rights reserved.

To

My Parents

&

Family

CERTIFICATE

This is to certify that the project work entitled "**Analysis and design of retrofitting for RCC building**" being submitted by **Girish Kumar** to the School of Civil Engineering, Galgotias University, Greater Noida, for the award of the degree of Master of Technology is a bonafied work carried out by him under my supervision and guidance. The thesis work in my opinion has reached the requisite standard, fulfilling the requirements for the said degree.

The results contained in this report have not been submitted, in part or full, to any other university or institute for the award of any degree or diploma.

Guide

Program chair

M.Tech (Structural Engineering)

Dean

(School of Civil Engineering)

Internal Examiner External Examiner

APPROVAL SHEET

This project report entitled “**Analysis and design of retrofitting for RCC building**” by **Girish Kumar** is approved for the degree of **Master of Technology in Civil Engineering**.

Examiner

Guide

Dean

Date: _____

Place: _____

DECLARATION

I declare that this written submission represents my ideas in my own words and where others' ideas or words have been included, I have adequately cited and referenced the original sources. I also declare that I have adhered to all principles of academic honesty and integrity and have not misrepresented or fabricated or falsified any idea/data/fact/source in my submission. I understand that any violation of the above will be cause for disciplinary action by the Institute and can also evoke penal action from the sources which have thus not been properly cited or from whom proper permission has not been taken when needed.

Girish Kumar

(18SOCE2010005)

Date: _____

Place: _____

Acknowledgements

I am highly grateful to the **Dr. Suprakash Biswas** (Dean of School of Civil Engineering) for giving me proper guidance and advice and facility for the successful completion of my thesis.

It gives me a great pleasure to express my deep sense of gratitude and indebtedness to my guide **Dr. Sushil Kumar Singh** (Assoc. Professor, School Of Civil Engineering) for his valuable support and encouraging mentality throughout the project. I am highly obliged to him for providing me this opportunity to carry out the ideas and work during my project period and helping me to gain the successful completion of my Project.

I am also highly obliged to **Dr. Sushil Kumar Singh** (Assoc. Professor, School Of Civil Engineering) project co-coordinator for providing me all the facilities in all activities and for his support and valuable encouragement throughout my project.

I would also like to thank **Mr. Ghanshyam**, Lab Tech. Galgotias University for their continuous help in experimental works.

My special thanks are going to all of the faculties for encouraging me constantly to work hard in this project. I pay my respect and love to my parents and all other family members and friends for their help and encouragement throughout this course of project work.

ABSTRACT

In India multi-storied building are usually constructed due to high cost and scarcity of land .In order to utilize maximum land area builders and architects generally propose high to medium rise building plan configurations. These buildings which are constructed in seismic prone areas, are likely to be damaged during earthquake. Earthquake is a natural phenomenon which can generate the most destructive forces on the structure. Buildings should be made safe for the lives by proper design and detailing of structural member in order to have a ductile form of failure.

The concept of earthquake resistant design is that the building should be designed to resist the forces, which arises due to Design Basis Earthquake, with only minor damages and the forces, which arises due to Maximum Considered Earthquake, with some accepted structural damages but no collapse. This project report comprises of analysis and design of a RC building. This building is designed in ETABS and Retrofitting of building is carried out by RCC jacketing and FRP method.

CONTENTS

Certificate	i
Approval Sheet	ii
Declaration	iii
Abstract	iv
Contents	v
List of Figures	viii
List of Tables	ix
Abbreviation Notation and Nomenclature	x
Chapter 1 Introduction	1
General	1
Innovative approaches to retrofitting	3
Retrofit techniques	4
Objective	5
Chapter 2 Literature Review	6
General	6
R.C.C. Jacketing	7
FRP jacketing	8
Gaps and Findings	9
Chapter 3 Structural Audit	10
Introduction	10
Purpose of Structural Audit:	11
Recommended NDT Tests	13
Sample Visual Observations:	17

Chapter 4 Methodology	19
Introduction	19
Preliminary Data	19
Load Combination	20
Load Calculation	21
Chapter 5 Formulation of Problem	22
Introduction	22
Preliminary Data	23
Application of Codes and Standards	23
Load Calculation	24
Steel Details of Building	26
Chapter 6 RCC jacketing	27
Introduction	27
Propping and Supporting	28
Rehabilitation Strategies	28
Strengthening of structure:	28
Jacketing of Column	31
Reinforced concrete jacketing of columns	32
Effect of corrosion	34
Design Example	34
Column with RCC jacketing	34
Beam with RCC jacketing	38
Chapter 7 Fiber Reinforced Polymer	45
FRP Material	45
Application in Retrofitting	46

Types of FRP material	46
Advantages of FRP material	46
Disadvantages of FRP material	47
Beam Strengthening In Flexure	47
Failure Modes	48
Design Example	48
Beam with FRP jacketing	48
Beam Strengthening In Shear	53
Column Strengthening	57
Column with FRP jacketing	58
Chapter 8 Discussion and Conclusion	66
Discussion	66
Conclusion	66
References	67
Acknowledgement	68

LIST OF FIGURES

Figure 3.1 Actual Photographs of Building No.4, Labor Camp, Matunga road, Mumbai	18
Figure 5.1 3D view of building in E-tabs	25
Figure 5.2 3D view of building in E-tabs	25
Figure 6.1 RCC Beam jacketing (Dat Duthinh & Monica Starnes (2012))	30
Figure 6.2 RCC slab jacketing (Dat Duthinh & Monica Starnes (2012))	31
Figure 6.3 RCC Column jacketing (Dat Duthinh & Monica Starnes (2012))	33
Figure 6.4 Revised section of column in ‘mm’	36
Figure 6.5 Revised section of beam in ‘mm’	39
Figure 6.6 Actual site photograph of Maduban, Indian oil Nagar, Andheri (west)	44
Figure 7.1 Cross section of Beam (ACI: 440-2)	47
Figure 7.2 geometric properties of FRP shear reinforcement (ACI:440-2R)	53
Figure 7.3 Representative interaction diagrams. (ACI: 440-2R)	58
Figure 7.4 Effectively Confined core for non circular section (FIB 14)	59
Figure 7.5 Actual site photograph of Otters Club, Joggers Park, band stand, Bandra	62

LIST OF TABLES

Table 3.1 Rebound Hammer Test (IS: 1331 (Part 2): 1992)	14
Table 3.2 USPV Test (IS 13311 (Part- I) 1992)	15
Table 3.3 Half cell potential (mV) Test	17
Table 5.1 Ast Required For Beam Strengthening	26
Table 5.2 column schedule	26
Table 6.1 Ast Required For Column Strengthening	37
Table 6.2 Ast Required For Beam Strengthening	40
Table 7.1 Material Safety Factors (ACI: 440-2R)	48
Table 7.2 Beam Details	49
Table 7.3 CFRP System Properties	49
Table 7.4 CFRP Properties	54
Table 7.5 No. of wrap required for beam	56
Table 7.6 No. of Wraps Required For Column Strengthening	61
Table 7.7 Measurement sheet for FRP jacketing	63

ABBREVIATION NOTATION AND NOMENCLATURE

SCM	Supplementary cementitious
material OPC	Ordinary Portland cement
FA	Fly ash
HVFA	High volume fly ash
GGBS	Ground granulated blast furnace slag

Chapter 1

Introduction

General

A large number of existing buildings in India are severely deficient against earthquake forces and the number of such buildings is growing very rapidly. This has been highlighted in the past earthquake. To meet up the requirements of advance infra-structure new innovative materials/ technologies in civil engineering industry has started to make its way. With structures becoming old and the increasing bar for the constructed buildings the old buildings have started to show a serious need of additional repairs.

Inadequate design and construction or need structural up gradation to meet new seismic design requirements because of new design standards, deterioration due to corrosion in the steel caused by exposure to an aggressive environment and accident events such as earthquakes. Inadequate performance of this type of structures is a major concern from public safety standpoint. That is why reinforced concrete structures often have to face modification and improvement of their performance during their service life. In such circumstances there are two possible solutions: replacement or retrofitting. Full structural replacement might have determinate disadvantages such as high costs for material and labor, a stronger environmental impact and inconvenience due to interruption of the function of the structure e.g. traffic problems. When possible, it is often better to repair or upgrade the structure by retrofitting.

Retrofitting of structures like building, which includes rehabilitation, maintenance and strengthening of the structure, is not only a need in construction management in urban areas, but also a problem which arises to structural engineers in property management disciplines. Retrofitting of any existing building is a complex task and requires skill, retrofitting of RC buildings is particularly challenging due to complex behavior of the RC composite material. The behavior of the buildings during earthquake depends not only on the size of the members and amount of reinforcement, but to a great extent on the placing and detailing of the reinforcement, foundation, walls, pillars, columns and beams. For these, structures becomes statically unsafe retrofitting techniques intend to improve performance of structure, maintaining the response below acceptable thresholds, defined also as performance limit states. The structural response of inelastic buildings is measured in terms of displacements (deformations), although the accelerations (and stresses) are also important in order to avoid damages in the non-structural components and contents of structures. Performance based

design strategy is usually concerned with prevention of structural damage to estimate the deficiency resulting from all the three sources, suggest a retrofit scheme to make up for the deficiencies and demonstrate that the retrofitted structure will be able to safely resist the future earthquake forces expected during the lifetime of the structure.

Assessment of damage is essential in selecting appropriate retrofit method. To evaluate the damage, it is necessary to determine the extent, cause of damage and whether or not the cause is still active. Selection of a repair material must be based on the assessment of the damage, characteristics of material used and local circumstances. The design of buildings is primarily concerned with ensuring the components of the building, i.e. lateral force-resisting system. The problems in design can be condensed simply by providing adequate force and deformation capacity to resist the seismic demands. In this paper retrofitting of an existing building using different retrofitting techniques is presented.

Seismic retrofitting is mainly done to meet the seismic safety requirements. The planning of alterations to existing buildings differs from new planning through an important condition; the existing construction must be taken as the basis of all planning and building actions. Seismic retrofit is primarily applied to achieve public safety, with various levels of structure and material survivability determined by economic considerations. In recent years, an increased urgency has been felt to strengthen the deficient buildings, as part of active disaster management and to work out the modifications that may be made to an existing structure to improve the structural performance during an earthquake. The present guidelines are intended to provide a systematic procedure for the seismic evaluation of buildings, which can be applied consistently to a rather wide range of buildings. This document also discusses some cost effective strengthening schemes for existing older buildings. If private and public building structures get damaged, in extreme cases they can be dismantled. But in case of structures of historical importance, they can't be dismantled. And here comes the only way to save these structures- Retrofitting.

Retrofitting is defined as the process of modification of existing structures like buildings, bridges, heritage structures to make them more resistant to the seismic activity and other natural calamities. The strengthening and enhancement of the performance of deficient structural elements or the structure as a whole is referred to as retrofitting. Retrofit aims to strengthen a building to satisfy the requirements of the current codes for seismic design. The building may not be damaged or deteriorated. Retrofitting increases the service life and level of structures. Retrofitting works are done by various methods like jacketing, sealing, stitching, overlaying,

wrapping, coating, re-baring, NSM system etc. out of many natural and environmental disasters, seismic action earthquake affects the structures most. It has been seen that structures with the passing of time they lose their strength because of many reasons like seismic activity, soil failure due to ground motion etc. Then there arises problems like damaging of roof.

Innovative approaches to retrofitting

The main innovative methods of retrofitting may be grouped into the following classes:

- Stiffness reduction
- Ductility increase
- Damage controlled structures
- Composite materials

Any suitable combination of the above methods for equal mass the ‘stiffness reduction’ produces a period elongation and a consequent reduction of the seismic action and therefore of the seismic strength demand. In general it may be assumed that base isolation is a special case of the stiffness reduction approach. Although very effective, this method must be used with a pinch of salt. Too low a stiffness may result in large displacements, especially inter-story drifts, which may conflict with the functioning of the building and cause damage to non-structural components.

Therefore deformability checks are always a must. Instances in which this method may not be effective are the cases of long period structures or of stiff structures on soft soils. In the first case the advantages gained by a reasonable increase in period may be negligible; in the second case the stiffness reduction may be counterproductive by leading to an increase of spectral ordinates. An application of the ‘stiffness reduction method’ will be shown in some detail in a further section. A ‘ductility increase’ may be achieved locally by confinement of reinforced concrete flexural as well as compressed structural members. Although this method has a long history, it may now be applied easily using new materials such as fiber reinforced polymers (FRP). These materials are distinguishable by the type of fibre and the most common are denoted by CRP, GRP, ARP, indicating respectively reinforcement with carbon (C), glass (G) and aramid (A) fibres.

Retrofit techniques

There are many retrofit techniques available, depending upon the various types and conditions of structures. Therefore, the selection of the type of intervention is a complex process, and is governed by technical as well as financial and sociological considerations.

The following are some factors affecting the choice of various intervention techniques:-

- Cost versus importance of the structure.
- Available workmanship.
- Duration of work/disruption of use.
- Fulfillment of the performance goals of the owner.
- Functionally and aesthetically compatible and complementary to existing building.
- Reversibility of the intervention Level of quality control.

Objective

1. To Analysis old building and calculate its present strength by NDT.
2. To redesign that old building by RCC jacketing and FRP jacketing for deficiency of strength.
3. To Compare the RCC jacketing and FRP jacketing as economy point of view.

Chapter 2

Literature Review

General

This chapter provides an introduction to the strengthening of reinforced concrete (RC), concrete and steel members using externally bonded steel plate or fibre reinforced polymer (FRP) composites sheets and plates by reviewing the most significant investigations reported in the literature. In addition, a section is devoted to the strengthening of RC members in shear utilizing FRP plates and sheets. However, since the external plating and its application as a strengthening technique has only been made possible by the development of suitable adhesives, consideration is also given to the types of adhesive which may be used for external plate bonding and their requirements for this application.

After considering reported plate bonding studies, a brief review of surface preparation techniques applicable to FRP and concrete adherents are presented.

R.C.C. Jacketing

Wang and Smith (2014) have proposed the scheme for improving seismic performance of joint. For a strong beam weak column failing joint it has been shown that it is only necessary to retrofit the plastic hinge support region of the top and bottom column to change the failure mode as per more desirable strong column weak beam failure mode. The test result has indicated that existence of slab significantly improve the bending stiffness of beam.

Julio and Branco et al. (2003) find that RC jacketing strengthening method leads to a uniformly distributed increase in strength and stiffness of columns. The durability of the original column is also improved, in contrast to the corrosion and fire protection needs of other techniques where steel is exposed or where epoxy resins are used.

Rehman and Baluch (2002) has study a case representing a wide spectrum of events triggering structural distress in RC structures have been documented and the importance of simulation of the structures using finite element models for consideration of various repair options has been highlighted.

Thermau and Elnasha (2006) has concludes with a global assessment of the effect of repair methods on stiffness, strength and ductility. The three most important seismic response parameters, to assist researchers and practitioners in decision-making to satisfy their respective intervention objectives. The framework for the paper complies with the requirements of consequence-based Engineering.

Kevadekar and Kodag (May 2013) conclude that concept of using steel bracing is one of the advantageous concepts which can be used to strengthen structure storey drift of the Shear wall and steel braced model is within the limit as clause no. Steel bracings can be used as an alternative to the other strengthening techniques available as the total weight of structure changes significantly. Shear wall has more storey shear as compare to steel bracing but there are 10 to15% differences in lateral displacement between shear wall and steel bracing. Shear wall and steel bracing increases the level of safety since the demand curve intersect near the elastic domain. Capacity of the steel braced structure is more as compare to the shear wall structure. Steel bracing has more margin of safety against collapse as compare with shear wall.

FRP jacketing

Lakade et al. (2015) suggested that some of the beams failed in flexural capacity. The number of beams failed in First floor is considerable and it goes on reducing in upper floors. No beam fails in shear, it means that the members are having enough shear of beams. Column fails in flexure as well as shear as the demand capacity ratio obtained as less than one. Hence no retrofitting is required for columns also based on the above observations, the need of reducing the deficiency of beams in flexural capacity was identified and the FRP jacketing scheme was suggested only for beams, failing in flexure.

Bhardwaj and Belali (2015) in this paper we presented a comprehensive study, its steps, procedure and the use of retrofitting in various fields. The combination of engineering, machines and years of experience make this possible to develop the technology of retrofitting. At present day, retrofitting has a very lucrative market in the developed and as well as developing countries. It provides a number of ways to improve the damaged structure and allows expanding the lifespan of a structure, increasing its functioning and safety.

Ghobarah and said (2001) from the results of the experimental program, effective methods for rehabilitating existing deficient beam-column joints are developed. A comparison between the performance of original specimens and rehabilitated ones shows that the GFRP jacket was capable of increasing the shear resistance of the joint and enhancing the performance of the connection from a ductility point of view.

Bhavar et al. (2013) Strengthening of building considered in the report is an attempt to increase the life and to sustain the unwanted disturbances like, earthquakes floods etc. The building though was proposed to have been constructed as six storied building and was designed as per requirements, but was constructed only up to two storeys; it should have worked or served for a period more than the designed life span.

Gaps and Findings

1. Most of the Research papers only referring about the FRP jacketing method for RCC building.
2. So we are designing the structure with both the method. And we will compare the advantages and disadvantages of the method and suggest the suitable method for Old RCC Buildings.

Chapter 3

Structural Audit

Introduction

Structural Audit is an important tool for knowing the real status of the old buildings. The Audit should highlight & investigate all the risk areas, critical areas and whether the bldg. needs immediate attention. It should also cover the structural analysis of the existing frame and pinpoint the weak structural areas for static, wind & earthquake loads. If the bldg. has changed the user, from residential to commercial or industrial, this should bring out the impact of such a change.

It gives step by step guidelines for carrying out Structural Audit of old buildings also provided a detailed format to collect data from the field.

The details regarding the various non-destructive tests and other tests to be carried out are also given and Includes photographs of structural defects & rectification procedure.

Purpose of Structural Audit:

- To save Life & Property.
- To know the health of your building and to project the expected future life.
- Highlight the critical areas that need to be attended with immediate effect.
- To proactively assist the residents and the society to understand the seriousness of the
- Problems and the urgency required to attend the same.
- To comply with Municipal or any other statutory requirements.

Step 1:

It is imperative that we must have Architectural and Structural plans of the buildings. It will be helpful if we have detailed structural calculations including assumptions for the structural design.

The assumptions can also include the allowable live loads; whether the bldg. is designed for residential, commercial, light industry or heavy industry and whether any future provision for adding new floors is considered? What type of Earthquake loads is considered? Which I.S.Code requirements have been met?

Step 2:

If the Architectural plans and Structural plans are not available, the same can be prepared by any Engineer by measuring the size of the building & locating the position of the columns, beams and size of all such structural elements.

Step 3:

A detailed inspection of the building can reveal the following:

- Any settlements in the foundations.
- Visual cracks in columns, beams and slabs
- Concrete disintegration and exposed steel reinforcements – photographs can be helpful.
- Slight tapping with hammer can reveal deterioration in concrete.
- Extent of corrosion in reinforcement.
- Status of Balconies – sagging, deflection, cracks?
- Status of Architectural features viz. chhajjas, fins, canopies etc.
- Cracks in walls indicating swelling in R.C.C. members or distress or deflection or corrosion.
- Leakages from terrace & Toilet blocks.
- Leakages & dampness in walls resulting into cracks and corrosion.
- Changes carried out affecting structure.
- Toilet blocks - Added or changes made?
- Change of user – from Residential to Commercial to Industrial? Change of Partition Walls?
- Status of lift and lift machine room – Type of Maintenance Contract, renewal of license.
- Status of electrical wiring from meter room to all the flats. Substation status. Any explosion in the meter room, substation?
- Status of overhead & underground water tanks - capacity. Leakages, cracks &

frequency of cleaning, status of pumps.

- Plinth protection in the compound including status of drainage, water pipes & pumps. How much the Ground was flooded during recent monsoons?
- How much was spent for repairs?
- Building plans available? When approved? Occupation Certificate available? Structural Plans available? Structural Stability Certificate available? Structural Calculations available?
- Last Structural Audit prepared?

Step 4:

It is important that various tests are carried out in the old building. This will give an idea about the extent of corrosion, distress and loss of strength in concrete & steel.

Recommended NDT Tests

The following NDT tests are required to be carried out on structural elements. However, it is important that the testing scheme is prepared based on preliminary survey of the building/structure:-

- A. Core tests** to determine the estimated equivalent in situ compressive strength & to establish correlation between Rebound hammer test & in situ strength of concrete.
- B. Rebound Hammer test** to estimate the in situ compressive strength of cover concrete.
- C. USPV test** to assess the integrity of concrete.
- D. Carbonation test** to assess the depth of carbonated concrete.
- E. Cover test** to assess the cover provided to RCC structural members.
- F. Half Cell potentiometer test** to determine the probability of active corrosion.

A. Core Test:

- The reinforcement is detected at planned location with the help of Rebar locator called Profometer to avoid cutting of reinforcement.
- The Core cutting equipment is fixed at the planned location & core is extracted.

- The Cores are transported to the laboratory & visual observations of cores are recorded for interpretation purpose. Reinforcement bars, if encountered, are cut off.
- The Cores are removed from water cut to the required L/D ratio of 2, wherever possible, exactly perpendicular to the longitudinal axis.
- Both the ends are prepared by grinding up to the tolerance limit as specified by Clause 4:8 of BS 188: Part 120: 1983 for flatness & parallelism.

B. Rebound Hammer Test:

The test is performed as per guidelines given by IS: 1331 (Part 2): 1992 & BS 1881: Part 202: 1986 to estimate the in situ strength of concrete based on the correlation established between in-situ strength at the particular location & rebound numbers.

- The plaster is removed at test locations.
- For testing, smooth, clean, dry surface without any defect like Honeycombing cracks and hollow sound is selected.
- The area of approx. 300 mm x 300 mm is rubbed with carborandum stone to remove loosely adhering scales, or remains of plaster mortar, if any.
- In this area 12 points at approximate 30 mm apart are selected in grids.
- By holding the rebound hammer at right angles to surface of the concrete member, 12 readings are taken at selected points. Of these readings, abnormally high & abnormally low results are eliminated & average of the balance readings is worked out.
- Taking into consideration the factors influencing hardness of the concrete surface like moisture condition of the surface, carbonation, test location within the member, direction of test etc. corrected rebound number is worked out.
- The compressive strength of concrete against each rebound number is obtained from graph prepared on correlation established between rebound numbers at core test locations & equivalent cube strength values.
- The statistical analysis is carried out for this set of values of compressive strengths obtained by above method.

Table 3.1 Rebound Hammer Test (IS: 1331 (Part 2): 1992)

Average Rebound	Quality of Concrete
>40	Very good
30-40	Good
20-30	Fair
<20	Poor and / or delaminated
0	Very poor and/or delaminated

C. USPV test:

- The plaster is removed at test locations wherever required.
- For testing, smooth, clean, dry surface without any defect like honey combing, cracks, and hollow sound is selected.
- The area of approx. 300 mm x 300 mm is rubbed with carbonation stone to remove loosely adhering scales, or remains of plaster mortar, if any.
- Two points are marked on opposite faces of the concrete members. (At exactly opposite locations for direct transmission of ultrasonic pulses).
- Grease is applied as a coupling medium to ensure proper contact of the transducers with concrete surface so that ultrasonic pulse is transmitted through the medium without much disturbance.
- Now both the transducers are held at correct test locations by applying constant pressure & ultrasonic pulses are transmitted through the concrete.
- The machine displays the time taken to travel the known path in microseconds.
- The velocity is calculated from the reading obtained against each known path.
- Following velocity criterion for concrete quality grading is given by IS 13311 (Part- I): 1992.

Table 3.2 USPV Test (IS 13311 (Part- I) 1992)

Pulse Velocity	Concrete Quality	Concrete Grade
> 4.0 km/s	Very good to excellent	I
3.5-4.0 km/s	Good to very good, slightly porosity may exist	II
3.0-3.5 km/s	Satisfactory but loss of integrity is suspected	III
<3.0 km/s	Poor and loss of integrity exist	IV

D. Carbonation Test Procedure:

The powder of concrete is obtained by drilling inside into concrete at selected location. Then the collected powder is made moist & then phenolphthalein indicator is dropped on it to check any color change. If the color changes to pink, indicates that concrete is not affected by carbonation & if no color change is observed, indicates concrete is affected by carbonation.

E. Cover Meter Test Procedure:

The instrument used is PROFOMETER - 4, Rebar Locator Model S, manufactured by M/s. PROCEQ SA, Switzerland, which is able to perform following functions:-

- To locate the bar accurately.
- To assess the clear cover to the bar.
- To calculate bar diameter of the selected bar.

The instrument works on magnetic principle & has limitations of spacing between bars to identify the bars individually.

The limitation of rebar locator instrument to identify bars, its diameter is that depth of rebar from concrete surface should be less than to 70 mm depth & spacing of bars should be more than 150 mm.

F. Half-cell Potentiometer Test Procedure:

The half-cell potentiometer consists of a rigid tube, which contains a copper rod immersed in a copper sulphate solution. This is connected to a voltmeter and another live wire connection comes through voltmeter to connect it to rebar. To start the experiment firstly the live wire is connected to a rebar of the test specimen and the rigid tube is put on the surface of concrete and the reading of voltmeter is taken. Reading gives the potential difference between the electrodes. From the value of the potential difference, corrosion status inside the concrete can be predicted.

The possibility of active corrosion is found out according to guideline below:

Table 3.3 Half cell potential (mV) Test

Sr. no.	Potential mV(mili volts)	Corrosion in the steel
1	< - 0.200	No corrosion of Steel
2	- 0.200 to - 0.350	Uncertain corrosion Activity
3	> - 0.350	Corrosion Occurring in the steel

Sample Visual Observations:

- Chajjas are severely affected by corrosion.
- Severe corrosion cracks are developed in columns.
- Top level slab is severely affected by corrosion, cover of concrete has spalled down and steel is exposed.
- Front side Chajja throughout the length of structure is severely affected by corrosion.
- Top level beams are affected by corrosion.
Almost 100% columns in the top floor have corrosion related distress.



Figure 3.1 Actual Photographs of Building No.4, Labour Camp, Matunga road, Mumbai

Chapter 4

Methodology

Introduction

In this chapter, Building modeling is done on the E-tabs and Analysis of building is carried out. After analysis Design of Reinforcement is done. Consider that building is too old and age is more than 60 years, so due to leakage and environmental action building is not in good condition. Structural Auditing is carried on the building. In auditing report it is found that slab and footing is found Safe but due to corrosion of reinforcement beam and column got crack and its give lower strength. To increase the strength of building different Retrofitting method is applied on it.

Preliminary Data

Building is located in Mumbai, it's a residential building G+4 structure, and building is 60 years old. Other essential data given below

- Type of structure = RCC Building
- Zone = III
- Layout = as shown in fig.
- Number of stories = G+4
- Ground storey height = 3 m.
- Floor to floor height = 3 m
- Parapet wall =150 mm thick including plaster
- Wall thickness =230 mm thick including plaster
- Total depth of the slab =150 mm
- Size of all columns = 230 × 450 mm
- Size of all beams = 230 × 400 mm
- Density of RCC concrete = 25kN/m³
- Unit weight of brick masonry is =20kN/m³
- Weight of floor finish (FF) = 1kN/m²

- Live load on floor = 2kN/m^2

Load Combination

- Comb. 1 – 1.5 (DL+LL)
- Comb. 2 – 1.2 (DL+LL+EL)
- Comb. 3 – 1.2 (DL+LL-EL)
- Comb. 4 – 1.5 (DL+EL)
- Comb. 5 – 1.5(DL-EL)
- Comb. 6 – $-0.9\text{DL}+1.5\text{EL}$
- Comb. 7 – $-0.9\text{DL}-1.5\text{EL}$

Application of Codes and Standards

1. IS 15988:2013
2. IS 456:2000
3. IS 13311 (Part- I): 1992
4. IS: 1331 (Part 2): 1992

Load Calculation

The building is considered to be situated in zone III & it is a public building, Dead Load Data:—

- Roof load
 - Self weight of the slab = $25 \times 0.15 = 3.75\text{kN/m}^2$
 - Weight of floor finish = 1kN/m^2
 - Weight of terrace water proofing = 1.5kN/m^2
 - Total slab weight on roof = 6.25kN/m^2
- Floor load
 - Self weight of the slab = $25 \times 0.15 = 3.75\text{kN/m}^2$
 - Weight of floor finish = 1kN/m^2
 - Total slab weight on floor = 4.75kn/m^2

- Wall load
 - Parapet weight of wall = $20 \times 0.15 = 3\text{kN/m}$
 - Weight of wall = $20 \times 0.23 = 12.65\text{kN/m}$

- Live Load Data
 - Live load on roof = 1kN/m^2
 - Live load on floor = 2kN/m^2

Chapter 5

Formulation of Problem

Introduction

In this chapter, Building modeling is done on the E-tabs and Analysis of building is carried out. After analysis Design of Reinforcement is done. Consider that building is too old and age is more than 60 years, so due to leakage and environmental action building is not in good condition. Structural Auditing is carried on the building. In auditing report it is found that slab and footing is found Safe but due to corrosion of reinforcement beam and column got crack and its give lower strength. To increase the strength of building different Retrofitting method is applied on it.

Preliminary Data

Building is located in Mumbai, it's a residential building G+4 structure, and building is 60 years old. Other essential data given below

- Type of structure = RCC Building
- Zone = III
- Layout = as shown in fig.
- Number of stories = G+4
- Ground storey height = 3 m.
- Floor to floor height = 3 m
- Parapet wall = 150 mm thick including plaster
- Wall thickness = 230 mm thick including plaster
- Total depth of the slab = 150 mm
- Size of all columns = 230×450 mm
- Size of all beams = 230×400 mm
- Density of RCC concrete = 25 kN/m^3
- Unit weight of brick masonry is = 20 kN/m^3
- Weight of floor finish (FF) = 1 kN/m^2
- Live load on floor = 2 kN/m^2
- Type of soil = hard soil

Application of Codes and Standards

1. IS 15988:2013
2. IS 456:2000
3. IS 13311 (Part- I): 1992
4. IS: 1331 (Part 2): 1992

Load Calculation

The building is considered to be situated in zone III & it is a public building, dead Load data

• Roof load

- Self weight of the slab $= 25 \times 0.15 = 3.75\text{kN/m}$
- Weight of floor finish $= 1\text{kN/ m}^2$
- Weight of terrace water proofing $= 1.5\text{kN/ m}^2$
- Total slab weight on roof $= 6.25\text{kN/m}^2$

• Floor load

- Self weight of the slab $= 25 \times 0.15 = 3.75\text{kN/m}^2$
- Weight of floor finish $= 1\text{kN/ m}^2$
- Total slab weight on floor $= 4.75\text{kN/m}^2$

• Wall load

- Parapet weight of wall $= 20 \times 0.15 = 3\text{kN/m}$
- Weight of wall $= 20 \times 0.23 = 12.65\text{kN/m}$

• Live Load Data

- Live load on roof $= 1\text{kN/m}^2$
- Live load on floor $= 2\text{kN/m}^2$

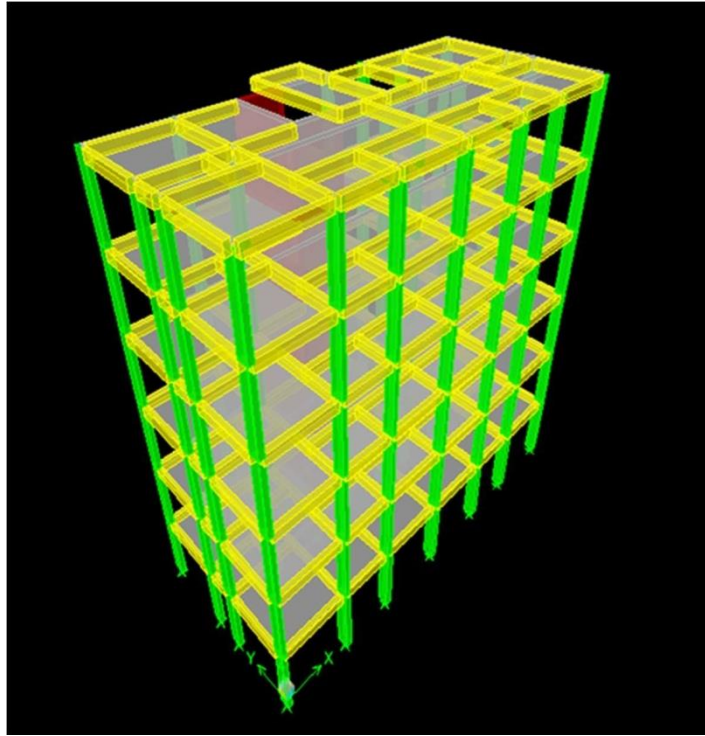

Figure 5.1 3D view of building in E-tabs

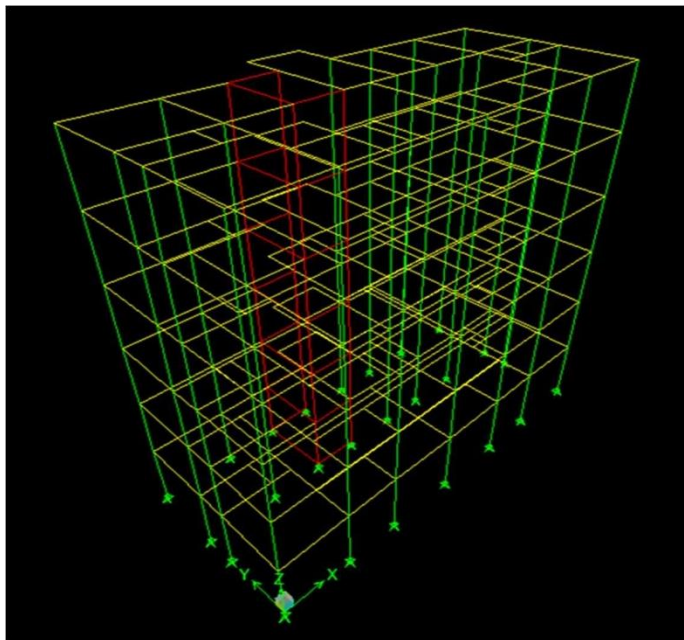

Figure 5.2 3D view of building in E-tabs

Steel Details of Building

Table 5.1 Ast Required For Beam Strengthening

FLOOR NO.	BEAM NO	WIDTH	DEPTH	TOP STEEL	BOTTOM STEEL
GROUND FLOOR	B1to B39	230 mm	450 mm	2-12 ϕ	3-16 ϕ
FIRST FLOOR	B1to B39	230 mm	450 mm	2-12 ϕ	3-16 ϕ
SECOND FLOOR	B1to B39	230 mm	450 mm	2-12 ϕ	3-16 ϕ
THIRD FLOOR	B1to B39	230 mm	450 mm	2-12 ϕ	3-16 ϕ
FOURTH FLOOR	B1to B39	230 mm	450 mm	2-12 ϕ	3-16 ϕ

Table 5.2 column schedule

Column No.	Ground Floor	1st floor	2nd floor	3rd floor	4th floor
C1 to C20, C25	C230X450	C230X450	C230X450	C230X450	C230X450
	5-16 ϕ	5-16 ϕ	5-16 ϕ	5-16 ϕ	5-16 ϕ
C26 C21 C22 C23 C24	C230X450	C300X500	C300X500	C300X500	C300X500
	7-16 ϕ	7-16 ϕ	7-16 ϕ	7-16 ϕ	7-16 ϕ

Chapter 6

RCC jacketing

Introduction

Reinforced concrete jacketing increases the member size significantly. This has the advantages of increase the member stiffness and is useful where deformation is to be controlled. If columns in the building are found to be slender, RC jacketing provides a better solution for avoiding buckling problems. Design for the strengthening repair work is based on the composite action of the old and new work. Strain compatibility calculations may have to be carried out carefully giving due accounts to factors such as creep. As the jacket is to behave compositely with the parent member, the new jacket can take the additional loads only with the increase in the stress and strain in the old one.

The problem arises if:

- Old concrete has reached limiting strain and is not likely to sustain any more significant strain.
- Old concrete is weak and porous and started deteriorating due to weathering action and corrosion reinforcement.

The question arises then as to whether the composite action should be abandoned and the new RC jacket designed to carry the entire load. It perhaps best to design the strengthening in this manner, but detailing must be right to ensure transfer of load to the new jacket, if the old concrete fails. It is however necessary to ensure perfect bond also between the old and the new concrete by providing shear keys and effective bond coat with the use of epoxy or polymer modified cement slurry giving strength not less than that of new concrete. Plate bonding and RC jacketing are the common methods of strengthening RCC structures. The cost difference between the two methods based on actual needs and the suitability of each method respect to the structural architectural and other details of the buildings

Propping and Supporting

Problem arises in deciding on propping and supporting the structure to give relief in stress and strain in some of the existing weak members being strengthened. Mere vertical props sitting on some beam & slabs may not be enough. Diagonal bracing to transmit the loads to the adjacent columns should also be considered.

Rehabilitation Strategies

A number of options are available for giving a relief to a distressed structure, which could cover any of the following:—

- Reducing of dead/live loads
- Repair/ Strengthening of Columns. Beams and slabs
- Improving the compressive strength of concrete;
- Attending to cracks and joints;
- Improving the masonry structure to be able to resist earthquake forces;
- Providing protective cover against the aggressive deteriorating chemicals.

Strengthening of structure:—

These form the basic structural elements on most of the building structural systems, which are deteriorated and require attention to improve the load carrying capacity. Their structural Modification or strengthening would give the required relief to the structural and enhance its performance as under:

A. Columns: The strengthening of column may be required for the following

- Capacity: The load carrying capacity of the column can be enhanced by section enlargement. Different types of arrangement for section enlargement are shown in fig.
- Ductility/ confinement: The ductility of the column can be enhanced by providing additional ties, steel plate bonding, and fibre wrap.

- Joints: The joints play crucial for resisting earthquake forces. The joints can be strengthening by enlargement, jacketing by steel collar and fibre wrap.

B. Beams: The strengthening of Beam may be required for the following

- Flexural Strength: The flexural strength of the beam can be enhanced by Section enlargement in compression.
- Additional reinforcement in the tension. Caution shall be exercised to ensure that section is not over reinforced while providing additional reinforcement to compensate loss of reinforcement due to corrosion etc.
- The provisioning for enhancement tensile strength if being undertaken. This should be accompanied with corresponding increase in compression as well. Due to such an increase flexural capacities required to ensure ductile behavior during earthquake shall also considered for provision.
- MS plate bonding.
- High Strength Fibre Wrap Technique (w/o section enlargement.)

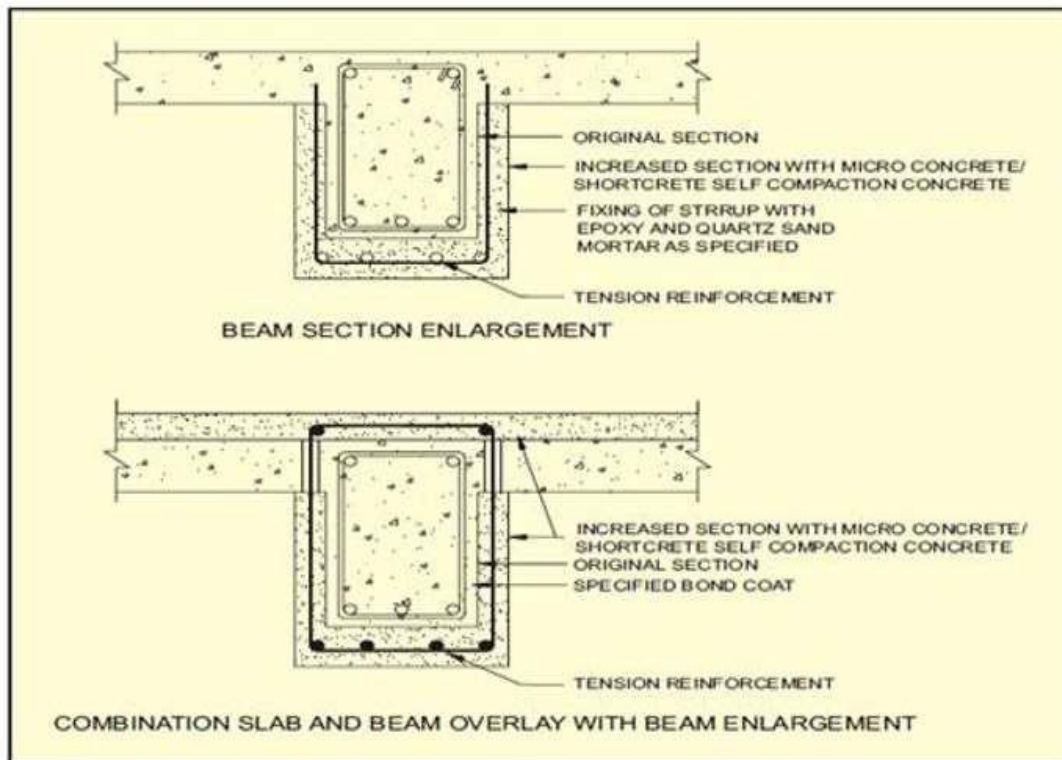

Figure 6.1 RCC Beam jacking (Dat Duthinh & Monica Starnes (2001))

C. Shear Strength: The shear strength of the beam can be enhanced by any of the following :—

- Section enlargement.
- Shear ties anchored in compression zone of beam.
- Post tension strap around the section.
- Diagonally anchored bolts (the holes are drilled perpendicular to the possible shear cracks).
- MS Steel plate bonding.
- Fibre wraps.

D. Slabs: The performance of the slab can be improved by providing overlays (in case of negative moment deficiency) or underlay (in case of positive moment deficiency).

The addition of overlay/underlay will also increase the stiffness of the slabs and control the excessive deflections problems. The slabs are generally safe in shear and as such no need is likely to occur for shear strengthening except flat slabs near column capital.

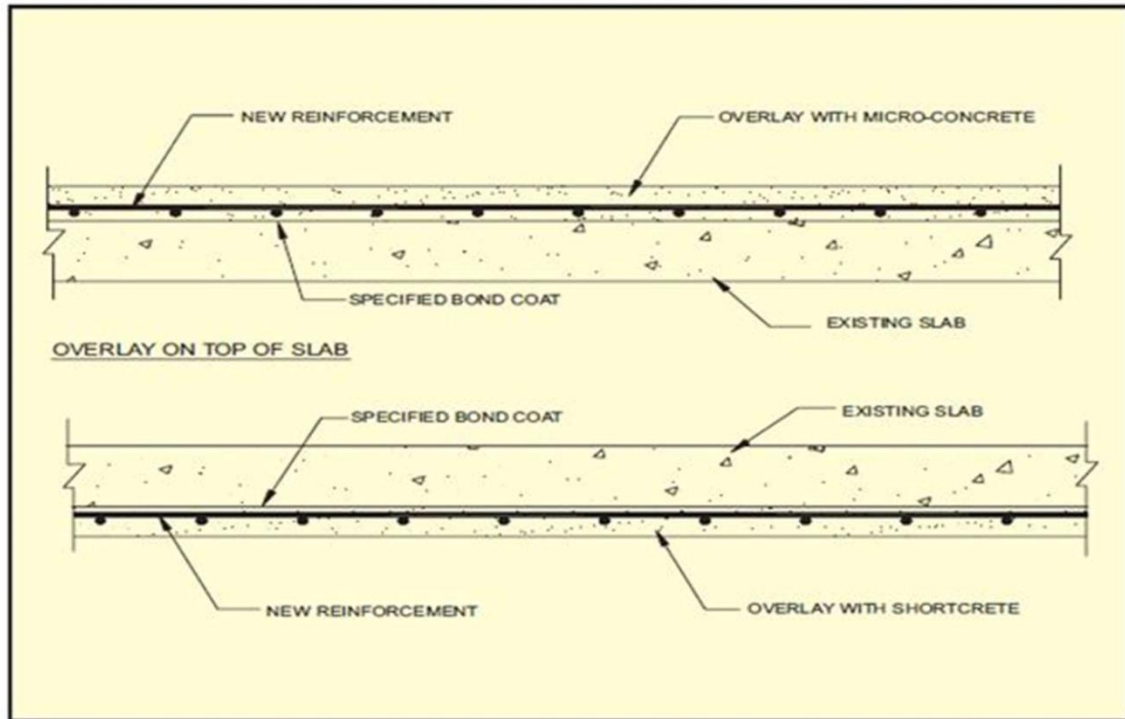

Figure 6.2 RCC slab jacketing (Dat Duthinh & Monica Starnes (2001)

Structural repairs to Columns/beams/slabs due to corrosion of reinforcement are most frequented in the normal practice. The step by step sequence of repairs stage have been given for structural repairs to RCC columns, beams and slabs under different conditions of deterioration.

Jacketing of Column

Jacketing should be applied in cases of heavy damaged columns or in the case of insufficient column strength. This is really strengthening procedure although, but it can be used for repairing. Jacketing can be performed by adding reinforcement, steel profiles or steel encasement.

Reinforced concrete jacketing, depending on the space around the column, can be done by

- One sided jacketing

- Two sided jacketing
- Three sided jacketing
- Four sided of the column.

Strengthening of reinforced concrete columns is needed when:-

- The load carried by the column is increased due to either increasing the number of floors or due to mistakes in the design.
- The compressive strength of the concrete or the percent and type of reinforcement are not according to the codes' requirements.
- The inclination of the column is more than the allowable.
- The settlement in the foundation is more than the allowable.

6.3.1 Reinforced concrete jacketing of columns

Reinforced concrete jacketing improves column flexural strength and ductility. Closely spaced transverse reinforcement provided in the jacket improves the shear strength and ductility of the column.

The procedure for reinforced concrete jacketing is as follows:-

- The seismic demand on the columns, in terms of axial load P and moment M is obtained.
- The column size and section details are estimated for P and M as determined above.
- The existing column size and amount of reinforcement is deducted to obtain the amount of concrete and steel to be provided in the jacket.
- The extra size of column cross-section and reinforcement is provided in the jacket.
- Increase the amount of concrete and steel actually to be provided as follows to account for losses.
- If the transfer of axial load to new longitudinal steel is not critical then friction present at the interface shall be relied on for the shear transfer, which shall be enhanced by roughening the old surface.
- Dowels which are epoxy grouted and bent into 90° hook shall also be employed to improve the anchorage of new concrete jacket.

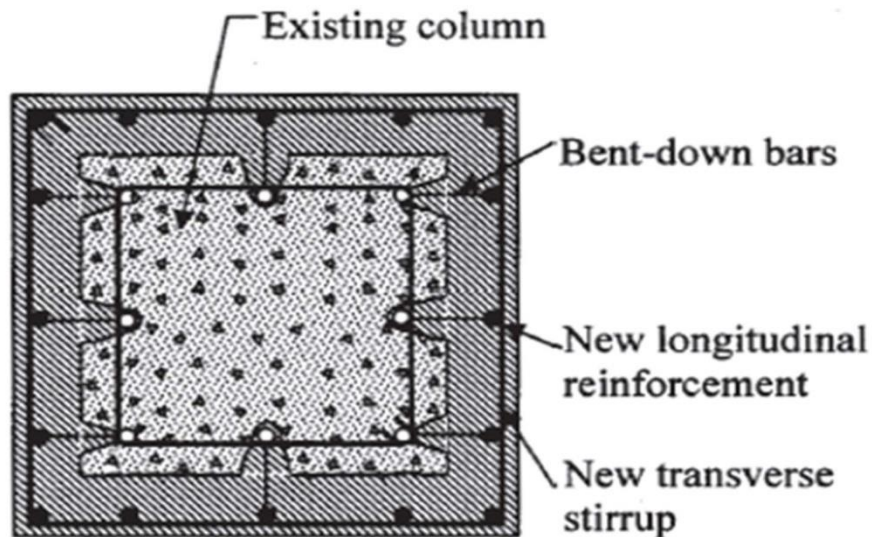

Figure 6.3 RCC Column jacketing (Dat Duthinh & Monica Starnes (2001))

The minimum specifications for jacketing columns are:-

- Strength of the new materials shall be equal or greater than those of the existing column. Concrete strength shall be at least 5 MPa greater than the strength of the existing concrete.
- For columns where extra longitudinal reinforcement is not required, a minimum of 12ϕ bars in the four corners and ties of $8\phi @ 100$ c/c should be provided with 135° bends and 10ϕ leg lengths.
- Minimum jacket thickness shall be 100 mm.
- Lateral support to all the longitudinal bars shall be provided by ties with an included angle of not more than 135° .
- Minimum diameter of ties shall be 8 mm and not less than one-third of the longitudinal bar diameter.
- Vertical spacing of ties shall not exceed 200 mm, whereas the spacing close to the joints within a length of $\frac{1}{4}$ of the clear height shall not exceed 100 mm. preferably, the spacing of ties shall not exceed the thickness of the jacket or 200 mm whichever is less.

Effect of corrosion

The corrosion of steel rebar in an RC column/ beam reduces the cross section steel area and creates local discontinuities of the steel surface. The tensile capacity of the steel is reduced in proportion directly to the loss of steel area. Moreover, the loss of the steel surface causes a loss of bond between the steel and the surrounded concrete. All of the actions contribute the loss of stiffness and ductility of the column, thus reduce the ultimate strength of the column. It's studied that corrosion up to 1.5% does not affect, but 4.5% corrosion level may reduce the ultimate load capacity to 12%. In general, the corrosion level can be determined from the % of weight loss.

Design Example

- **Column with RCC jacketing**

Height of Column= 3 m, Width (b) = 230 mm, Depth (D) = 450 mm,

Ultimate Axial Load (P) = 1212 KN, Ultimate Moment (M) = 25 kN.m, Concrete grade by NDT=12 N/mm², d'= effective cover = 50 mm, Reinforcement provided: 8-16Ø = 1608 mm²

Solution:-

$$P_u = 0.4 \times f_{ck} \times A_c + 0.67 \times f_y \times A_s$$

$$P_u = 0.4 \times 12 \times ((230 \times 450) - (828)) + 0.67 \times 415 \times 0$$

$$P_u = 412.06 \text{ KN} < 605 \text{ KN} \dots\dots\dots \text{not safe}$$

$$\text{Load deficiency} = 605 - 412.06 = 193$$

KN Reinforcement required

$$d'/D = 50 / 450 = 0.111$$

$$P/f_{ck} bD = 193 \times 10^3 / (12 \times 230 \times 450) = 1.55$$

$$M/ f_{ck} bD^2 = 25 \times 10^6 / (12 \times 230 \times 450^2) = 0.155$$

Using the P – M interaction curve for rectangular

section $P / f_{ck} = 0.02$

$\% p = 0.02 \times 25 = 0.5\%$

Area of steel required = $0.5 \% \times 230 \times 450 = 517.5 \text{ mm}^2$

But as per IS 15988:2013, Area of steel for jacketing = $(4/3) A_s$

$= (4/3) \times 517 = 690 \text{ mm}^2$

But minimum steel for jacketing section = 0.8% of C/S Area of jacketed section

$= 828 \text{ mm}^2$

Hence provide 4-16 ϕ for jacketing section.

Thickness of the jacket section to be provided

100mm

Revised jacketed section of the column will be 330 mm wide x 650 mm deep

Design of lateral Ties

Dia of bar = $\frac{1}{4}$ of ϕ of largest longitudinal bar

$= \frac{1}{4} \times 16 = 4\text{mm} \dots \text{take}$

Spacing of bar

1. Least lateral dimension = 230mm
2. 200mm
3. $16 \times \phi$ of smallest longitudinal reinforcement = $16 \times 16 = 256\text{mm}$

Provide 8mm ϕ @200mm C/C

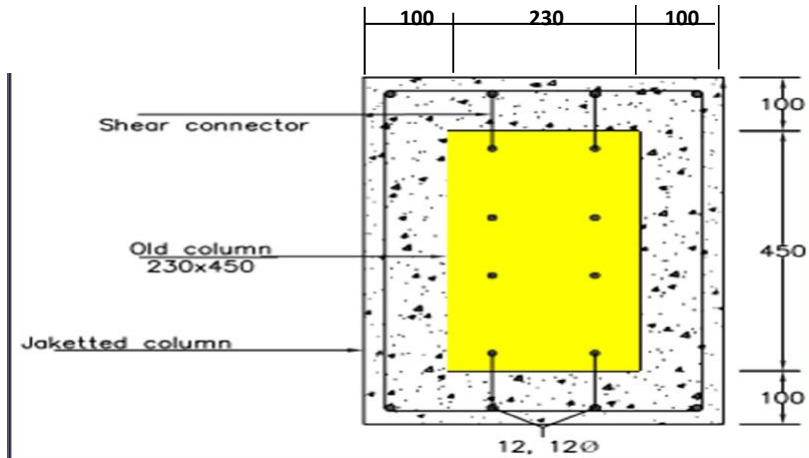

Figure 6.4 Revised section of column in 'mm'

Table 6.1 Ast Required For Column Strengthening

Sr. no	floor level	Column no.	Area of steel Required (mm ²)	Provided Area of steel (mm ²)	No of bar
1	Ground Floor	C1 to C20, C25	690 mm ²	828 mm ²	4 -16 φ
		C26 C21 C22 C23 C24	650 mm ²	1468 mm ²	4 -16 φ
2	First Floor	C1 to C20, C25	690 mm ²	828 mm ²	4 -16 φ
		C26 C21 C22 C23 C24	650 mm ²	1468 mm ²	4 -16 φ
3	second Floor	C1 to C20, C25	690 mm ²	828 mm ²	4 -16 φ
		C26 C21 C22 C23 C24	650 mm ²	1468 mm ²	4 -16 φ

4	Third Floor	C1 to C20, C25	690 mm ²	828 mm ²	4 -16 φ
		C26 C21 C22 C23 C24	650 mm ²	1468 mm ²	4 -16 φ
5	Fourth Floor	C1 to C20, C25	650 mm ²	828 mm ²	4 -16 φ
		C1 to C20, C25	650 mm ²	1468 mm ²	4 -16 φ

- **Beam with RCC jacketing**

Due to corrosion of reinforcement moment carrying capacity and share strength of beam is reduces. To increase the flexural strength of beam extra steel is required. Following is the data given. Calculate extra steel for required moment. (Assume existing Reinforcements is zero due corrosion for analysis purpose)

Data:-

$$Mu = 49 \text{ kNm}, A_{st} \text{ provided} = 418 \text{ mm}^2 = 2 - 16 \phi$$

$$f_{ck} \text{ by NDT} = 12 \text{ N/mm}^2,$$

$$f_y = 415 \text{ N/mm}^2,$$

$$b = 230 \text{ mm},$$

$$d = 360 \text{ mm},$$

$$D = 400 \text{ mm},$$

RCC jacketed section Extra $A_{st} = 2, 16 \phi$,

$$b = 430 \text{ mm}, d = 460 \text{ mm}, D = 500 \text{ mm}$$

Solution:

$$X_u = \frac{0.87 f_y A_{st}}{0.36 f_{ck} b} = \frac{0.87 \times 415 \times 418}{0.36 \times 12 \times 430} = 81.24 \text{ mm}$$

$$M.R. = 0.138 f_{ck} b d^2 = 0.138 \times 12 \times 430 \times 460^2 = 147.12 \times 10^6 \text{ N.mm}$$

$$M.U = 0.87 f_y A_{st} (d - 0.42 X_u) = 0.87 \times 415 \times 418 (460 - 0.42 \times 460)$$

$$= 64.27 \text{ kNm} > 49 \text{ kNm} \dots\dots\dots \text{Safe}$$

Design of shear reinforcement

Step: - 1

$$V_u = 18\text{kN}$$

$$A_{st} = 2,16\phi = 402.12\text{mm}^2$$

Step: - 2

$$P_t \% = \frac{100A_{st}}{bxd} = \frac{100 \times 418}{430 \times 460} = 0.211\%$$

$$\zeta_c = 0.31 \text{ N/mm}^2 \dots\dots\dots \text{FROM TABLE}$$

$$\text{Shear capacity of section} = 0.31 \times b d = 0.31 \times 430 \times 460 = 61.31\text{kN}$$

But $61.31 \text{ KN} > 18 \text{ KN}$ Safe

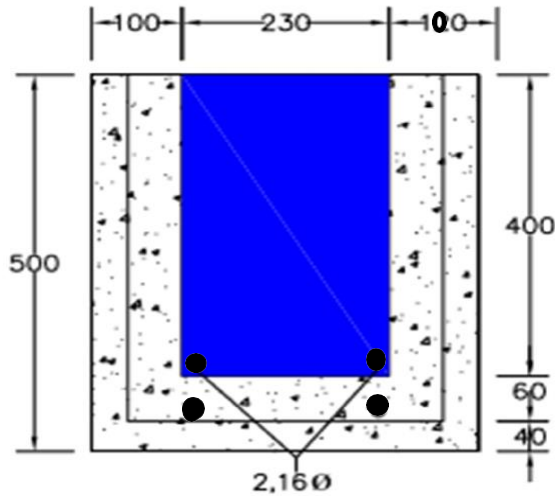

Revised Section Of Beam

Figure 6.5 Revised section of beam in 'mm'

Table 6.2 Ast Required For Beam Strengthening

Sr. No	Floor	Beam No.	M.R. Required (kN.m)	Ast Provided	M.R. Provided (kN.m)
1	First Floor	B1 to B39	49 KNm	2 -16 ϕ	64 KNm
2	Second Floor	B1 to B39	49 KNm	2 -16 ϕ	64 KNm
3	Third Floor	B1 to B39	49 KNm	2 -16 ϕ	64 KNm
4	Forth Floor	B1 to B39	49 KNm	2 -16 ϕ	64 KNm

Table 6.3 Measurement sheet for RCC jacketing

Sr. No.	Item	Unit	Rate	Quantity	Amount
1	Excavation for foundations, substructures, basements, tanks, sumps, walls, chambers, manholes, trenches, poles, pits & general building works in all types of soils, vegetable earth, soft murum, running sand, shingle, turf clay, loam, peat, ash, shale, slag, chalk, garbage, muddy/ marshy/ slushy soil, marine clay, reclaimed land etc. for depths/lifts up to 1.5M measured from the ground level, including dressing/ trimming the sides, leveling and ramming of bottoms, manual dewatering, removing rank vegetation.	cum	500	290	145000
2	Demolishing brick work in lime or cement mortar including plaster, paint, etc. manually/ by mechanical means including stacking of serviceable material and disposal of unserviceable material within 50 meters lead as per direction of Engineer-in-charge	cum	310	18	5580

3	<p>JACKETING FOR COLUMN & BEAM</p> <p>Jacketing the existing column or beam of size as shown in the drawing by removing the concrete cover to reinforcement, by chipping or other suitable means to expose the reinforcement of existing column or beam in order to make available the same for binding the extra reinforcement as shown in the drawing and also removal of rust, scales of the reinforcement in order to provide and apply approved make of epoxy resin to get proper bond with newly laid M25 grade Micro concrete. The aforesaid concrete shall be laid by the sides of the existing column with uniform thickness of 100 mm or as specified, for jacketing purposes thereby increasing the sectional dimensions by 150 mm or as specified (excluding finishing) at any height with requisite shuttering, centering, scaffolding, propping, repairing the existing surface as specified and also removal of debris, curing etc.</p>	cum	12330	99	1220670
---	---	-----	-------	----	----------------

4	<p>Complete REINFORCEMENT</p> <p>Providing and fixing in position steel bars reinforcement of various diameters for R.C.C. pile, pile caps, footings, raft, retaining wall, shear wall, lift wall, foundations, slabs, beams, columns, canopies, staircases, newels, chajjas, lintels, pardies, coping, fins, arches, etc. as per detailed designs, drawings and bar bending schedules, including straightening, cutting, bending, hooking the bars, binding with wires or tack welding, supporting as required etc. all complete at all levels.</p>	MT	69196	10	691960
5	<p>POLYMER MODIFIED MORTAR FOR SLAB</p> <p>Providing and applying Polymer modified cement mortar of average thickness 15mm using Polymer in one or more layers in proportion 1:5:15 of Polymer Cement Quartz Sand as manufacturer's specifications in specific layers, curing the surface after 72 hours of application with wet gunny bags etc and by finishing the surface with 12mm thick (1:3) Cement sand plaster.</p>	Per sqft	180	1500	270000
	Total amount				23,33,210



Figure 6.6 Actual site photograph of Maduban, Indian oil Nagar, Andheri (west)

Chapter 7

Fibre Reinforced Polymer

FRP Material

Fibre reinforced polymer (FRP) composites consist of high strength fibres embedded in a matrix of polymer resin. Fibres typically used in FRP are glass, carbon and aramid. These fibres are all linear elastic up to failure, with no significant yielding compared to steel. The primary functions of the matrix in a composite are to transfer stress between the fibres, to provide a barrier against the environment and to protect the surface of the fibres from mechanical abrasion. The mechanical properties of composites are dependent on the fibre properties, matrix properties, fibre-matrix bond properties, and fibre amount and fibre orientation. A composite with all fibres in one direction is designated as unidirectional. If the fibres are woven, or oriented in many directions, the composite is bi- or multidirectional. Since it is mainly the fibres that provide stiffness and strength composites are often anisotropic with high stiffness in the fibre direction.

In strengthening applications, unidirectional composites are predominantly used, the approximate stiffness and strength of a unidirectional CFRP with a 65% volume fraction of carbon fibre is given. As a comparison the corresponding properties for steel are also given. Adhesives are used to attach the composites to other surfaces such as concrete. The most common adhesives are acrylics, epoxies and urethanes. Epoxies provide high bond strength with high temperature resistance, whereas acrylics provide moderate temperature resistance with good strength and rapid curing. Several considerations are involved in applying adhesives effectively. Careful surface preparation such as removing the cement paste, grinding the surface by using a disc sander, removing the dust generated by surface grinding using an air blower and careful curing are critical to bond performance.

Application in Retrofitting

For structural applications, FRP is mainly used in two areas. The first area involves the use of FRP bars instead of steel reinforcing bars or pre-stressing strands in concrete structures. The other application, which is the focus of this thesis, is to strengthen structurally deficient structural members with external application of FRP. Retrofitting with adhesive bonded FRP has been established around the world as an effective method applicable to many types of concrete structural elements such as columns, beams, slabs and walls. FRP plates can be bonded to reinforced concrete structural elements using various techniques such as external bonding, wrapping and near surface mounting. Retrofitting with externally bonded FRP has been shown to be applicable to many types of RC structural elements. FRP plates or sheets may be glued to the tension side of a structural member to provide flexural strength or glued to the web side of a beam to provide shear strength. FRP sheets can also be wrapped around a beam to provide shear strength and be wrapped around a column to provide confinement and thus increase the strength and ductility. Near surface mounting consists of sawing a longitudinal groove in a concrete member, applying a bonding material in the groove and inserting an FRP bar or strip.

Types of FRP Material

- Carbon
- Aramid
- Glass

Advantages of FRP material

- Corrosion Resistance
- Light Weight
- Ease of Installation
- Less Finishing
- Less Maintenance
- High tensile strength
- Storage & Transportation is easy

Disadvantages of FRP material

- Temperature & moisture effect
- Lack of Design Code
- Lack of Awareness
- Skill supervision is required

Beam Strengthening In Flexure

In flexural strengthening applications FRP plates or sheets are bonded to the tensile surfaces of reinforced concrete beams. It is assumed that FRPs are perfectly linear-elastic materials. Thus, failure of an FRP-strengthened section in flexure can be due to FRP rupture or to concrete crushing. The ultimate flexural strength for both of these failure modes can be calculated using a similar methodology as that used for steel-reinforced sections.

The design Values for the FRP material safety factor suggested in Table7.1

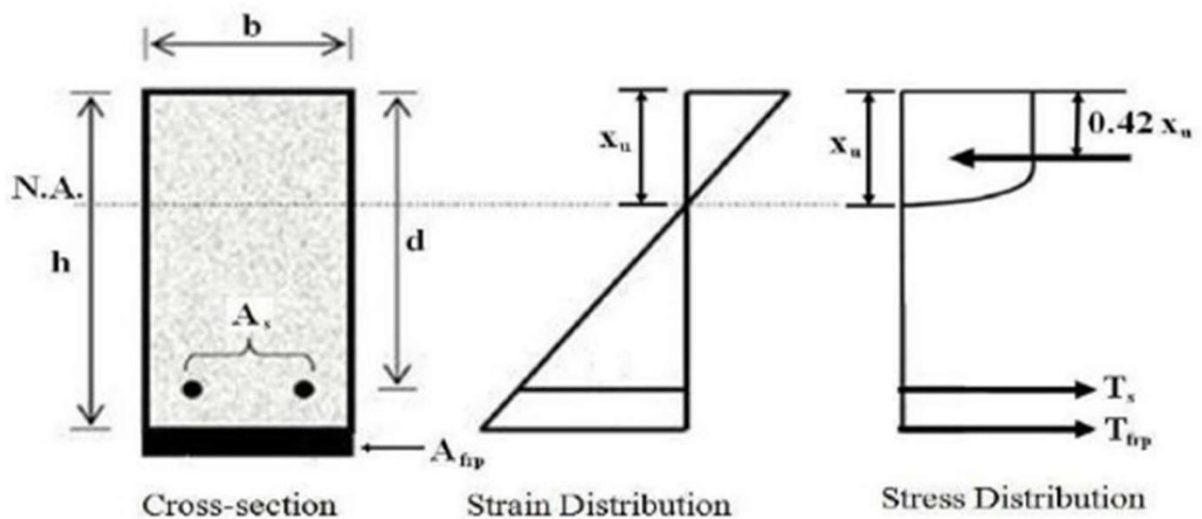

Figure 7.1 Cross section of Beam (ACI: 440-2)

Table 7.1 Material Safety Factors (ACI: 440-2R)

FRP type	Application type A(1)	Application type A(11)
CFRP	1.20	1.35
AFRP	1.25	1.45
Aramid	1.3	1.5

7.3.1 Failure Modes

There are four potential flexural failure modes for externally-strengthened reinforced concrete flexural members:-

- Concrete crushing before yielding of the reinforcing steel;
- Steel yielding followed by concrete crushing;
- Steel yielding followed by FRP rupture; and
- Debonding of the FRP reinforcement at the FRP/concrete interface.

It is not always clear at the outset of a design or analysis which of the above failure modes will govern. Thus, an assumption must be made and the failure mode checked.

Design Example

- **Beam with FRP jacketing**

Due to corrosion of reinforcement moment carrying capacity and share strength of beam is reduces. To increase the flexural strength of beam FRP wrap is required. Following is the data given. Calculate layer of wrap for required moment. (Assume existing Reinforcements is zero due corrosion for analysis purpose.

Table 7.2 Beam Details

C/S of Beam	230x400
Top Steel	2-8T
Bottom steel	2-16T

Stirrups	8T@150C/C
d (Effective Depth)	360mm
Moment	49 kN.m
Vu (Shear force)	18 kN.
Grade of concrete (f_{ck})	25 N/mm ²
Grade of Steel reinforcement (f_y)	415 N/mm ²

Table 7.3 CFRP System Properties

Thickness Per Ply (tf)	1.02mm.
Ultimate Tensile Strength (f_{fu}^*)	621 N/mm ²
Rupture Strain (ϵ_{fu}^*)	0.015mm/mm.
Modulus Of Elasticity Of CFRP Laminate (E_f)	37,000N/mm
Width of FRP sheet (wf)	100mm

Step 1:- Calculate the FRP system design material properties

Design ultimate tensile strength of FRP

$$f_{fu} = C_E \times f_{fu}^*$$

$$f_{fu} = 0.95 \times 621 = 589.95 \text{ MPa}$$

Design ruptures strain of FRP reinforcement

$$\epsilon_{fu} = C_E \times \epsilon_{fu}^*$$

$$\epsilon_{fu} = 0.95 \times 0.015 = 0.01425 \text{ mm/mm}$$

Step 2:- Preliminary calculations

Modulus of elasticity of concrete

$$i) E_c = 5000\sqrt{f_c'} = 5000\sqrt{12} = 17320.50 \text{ MPa}$$

ii) Properties of the externally bonded FRP reinforcement:

Thickness of FRP = 1.02 mm, No. of FRP = 1 No, Width of FRP = 100 mm

$$A_f = n t_f w_f = 1 \times 1.02 \times 100 = 102\text{mm}^2$$

Step 3:- Determine the existing state of strain on the soffit

$$M_{DL} = 49 \text{ kN.m}, d_f = 400\text{mm}, k = 0.334$$

Assume, $I_{cr} = 7.266 \times 10^8$from SP16 table No.87

Strain level in concrete substrate at time of FRP installation

$$\epsilon_{bi} = \{M_{DL} (d_f - kd)\} / (I_{cr} \times E_c) = 0.000553$$

Step 4:- Determine the design strain of the FRP system

Debonding strain of externally bonded FRP reinforcement,

$$\begin{aligned} \epsilon_{ad} &= 0.41 \{ \sqrt{(f_{ck} / 2E_f t_f)} \} \\ &= 0.41 \{ \sqrt{(12 / 2 \times 37000 \times 1.02)} \} \end{aligned}$$

$$\epsilon_{fd} = 0.0073 <= 0.9 \times (0.0142) = 0.0128 \dots \dots \text{OK}$$

Step 5:- Estimate c, the depth to the neutral axis

The value of the c is adjusted after checking equilibrium.

$$C = 0.2 \times d = 0.2 \times 360$$

$$C = 72 \text{ mm}$$

Step 6:- Determine the effective level of strain in the FRP reinforcement

Effective strain level in FRP reinforcement attained at failure,

$$\epsilon_{fe} = (0.0035 \{(d_f - c) / c\}) - \epsilon_{bi} <= \epsilon_{fd}$$

$$\epsilon_{fe} = 0.0152 > 0.0042478 \dots \text{not ok}$$

$$\text{Revise effective strain } \epsilon_{fe} = \epsilon_{fd} = 0.0073$$

$$\text{Strain level in concrete, } \epsilon_c = (\epsilon_{fe} + \epsilon_{bi}) [C / (d_f - C)]$$

$$\epsilon_c = 0.0017$$

Step 7:- Calculate the strain in the existing reinforcing steel

Strain level in steel reinforcement,

$$\epsilon_s = (\epsilon_{fe} + \epsilon_{bi}) [(d - C) / (d_f - C)] \epsilon_s = 0.0069$$

Step 8:- Calculate the stress level in the reinforcing steel and FRP

Stress in Steel

$$f_s = E_s \epsilon_s \leq f_y$$

$$f_s = 1390.5 > 415 \dots \text{not ok}$$

$$f_s = f_y = 415.00 \text{ MPa}$$

Stress in FRP

$$f_{fe} = E_f \epsilon_{fe}$$

$$f_{fu} = 270.50 \text{ MPa}$$

Step 9:- calculate internal forces resultant and check equilibrium

$$\epsilon_c = 0.002$$

$$\beta_1 = (4\epsilon'_c - \epsilon_c) / (6\epsilon'_c - 2\epsilon_c) = 0.734$$

$$\alpha_1 = (3\epsilon'_c \epsilon_c - \epsilon_c^2) / (3\beta_1 \epsilon'_c^2)$$

$$= 0.840$$

$$C = (A_s f_s + A_f f_{fe}) / (\alpha_1 f'_c \beta_1 b)$$

$$= 16.19 < 72.4 \text{ mm, take } C = 72.4 \text{ mm}$$

Step 10:- Calculate flexural strength components

$$\text{Steel contribution to bending (Mns)} = A_s f_s \left(d - \left[\frac{b_1 \times \epsilon_c}{2} \right] \right)$$

$$M_{ns} = 55.95 \text{ kN-m}$$

$$\text{FRP contribution to bending (Mnf)} = A_f f_{fe} \left(d_f - \left[\frac{b_1 \times \epsilon_c}{2} \right] \right)$$

$$M_{nf} = 10.30 \text{ kN-m}$$

Step 11:- Calculate design flexural strength of the section

The design flexural strength is calculated as, $\phi M_n = \phi [M_{ns} + \psi_f M_{nf}]$

A strength reduction factor of $\phi = 0.90$

$$\phi M_n = 0.9(55.95 + 0.85(10.30)) = 58.23$$

$$\phi M_n = 58.23 \text{ kN-m} > M_u 49 \text{ kN-m} \dots\dots\dots \text{Safe}$$

Hence the proposed FRP strengthening scheme satisfies the design requirements with suitable safety margin.

- **Beam Strengthening In Shear**

FRP materials can be applied to the side faces (webs) of reinforced concrete beams to provide external shear reinforcement, as shown in Fig. 7-2

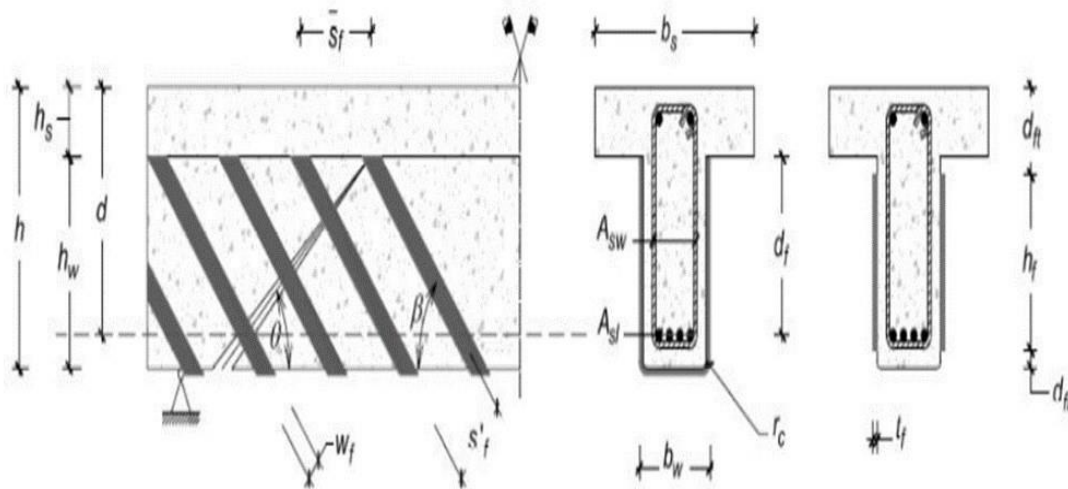

Figure 7.2 geometric properties of FRP shear reinforcement (ACI: 440-2R)

In this technique, fibres can be aligned at any angle to the longitudinal axis of the beam. The FRPs can be applied to the side faces only or in the form of U-wraps which are continuous underneath the beam. U wraps have the added advantage of improving the anchorage of flexural external FRP reinforcements when placed over the flexural sheets or strips. Furthermore, FRP shear reinforcement can be applied as continuous sheets or in strips of finite width externally bonded FRP shear reinforcement acts in a manner similar to internal steel stirrups, by bridging shear cracks to increase the shear capacity of the concrete. Since the length over which FRP stirrups can be anchored is limited by the height of the beam, the quality of the existing concrete is of utmost importance. To avoid possible failure of the FRP sheets due to stress concentrations at the corners of the beam, corners should be rounded to a minimum radius of 15 mm.

Table 7.4 CFRP Properties

Thickness Per Ply (tf)	1.02mm.
Ultimate Tensile Strength (ffu*)	621 N/mm2.
Rupture Strain (Efu*)	0.015mm/mm.

Modulus Of Elasticity Of CFRP Laminate (E _f)	37,000N/mm ² .
Width of FRP sheet (w _f)	100mm

Step 1—calculate the FRP system design material properties

Design ultimate tensile strength of FRP

$$f_{fu} = C_E \times f_{fu}^* = 0.95 \times 621 = 589.95 \text{ MPa}$$

Design ruptures strain of FRP reinforcement

$$\epsilon_{fu} = C_E \times \epsilon_{fu}^* = 0.95 \times 0.015 = 0.01425 \text{ mm/mm}$$

Step 2—calculate the effective strain level in the FRP shear reinforcement

Active Bond Length,

$$L_e = \frac{23300}{(n \times t_f \times E_f)^{0.58}} = \frac{23300}{(n \times t_f \times E_f)^{0.58}} = 34.63 \text{ mm}$$

Modification Factor for concrete strength

$$K_1 = (f_{cr}/27)^{2/3} = (25/27)^{2/3} = 0.94$$

Modification Factor for wrapping scheme

$$K_2 = ((d_{fv} - L_e)/d_{fv}) = ((237 - 34.63)/237) = 0.853$$

Bond-dependent coefficient for shear

$$K_v = \frac{k_1 \times k_2 \times L_e}{11900 \times \epsilon_{fu}} = \frac{0.94 \times 0.853 \times 34.63}{11900 \times 0.014} = 0.166 < 0.75$$

Effective strain level in FRP reinforcement attained at failure

$$\epsilon_{fe} = K_v \times \epsilon_{fu} = 0.166 \times 0.0142 = 0.0023 < 0.004$$

Step 3— Cal. Contribution of the FRP r/f to the shear strength

Area of FRP shear reinforcement with spacing s,

$$A_{fv} = 2n t_f w_f = 2 \times 1 \times 0.165 \times 254 = 83.82 \text{ mm}^2$$

Effective Stress in FRP Shear Reinforcement

$$f_{fe} = \epsilon_{fe} \times \epsilon_f = 0.0023 \times 227.6 = 0.523 \text{ KN/ mm}^2$$

Nominal shear strength provided by FRP stirrups

$$\begin{aligned} V_f &= \frac{A_{fv} \times f_{fe} \times (\sin \alpha + \cos \alpha) d_f v}{S_f} = \frac{83.82 \times 0.523 \times 1 \times 237}{304.8} \\ &= 34.08 \text{ KN} \end{aligned}$$

Step 4— Total Shear Strength of Section

$$\Phi V_n = \phi (V_c + V_s + \Psi_f V_f) = 0.75 \times (66.65 + 0 + 0.85 \times 34.08)$$

$$= 71.71 \text{ KN} > 18 \text{ kN} \quad \dots\dots\dots \text{Safe}$$

Hence provide 1 layer of CFRP jacket

Table 7.5 No. of wrap required for beam

Sr. No	Floor	Beam No.	M.R. Required. (kN.m)	No of Wraps Required	M.R. Provided (kN.m)
1	First Floor	B1 to B39	49 KNm	1	58.23 KNm
2	Second Floor	B1 to B39	47 KNm	1	58.23 KNm
3	Third Floor	B14 to B39	49KNm	1	58.23 KNm
4	Fourth Floor	B1to B39	37 KNm	1	58.23 KNm

- **Column Strengthening**

FRP systems can be used to increase the axial compression strength of a concrete member by providing confinement with an FRP jacket wrapping with an FRP jacket can also provide strength enhancement for a member subjected to combined axial compression and flexure. Confining a concrete member is accomplished by orienting the fibres transverse to the longitudinal axis of the member. In this orientation, the transverse or hoop fibres are similar to Conventional spiral or tie reinforcing steel. Any contribution of longitudinally aligned fibres to the axial compression strength of a concrete member should be neglected.

Increased ductility of a section results from the ability to develop greater compressive strains in the concrete before compressive failure. The FRP jacket can also serve to delay buckling of longitudinal steel reinforcement in compression and to clamp lap splices of longitudinal steel reinforcement. For seismic applications, FRP jackets

should be designed to provide a confining stress sufficient to develop concrete compression strains associated with the displacement demands.

The following limitations apply for members subjected to combined axial compression and bending :-

- The effective strain in the FRP jacket should be limited to the value to ensure the shear integrity of the confined concrete.

$$\epsilon_{fe} = 0.004 \leq \kappa \epsilon_{fu}$$

- The strength enhancement can only be considered when the applied ultimate axial force and bending moment, P_u and M_u , fall above the line connecting the origin and the balanced point in the P-M diagram for the unconfined member This limitation stems from the fact that strength enhancement is only of significance for members in which compression failure is the controlling mode.

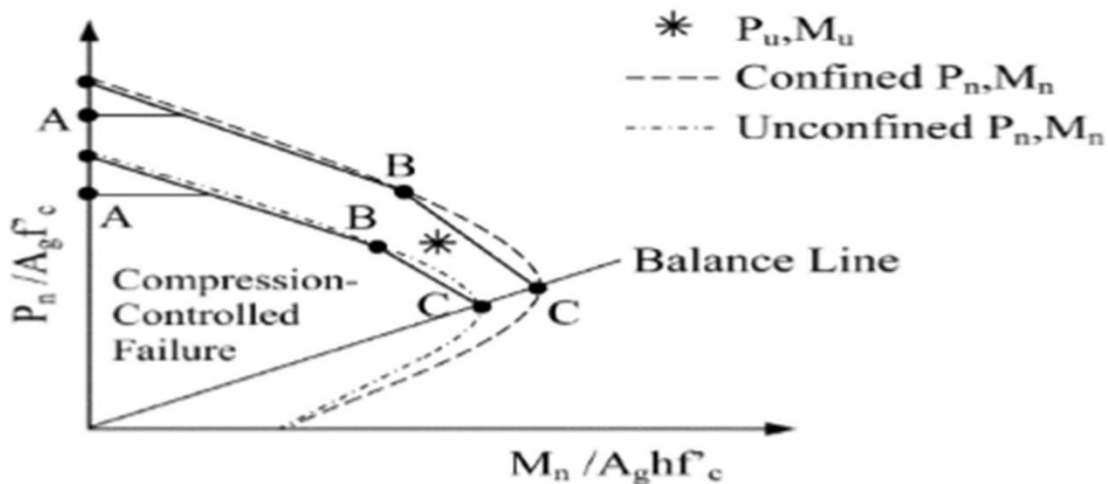

Figure 7.3 Representative interaction diagrams. (ACI: 440-2R)

7.6.1 Column with FRP jacketing

Due to corrosion of reinforcement Axial Force carrying capacity of column is reduces. To increase the axial strength of column extra confinement is required. Following is the data given. Calculate no of FRP layer for required axial force.

Data:-

$b = 230 \text{ mm}$, $d = 450 \text{ mm}$,

$f_{ck} \text{ provided} = 12 \text{ Mpa}$, $f_{ck} \text{ required} = 25 \text{ Mpa}$,

$P_t \% \text{ provided} = 0.02\%$,

Area of concrete = 103500 mm^2 ,

$P_u = 1212 \text{ KN}$, M25 Manufacture Data –

Ultimate strain in carbon fiber (ϵ_f) = 1.5%

Elastic modulus of carbon fiber (E_f) = 137000 N/mm^2

Effective fiber thickness (t) = 0.33 mm

No of Wrap (n) = 2 No.

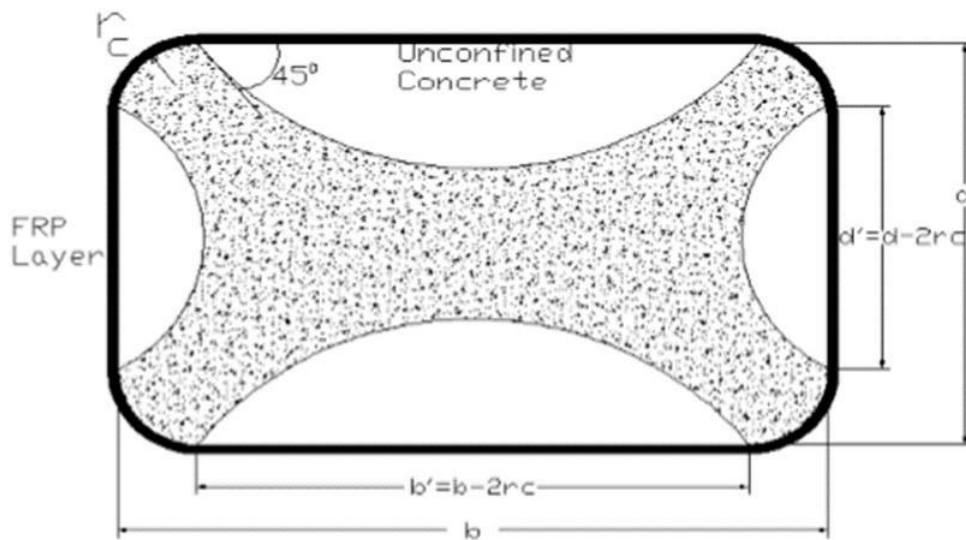

Figure 7.4 Effectively Confined core for non circular section (FIB 14)

Solution:

$$P_u = 0.4 \times f_{ck} \times A_c + 0.67 \times f_y \times A_{st}$$

$$= 0.4 \times 12 \times ((230 \times 450) - (1608)) + 0.67 \times 250 \times 0$$

$$P_u = 489.06 \text{ KN} < 1212 \text{ KN} \dots\dots\dots \text{not safe}$$

$$\text{Load deficiency} = 1212 - 489.06 = 794.9 \text{ KN}$$

Step No. -1

Total Plan Area of Unconfined concrete is obtained as per Fib 14 equation 6.28 is

$$\text{given as, } b' = b - 2 \times rc = 230 - 2 \times 25 = 180 \text{ mm}$$

$$d' = d - 2 \times rc = 450 - 2 \times 25 = 400 \text{ mm}$$

$$A_u = \frac{b'^2 + d'^2}{3} = 64133.33 \text{ mm}^2$$

Step No. -2

The confinement effectiveness coefficient k_e considering ratio $(A_c - A_u)/A_c$ as per Fib 14 equation 6.29 is given as,

$$K_e = 1 - \frac{b'^2 + d'^2}{3f_c (1 - q_{cg})} = 1 - \frac{A_{EU}}{3f_g (1 - q_{cg})} = 0.367$$

Step No. -3

The Lateral confining pressures induced by the FRP wrapping as per Fib 14 equation 6.30 is given as

Along direction b,

$$K_{confb} = \rho_b k_e E_f \quad \text{Along direction d, } K_{confd} = \rho_d k_e E_f$$

$$\text{Where, } \rho_b = \frac{2xntxf}{b} \quad \text{and} \quad \rho_d = \frac{2xntxf}{d}$$

$$\rho_b = 0.0057 \quad \text{and} \quad \rho_d = 0.0029$$

$$K_{confb} = 288.09, \quad K_{confd} = 147.31$$

Step No. -4

Effective confining pressure,

along direction b —

$$F_{lb} = \frac{K_{confb} \times s_f}{2K_e}$$

$$= 5.89 \text{ N/mm}^2$$

Along direction d —

$$f_{ld} = \frac{K_{confd} s f}{2 K_e} = 3.01 \text{ N/mm}^2$$

Taking min value,

$$F_1 = 3.014 \text{ N/mm}^2$$

Step No.-5

Maximum confining pressure as per Fib equation 6.5 is given as,

$$F_{cc} = f_c \left\{ (2.254 \sqrt{1 + 7.94 \frac{f_1}{f_c}}) - \left(\frac{2f_1}{f_c} - 1.254 \right) \right\}$$

Hence provide 2 layer of CFRP jacket.

Table 7.6 No of Wraps Required For Column Strengthening

Sr. No.	floor level	Column no.	fck by NDT (N/mm²)	fck Req. (N/mm²)	No. Of Wraps Req.	Confining Pressure (N/mm²)
1	First Floor	C1 to C20, C25	12	25	2	25.73
		C26 C21 C22 C23 C24	12	25	2	29.36
2	Second Floor	C1 to C20 C25	12	25	2	25.73
		C26 C21 C22 C23 C24	12	25	2	29.36
3	Third Floor	C1 to C20 C25	12	25	2	25.73
		C26 C21 C22 C23 C24	12	25	2	28.69
4	Forth Floor	C1 to C20 C25	12	25	2	25.12
		C26 C21 C22 C23 C24	12	25	2	26.44



Figure 7.5 Actual site photograph of Otters Club, Joggers Park, band stand, Bandra

Table 7.7 Measurement sheet for FRP jacketing

Sr. No.	Item	Unit	Rate	Qty	Amount
1	Providing and fixing in vertical position telescopic M.S. prop under deflected beam/lintel/slab/chajjas by using teak wood battens of size 1000 x 80 x 80 for packing between prop plate and the beam/lintel/slab/chajjas bottom surface as per the directions of engineer-in-charge.	Per no	2038	20	40760
2	Excavation for foundations, substructures, basements, tanks, sumps, walls, chambers, manholes, trenches, poles, pits & general building works in all types of soils, vegetable earth, soft murum, running sand, shingle, turf clay, loam, peat, ash, shale, slag, chalk, garbage, muddy/ marshy/ slushy soil, marine clay, reclaimed land etc. for depths/lifts up to 1.5M measured from the ground level, including dressing/trimming the sides, leveling and ramming of bottoms, manual dewatering, removing rank vegetation, backfilling in layers not more than 200mm thickness, watering, consolidating, compacting to achieve not less than 97% Modified Proctor density conforming to relevant IS, stacking the selected material in measurable heaps for future use within owners space or disposing within an initial lead of 150m as directed, loading,	cum	500	290	145000

	unloading, leveling excluding shoring, strutting etc. complete as directed by Engineer- in charge. Note: 1) The rate includes the handling/supporting the existing utilities such as cables, drains, pipes, water mains etc.				
--	--	--	--	--	--

3	Demolishing brick work in lime or cement mortar including plaster, paint, etc. manually/ by mechanical means including stacking of serviceable material and disposal of unserviceable material within 50 meters lead as per direction of Engineer-in-charge	cum	309	18	5562
4	Chipping /removing loose concrete up to reinforcement bars, without damaging the reinforcement, removing all the loose materials and to make all the exposed surfaces free from oil, dust and all impurities etc complete.	Per Sqft	15	7882	118230

5	<p>Removing corrosion of steel reinforcement by mechanical means like wire brushing, chipping to remove loose rust and then applying rust removal solution by using brush application, leaving the surface for at least 15 to 30 minutes, then removing loose materials by scrubbing or with brush and applying polymer bond to the old concrete surface before applying Polymer mortar</p>	Per Sqft	45	7882	354690
6	<p>Plastering Providing and applying 20 mm thick external sand faced cement plaster up to 10m from ground level and at all locations in cement mortar proportion specified below in two coats for masonry (except stone masonry) and concrete surfaces including providing water proofing compound to the first coat of plaster as per manufacturers specification, racking out joints, hacking of concrete surface, finishing, curing, scaffolding, etc. complete as directed By Engineer In Charge. In cement mortar 1:3</p>	Per Sqft	38	8720	331360
7	Carbon FRP for column & beam	Per Sqft	320	3980	1273600

8	Plastering Providing and applying 20 mm thick external sand faced cement plaster up to 10m from ground level and at all locations in cement mortar proportion specified below in two coats for masonry (except stone masonry) and concrete surfaces including providing water proofing compound to the first coat of plaster as per manufacturers specification, racking out joints, hacking of concrete surface, finishing, curing, scaffolding, etc complete as directed By Engineer In Charge. In cement mortar 1:3	Per Sqft	38	8720	331360
	TOTAL				26,00,562

Chapter 8

Discussion and Conclusion

Discussion

The purpose of this project was to assess the analysis of an existing RC structure and to provide for retrofit in case the members fail. Consider building is 60 years old, G+4 R.C.C. Structure. Structural Audit is done on the building. In audit Slabs and footings are Safe, but beams and columns are unsafe. The plan and reinforcement details of the building were provided. Analyzed the building in E-tabs software, Present Building Strength is calculated, it is found that building is unsafe, for that Extra moment jacketing is design by various method.

Conclusion

- It is advisable to monitor the building health periodically by taking a professional opinion. Non-destructive testing should be carried out if buildings found deteriorated and damaged over time.
- R.C.C. retrofitting technique is significant improvement in Moment resisting capacity, shear strength capacity in Beam and Axial load carrying capacity in column, But dead load is increased and carpet area is reduces. Total Cost of project by R.C.C. jacketing is Rs.23,33,210.

FRP jacketing gives better advantages than RCC jacket Easy to implement; dead load is negligible, higher confinement, faster construction. Total Cost of project by FRP jacketing is Rs.26,00,562.

REFERENCES

1. Wang, DY, Wang, ZY & Smith, (2014) ' Experimental study on the seismic performance of full- scale interior RC beam-column joints retrofitted with FRP composite, vol. I, Southern Cross University, Lismore, Australia.
2. E S Ju´lio1, F Branco and V D Silva (2003) Structural rehabilitation of columns with reinforced concrete jacketing.
3. A.H. Al-Gadhib, M.H. Baluch and M.K. Rahman (2002) Repair and Retrofitting of Deteriorated Reinforce Concrete Structures .The 6th Saudi Engineering Conference, KFUPM, Dhahran, December 2002 Vol 3: pages 147-153.
4. G E Thermou and A S Elnashai (2006), Seismic retrofit schemes for RC structures and local–global consequences Journals of Earthquakes engineering and structural dynamic University of Illinois at Urbana-Champaign, IL, USA.
5. G. D. Lakade, Dr. C. P. Pise, S.S. Kadam, Y. P. Pawar, D. Mohite and C. M. Deshmukh.(2015) Performance of RC Building under Dynamic Forces and Suitability of Strengthening by FRP Jacketing. International Journal of Civil Engineering and Technology, 6(9), 2015, pp. 147-159.
6. Ahmed Ghobarah & A. Said (2001), " Shear strengthening of beam -column joints", McMaster University, Hamilton, Ontario L8S 4L7, Canada, Engineering structures 24 (2002) 881-888, Issue 20 November.
7. Sumit Bhardwaj & Sabbir Ahammed Belali (2015),"A Review on retrofitting", Review paper or Case study ,Amity university noida,SSRG international journal of civil engineering (SSRG- IJCE),Volume 2, Issue 3 March.
8. Bhavar D.O,Dhake P. D & Ogale R. A (2013) " Retrofitting of existing RCC Building by Method of jacketing", International journal of research in modern engineering , Vol 1,Issue 5 june.