



3 1761 06208504 8

UNIVERSITY PHYSICS

PART II.

H. S. CARHART







Digitized by the Internet Archive
in 2007 with funding from
Microsoft Corporation

PHYSICS

FOR

UNIVERSITY STUDENTS

BY

HENRY S. CARHART, LL.D.

PROFESSOR OF PHYSICS IN THE UNIVERSITY OF MICHIGAN

PART II.

HEAT, ELECTRICITY, AND MAGNETISM

ALLYN AND BACON

Boston and Chicago



Copyright, 1896,

BY HENRY S. CARHART.

PREFACE.

THE present volume has been written in pursuance of the plan outlined in Part I.; it is from the same point of view, and the same method has been followed as far as practicable.

The favor with which the first part of the book has been received by teachers of experience leads the author to hope that this second part may be found to furnish a satisfactory completion of the elementary course in Physics which the two were designed to furnish.

The author would take this occasion to acknowledge the courtesy of The Cambridge Press in granting permission to reproduce a few illustrations from Glazebrook's *Heat*; he would also make acknowledgment of similar indebtedness to Professor Barker for illustrations from his *Physics*; and to Assistant Professor G. W. Patterson, Jr., for cordial assistance in proof-reading.

UNIVERSITY OF MICHIGAN, February, 1896.

CONTENTS.

HEAT.

CHAPTER	PAGE
I. Nature of Heat	1
II. Temperature and its Measurement	9
III. Expansion	23
IV. Measurement of the Quantity of Heat	42
V. Fusion	54
VI. Vaporization	65
VII. Transmission of Heat	90
VIII. Radiation and Absorption	104
IX. Thermodynamics	126
X. Kinetic Theory of Gases	142

ELECTRICITY AND MAGNETISM.

XI. Electric Charges	150
XII. Electrification by Influence	171
XIII. Electrical Potential	188
XIV. Capacity and Condensers	201
XV. Atmospheric Electricity	224
XVI. Primary Cells	233
XVII. Electrolysis	255
XVIII. Ohm's Law and its Applications	273
XIX. Thermal Relations	286
XX. Properties of Magnets	305
XXI. Magnetic Effects of a Current	329
XXII. Electrodynamics	343
XXIII. Electromagnetism	352
XXIV. Electromagnetic Induction	372
XXV. Dynamos and Motors	397
XXVI. Electric Oscillations and Waves	422
APPENDIX	433
INDEX	437

REFERENCES.

The letters, enclosed in parentheses accompanying the headings of articles, refer to the following books, numerals denoting pages :

B., Barker's *Physics*.

G., Glazebrook's *Heat*.

J. J. T., J. J. Thomson's *Elements of Electricity and Magnetism*.

M., Maxwell's *Theory of Heat* (Tenth Edition).

Max., Maxwell's *Treatise on Electricity and Magnetism*.

P., Preston's *Theory of Heat*.

S., Stewart's *Elementary Treatise on Heat* (Sixth Edition).

T., Tait's *Heat*.

Th., Thompson's *Elementary Lessons in Electricity and Magnetism*.

Tyn., Tyndall's *Heat as a Mode of Motion*.

The numerals enclosed in parentheses in the body of the text refer to articles. When the reference is to Part I., it is indicated by the letter I. before the number denoting the article.

HEAT.

CHAPTER I.

NATURE OF HEAT.

1. **Heat a Form of Energy.** — The conclusion to which many remarkable investigations of the present century lead is that heat is a form of energy, and that it can be transformed into mechanical work. We are not at liberty to regard it as a substance, because it can be produced from something which is not a substance, and it is inexhaustible in amount. Heat is not motion, but the energy of motion. It depends on the confused and incessant activity of the molecules of matter.

Heat is, moreover, the lowest form of energy, or the form which all other kinds of energy tend to assume whenever any transformation occurs. It is the form taken by unavailable energy when work is spent in friction, and by the unconverted residue when available energy is employed to do work, as in the heat-engine. When energy is transformed in any operation in such a way that it is not directed by the mechanism of the transformation into some specialized form, it always manifests itself as heat. Thus, when a piece of zinc is acted on by sulphuric acid, the energy of the chemical union appears as heat, unless the conditions are such as to constitute a voltaic cell, when most of it appears first as the energy of an electric current.

The kinetic energy of a bullet is converted into heat when it strikes the target; the energy of meteors becomes heat by friction with the air; the energy of combustion is heat, and only a small portion of it can be reconverted into useful forms. The energy of sound, of winds, and of waves, of lightning and of falling water, ultimately fritters down into diffused heat.

2. **Heat in Material Bodies (P., 34).** — In primitive times heat was supposed to be a subtle fluid. The excess of it in a body caused it to be hot; its deficiency left it cold. After many controversies it was demonstrated to be without weight, and was therefore included among the imponderables. It was assumed that this heat-fluid, or *caloric*, was indestructible. The quantity of heat in the universe was, therefore, considered to be constant.

To explain the physical changes produced by heat, it was imagined that caloric entered into combination with material bodies. Thus, water was conceived to be a compound of ice and caloric, and steam was ice with a larger proportion of caloric. The heat generated by friction, grinding, or compression was said to be forced out of bodies or to be due to their lessened capacity for heat. Such explanations, which now seem to partake of the grotesque, were regarded by many philosophers as plausible and satisfactory, and the theory persisted down into the present century. But the burden of proof which it had to sustain became at length too great, and it was abandoned, as the material theory of light had been before it.

The real nature of heat had been foreshadowed in early times. Bacon expressed the opinion that heat consists in a "brisk agitation" of the parts of a body, and Robert Boyle concurred in this opinion. The non-materiality of

heat was demonstrated by Count Rumford (Benjamin Thompson) and by Sir Humphrey Davy at the beginning of the present century, but their demonstration was not accepted till Joule had determined the "mechanical equivalent" of heat, or the work that the quantity of heat constituting the unit of measurement is capable of doing (86). This equivalence between heat and work is independent of any theory of molecular motion. It is a demonstration that heat is a form of energy, because heat and energy in other forms are reciprocally convertible.

The precise theory of the molecular motions concerned in heat has not yet been made out. We know that the ultimate particles or molecules of a body are in a state of perpetual agitation. In gases this motion is in part vibrational, in part probably rotational, and in part motion of translation, the molecules colliding and rebounding, but having at a given temperature a mean velocity of which we have a fair knowledge (98). In liquids their movements are much more restricted, but diffusion shows that they enjoy a good degree of freedom of motion. In solids the molecules are still more limited in their movements. Each molecule is restricted to a very small space which it never leaves, and is within the limits of the action taking place among contiguous molecules. In solids and in liquids a part of the heat-energy is potential, since each molecule is acted on by its neighbors. The remainder is the kinetic energy of molecular motion. The heat-energy of gases is all kinetic, but it is not known how the total kinetic energy of a molecule is divided between the three components of motion — vibration, rotation, and translation.

3. Rumford's Experiment. — During the operation of boring brass cannon at the military arsenal in Munich in

1799, Rumford was impressed with the large amount of heat generated by the abrasion of material with the boring tool. The calorists ascribed the heat to the diminished capacity of the abraded metal for heat. Rumford sought to test this explanation by comparing the amount of heat contained in equal masses of the solid and the abraded metal by raising them to the same temperature of boiling water and observing the rise of temperature of the equal masses of water in which they were cooled. No difference could be detected.

In this famous experiment, which disproved the material theory of heat, a blunt steel borer $3\frac{1}{2}$ inches wide was turned by horse power 32 times a minute inside a brass cylinder weighing 113 pounds. In two and a half hours the water surrounding the cylinder and weighing $18\frac{3}{4}$ pounds was heated from 60° F. to the boiling point. Only 4,145 grains of the metal were abraded. Rumford correctly concluded that this large amount of heat, which appeared to be inexhaustible, could not have been derived from the abraded metal, which at the same time had not lost any of its capacity for heat. After showing that all other conceivable explanations were excluded by the conditions, he concludes as follows: "It is hardly necessary to add that anything which any insulated body, or system of bodies, can continue to furnish without limitation cannot possibly be a material substance; and it appears to me extremely difficult, if not quite impossible, to form any distinct idea of anything capable of being excited and communicated in the manner heat was excited and communicated in these experiments, except it be MOTION."

Rumford's experiment was complete except that he did not proceed to determine the numerical relation between the work done and the heat generated; but it must be

remembered that the law of Conservation of Energy was not then known.

4. **Davy's Experiment.** — About the time of Rumford's experiment, Sir Humphrey Davy devised another to test the current explanation of the heat generated by friction. By means of clock-work he arranged to produce friction between two blocks of ice, in such a manner that no heat could be received from external objects; and he thus demonstrated that the ice could be melted by the friction of one block against the other. The fusion took place only at the surface of contact between the two, and they were almost completely converted into water, whose capacity for heat, according to the supposition of the calorists, was diminished. Davy reasoned that heat must have been generated, because water by universal concession contains more heat than ice. But this heat could not have come from the diminution of thermal capacity, because the thermal capacity of water is much greater than that of ice. This was Davy's first contribution to science; and he concluded, though with some apparent lack of confidence, that friction produces heat, and that there is no such thing as caloric, or the matter of heat. It was not till 1812 that he asserted with firm conviction that

“The fundamental cause of the phenomena of heat is motion, and the laws of its communication are precisely the same as the laws of the communication of motion.”

The first of these propositions should now be amended in view of the doctrine of the Conservation of Energy. Heat is not motion, or a mode of motion, but the Energy of Motion. The second of Davy's statements remains entirely correct.

These experiments of a public officer in the prosecution

of his official duties, and of a young scientific man, destined later to become famous in both physics and chemistry, laid the foundation of the modern dynamical theory of heat, which was developed later by Joule, Hirn, Clausius, and Maxwell.

5. **Radiant Heat.** — One of the ways in which a hot body loses heat is by radiation. We may feel the warmth of the sun's rays when the temperature of the air is below freezing. Approach to a hot stove is readily perceived in the dark without contact. The air is not the medium by which the heat is conveyed, for radiant energy is transmitted more readily through the most perfect vacuum than through air. The process by which heat is transferred from one body to another without heating the medium through which it passes is called *radiation*. It is customary to speak of the radiant energy, which becomes sensible heat when absorbed by material bodies, as Radiant Heat. But while heat is certainly communicated from one body to another by the vibrational process of radiation, we are not at liberty to speak of what passes between them as heat, since it does not warm the air through which it passes; for the passage of heat through any medium as heat always warms the medium. When heat leaves a radiating body, it is wholly transformed into radiant energy. Energy in the radiant state or form of transmission is not the heat which gives rise to our sensation of warmth. It is reconverted into heat only when it reaches our bodies or other absorbing substances. We have no evidence that the radiant energy from the sun is heat during its passage through interplanetary space. Heat is converted into radiant energy at the sun, and it is transmitted as radiant energy through the intangible ether as a medium. It

becomes heat again only when it is absorbed by material bodies and becomes the energy of irregular molecular vibrations. But the term Radiant Heat has come into scientific use on account of the intimate connection between heat and radiation; its use does not imply the existence of a new kind of heat, but refers to the thermal aspect of radiation.

6. Radiant Heat and Light Identical. — It was formerly supposed that the radiations from the sun, or any other self-luminous body, consisted of three distinct kinds, having different distributions in the spectrum; viz., the luminous, the heat, and the actinic rays. The last were supposed to be the only ones concerned in the process of photography; but the progress of physical science has shown that the differences ascribed to radiations are rather differences in the receptive apparatus (I., 217). Radiant heat and light are identical, but are perceived by us through different avenues of sensation. Radiations of identically the same wave-length produce the impression of light when received through the eye, and of radiant heat when detected by the sense of heat or by a thermometer. All radiations when stopped by the appropriate absorbing body are transformed into sensible heat; that is, heat which affects the sense of heat or a thermometer. The limit in their effect upon the eye is imposed by the receptive mechanism; and their possibilities in initiating chemical changes are determined by the sensitizing substances used. The most widely applicable method of exploring the spectrum is by heat effects. Direct optical methods can be applied to only about three or four per cent. of the wave-lengths actually measured; and as yet photography is much more limited than the method of exploration developed by Langley, which depends

on changes produced by small variations in temperature due to absorbed heat. The only difference between heat and light objectively is not a fundamental one, but at most only a difference of wave-length.

It is known that there are waves too short to produce vision, and these have heat energy, though it is small in amount and difficult to measure. There are other waves too long to excite the eye, and they represent more energy than those lying within the range of vision. But all waves of ethereal commotion are propagated by the same physical process. Waves which are too long to excite vision may yet warm our bodies, or give rise to electromagnetic or electrical phenomena.

The distinguishing characteristic of radiant heat is that it travels through any uniform medium in straight lines or rays like light, for it is intercepted by a screen in the same manner as light. It is also reflected in accordance with the same laws as light, for the focus of a mirror for radiant heat is the same as its focus for light. It is not propagated instantaneously, but its speed in a vacuum is identical with that of light. This is demonstrated by the simultaneous disappearance and reappearance of the light and heat at the time of a solar eclipse. In fact, since radiant heat and light are absolutely identical throughout the visible spectrum, it follows that all the physical laws which have been demonstrated to hold for light must also apply to radiant heat, for none of these laws depend on wave-length.

CHAPTER II.

TEMPERATURE AND ITS MEASUREMENT.

7. **Definition of Temperature.**—The words *hot* and *cold* are primitive ones, and refer to our impressions received through the sense of heat. It is now generally conceded that this sense is independent of the sense of touch, with which it has often been confused. When we are warmed by radiation from a fire, or by the rays of the sun, this change of physical condition is made known to us as a sensation received through a specialized sense-organ, which is distinct from the visual sense, but more closely related to it than to that of touch or smell, since the impressions of warmth and of light are both excited by the same radiations from a hot body.

When the surface of our bodies is brought into contact with other bodies, they may give to us the feeling of either coldness or hotness, and we may be able to assert that one body is hotter than another. By means of these sensations we might arrange a collection of bodies *of the same kind* in a series of relative hotness, and should be able to assert that any one of them is hotter than all others which we place below it in the series. This order of hotness is scientifically expressed by means of the word *temperature*. The body which gives to us the sensation of superior hotness is said to be of a higher temperature than another of the same kind which feels cooler.

If now one of two bodies of equal hotness be heated by

a flame, we ascribe its rise of temperature to the possession of a larger amount of what we call heat. This simple inference is entirely justifiable, and is independent of any theory of heat. Imagine, now, this heated body placed in contact with a cooler one. We can readily determine that the hotter one becomes cooler and the cooler one hotter and if sufficient time be allowed, the process continues till both are of the same temperature. Hence we say that in the attainment of this equilibrium heat has passed from the hotter body to the cooler one. This inference is justified by the fact that the application of heat to a body without change of state makes it feel hotter. Hence, temperature may be defined by reference to this phenomenon of the transfer of heat as follows: *Temperature is the thermal condition of a body which determines the transfer of heat between it and other bodies.* If two bodies, *A* and *B*, are placed in thermal communication with each other, one of three results will follow: *A* will become cooler and *B* warmer; *B* will become cooler and *A* warmer; or neither will change in relative hotness to the other. In the first case the temperature of *A* is said to be higher than that of *B*; in the second the temperature of *B* is higher than that of *A*; and in the third their temperatures are equal, and the two bodies are said to be in thermal equilibrium.

Temperature is analogous to pressure of gases. If two vessels in which air has been unequally compressed are made to communicate with each other, air is forced from the vessel of higher pressure to the one of lower pressure till an equilibrium of pressures has been established. The direction of the flow is determined entirely by pressure and not in the least by the relative volumes of the two vessels.

Temperature may be compared to potential in electricity, where the flow is from places of higher to places of lower potential. Similarly heat flows from bodies of higher to bodies of lower temperature.

The sense of heat is, however, a very unreliable means of determining relative temperatures. It may be totally misleading when the comparison is made between bodies of different kinds, having different capacities for heat and different conductivities. Aside from this source of unreliability, the sensations cannot be made an accurate measure of physical properties. In the most favorable cases the judgment can only be trained by frequent comparison with the data furnished by the use of a unit of measure. It is necessary, therefore, to have recourse to some physical change produced by heat for the construction of an instrument to serve as an accurate measure of temperature.

8. Expansion. — One of the most familiar changes due to the increase of the temperature of a body is its increase of volume, or expansion by heat. This physical change is the one commonly employed to measure temperature.

With but few exceptions, an increase in the temperature of a body is attended by an increase in volume. Thus the rails of a railway are not laid in contact end to end in cold weather, but a small space is left for expansion by heat. The tire of a wagon wheel is put on hot, and it shrinks and compresses the wheel on cooling. Gravesand's apparatus consists of a metallic ball which closely fits a ring of the same material when both are at the same temperature. If now the ball be slightly heated, it will expand to such an extent that it will no longer pass through the ring. Clocks and watches, unless carefully compensated, have a slower rate when warm than when cold. This change in

rate is because the pendulum increases in length with temperature, or the vibrating parts have their moments of inertia increased by linear expansion.

A very interesting illustration of expansion is furnished by the creeping downward of heavy metal roofs. If they are free when they expand by heat they expand downward because gravity aids this movement; but when they contract again in cooling, the upper edge is pulled in. The result is that the metal sheet has the motion of a common earthworm, and creeps down the incline by alternately pushing forward its lower edge and drawing its upper one after it. In this way the sheet lead covering the choir of Bristol cathedral is reported by Tyndall to have crept downward at the rate of nine inches a year.

Liquids and gases expand in volume only. Their apparent dilatation is the difference between that of the gas or liquid and the containing vessel. If a liquid and its envelope expanded at the same rate, the liquid would show no relative dilatation and could not be employed in the construction of an instrument for measuring temperature. Let a large glass bulb, or a small Florence flask with a long narrow stem, be completely filled with water up to a convenient point on the stem. On suddenly plunging the flask into hot water the liquid in the tube will at first descend, but as soon as the heat penetrates into the liquid the index in the stem will stop moving downward and will then begin to ascend. The envelope first expands by heat, its increase of volume being indicated by the apparent shrinkage of the water; but finally the dilatation of the water exceeds that of the glass and the index rises. The movement of the index in the stem indicates then only the apparent expansion of the liquid, or the excess of its expansion over that of the glass envelope. This relative

expansion of a liquid contained in a glass envelope is the phenomenon most commonly employed in the *thermometer*, the instrument to measure temperature.

9. **The Mercurial Thermometer.** — The mercurial thermometer consists of a closed capillary glass tube terminating in a bulb or reservoir of a cylindrical, spherical, or other form (Fig. 1). The bulb and a part of the stem are filled with mercury; the remainder of the stem contains only the vapor of mercury. A cylindrical bulb is preferable to a spherical one because the mercury then exposes a larger surface relative to its mass, and so acquires more promptly the temperature of surrounding bodies. A small change in the volume of the mercury in the bulb is readily indicated by the motion of the end of the column in the narrow stem.

All such an instrument can do is to indicate its own temperature; but if it is in sufficiently intimate contact with another body, as when it is immersed in a liquid, it may indicate also the temperature of this other body with which it is in equilibrium.

Mercury is a very suitable thermometric substance, for it fulfils most of the necessary requirements. It can be readily procured in a state of purity. Its coefficient of expansion is large and nearly uniform between the limits within which it remains liquid, and those limits represent a wide range of temperature. It readily transmits heat through itself, so that all the mercury in the thermometer rapidly comes to the same temperature. It requires



Fig. 1.

less heat to raise the temperature of any mass of mercury through any range than is required for equal masses of most other liquids—that is, its thermal capacity is small. When therefore it is brought into contact with a warmer body, at whose expense its temperature rises, this body in general loses but little heat and its temperature is not changed by the application to it of the instrument intended to measure its temperature. Moreover, it does not stick to the tube so much as other liquids, and it is opaque and can easily be seen as a fine thread in the bore. On the other hand, mercury is very heavy, and its weight brings great stress on the bulb. Also its meniscus is not the same when the column rises as when it falls, and on a falling temperature the column is known to descend with an irregular jerky movement.

10. **The Two Fixed Points on a Thermometer.**— For the purpose of making different thermometers comparable, it is necessary to have fixed points of temperature which are invariable and easy of reproduction. The two points universally employed are the temperature of melting ice and the temperature of steam from water boiling under the pressure of a standard atmosphere (I., 101). The former is called for brevity the *freezing point*, and the latter the *boiling point*. The employment of these two points as standards of reference was first suggested by Hooke; they were adopted by Newton in 1701.

The first point is obtained by placing the thermometer in a vessel filled with pounded ice at the melting temperature. It is desirable that the interstices between the lumps of ice should be filled with water while all excess drains off. The thermometer must be completely immersed in the ice and water, and must remain there till the mercury

becomes stationary in the tube. The top of the column is then marked by a fine scratch on the glass.

To determine the boiling point, the thermometer is passed through a hole in the top of a tall vessel, the bottom of which contains boiling water. The thermometer must be completely enveloped in steam, no part of it touching the water. When it has acquired the temperature of the steam it is drawn up till the top of the mercury thread is visible and the point is marked by a scratch. The upper portion of the tall vessel is made double so that the steam may circulate round the inner tube containing the thermometer as a steam jacket to keep the steam up to the boiling point at every part of the thermometer. The bulb of the thermometer is not allowed to touch the water, because the temperature at which water boils varies somewhat with the material of the containing vessel, while the steam escaping from boiling water is always at the same temperature for the same pressure. If the atmospheric pressure is not 760 mms. a correction must be applied, the boiling point rising 1° C. for every 26.8 mms. increase of pressure.

11. **Thermometer Scales (T., 103).** — The distance between the two fixed points on a thermometer must be subdivided into some convenient number of divisions, each of which represents one degree of temperature. The volume of the capillary bore of the tube between the freezing point and the boiling point represents the total expansion of the mercury from the one temperature to the other. A degree of temperature is then that rise of temperature which causes the mercury to expand some definite fraction of its entire expansion between the freezing and boiling points.

Three scales of uniform graduation are in common use :

Fahrenheit's Scale. Fahrenheit about 1714 constructed the first thermometers with a uniform graduation of the scale, and this scale is still the one most commonly used in English-speaking countries. The distance between the two fixed points is divided into 180 parts of equal volume. The freezing point is marked 32° , and the boiling point is therefore 212° . The graduation is usually continued below 32° . One degree F. is that rise of temperature which causes $\frac{1}{180}$ th of the expansion in volume between the freezing and boiling points.

The Centigrade Scale. Celsius of Upsala divided the scale between the fixed points into 100 equal parts. The freezing point he marked 0° and the boiling point 100° . This scale is obviously simpler than that of Fahrenheit, and is in general use among scientific men in connection with the metric system of measurement. One degree C. is longer than 1° F. in the ratio of 9 to 5.

Réaumur's Scale. In this scale the freezing point is marked 0° , and the boiling point 80° . It is in use for domestic purposes on the continent of Europe, but has little to commend it, except that it avoids Fahrenheit's fault of a misplaced zero.

In all three scales the graduation is often extended below zero and above the boiling point.

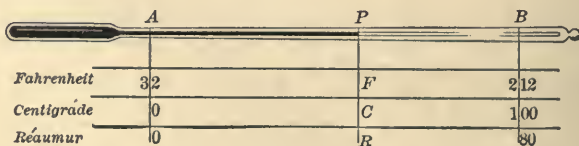

Fig. 2.

12. Comparison of Thermometer Scales (G., 12; T., 105).—To compare corresponding readings on the three scales, let us suppose the three attached to the same

thermometer (Fig. 2). Let A be the freezing point, B the boiling point, and P the head of the mercury column; also let F , C , and R be the readings on the three scales respectively corresponding to the point P .

Then, since AP is the same fraction of AB measured by either scale,

$$\frac{F - 32}{180} = \frac{C}{100} = \frac{R}{80}.$$

The readings on either scale below zero must be treated as negative. It must be noted also that the zero of Fahrenheit's scale is displaced 32° in comparison with the zero of the other two. For Fahrenheit readings therefore 32° must be subtracted algebraically to find the number of degrees between the freezing point and the reading. Thus, 50° F. is $50^\circ - 32^\circ = 18^\circ$ above freezing; and -10° F. is $-10^\circ - 32^\circ = -42^\circ$, or 42° below freezing.

13. Change of Zero (P., 115). — A thermometer should not be graduated for several months after filling with mercury. It has been found that the volume of the bulb slowly decreases for a long period after being strongly heated. Glass is in some degree plastic, and a gradual molecular readjustment goes on after it has been strained or heated. This decrease of the capacity of the bulb raises the zero point on the stem. The correction at the zero point even on standard thermometers may often amount to as much as 0.7° C., though it rarely equals 1° C.

Besides this progressive and permanent change, there is another temporary one which may be observed after a thermometer has been heated in boiling water. It is therefore customary to determine first the freezing point and then the boiling point. If the freezing point is determined immediately after immersion in boiling water, it will be

found that it may have been depressed as much as $0^{\circ}.3$ C., and it will not recover its former value until ten days or more have elapsed.

If the fixed points have been found with the thermometer in a horizontal position, it should be used horizontally; or if they have been found in a vertical position, the thermometer should be used vertically. The reason is that the hydrostatic pressure of the mercury column compresses the mercury and enlarges the bulb in the vertical position, and so lowers all the readings. For a similar reason the readings of unprotected deep-sea thermometers are too high, because the bulb is compressed by the pressure of the water.

14. The Alcohol Thermometer. — Since mercury freezes at $-38^{\circ}.8$ C. and boils at about 350° C., the mercury thermometer cannot be employed for temperatures beyond these limits. For temperatures lower than -38° C. absolute alcohol has often been used because it freezes only at about -130° C. and its dilatation is even greater than that of mercury. But since the dilatation of alcohol is not uniform at different temperatures, the alcohol thermometer must be graduated by comparison with a standard mercurial thermometer. It can be used only in a vertical position, bulb downward, because the alcohol wets the tube, and time must be allowed after a fall of temperature to permit the liquid to run down.

15. The Air Thermometer (M., 46; S., 70). — For high temperatures and for accurate scientific purposes some form of air thermometer is often used. If a volume of gas V_0 be heated from 0° to 1° under a constant pressure and its increase of volume be v , then its dilatation will be

the same volume v for an equal rise of temperature at any other part of the scale. This law, called the law of Charles, is not rigorously exact, but gases approach it more and more closely at low pressures and high temperatures, or, in other words, in a highly rarefied state. Within certain limits, however, all gases, sufficiently removed from their condensing points, may be regarded as expanding equally. The ratio v/V_0 for one degree Centigrade was found by Regnault to be 0.003665 for air.

This property of uniform expansion may be employed in the construction of a thermometer. The first air thermometer was made by Galileo before 1597. The air was contained in a bulb from which a tube descended to a bottle filled with a colored liquid (Fig. 3), or was bent twice at right angles and terminated in an open bulb. This thermometer is filled by heating the bulb before the stem is inserted in the liquid. On cooling, the air contracts and the liquid rises in the stem. Then if the temperature changes, the liquid column moves. But unfortunately the instrument is also affected by any change in atmospheric pressure, and can therefore be used only as a thermoscope unless it be greatly modified and made more complicated.

The first use to which the air thermometer was applied was by physicians to obtain the temperature of the human body. The patient took the air bulb in his mouth, and the extent to which the liquid column descended indicated to the observer whether the patient had a fever.

The simplest form of air thermometer is the one employed by Boyle in 1665. It was composed of a glass bulb from

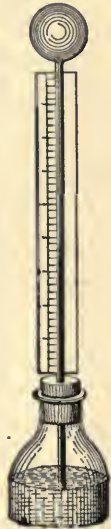

Fig. 3.

which rose a long stem containing a drop of mercury or sulphuric acid to separate the air within from the external atmosphere (Fig. 4). As the temperature rises, the air within expands and drives the liquid index before it.

The dilatation of air is about twenty times as great as that of mercury for the same range of temperature. Hence a thermometer filled with air is much more sensitive than one filled with mercury. For any given range of temperature it has been found that air and mercury thermometers agree closely, though not exactly.



Fig. 4.

It is worth while to point out that the only reason we have for asserting that the thermal value of the successive degrees of a well-calibrated mercury thermometer are the same is that they correspond closely with those of the air thermometer. But, strictly speaking, it is impossible to prove the law of Charles with precision, for its experimental demonstration implies the possession of an accurate instrument for measuring temperature. There are, however, theoretical reasons for believing this law to be exact when the gas is in a state of extreme tenuity and the molecules are so far apart as to exert no influence upon one another. It is then called a perfect gas.

The practical methods of using air as a thermometric substance are described in memoirs and large treatises. A description of one form will be found in a later chapter (26).

16. The Absolute Zero (M., 48, 213). — The air thermometer in the form of a straight tube of uniform bore may be employed to illustrate the meaning of the

“absolute zero of temperature,” or, better, the “zero of absolute temperature.”

Let a long narrow tube be closed at one end, and let air be confined and separated from the external air by a short cylinder of oil, mercury, or sulphuric acid. We shall assume that the pressure on this enclosed air is maintained constant.

Let the point marked *F* (Fig. 5) be the position of the surface of the enclosed air or index cylinder when the tube is in melting ice, and let *B* mark the position of the index for the temperature of boiling water. The question then arises, What temperature will be indicated at the bottom of the tube, if the uniform graduation is carried down there, and what is its meaning?

The first question is easily answered. Let *x* equal the length *AF* on the same scale as *FB* is 100 divisions. Then we know that the volume of the portion of the tube between *A* and *F* is to the volume of *AB* as 1 is to 1.3665, since 0.3665 is the dilatation of air for 100° C. Then

$$x : x + 100 :: 1 : 1.3665.$$

Whence $x = 272.85$, or in whole numbers 273. The bottom of the tube will then be marked -273° . This point is called “absolute zero.” The meaning of it is that if the law of Charles should continue to hold down to the temperature -273° C., the volume of the gas would become zero, or the air would be entirely devoid of heat. Now, while it is not supposed that the contraction of a gas would continue at the same rate down to any such temperature, still this is a convenient point from which to reckon temperatures, because the volume of a perfect gas is simply proportional to its temperature



measured on this scale. Temperatures on the Centigrade scale are converted into corresponding readings on the absolute scale by adding 273° .

It is important to know that the scale of the air thermometer agrees almost exactly with that derived from thermodynamical considerations. The agreement has been experimentally verified between the limits 0° C. and 100° C.

PROBLEMS.

1. Convert the following readings on the Fahrenheit scale into the corresponding degrees Centigrade: 60° , 28° , -20° .
2. Convert the following readings on a Centigrade thermometer into degrees of the Fahrenheit scale: 15° , -10° , -20° .
3. At what temperature will the Fahrenheit and Centigrade scales read the same?
4. At what temperature will the reading of the Fahrenheit scale be double that of the Centigrade?
5. At what temperature will the reading of the Centigrade scale be double that of the Fahrenheit?
6. If a thermometer scale were marked 10° at the freezing point and 60° at the boiling point, what would 40° on this scale mean in Centigrade degrees?
7. A thermometer tube with uniform bore has 5 C. divisions to a cm.; how many F. divisions to the cm. would there be?
8. The testing of a Centigrade thermometer shows that the freezing point reads $+0^{\circ}.6$ and the boiling point 101° . What is the meaning of 50° on this scale if the tube is uniform?
9. The latent heat of fusion of ice on the Centigrade scale is 80; find it on the Fahrenheit scale.

CHAPTER III.

EXPANSION.

17. The Cubical Dilatation of Solids (S., 27; P., 157).

— The expansion of solids and liquids has already been alluded to in the last chapter. The property of a thermometric substance which is utilized to indicate temperature is its increase in volume with heat.

Let V_0 be the volume of a body at zero and V its volume at t° . Then if the increase of volume v for an increase of one degree in temperature is constant at different parts of the scale, we have

$$vt = V - V_0,$$

or
$$V = V_0 + vt = V_0 \left(1 + \frac{v}{V_0}t\right) = V_0 (1 + kt).$$

The constant k is called the coefficient of cubical expansion. It is equal to v / V_0 , or the expansion per unit of volume when the temperature rises from 0° to 1° C. This is sometimes called the zero coefficient. If, for example, 1 c.c. of iron at 0° becomes 1.003546 c.c. at 100° C., then 0.00003546 denotes the mean coefficient of cubical dilatation of iron between these two temperatures.

While the equation $V = V_0 (1 + kt)$ is a very near approximation, it is not rigorously exact. Each substance has its own constant k .

Since the volume of any mass of a substance is inversely as its density, we may write

$$d_0 = d(1 + kt).$$

Whence

$$k = \frac{d_0 - d}{td}.$$

This formula is the basis of a method of measurement which depends on the determination of the density of a solid at different temperatures.

The general law of the dilatation of solids assumes that they expand when heated and recover their initial volume when restored to their initial temperature; that is, that under a constant pressure the volume is a function of the temperature.

Neither of these assumptions is rigorously correct. It has been found that Rose's fusible-metal expands to a maximum, after which, if the temperature be increased, it contracts. So also Fizeau found that iodide of silver contracts regularly when heated between 10° and 70° C. It has since been determined that it reaches a point of maximum density at 116° C., at which point on cooling it passes from the amorphous into the crystalline state.

Neither is it true that the restoration of an antecedent temperature always restores a body to the corresponding volume. If some bodies, like glass, are cooled suddenly, the molecules have insufficient time to arrange themselves in accordance with their mutual attractions. Hence certain stresses are set up which may produce a slow change in volume as they adjust themselves to zero.

The purpose of annealing glass and metals by slow cooling is to give time for the forces of cohesion to adjust themselves without constraint. The annealed body is then much tougher. It is not much in error to say that when

bodies are heated and then very slowly cooled, they return to the same volumes at the same temperatures.

18. **Linear Expansion.** — If the distance between two transverse parallel lines on a metallic bar is l_0 at a temperature of 0° and l at t° , the increase in length is $l - l_0$. This linear expansion is found to be nearly proportional to the length and to the rise of temperature; and the constant which defines this proportionality, and which depends upon the nature of the body, is called the coefficient of linear expansion. If this coefficient is denoted by a , then

$$l - l_0 = al_0t, \text{ or } a = \frac{l - l_0}{l_0t}.$$

Whence $l = l_0(1 + at)$.

It is obvious from the equation for a that the coefficient of linear expansion is the increase which occurs in unit length of a solid when the temperature rises from 0° to 1° C. This is very nearly the same as the mean coefficient between 0° and 100° C. It is the ratio of the increase in length for one degree to the total length at 0° . In the metric system it is the increase in the length of one cm. due to a rise of temperature of one degree C.



Fig. 6.

The expression $1 + at$ is called the *expansion-factor*. It is the ratio of the final to the initial length.

A simple method of showing the expansion of a wire in

length is illustrated in Fig. 6. The wire, which should be about one metre long, is rigidly attached at one end *A* to the stand, and at the other is fastened to a small screw-eye in the long, light wooden pointer *BC*. The pointer is free to turn around a smooth pin at *B*, a point very near the screw eye. Heat the wire by passing through it a current of electricity from some appropriate source. The expansion will be indicated by a wide sweep of the pointer. The wire will cool quickly when the current is off, and the pointer will return to its initial position.

The expansion of a bar may be conveniently illustrated by supporting one end *A* rigidly, as by a weight (Fig. 7), while the other end rests on a thin, straight sewing-needle,

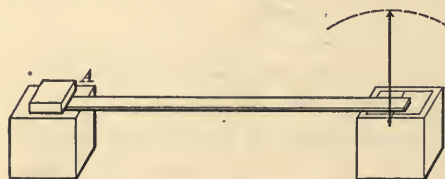

Fig. 7.

which in turn lies on a sheet of plate glass. A slender pointer of straw or foil may be attached to the eye of the needle by a bit of sealing wax, and it

should be counterbalanced.

When the bar is heated by a lamp or a Bunsen burner it lengthens, and the free end advancing rolls the needle. The movement of the pointer indicates the expansion. It should return to its original position when the bar cools.

19. Relation between the Coefficients of Length and of Volume (P., 199). — The coefficient of volume-expansion is three times that of linear expansion; for the volume of a cube, whose side is l_0 at zero, is $l_0^3 (1 + at)^3$ at t° . This volume is also $V_0 (1 + kt)$. But $V_0 = l_0^3$. Hence

$$1 + kt = (1 + at)^3 = 1 + 3at + 3a^2t^2 + a^3t^3.$$

But since a is a very small quantity, its higher powers may be neglected in comparison with the first, or

$$1 + kt = 1 + 3at,$$

and $k = 3a$ nearly.

This relation assumes that the body is isotropic, or has the same physical properties and expands equally in all directions. In the case of crystals this is true only for those of the regular cubic system, which do not cause double refraction of light (I., 226). These dilate uniformly in all directions in the same manner as amorphous bodies.

In general crystals have three rectangular axes of dilatation, and the linear coefficients in these three directions are not identical; the voluminal coefficient is then equal to the sum of the three linear coefficients. It follows that a crystalline sphere at one temperature ceases to be spherical at any other temperature, and a cubical portion of a crystalline body at one temperature will not remain cubical when the temperature changes, unless the crystal belongs to the cubic system.

Crystals belonging to the rhombic system have an axis of crystalline symmetry, and the two coefficients of expansion perpendicular to this axis are equal, or the crystal has the same properties in all directions perpendicular to the axis of symmetry. In this case

$$k = a_1 + 2a_2.$$

Here a_1 is the coefficient of expansion parallel to the axis, and a_2 is the coefficient perpendicular to it.

Optically biaxial crystals dilate unequally in the direction of the three principal axes. Iceland spar and beryl expand in the direction of their principal axis, but contract transversely with rise of temperature.

Mitscherlich concluded that the effect of heat on crystals

is a tendency to separate the molecules in the direction in which their distance is the least, so as to equalize their distances, and to give to the crystal identical properties in all directions.

If such crystals as quartz are strongly heated, their unequal expansion in different directions causes them to burst into small pieces.

20. Measurement of Linear Expansion. — All meth-

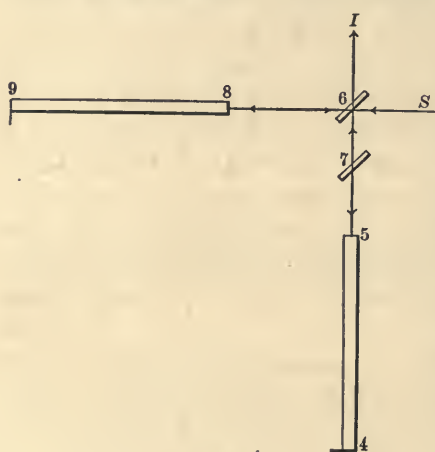

Fig. 8.

ods of determining coefficients of linear expansion involve the exact measurement of the change in length of a body, or some definite portion of it, produced by a known change of temperature. The variations among them consist in the methods adopted to measure this change of length.

By the "interferential method" of Professors Morley and Rogers the small difference in the length of the two bars compared is measured by counting the corresponding number of wavelengths of monochromatic light of known refrangibility. The instrument by which such measurements are made was invented by Professor Michelson, and is called the "interferential comparator." The elements of it are shown in plan in Fig. 8, where 6 is a plate of plane parallel glass so silvered in front that half of an incident ray of light

from S is transmitted and half is reflected. To the near ends of the bars are attached plane mirrors 5 and 8, silvered in front, and to the remote ends, 4 and 9, with the silvered portion extending out at one side of the bar. At 7 is a plate of plane parallel glass of the same thickness as 6, but unsilvered.

In using the apparatus a ray of monochromatic light from S is incident at 6. Half of it is reflected and goes to the mirror 5, from which it is reflected back to 6, where half of this reflected portion is transmitted and passes to the eye of the observer at I . The transmitted half of the incident ray at 6 is reflected from 8 back to 6, where half of it is reflected and enters the eye along with the other component from 5. Since the mirror 6 is silvered on the side facing S , the portion of the light which returns from 8 traverses the glass 6 three times, while the first portion reflected from 5 traverses it but once. Hence the plane plate 7 is introduced to equalize the thickness of glass traversed by the two components which enter the eye of the observer.

If now the two rays have travelled exactly equal distances from the first incidence at 6 to the eye, they will interfere, because a difference of phase of half a wavelength has been impressed on them by the fact that one has suffered internal and the other external reflection at the mirror 6 (I., 214). Any difference of path of the two portions of the incident ray reflected from 5 and 8 will produce a difference of phase at I ; and when this difference of path amounts to an even number of half wavelengths for the particular color employed interference will result.

The form of interferential comparator shown in Fig. 9 was devised by Professor Morley for the determination of

the absolute coefficient of expansion of metals between the freezing and the boiling points of water. The bars to be compared are mounted as shown. Plate 14 is moved by a weight which keeps it in contact with a cross-plate actuated by a precision screw. By means of the interference phenomena described, 5 and 8 and then 4 and 9 are made equidistant from 6. The motion of the bar 8 and 9 in passing from the first position to the second can be

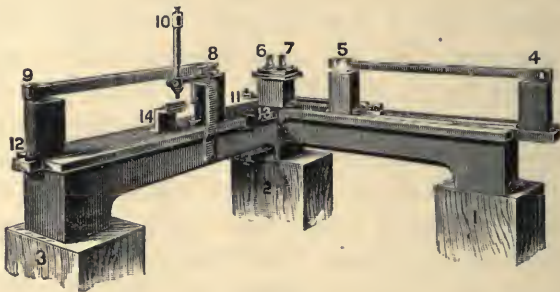

Fig. 9.

measured by counting the interference bands during the motion. A microscope and graduated scale shown at 10 are used to measure the length corresponding to any observed number of wave-lengths of the monochromatic light.

If now one of these bars be kept at a constant temperature and the other one be compared with it in the way described, first at the freezing point and then at the boiling point, the expansion for 100 degrees C. will be measured in terms of a particular wave-length of light as a unit of length.

21. Dilatation of Liquids. — Liquids in general are more expansible than solids. In the case of liquids and gases

the only expansion to deal with is volume expansion. The approximate formula $V = V_0 (1 + kt)$ holds as in the case of solids.

An instrument like a thermometer is well suited to measure the apparent expansion of a liquid, or the excess of its expansion over the volume expansion of the glass envelope. If the absolute coefficient of expansion of the glass is known, the absolute expansion of the liquid can be deduced from the apparent expansion.

The absolute coefficient of expansion of mercury has been determined by Regnault with great accuracy by means of the principle that the heights of two liquids in communicating tubes above their common surface of separation are inversely as their densities (I., 80). The actual investigation involved some modifications and many minute details.

Two vertical iron tubes, ab and $a'b'$, about 150 cms. long, were connected near their upper ends by a horizontal cross-tube aa' (Fig. 10). The cross-tube joining the lower ends b and b' was interrupted at its middle, and two vertical glass tubes were inserted and connected with each other and with a reservoir filled with air, the pressure of which could be varied at pleasure. When the two columns of mercury filling the apparatus are at different temperatures, the mercury will stand at different heights d and d' in the glass tubes; while their upper surfaces near a and a' will be at levels to produce equilibrium at the upper horizontal cross-tube by hydrostatic pressure. The tubes were all

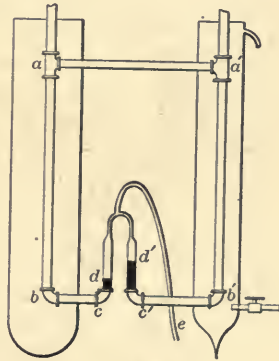

Fig. 10.

enclosed in water jackets, and the two glass tubes were at the same temperature.

The pressures at d and d' are the same, because the two surfaces of mercury are in contact with air under pressure. We may therefore place the pressures on the two sides at d and d' equal to each other. Since the pressure of the short column above a is equal to the one above a' , because they are in equilibrium through the tube aa' , we need to consider only the long columns from a and a' respectively down to the horizontal plane through bb' . Let H be this common height, and let h and h' be the heights of d and d' respectively above the same level through bb' . Also let t be the temperature of the mercury in ab , and t' the temperature of the mercury in all the other tubes. Then

$$\frac{H}{1 + kt} + \frac{h}{1 + kt'} = \frac{H}{1 + kt'} + \frac{h'}{1 + kt'}.$$

The division of H by the expansion-factor reduces it to the height at zero, and this multiplied by the density at zero gives pressure. The same is true of the other terms. But the density is a common factor and disappears.

From this equation

$$\frac{H}{1 + kt} = \frac{H - (h' - h)}{1 + kt'}.$$

Hence
$$k = \frac{h - h'}{Ht' - t(H + h - h')}.$$

It is not necessary to see the tops of the long columns, since the parts above aa' are in equilibrium. H is determined from the apparatus itself, though a correction is needed for a change in temperature. In addition the two temperatures and the difference of level between d and d' must be observed.

By means of this apparatus Regnault made measurements which enabled him to draw up a table of the dilatation of mercury for every 10° from 0° to 350° C. (Appendix, Table I.).

22. Dilatation of Water (B., 293 ; S., 52 ; P., 176).
—Water shows the anomalous property of contracting when heated at the freezing point. This contraction continues up to 4° C.; at this point expansion sets in, so that the greatest density of water is at a temperature of 4° , and its density at 8° is nearly the same as at 0° C.

This peculiar behavior of water is illustrated by Hope's apparatus (Fig. 11). It consists of a glass jar with a tubulure near the top and the bottom to admit thermometers. About its middle is placed an annular reservoir. If the vessel is filled with water at about 10° C., the upper thermometer will show at first a slightly higher temperature than the lower one. If now the trough at the middle be filled with a freezing mixture, the first effect will be the gradual fall of the lower thermometer to 4° C. without much change of the upper one. After the lower thermometer becomes stationary, the upper one falls rapidly till its temperature is reduced to zero and ice forms at the surface. The water at 4° C. sinks to the bottom, while that below 4° is lighter and rises to the top, where the freezing first takes place. For this reason ice forms at the surface of a body of cold water which freezes from the surface downward, instead of from the bottom upward.

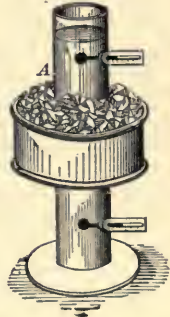

Fig. 11.

The relation between the volume and the temperature of water near the freezing point may be determined by means

of a large thermometer filled with distilled water. If the apparent volumes of the water in glass are plotted as ordinates and the corresponding temperatures as abscissas, the curve is approximately a parabola (*abc*, Fig. 12). The vertex is somewhat above 4°C . This is then the temperature of the least apparent volume. But the observations

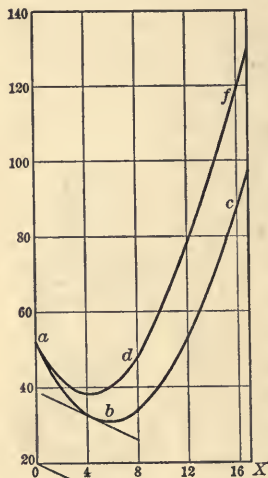

Fig. 12.

for this curve include the dilatation of both the glass and the water. The real volume-temperature curve of water may be found by adding to the ordinates of this one the expansion of the glass. For this purpose, if the glass is assumed to expand uniformly for the small range of temperature included within the observations, it is only necessary to draw a line *OD*, making with the axis of temperatures an angle whose tangent, expressed in terms of the two scales, is the dilatation of the glass for one degree. If the vertical ordinates between *OX* and *OD* are added to the corresponding ones of *abc*, the result is the curve *adf*. The point of least volume, or greatest density, will correspond to the shortest ordinate between *OD* and the curve *abc*. This may be found by drawing a tangent to the curve parallel to *OD*. This tangent touches the curve at *b*, and this is the point of least volume. It corresponds very closely to 4°C .

When the pressure is increased above one atmosphere, the temperature of maximum density of water recedes toward zero. Amagat found the mean rate of recession to

be about 0.025 degree C. per atmosphere. At 144.8 atmospheres the temperature of greatest density was 0.6° C.

Table II. in the Appendix contains the volumes and densities of water from 0° to 100° C. deduced from Rosetti's experiments.

23. Dilatation of Gases — Law of Charles (P., 186; S., 61; G., 100). — The law first enunciated by Charles in 1787 and confirmed later by Rudberg and Regnault is the following: The volume of a given mass of any gas, under constant pressure, increases from the freezing to the boiling point by a constant fraction of its volume at zero. This is therefore known as the law of Charles. For the Centigrade scale the constant fraction is 0.3665 for dry air. This is equivalent to 0.003665 for one degree C. A near approximation is $\frac{1}{273}$. Hence 30 c.c. at 0° become about 41 c.c. at 100° C.

It follows from this law that the formula of dilatation, which has already served for solids and liquids, may be applied to a gas under constant pressure, or

$$v = v_0 (1 + kt).$$

The investigations of Regnault and others have shown that this law, like that of Boyle, is not absolutely exact, but is a close approximation to the truth.

For a perfect gas obeying Boyle's law (I., 103), the product pv of the pressure and volume, for a constant temperature, is a constant. This product is then some function of the temperature, or

$$pv = f(t).$$

It is obvious from this expression that the changes produced by the application of heat to a gas may be investigated by observing the changes of volume under constant

pressure, or the changes of pressure at constant volume. These two methods have been found to give nearly, though not absolutely, identical results.

The method of a constant volume is more readily applied than the other to determine the laws relating to gases. Regnault's apparatus consisted essentially of a large glass bulb of some 600 to 800 c.c. capacity, connected with an open mercury manometer (Fig. 13). At the point h was

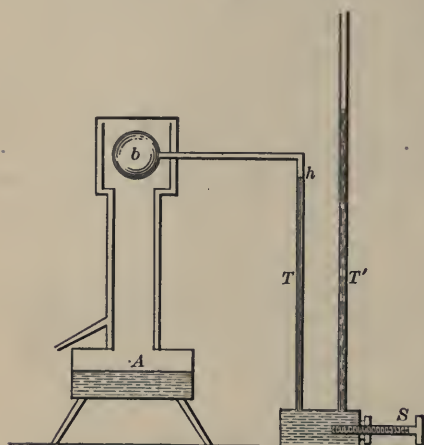

Fig. 13.

a mark, and the mercury was kept at this height by enlarging or contracting the size of the reservoir at the bottom by means of the screw S , which moved a piston out or in, or by some equivalent method. The bulb b was first placed in melting ice, the mercury in T' was brought to the point h , and the difference between the levels of

the mercury in T and T' was measured. By adding the height of the barometer, the pressure on the gas in the bulb was determined.

The bulb was then enveloped in steam and the operations were repeated to determine the total pressure at 100° C. Then, knowing the several temperatures and the volume of the bulb at the different temperatures employed, as well as that of the stem, it was possible to calculate the coefficient of increase of pressure. Regnault found that for dry

air an initial pressure of one atmosphere at 0° C. became 1.3665 atmospheres at 100° C.

With slight modifications in the operations, Regnault found the dilatation in volume under constant pressure. Between 0° and 100° C. the increase in volume was 0.3670.

The table exhibits the results with several gases.

COEFFICIENTS OF DILATATION AND PRESSURE BETWEEN
 0° AND 100° C.

Gas.	Constant pressure.	Constant volume.
Hydrogen	0.003661	0.003667
Air	0.003670	0.003665
Nitrogen	0.003668
Carbon monoxide	0.003669	0.003667
Carbon dioxide	0.003710	0.003668
Nitrous oxide	0.003719	0.003676
Sulphur dioxide	0.003903	0.003845
Cyanogen	0.003877	0.003829

The easily liquefiable gases at the bottom of the list have a somewhat larger coefficient of dilatation than those which are liquefied with great difficulty. Regnault concluded from his elaborate investigations —

(1) That all gases have not the same coefficient of expansion, and that for the same gas there is a slight difference between the coefficient under constant pressure and that at constant volume.

(2) That the coefficient of all gases, except hydrogen, increases with the initial pressure of the gas.

(3) That the coefficients of the gases investigated approach equality as the pressure decreases.

These conclusions correspond with the fact that all gases depart more or less from Boyle's law; but as they are more highly rarefied by reduced pressure, they approximate more nearly to the ideal limit of exact obedience to this law.

24. Volume of a Mass of Gas proportional to Absolute Temperature. — Under the condition of a constant pressure, the law of expansion of a perfect gas is such that increments of volume are proportional to increments of temperature, or

$$t - t_0 = A (v - v_0),$$

where A is a constant. If now the temperature of the least volume of the gas be taken as the zero of the scale (16), and the temperature on this scale be denoted by T , then t_0 is zero, and

$$T = A (v - v_0).$$

For an ideal gas following Boyle's law rigorously, the volume would become zero at the zero of this absolute scale, or

$$T = Av.$$

Hence, under a constant pressure, the volume of a given mass of such a gas is proportional to the temperature on the absolute scale.

The zero of this scale can be calculated from the formula of Art. 23,

$$v = v_0 (1 + kt) = v_0 (1 + 0.003665t).$$

To find the value of t on the Centigrade scale at which the volume v becomes zero, we have

$$0 = 1 + 0.003665t,$$

or

$$t = -273^\circ.$$

25. The Laws of Boyle and Charles combined. — The application of the law of Charles enables us to combine both it and the law of Boyle into one expression, viz., that the product of the volume and pressure of any mass of a gas is proportional to its absolute temperature. This result may be reached in the following manner:

Let v_0 , p_0 , T_0 , be the volume, pressure, and absolute

temperature of the gas under standard conditions, as, for example, 0° C. and 760 mms. pressure.

Also let v , p , and T be the corresponding quantities at temperature T .

Then, applying Boyle's law to increase the pressure to the value p , the temperature remaining constant, we have

$$v_0 : v' :: p : p_0.$$

By changing the pressure from p_0 to p the volume has changed to v' .

Next apply the law of Charles, keeping the pressure constant at the value p , and starting with volume v' . Then

$$v' : v :: T_0 : T.$$

It must be observed that these changes have taken place by two independent, successive steps.

From the first proportion $\frac{v_0}{v'} = \frac{p}{p_0}$; and from the second $\frac{v'}{v} = \frac{T_0}{T}$. Multiplying the two equations together member by member, we have

$$\frac{v_0}{v} = \frac{p T_0}{p_0 T}, \text{ or } \frac{p_0 v_0}{T_0} = \frac{p v}{T}, \text{ a constant};$$

or the product $p v$ is proportional to T , the temperature on the absolute scale. We may therefore write

$$p v = R T,$$

where R is a constant. We see from this expression that in a perfect gas, following these two laws, both the pressure at constant volume and the volume under constant pressure vary directly as the absolute temperature.

26. The Constant-Volume Air Thermometer.—Professor Jolly has devised a constant-volume air thermometer, which is similar in principle to Regnault's apparatus for

the determination of the coefficient of dilatation of gases. It is shown in Fig. 14. The capillary tube is bent twice at right angles, and at *B* is joined to another tube of larger diameter, on which a mark is made near the junction with the capillary. *CE* is a glass tube of the same diameter as

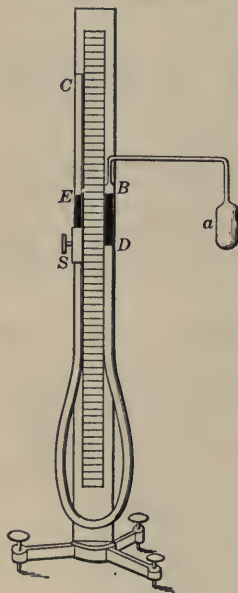

Fig. 14.

BD, and the two are connected by a piece of strong, flexible rubber tubing, which permits *CE* to be raised or lowered so as to keep the level of the mercury at *B*. *CE* may be clamped in any position by the screw clamp *S*. The difference in level of the mercury at *B* and *E*, added to the height of the barometer, both corrected for temperature, gives the pressure of the air in the thermometer. The air in the bulb must be very dry and free from carbonic acid.

For ordinary measurements the difference of level of *B* and *E* may be obtained with sufficient accuracy by means of a scale engraved on a strip of glass before it is silvered. This scale is mounted on the frame supporting the thermometer and tubes.

In reading, the observer avoids parallax by reading the point on the scale touched by the line joining the top of the mercury column and its image in the mirror.

From the relation

$$pv = RT,$$

it is obvious that the pressures of a fixed volume of gas are proportional to the corresponding absolute temperatures, since *R* is a constant.

If, therefore, p_0 be the pressure at 0° C. and p the pressure at some higher temperature t° C., then since the absolute zero is 273 degrees below zero C., we may write

$$273 : 273 + t :: p_0 : p.$$

Whence
$$t = 273 \left(\frac{p}{p_0} - 1 \right).$$

If we employ Regnault's coefficient 0.003665 , the absolute zero is $-272^\circ.85$ C. instead of -273° .

The pressure at zero must be determined by surrounding the bulb of the thermometer with ice and taking readings. Any other temperature is then measured by observing the pressure necessary to keep the mercury at the fiducial point near B .

PROBLEMS.

1. A glass flask holds 200 c.c. of water at 0° C. How much will it hold at 100° C.? The coefficient of linear expansion for glass is 0.0000083 .
2. The density of a piece of silver at 0° is 10.5 . Find its density at 100° C. if its coefficient of cubical expansion is 0.0000583 .
3. The volume of a mass of copper at 50° C. is 500 c.c.; find its volume at 300° C. Coefficient of cubical expansion, 0.0000565 .
4. A brass pendulum keeps correct time at 15° C., but at 35° C. it loses 16 seconds a day. Find the linear coefficient of expansion of brass.
5. A solid displaces 500 c.c. when immersed in water at 0° C.; but in water at 30° C. it displaces 503 c.c.; find its mean coefficient of cubical expansion.

CHAPTER IV.

MEASUREMENT OF THE QUANTITY OF HEAT.

27. **Unit Quantity of Heat.** — Heat as a physical quantity is subject to measurement. For this purpose no knowledge of the ultimate nature of heat is required, but the methods of measurement are based on some established property or effect attributed to heat. Twice as much heat is required to raise the temperature of two grammes of water one degree as of one gramme one degree. The thermal element of such a comparison is limited to an observation of temperatures. The measurement of heat is called *Calorimetry*.

Heat, like other physical quantities, must be expressed in terms of some unit. The unit quantity of heat is the heat required to raise the temperature of unit mass of water one degree. If the unit of mass is the gramme and the unit of temperature the degree Centigrade, the unit of heat is called the *calorie*.

The number of units required to raise the temperature of m gms. of water 1° C. is then m calories; and since the heat necessary to effect the same increase of temperature of 1 gm. of water at any part of the scale is nearly the same, the heat which will warm 50 gms., for example, one degree is almost the same as the heat required to raise 1 gm. 50 degrees. This is demonstrated by mixing equal masses of water of different temperatures and observing

whether the temperature of the mixture is the mean of the two contributing temperatures. It is found that the quantity of heat given out by the warmer mass in cooling through any range raises the cooler mass through the same range.

Since the heat which will warm one gramme of water one degree at different temperatures is not rigorously the same, the definition of unit quantity is often as follows: The unit quantity of heat is the heat required to raise the temperature of 1 gm. of water from 4° C. to 5° C. The same quantity of heat is given out by 1 gm. of water in cooling from 5° C. to 4° C.

28. Thermal Capacity. — The thermal capacity of a body is the number of heat units required to raise its temperature one degree. The thermal capacity of any body of water is numerically equal to its mass in grammes, since the thermal capacity of unit mass of water is the heat unit. But the case is very different with other substances. If equal masses of mercury at 80° C. and water at 20° C. be mixed, the temperature of the whole will be only about 22° C. The heat which the mercury gives up in cooling 58 degrees will heat the water only about 2 degrees, or the thermal capacity of water is about thirty times that of mercury.

This difference in thermal capacities may be further shown as follows: Take a number of metal balls of equal mass, such as lead, tin, zinc, copper, and iron, and place them in boiling water. By means of fine attached wires place them all simultaneously on a flat cake of paraffin supported at the edges, and observe the extent to which the paraffin is melted by each ball. If the plate is not too thick the iron, copper, and zinc balls may melt through, but they will not

go through in exactly the same time. The tin ball will not sink into the wax so deeply, while the lead will melt less than any of the others. The thermal capacity of the lead ball is the smallest, while that of the iron one is the greatest of the series.

The thermal capacity of a substance is the heat required to raise the temperature of unit mass of it one degree. When the unit of heat is defined as above, the thermal capacity of unit mass is numerically equal to the specific heat of a substance.

The specific heat of a substance is generally defined as the ratio between the thermal capacities of equal masses of the substance and of water. Since specific heat is a ratio, it is independent of the unit of measurement employed. The thermal capacity of a body is the product of its specific heat and its mass.

Liquids exhibit differences of specific heat similar to those of solids. If one kilo. of bisulphide of carbon at 0° C. be mixed with one kilo. of water at 60° C., the temperature of the mixture will be about $48^{\circ}.25$ C. The number of calories lost by the water in cooling 11.75 degrees is $1,000 \times 11.75$ or 11,750; hence the thermal capacity of the kilo. of carbon bisulphide is $\frac{11,750}{48.25}$ or 240, and the thermal capacity of 1 gm. of it is 0.240. This is therefore its specific heat. If heat be applied at the same rate to equal masses of water and carbon bisulphide, the temperature of the latter will rise about four times as rapidly as that of the former.

29. **Specific Heat by the Method of Mixtures** (P., 221; G., 34). — The last example illustrates roughly the method of determining specific heats by the method

of mixtures. It is desirable to describe the method somewhat more fully for the purpose of illustrating the thermal principles involved.

Let A_1 and A_2 be two bodies of masses m_1 and m_2 , temperatures t_1 and t_2 , and specific heats s_1 and s_2 . If they are placed in contact they will arrive at some intermediate temperature t . The quantity of heat lost by A_2 will be $m_2 s_2 (t_2 - t)$, and the quantity gained by A_1 will be $m_1 s_1 (t - t_1)$. If we assume that the only interchange of heat going on is between A_1 and A_2 , the heat lost by A_2 will be equal to that gained by A_1 , and consequently

$$m_2 s_2 (t_2 - t) = m_1 s_1 (t - t_1).$$

If A_1 be a mass of water, its specific heat by definition is unity, and therefore

$$s_2 = \frac{m_1 (t - t_1)}{m_2 (t_2 - t)}.$$

This equation gives the mean specific heat between the temperatures t_1 and t_2 obtained by means of the water calorimeter.

It has been assumed that the thermal equilibrium between A_1 and A_2 is reached without loss of heat to other bodies during the period of equalization of temperatures. In practice there will be interchange of heat with other bodies. There will be some loss by radiation, and the heat given to the calorimeter and its fittings must be taken into account. The thermal capacity of the calorimeter is usually expressed in terms of the quantity of water which the number of heat units expressing that capacity would heat one degree. This is called its "water equivalent." The gain of heat by the calorimeter and its fittings must be added to that gained by the water.

Let the water equivalent be m . Then the heat acquired by the calorimeter and its contents will be

$$m(t - t_1) + m_1(t - t_1),$$

and we have $m_2 s_2 (t_2 - t) = (m + m_1)(t - t_1)$,

or
$$s_2 = \frac{(m + m_1)(t - t_1)}{m_2(t_2 - t)}.$$

The correction appears in the formula as an addition to the water in the calorimeter.

To correct for radiation, Rumford arranged the experiment so that the initial temperature of the water in the calorimeter shall be as much below that of the surrounding air as the final temperature is above it. Then the heat gained by absorption during the first part of the experiment will be nearly equal to that lost by radiation during the latter part.

The specific heat of liquids, of powders, and of substances soluble in water may be determined by sealing them in thin glass or metal tubes and proceeding as before. The slowness with which they may then acquire the temperature of the water increases the correction for radiation and reduces the accuracy.

In the case of solids of poor conductivity and soluble in water, another liquid of known specific heat in which they are insoluble may be used in the calorimeter.

There are three other methods of measuring specific heat. The first is founded on the mass of ice which a known mass of the substance will melt. The second depends on the relative rate of cooling of equal masses of water and of the substance. The third is based on determining the amount of steam condensed in raising the temperature of the body through any observed range of temperature. The last method has lately been developed into one of great

scientific value and accuracy. The details will be found in Preston's *Theory of Heat*, p. 236.

30. Variation of Specific Heat with Temperature (S., 307; P., 258).—The specific heat of a substance in general increases with the temperature. This increase becomes quite large in solids near the temperature of fusion. The law governing the variation of specific heat with temperature has not yet been discovered; but the specific heat of any substance may be expressed by the empirical formula

$$s = a + bt + ct^2$$

in which *a*, *b*, *c*, etc., are constants determined by experiment. Such a formula is used only to express the results of a series of experiments, and cannot be regarded as containing any law which holds beyond the range of the experimental series.

The following table embodies the results of Dulong and Petit's experiments:

SUBSTANCE.	MEAN SPECIFIC HEAT.	
	Between 0° and 100° C.	Between 0° and 300° C.
Iron	0.1098	0.1218
Glass	0.1770	0.1990
Copper	0.0949	0.1013
Zinc	0.0927	0.1015
Silver	0.0557	0.0611
Antimony	0.0507	0.0549
Platinum	0.0355	0.0355
Bismuth	0.0308

For higher temperatures platinum has since been found to exhibit a variation, but it is less marked than with other metals. For this reason, a piece of platinum may be used to determine the temperature of a furnace. When it has

acquired the temperature of the furnace, it is quickly removed and plunged into a known mass of ice-cold water. By noting the rise of temperature of the water, it is easy to calculate the approximate temperature of the platinum and hence of the furnace. Such an instrument for measuring high temperatures is called a pyrometer.

According to Hirn the thermal capacity of alcohol attains the value 1.11389 at 160° C., a value superior even to that of water at 100° C.

31. Specific Heat of Carbon (P., 260). — A few substances, notably carbon, exhibit large variations of specific heat with temperature. Weber conducted a series of careful experiments on the specific heat of diamond, and found the following formula for the mean specific heat between 0° and 200° C.:

$$s = 0.0947 + 0.000497t - 0.00000012t^2 \quad . \quad . \quad (a)$$

The total quantity of heat required to raise one gramme of diamond from 0° to t° C. is then

$$q = 0.0947t + 0.000497t^2 - 0.00000012t^3 \quad . \quad . \quad (b)$$

The mean specific heat between 0° and t° C. is obtained by dividing q by t . If the specific heat at any definite temperature is required, it is necessary to find the limiting value of the mean specific heat as the range of temperature is indefinitely diminished; or

$$s = \frac{dq}{dt},$$

where dq is the indefinitely small quantity of heat required to raise the temperature of unit mass through the indefinitely small range of temperature dt . Therefore¹

¹ The formula is obtained by finding from (b) the differential coefficient $\frac{dq}{dt}$.

$$s = 0.0947 + 0.000994t - 0.00000036t^2 \quad . . . \quad (c)$$

At 200° C. the thermal capacity of diamond is therefore nearly three times as great as at 0° C.

Weber showed further that the specific heat of carbon at 600° is about seven times as great as at -50° C. As the temperature rises it approaches a maximum value of about 0.46.

The following are the specific heats of carbon in its different states of aggregation :

Animal charcoal	0.2608
Wood charcoal	0.2415
Coke	0.2008
Graphite	0.2018
Diamond	0.1468

32. Specific Heat of Water (P. 262).—Water has the highest thermal capacity of any known substance except hydrogen, unless it be a mixture of water and twenty per cent of alcohol, which Dupré and Page found to have a thermal capacity five per cent higher than water.

The thermal capacity of water is nearly twice as great as that of ice (0.504), and more than twice as great as that of steam under constant pressure (0.477). Generally speaking, the specific heat of a substance when liquid is higher than when solid.

The heat which will warm a gm. of water one degree will warm 9 gms. of iron, or 18 gms. of silver, or 28 gms. of platinum or gold, or 31 gms. of lead one degree.

The distribution of large quantities of heat in buildings by means of hot water is made possible because of the large thermal capacity of this agent. “The vast influence which the ocean must exert as a moderator of climate here suggests itself. The heat of summer is stored up in the

ocean, and slowly given out during winter. This is one cause of the absence of extremes in an island climate."

Water exhibits a marked peculiarity in the variation of its specific heat with temperature. The formula of Regnault, which is still often quoted, indicates a gradual increase of specific heat as the temperature rises from the freezing to the boiling point. But the experiments of Rowland, in his exhaustive investigation of the dynamical equivalent of heat, were the first ones of sufficient accuracy to show that the specific heat of water first decreases from 0° to about 30° C., and then a gradual increase begins. Rowland's conclusion has been confirmed by Griffiths and by Bartoli and Stracciati, who found a minimum value for the specific heat of water at 20° C. The precise position of this minimum is difficult of determination, since the change in the specific heat near this point is very minute.

33. Atomic Heat of Simple Bodies (P., 256; S., 313).

— In 1819 Dulong and Petit made experiments on simple substances to determine whether their specific heats could be connected by any simple law. From an examination of the specific heats of such substances as iron, lead, gold, silver, etc., these physicists concluded that the atoms of all simple substances have the same thermal capacity. The number of atoms of simple substances in the same mass is inversely as the atomic weight. If therefore the thermal capacity of the atom is the same, the specific heat must be inversely proportional to the atomic weights, "or the product of the specific heat by the atomic weight is the same for all the elementary substances."

This law has been found to hold approximately true for most of the elements which occur in the solid state at

ordinary temperatures, if the specific heats be taken at temperatures sufficiently below the point of fusion. For thirty-two of these substances the mean product is 6.38 and the extremes are 6.76 and 5.7. The atomic weight of hydrogen is the unit.

Since the specific heats of solids are not constant, but vary with the temperature and the physical state, it is to be expected that the product of the atomic weights and the specific heats will exhibit a similar variation from constancy.

34. Specific Heat of Gases. — The specific heat of a gas may be measured in two different ways. It may be measured under the condition of a constant pressure or of a constant volume. The former is called *the specific heat under constant pressure* and the latter *the specific heat at constant volume*. The two are by no means the same. In the latter all the heat applied goes to increase the molecular kinetic energy, while in the former the gas does work in expanding by heat under a constant pressure; and heat must be supplied not only to increase the kinetic energy of the molecules to the same extent as when the volume is kept constant, but in addition enough to do the external work. The specific heat under constant pressure is therefore greater than the specific heat at constant volume. The ratio of the one to the other for air is about 1.41. The importance of this ratio, to which reference has already been made in Sound (I., 120), will be discussed in a later chapter.

It has been found very difficult to measure the specific heat of gases at a constant volume, and till quite recently the difficulties have not been surmounted.

The specific heat of a gas under a constant pressure has

been determined by conducting the dry gas at a uniform flow and constant pressure through two spirals. In the first it is heated to a known temperature, and in the latter it is cooled to the temperature of the bath. The heat given up in the second spiral, or series of chambers, is determined by measuring the rise of temperature of a known mass of water, or by passing the gas through till the temperature becomes stationary, when the heat gained from the gas equals the heat lost by radiation. The mass of gas flowing through is determined by measuring the change of pressure taking place in the known constant volume of the gas-holder. The experimental difficulties are largely due to the small density of gases, so that a large volume must be passed through the calorimeter to produce a measurable change of temperature. This requires time, and the errors due to conduction and radiation are greatly augmented.

The following are Regnault's conclusions respecting the specific heat of gases under constant pressure :

1. The specific heat of all approximately perfect gases, like air, does not vary with the temperature.

2. The thermal capacity of a given mass of such a gas does not vary with its pressure; and therefore the thermal capacity of a given volume of such a gas is proportional to its density.

3. The thermal capacity of equal volumes of the simple gases which are not easily condensible are equal. This equality does not hold for easily condensible gases.

4. The specific heat of easily condensible gases increases with the temperature, like that of solids and liquids.

The specific heat of air is sensibly constant for all temperatures between -30° and 225° C., and under pressures from 1 to 10 atmospheres. The specific heat of carbon dioxide is about doubled at $2,000^{\circ}$ C.

The table is from Regnault's results.

SPECIFIC HEAT OF SIMPLE GASES.

Hydrogen	3.4090	Oxygen	0.2175
Nitrogen	0.2438	Chlorine	0.1210
Air	0.2374	Bromine	0.0555

SPECIFIC HEAT OF COMPOUND GASES.

Ammonia	0.5084	Carbon dioxide	0.2169
Carbon monoxide	0.2450	Hydrochloric acid	0.1852
Hydrogen sulphide	0.2432	Sulphur dioxide	0.1544

PROBLEMS.

1. If 3 kilos. of iron (specific heat, 0.11) at 95° C. are put into 3 litres of water at 10° C., what will be the rise of temperature of the water?

2. The specific heat of mercury is $\frac{1}{80}$ th. If 10 kilos. of mercury be cooled from 100° to 25° C. in 1 kilo. of water, at what temperature was the water before the addition of the mercury?

3. A mass of 500 gms. of copper at 98° C. put into 500 gms. of water at 0° C., contained in a copper vessel weighing 150 gms., raises the temperature of the water to 8°·3 C. Find the specific heat of copper.

4. If 20 gms. of iron at 98° C. (specific heat, 0.11) are immersed in 80 gms. of water at 10° C., contained in a copper vessel whose mass is 15 gms., find the resulting temperature, the specific heat of copper being 0.095.

5. 250 gms. of turpentine, enclosed in a copper vessel whose mass is 25 gms., are heated to 100° C. and immersed in 589 gms. of water at 13° C. in a copper calorimeter weighing 110 gms. The temperature rises to 27.5° C. Assuming the specific heat of copper to be 0.1, find that of turpentine (Glazebrook's *Heat*).

CHAPTER V.

FUSION.

35. **The Fusing Point.** — When heat is applied to a crystalline solid, its temperature rises till it reaches the point where it begins to pass into the liquid form. The temperature then remains sensibly constant till the entire mass has fused or melted, when with continued application of heat it rises again. Conversely when the temperature falls, a stationary point is again reached where the crystallization or solidification sets in, and the body continues to give up heat while the temperature remains fixed. Under the same conditions of pressure the two stationary temperatures coincide, and this point is called the normal fusing point of the substance under the given conditions. Above this temperature the substance will be in the liquid state, and below it in the solid state.

This temperature is called the normal fusing point because under different conditions the fusing point may be different. Thus ice melts normally at 0° C., but under pressure it melts at a lower temperature, and water may be cooled several degrees below zero before it freezes. Other substances present similar abnormal features, and the liquid state may persist at a temperature considerably below the normal point of solidification.

The melting point of ice is sharply marked, and there is no appreciable difference of temperature between the

melting ice and the water into which it passes. This is generally true of crystalline substances, but the case is very different with amorphous solids, like wax, glass, and iron, which cannot be said to have a definite melting point. Such substances soften and become plastic before reaching a more or less viscous liquid state. It is because of this property that glass can be bent, moulded, drawn out into rods and tubes, or blown into various forms. Similarly the softening of wrought iron at a temperature far below the liquefying point permits the metal to be rolled, forged, and welded. In the fusion of wax the outer portions are softer than the interior and presumably at a higher temperature. The experiments of Person go to show that ice begins to soften and to increase in specific heat between -2° and 0° C., and that there is a certain very small range of temperature within which ice softens and melts. The difference between it and wax is then one of degree. Ice represents one extreme of this transition state, and wrought iron perhaps the other.

In general, however, crystalline bodies have a definite fusing point, or a temperature at which they may exist either as a solid or a liquid; while amorphous bodies pass gradually from the solid to the liquid state.

36. Condition of Instability (P., 270). — A liquid which has a definite point of solidification, or whose passage from the solid to the liquid state is abrupt, may be slowly and carefully cooled several degrees below the normal freezing point without solidifying. This condition is an unstable one, and if the under-cooled liquid be jarred, or if a solid fragment of the same substance be dropped into it, solidification will at once set in, with the disengagement of heat. The temperature then rises to the normal freezing point.

Fahrenheit observed that water sealed in a glass bulb remained liquid at a temperature below freezing, but on breaking off the stem rapid solidification followed. Gay-Lussac found that water placed in a small vessel and covered with oil remained liquid down to -12° C. Depretz cooled water down to -20° C. in fine capillary tubes, and Dufour obtained a like result by suspending small drops of water in a liquid of the same density, with which it would not mix.

On the other hand, the surface of very still water freezes sooner than one which is disturbed by the wind. A running stream freezes less readily than a placid one. There is no evidence, however, that the temperature of running water is ever below 0° C. The surface layers of still water cool down to the freezing point by rapid radiation, while the poor conductivity of water (64) prevents the replenishing of the heat from below.

This property of under-cooling is not peculiar to water. It has been observed also in the case of phosphorus. If an over-saturated solution of sodium sulphate, prepared by dissolving the salt in hot water, be placed in a clean flask, it will remain liquid on cooling if undisturbed. But a slight jar, or the introduction of a small crystal of the salt, will start the solidification. When the unstable equilibrium is disturbed crystallization proceeds rapidly with a rise of temperature. The potential energy of the unstable liquid mass is converted into heat.

37. Change of Volume during Fusion. — In passing from the liquid to the solid state bodies undergo a change of volume. In most cases the volume diminishes. Ice, bismuth, type metal, and cast iron are among the exceptions. Cast iron and type metal expand on solidifying, and this expansion

causes them to fill every little line and crevice of the mould. The powerful expansion of ice is attested by the bursting of water-pipes and the rending of rocks by frost. If a short piece of gas-pipe, with a screw cap fitted to each end, be completely filled with water and placed in a freezing mixture, it will burst with a loud report when the water congeals.

Major Williams at Quebec filled a 12-inch shell with water and closed it with a wooden plug driven in with a mallet. When the shell was exposed in the air at -28°C . the stopper was projected to a distance of 300 feet, and a cylinder of ice about 8 inches in length protruded from the hole. Probably some of the water remained liquid till actually relieved of pressure by the giving way of the wooden plug.

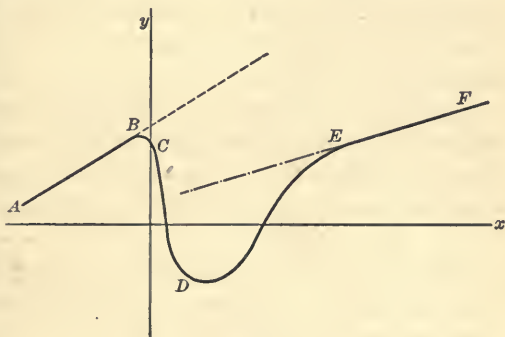

Fig. 15.

The time required for the water to follow the plug a distance of 8 inches was the interval from the liquid to the solid state.

The change of volume of ice has been followed by Erman from the solid to the liquid state by enclosing it in a large bulb like a thermometer and taking readings on the long stem. The continuous change in volume is represented in Fig. 15, where AB represents the expansion of ice. At 0°C . there is a rapid diminution in volume, which continues after the whole mass is liquefied, but at a reduced

rate, up to 4° C., the temperature of the maximum density of water. Beyond this point the liquid at first dilates rapidly along *DE*, and then the uniform expansion of the liquid sets in along the line *EF*. The slope of the line *AB* is greater than that of *EF*, or ice expands by heat more rapidly than water. It is probable from the later experiments of Kopp that the change in volume at zero is much more abrupt than that found by Erman.

In the case of phosphorus the dilatation in the solid state is less rapid than in the liquid; while for a fusible alloy, consisting of one part of tin, one of lead, and two of bismuth, the coefficient of expansion of the solid is the same as that of the liquid.

Numerous examples of substances investigated go to show that there is generally an anomalous dilatation at the fusing point, but that the curve connecting volume and temperature is probably in all cases continuous.

38. Influence of Pressure on the Melting Point (P., 275; T., 119).—That the melting point is affected by pressure was deduced from theory by James Thomson in 1849. His conclusions were verified by his brother, Lord Kelvin, in the same year. The theoretical conclusion was as follows: Bodies which contract on melting have their melting points lowered by pressure, while those which expand have their melting points raised by the same means. Such a result might have been anticipated from the simple consideration that if a substance like water expands on freezing, any pressure which prevents this expansion at the same time prevents congelation. But if the substance contracts on solidifying, then increase of pressure is favorable to this change of state.

Thomson calculated that the freezing point of water

should be lowered by 0.0075 of a degree Centigrade for an increase of pressure of one atmosphere; and the experiments of Dewar, later than those of Lord Kelvin, show a mean reduction of 0.0072 degree Centigrade per atmos. up to 700 atmos. Mousson by enormous pressure lowered the freezing point of water to -20° C.

A rough numerical statement of the result is that under a pressure of one ton per square inch, or of 144,600 gms. per square cm., ice melts one degree Centigrade below its normal melting-point.

The converse conclusion has also been verified by Bunsen, who found that paraffin wax, which melted at $46^{\circ}.3$ C. under atmospheric pressure, melted at $49^{\circ}.9$ C. when the pressure was raised to 100 atmos.

Lord Kelvin has shown that the rigidity of the earth is greater than if it were composed of glass. This conclusion is derived from the phenomena of the tides, which show that the earth does not yield appreciably to the forces which raise them. The great rigidity, and therefore the solidity, of the earth can be accounted for if it be assumed that the materials composing the earth have their fusing point raised by pressure. It has been ascertained that this is true of ordinary lava.

39. Regelation.—The phenomenon of the re-freezing of water from ice melted by pressure, when the pressure is relieved, is called *regelation*. It was first noticed by Faraday. Familiar illustrations of it are the hardening of a snowball under the pressure of the hands, and the passage of snow into compact ice in a roadway, where it is compressed by vehicles and the hoofs of horses. Frozen foot-forms may often be seen to persist in compact ice after the loose snow has melted, and the bottom of a snowbank is not infrequently compressed into clear ice.

Unless the pressure is very great, this solidification occurs only when the snow is soft or near the melting point. The pressure applied then reduces the freezing point and melts those portions of the snow that are subjected to stress, while the water again freezes when the pressure is removed. If two pieces of ice at 0° C. be firmly pressed together, they will adhere by freezing after the pressure is relieved. This may be done even under the surface of warm water. If there is a small range of temperature within which liquefaction takes place, as Person supposed, then the interior of a lump of ice is at a slightly lower temperature than the surface; and when two such surfaces are pressed together, even lightly, they are brought sufficiently near together to give them the temperature of the interior of the block, and as soon as the stress is removed the intervening film of water freezes.

Bottomley's experiment on regelation is instructive. Support a stout bar of ice horizontally by wooden supports at the two ends, and hang on it a weight by means of a copper wire passed over the ice at the middle. The pressure will melt the ice under the wire, and the water passing around it and relieved of the stress will freeze. In this way the wire will cut its way through the ice and the weight will fall, but the bar of ice will remain intact, though the track of the wire through it remains visible. It is well to put a non-conducting link between the weight and the wire to prevent the flow of heat upward from the weight.

When a large body of ice melts in the spring, it will sometimes be found to have a columnar structure consisting of long slender prisms standing vertically. These can be readily detached a foot in length without making more than a small hole through the weak ice. It seems not

improbable that this peculiar structure has been caused by lateral pressure and incipient melting.

Regelation has been invoked to explain the motion of a glacier down its uneven, tortuous channel. A glacier makes its way down its course by very irregular movements. Ice is undoubtedly to some extent plastic, but it is quite probable that regelation plays an important rôle in glacial motion. The ice melts where it is subjected to the pressure of enormous masses above it. This relief by pressure at many points permits the ice to accommodate itself to changes in the channel, and a slow ice-flow is permitted. As soon as the pressure is relieved at any surface the water again freezes. The motion thus takes place by alternate melting and freezing. The middle of the ice stream moves faster than the sides because the weight there is greater and the consequent melting more extensive.

40. The Latent Heat of Fusion. — The nearly stationary temperature maintained by a solid during its passage into the liquid state has already been described. The heat that fuses a crystalline solid does not sensibly raise its temperature. In the language of the caloric theory it becomes latent or concealed. The term *latent heat* has been retained in the modern theory of heat, but we now know that the heat which disappears during fusion ceases to be heat, and is the energy expended or converted into the potential form in the work of giving mobility to the molecules.

The manner of measuring the heat of fusion may be illustrated by the method of mixtures. If two kilogrammes of water, one at 0° C. and the other at 100° C., be mixed, the result will be two kilogrammes at a mean temperature of 50° C. But if a kilogramme of water at 100° C. be

mixed with one of ice at the freezing point, the ice will melt and there will be two kilogrammes of water at about $10^{\circ}.4$ C. The heat lost by the hot water is $1,000 \times 89.6$ calories. A portion of this, viz., $1,000 \times 10.4$ calories, has been employed to raise the ice-cold water from 0° to $10^{\circ}.4$ C., but the remainder has disappeared in the melting of the ice. Therefore to melt 1,000 gms. of ice, $1,000 (89.6 - 10.4)$ equals $1,000 \times 79.2$ calories of heat are required. This is equivalent to 79.2 calories per gm. of ice. In an actual experiment of this kind, the water equivalent of the calorimeter must be taken into account. It is here supposed to be included in the kilogramme of hot water. Experiments of this kind have demonstrated that for every unit of ice melted about 79.2 units of heat disappear.

The latent heat of fusion is defined as the number of calories required to convert one gramme of a substance from the solid to the liquid state without change of temperature.

Let m_1 be the mass and t_1 the temperature of the water and the calorimeter; also let m be the water equivalent of the calorimeter, and let m_2 be the mass of the ice whose heat of fusion l is to be found. If the resulting temperature of the mixture is t° C., then the heat lost by the calorimeter and its contents may be equated to the heat of fusion of the ice and its gain of heat in rising from zero to t° C., or

$$(m + m_1) (t_1 - t) = lm_2 + m_2t.$$

Whence
$$l = \frac{(m + m_1) (t_1 - t)}{m_2} - t.$$

The correction for radiation may be avoided by Rumford's method.

The most probable value of the heat of fusion is 79.25, though Person found 80.02 and Bunsen 80.03, the mean

specific heat of water between 0° and 100° C. being taken by Bunsen as the unit.

41. Heat absorbed in Solution (S., 94). — We have seen that when a solid is changed to the liquid form, heat is absorbed. If the liquefaction is accomplished by solution in a proper solvent without chemical action, heat is still required to give mobility to the molecules, and the temperature of the solution falls. This effect is often masked by the generation of heat by chemical action between the solid and the solvent. If a delicate thermometer be used, such as a thermopile and a galvanometer (see "Thermal Electricity"), the heat absorbed by the solution of sugar in water may be readily detected. A still larger effect is produced by dissolving common salt, while quite a notable reduction of temperature is produced by the dissolving of nitrate of sodium. When glacial acetic acid is dissolved in water, the absorption of heat necessary to increase the fluidity exceeds the evolution of heat by chemical action.

Freezing mixtures are based on the absorption of heat necessary to give fluidity. Salt water freezes at a lower temperature than pure water. Hence, when salt and snow or pounded ice are mixed, both of them become fluid and absorb heat in the transition from one state to the other. By this means a temperature of -22° C. may be obtained.

Many other chlorides, as well as some nitrates, form freezing mixtures with snow or ice. Among them, in the order of effectiveness, are the chlorides of calcium, copper, strontium, ammonium, potassium, and barium.

PROBLEMS.

1. Into a mass of water at 0° C. are introduced 100 gms. of ice at -12° C.; 7.5 gms. of ice are frozen and the temperature of

all the ice is raised to 0° C. If the latent heat of fusion is 80, find the specific heat of ice.

2. How much ice at 0° C. will be melted by 30 gms. of copper (specific heat, 0.095) at 200° C.?

3. A mass of 100 gms. of platinum (specific heat, 0.0355) is heated in a furnace and is then dropped into 200 gms. of water at 0° C.; the temperature of the water rises to 26° C. What was the temperature of the furnace?

4. If a kilo. of copper at 100° C. be placed in a cavity in a block of ice at 0° C., and if 119 gms. of ice are melted, find the heat of fusion of ice.

5. 100 gms. of ice at -20° C. were thrown into 1 kilo. of water at 20° C. contained in a copper vessel weighing 100 gms. When the ice was melted the temperature of the water was $10^{\circ}.15$ C. Find the latent heat of fusion of ice.

CHAPTER VI.

VAPORIZATION.

42. **Four Varieties of Vaporization.** — The passage of a substance into the state of a gas or a vapor is called vaporization. There are four distinct types depending upon the conditions under which the process goes on:

1. *Evaporation*, where a liquid is converted into a gas quietly at a relatively low temperature and without the formation of bubbles.

2. *Ebullition*, or boiling, a rapid evaporation at a higher thermal equilibrium, when bubbles of gas form in the mass of the liquid.

3. The *Spheroidal State*, where quiet vaporization, at a rate between evaporation and ebullition, goes on when the liquid is in apparent contact with a body of relatively high temperature.

4. *Sublimation*, in which a solid passes directly into the gaseous form without going through the intermediate state.

Whether the gaseous condition is reached by one of these processes or another, heat is always absorbed in considerable quantity, although the vapor is at the same temperature as the solid or liquid from which it comes; we have therefore the expression, "latent heat of vaporization." The latent heat of gases is greater than that of liquids; this fact prevents a disastrously sudden conversion

either from the liquid to the gaseous state without chemical change, or the reverse condensation of vapors to liquids, since the heat involved in either operation must be supplied for evaporation, or must be disposed of when generated by condensation (44).

43. Evaporation in a Closed Space. — In a solid the molecules are free to vibrate about fixed positions of equilibrium, but have no motion of translation. In a liquid the conditions of molecular freedom are much more extended. A molecule is so far released from rigid cohesion that it may make its way throughout the entire mass; but its progress is slow because most of its time is spent in encounters with other molecules, of which it is never independent. There is practically no free path to molecular motion in liquids, and the migratory track of any molecule depends upon its innumerable chance encounters with other molecules.

In the interior of a liquid mass a molecule is equally obstructed in its movements in all directions; but at the surface the resultant molecular attraction is normal, and there results the phenomenon of a surface film, called surface tension (I., 93).

Whenever a molecule at the surface of the liquid has a normal component of motion sufficient to carry it through the surface film, it may escape from bondage and wander about in free space. It is then independent of its fellows, except for numerous collisions with them, which determine all the properties of the gaseous state, without, however, absorbing a large portion of time as compared with that of the free motion of the molecule. Such molecules constitute the vapor or the gaseous form of the substance, and the process of entering this state is called *evaporation*.

If evaporation takes place in a closed space, then the free molecules may again come within the range of molecular action at the liquid surface, and may be again entangled and return into the liquid. This process is called condensation. When the number of molecules making their escape equals the number returning through the surface film, there is an equilibrium between the loss and the gain, and at this stage the evaporation is said to cease. This vapor in contact with its liquid is then said to be *saturated*. Its density will remain unchanged unless there is a change of temperature. An elevation of the temperature causes more of the liquid to assume the form of a vapor. If the volume of the saturated vapor is diminished without change of temperature, some of the vapor will condense to a liquid; and if the volume is increased, more of the liquid will evaporate so as to maintain the same vapor density.

Dalton concluded that the presence of inert gases, like air, has no influence on the final density of the vapor; that its only effect is to increase the time required to reach the equilibrium between evaporation and condensation. But Regnault has shown that the maximum pressure of the saturated vapor of water, ether, and some other substances, is slightly diminished when air is present.

The maximum pressures of aqueous vapor in millimetres of mercury are given in the Appendix, Table III.

44. **Ebullition.** — Each molecule carries away heat in evaporation represented by the additional potential energy which it gains in entering the gaseous state. If only a moderate amount of heat is applied, the evaporation is confined to the surface, and it increases till the rate at which heat is supplied equals the rate of loss by evaporation. When the evaporation takes place into open space, the

molecules escaping from the surface may never return to the liquid. There is then no saturated vapor, and the evaporation continues so long as the heat is supplied and any liquid remains. But if the surface is limited in area and the heat supply is in excess, this equilibrium of quiet evaporation cannot be established. The temperature rises till bubbles of vapor begin to form in the interior of the liquid, or at points on the inner surface of the containing vessel. If the vapor pressure is not sufficient to support them as they rise, they collapse and produce the familiar sound of "simmering." With a slightly higher temperature they rise to the surface, expanding in the ascent under reduced hydrostatic pressure; and if the evaporation into them from their enlarged surface is sufficiently rapid, they burst through the surface film and escape. This process of rapid evaporation from the interior, as well as at the surface, is called *ebullition* or *boiling*. An equilibrium is thus established at a higher temperature than the preceding, and this temperature is called the boiling point of the liquid. It is constant for the same pressure.

If the heat be supplied at a still more rapid rate the temperature of the liquid does not rise higher, but the boiling is more violent. So long as the pressure remains the same, ebullition goes on at any rate of heat supply in excess of the rate at which silent evaporation at the surface can dispose of it. The vaporization is then no longer confined to the free surface, but takes place in the interior into small bubbles initiated by expanding air, disengaged from the liquid by heat, or by other bodies which are very active in separating vapor from the heated liquid.

When the air has been all boiled out and the containing vessel is clean, the temperature of water may rise several degrees above the normal boiling point. Ebullition then

sets in with almost explosive violence, and proceeds till the excess of heat, due to the elevation of temperature above the normal boiling point, is disposed of. This abnormally high boiling point of air-free water probably accounts for many explosions of stationary boilers at the moment when steam is first drawn from them after fresh firing. As a measure of precaution, a fresh supply of water containing air should be pumped in before the temperature rises to the boiling point.

The boiling point is the temperature at which the liquid boils or gives off bubbles of its own vapor. It has been found by experiment that *at the boiling point the saturated vapor is given off at a pressure equal to that sustained by the surface of the liquid.*

45. Effect of Pressure on the Boiling Point (T., 135).

— The work done by heat in ebullition is partly internal and partly external. The internal work consists in separating the molecules beyond the range of molecular attraction. The external work depends upon the fact that the liberated vapor is formed under pressure. The work done is measured by the volume of vapor formed multiplied by the pressure on it per unit area. Since



Fig. 16.

this external work is diminished by diminishing the pressure, the lower the pressure the lower the boiling point.

Under diminished pressure water boils at a reduced temperature. A familiar form of experiment to demonstrate this fact consists in boiling water in an open flask till the air is nearly all expelled by the steam. The flask is then tightly corked and inverted (Fig. 16). The boiling ceases, but is renewed by

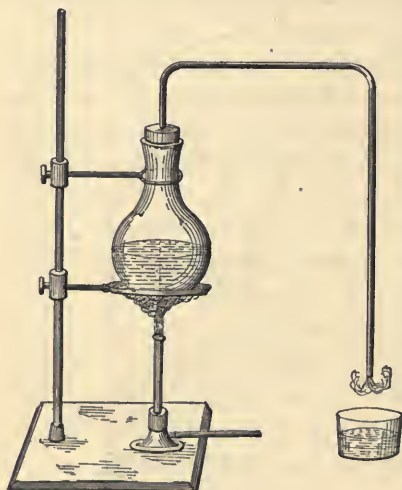

Fig. 17.

applying cold water to the flask. The cold water condenses the vapor and reduces the pressure within the flask so that the boiling begins again. If the air has been thoroughly expelled, the water may be kept boiling till the temperature has fallen to that of the air of the room.

A convenient modification of this experiment consists in fitting into the flask a rubber stopper traversed by a small glass tube, so that the flask is air-tight except through the tube. The tube should be bent twice at right angles in order that the outer end may dip down below the surface of cold water in a beaker (Fig. 17). Boil the water in the flask till the air is expelled, and then dip the open end of the tube under water, at the same time removing the lamp. If the apparatus is air-tight the cold water will rise in the tube as the flask cools, and will at length pass the bend and pour into the flask in a stream.

The cold water condenses the vapor and causes violent ebullition, which will continue, though the water all the time becomes cooler. The only precaution to be observed is to make sure that the air shall enter the tube before the

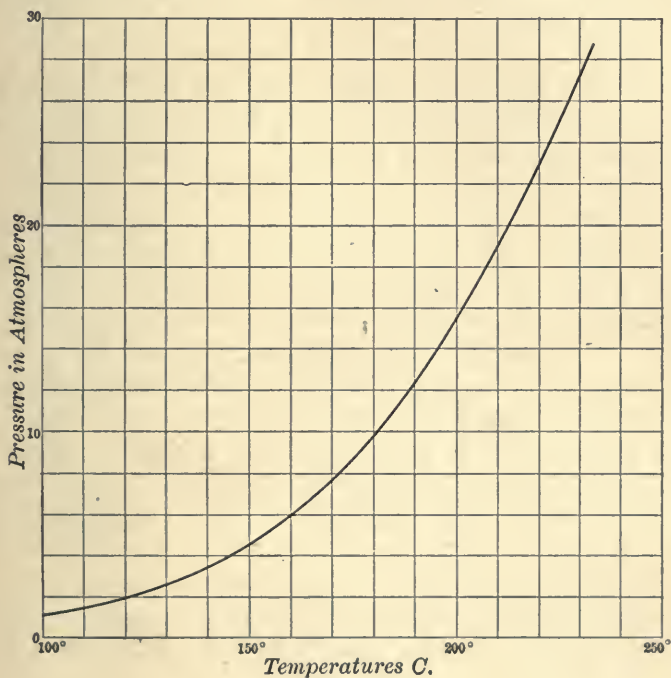

Fig. 18.

flask is filled; otherwise the shock due to the sudden stopping of the stream when the flask is full will break it.

Beyond the normal boiling point the pressure of saturated vapor rises rapidly with the temperature. The rise of temperature from 100° to 180° C. increases the pressure of water vapor from one to nearly ten atmospheres, and an

additional rise of 40° C. raises the pressure to about 23 atmospheres.

The relation between temperature and the vapor pressure of water is represented by the curve of Fig. 18. Above 150° C. this curve rises very rapidly as the temperature increases.

46. The Spheroidal State.—When a drop of water is placed on a clean hot stove it will often take a flattened globular form and roll around with rapid but silent evaporation. This phenomenon is known as the *spheroidal state*. It may be beautifully exhibited by heating a small flat platinum dish red hot over a Bunsen burner, and carefully placing in it a large globule of water by means of a pipette. It will not boil, but will assume the spheroidal state. The globule is not in contact with the hot metal, but rests on a cushion of its own vapor, which escapes rhythmically from its edge and often throws it into beautiful undulations. If the lamp be removed the temperature will fall till a point is reached at which the drop comes into contact with the hot metal, when violent ebullition will take place.

If the drop is not too large, light may be projected through between it and the hot metallic surface, thus demonstrating that the drop is not in contact with the metal.

Boutigny, by placing a small thermometer in the drop of water, found that its temperature remained below the boiling point; and Berger afterwards found that in a large globule the temperature varied from 96° or 98° C. near the bottom to about 90° C. at the upper surface. Budde has shown that under the exhausted receiver of an air-pump the spheroidal state of water may persist at

temperatures as low as 80° or 90° C. The vapor pressure under the drop is then only what is required to support the drop itself, the air pressure having been removed.

Water is not the only substance that assumes the spheroidal form. The temperature of spheroidal sulphur dioxide is low enough to freeze a drop of water placed in it. This may happen in a red-hot crucible because the sulphur dioxide in the spheroidal state is below its boiling point, and this is below the freezing point of water.

Solid carbon dioxide may be touched with the hand or even the tongue without danger if no pressure is applied, because it is kept out of contact by an intervening film of the substance in the gaseous form. Faraday succeeded in freezing mercury in a mixture of ether and solid carbon dioxide contained in a red-hot crucible. The contents of the crucible were cushioned on their vapor in a state analogous to the spheroidal form.

Quite a remarkable example of the spheroidal state, because it takes place at a low temperature, is exhibited by liquid oxygen on water. The liquid oxygen boils gently at about -180° C., and when placed on water it immediately exhibits all the aspects of a globule of water on a hot plate. The water is at a high temperature relative to the oxygen. So much heat, however, is abstracted from the water by the evaporation of the liquid oxygen that the spheroidal globule soon encases itself in an envelope of ice, with only a small blowhole for the escape of the gas.

47. Sublimation. — The usual course from the solid to the gaseous state is through that of a liquid. But a number of solids slowly waste away by evaporation without liquefying. Ice and snow at temperatures below freezing gradually lose in volume by evaporation. So carbon dioxide

snow when exposed in the air wastes away by evaporation, and can be liquefied only with difficulty in an open tube. A solid brick of it will remain unmelted for many hours even in warm weather. It evaporates only so fast as it gets heat to do the work of evaporation.

Other substances, such as camphor and ammonium carbonate, sublime at ordinary temperatures. Iodine, ammonium chloride, and arsenic sublime when heated under atmospheric pressure. But if the pressure is increased arsenic may be fused; and below a certain critical pressure for each, ice, mercuric chloride, and camphor do not melt, but pass directly into the gaseous state.

If by reduction of pressure the boiling point of a liquid is reduced to the fusing point of its solid, then the solid may pass directly into the gaseous state. A solid will, therefore, sublime when the pressure upon it is less than the vapor pressure of its saturated vapor at the temperature of fusion. The vapor pressure of carbon dioxide at its fusing point of -65° C. is three atmospheres; under a lower pressure than three atmospheres it therefore sublimates. If the pressure of mercuric chloride is below 420 mms. it must evaporate without liquefaction. The same is true of iodine at pressures under 90 mms., and of ice under 4.6 mms. of mercury.

48. Latent Heat of Vaporization (P., 304). — The latent heat of vaporization is the quantity of heat required to convert one gramme of the liquid into vapor without change of temperature. The temperature at which the vaporization takes place is often understood to be the boiling point of the liquid under a pressure of one standard atmosphere. The investigations of Regnault on the latent heat of steam enable us to express the latent heat of

vaporization, for water vapor at least, by one formula applicable through a considerable range of temperature. By the *total heat* of steam at any temperature Regnault meant the amount of heat necessary, first, to raise one gramme of water to that temperature without evaporation, and then to convert it wholly into saturated vapor at the same temperature. If L is the latent heat of vaporization, t_1 and t the initial and final temperatures, and s the mean specific heat between these temperatures, then the total number of heat units required to convert a gramme of water at t_1° into saturated vapor at t° is

$$H = L + s(t - t_1).$$

Regnault's experiments were conducted under pressures ranging from 0.22 to 13.625 atmospheres, and from 0° to 230° C.; and between these limits he found that the total heat was represented by the equation

$$H = 606.5 + 0.305t.$$

Taking the mean specific heat of water to be unity and the initial temperature zero, the formula for the latent heat at any temperature t° C. becomes

$$L = H - t = 606.5 - 0.695t.$$

If t is 100° C. the latent heat of steam is therefore 537; that is, 537 calories are required to convert one gramme of water at 100° C into steam at the same temperature.

Taking into account the very small variation in the specific heat of water, the latent heat of steam falls from 606.5 at 0° C. to 536.5 at 100° , and to 464.5 at 200° C.

Prior to Regnault's investigations it was generally admitted on insufficient evidence that the heat required to change a gramme of water at 0° C. into steam was independent of the pressure. If that were true, the sums of the

three pairs of numbers above, representing latent heats and temperatures, should be approximately the same. On the contrary they increase by nearly five per cent for every 100 degrees rise of temperature.

Andrews found the latent heat of evaporation of a few common liquids boiling under atmospheric pressure to be as follows :

Water	536.0
Alcohol	202.4
Ether	90.5
Bromine	45.6

49. **Cold due to Evaporation.** — If the heat required is not supplied from some external source, the evaporation of a liquid will be accompanied by a lowering of its temperature. This fact accounts for the coolness felt when ether, alcohol, or benzine evaporates from the hand. While their latent heat of evaporation is smaller than that of steam, their boiling points are lower and the rapid evaporation absorbs much heat.

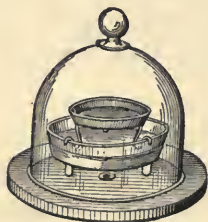

Fig. 19.

In Leslie's experiment a thin flat dish, containing about 10 c.c. of water, is supported by a tripod over a large shallow glass vessel containing strong sulphuric acid, and the whole is placed under the receiver of an air-pump (Fig. 19). The dish should be held in such a manner that it cannot receive heat from below by conduction.

On exhausting the air rapidly the pressure is reduced till the boiling point falls to the temperature of the water. The water then begins to boil briskly; and if the vapor is removed rapidly, both by working the pump and by absorption by the acid, the pressure may be kept low enough to *keep the water boiling till it freezes*. The conditions are

such as to produce rapid evaporation, while the heat required to do the internal work is drawn entirely from the water itself and the thin dish. Not infrequently the bubbles may be frozen before they burst.

Wollaston's cryophorus (Fig. 20) is also designed to show the freezing of water by evaporation. It consists of a bent tube with a bulb at each end. Before it is sealed some water is introduced and boiled to expel all the air from the tube, which is then sealed by fusing the glass.

In performing the experiment the water is all collected in the upper bulb *A*, and the lower one is imbedded in a freezing mixture. The vapor condenses rapidly in *B* and forms at the same rate in *A*. Heat is thus carried by the vapor from *A* to *B*; and as *A* parts with its heat, if none is supplied to it, the temperature of the water in it will fall to the freezing point.

Much lower temperatures may be secured by the rapid evaporation of liquids which boil at a temperature below the boiling point of water. Thus with liquid sulphur dioxide, which boils under atmospheric pressure at -10° C., mercury may be frozen. By the rapid evaporation of liquid carbon dioxide Pietet obtained a temperature of -140° C. Liquid oxygen boiling in air reduces the temperature to -182° C.; and by increasing the rate of evaporation by reducing the pressure, Dewar has reached a temperature of -200° C., or even lower.

This property of heat absorption by liquids that evaporate at a low temperature has been applied to the construction of ice machines. Ammonia is first condensed by pressure and cooling to a liquid with about one-tenth of

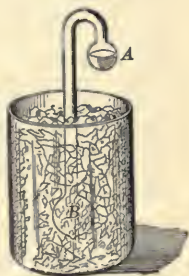

Fig. 20.

its weight of water. It is then evaporated under reduced pressure secured by powerful pumps, and its temperature falls low enough to freeze water in vessels about it or within it. The process is made continuous by returning the ammonia to a condensing chamber cooled with water. It thus passes repeatedly through the same cycle of changes.

50. Relative Humidity. — The atmosphere always contains aqueous vapor, whose pressure is the same as if it alone were present. When its pressure at any temperature of the air equals the saturation pressure for that temperature, it will condense on the surface of bodies, or fall as rain or snow.

The humidity or dampness of the air does not depend alone on the quantity of aqueous vapor present, but on the nearness of the vapor pressure to the saturation point. The saturation pressure at any temperature is the same as that under which water boils at that temperature.

The saturation pressure rises rapidly with the temperature (Appendix, Table III.). Thus the maximum pressure of aqueous vapor at 10° C. is 9.17 mms., while at 21° C. it is 18.5 mms., or a little more than twice as great. Therefore the quantity of aqueous vapor that would saturate the air at the lower temperature would only half saturate it at the higher. The air is said to be damp when it is nearly saturated with vapor. Hence the heating of the atmosphere, while the quantity of aqueous vapor remains unaltered, removes it further from the saturation point and diminishes its dampness. When damp air from outdoors passes through a hot-air furnace it becomes dry air, not because it has lost any aqueous vapor, but because its capacity to take up vapor of water has been increased by the rise of temperature. The requisite saturation pressure

of the aqueous vapor is then much higher; and hence the necessity of adding more vapor of water to bring the air of the rooms nearer to the saturation point. In winter the humidity is usually greater than in summer, not because the quantity of vapor present is greater, but because the temperature is lower and the amount of vapor required to produce saturation is less.

Humidity must therefore be expressed relatively as the ratio of the pressure of the aqueous vapor present at a given temperature to the saturation pressure at the same temperature. This ratio can be measured by determining the actual pressure of the aqueous vapor in the air and comparing it with the maximum pressure at the same temperature obtained from the tables. This is the method applied by means of all dew-point instruments, called hygrometers.

51. The Dew-Point. — If a mass of air containing aqueous vapor be gradually cooled, a temperature will at length be reached at which the vapor will begin to condense. This temperature is called the *dew-point*. Condensation of aqueous vapor may be beautifully illustrated by passing a beam of strong light through a large glass receiver on an air-pump in a darkened room. If the air be only moderately moist, a single stroke of the pump will produce a thick cloud of precipitated vapor with splendid iridescent diffraction effects. The expansion of the air under pressure cools it below the dew-point, and the vapor at once condenses as a visible cloud, consisting of water in a state of fine division. Each minute mote of dust floating in the air serves as a nucleus of condensation and acquires a coating of liquid.

Aitken has shown that the presence of such particles of

dust is necessary to produce condensation of moisture, and that a dustless atmosphere may be supersaturated without the formation of a cloud.

52. Dew. — Any cool body lowers the temperature of the air in contact with it; and if the temperature is by this means reduced to the dew-point, the cool body will become covered with a film of water. Hoar frost is formed when the temperature of deposition is below freezing. If the reduction of temperature to the dew-point occurs in the interior of a mass of air, the condensation results in rain or snow; but if it be in contact with bodies on the earth's surface, the condensation takes the form of dew or frost, according as the temperature of deposition is above or below the freezing point.

The first correct explanation of the conditions attending the formation of dew was given by Wells. He explained the free deposition of dew on cloudless nights by the uncompensated radiation of heat from the earth toward a clear sky. Hence objects which readily lose heat by radiation, particularly if their specific heat be low, receive the largest deposit of dew. On cloudy nights the clouds absorb heat and radiate it back to the earth, or return it by reflection, so that the ground does not cool to the same extent as when the sky is clear.

Another condition favoring a heavy dew is a quiet atmosphere. When the wind blows, the air in contact with any body is replenished so rapidly that it has not time to be chilled to the dew-point.

53. Regnault's Hygrometer. — The hygrometer is an instrument for determining the relative humidity of the atmosphere. The form devised by Regnault is considered superior to all others.

It consists of two thin polished silver thimbles into which are fitted glass tubes open at both ends (Fig. 21). The tube *A* is half filled with sulphuric ether, and is closed with a stopper through which pass a thermometer *t'* and a bent tube *C* extending down nearly to the bottom of the silver thimble. The other tube contains only a thermometer *t*. The two are connected by means of the cross tube supported by the exhaust tube *DE*, which is connected to an aspirator.

To make an observation, the air is drawn in through *C* by the aspirator and bubbles up through the ether, causing it to evaporate rapidly. The temperature of *A* is thus lowered; and when the dew-point is reached, it is indicated by a dimming of the silver tube *A* in comparison with *B*, which remains at the temperature of the atmosphere, as indicated by the thermometer *t*. The agitation of the ether makes it certain that the thermometer *t'* indicates the

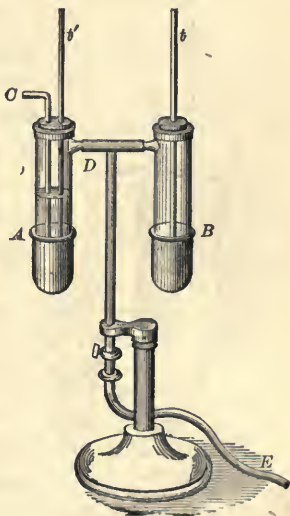

Fig. 21.

correct temperature of *A*. The thermometer *t'* is read as soon as the dimming is apparent. The aspiration is stopped at the same time, and the temperature is again read at the instant when the dew disappears. The observations are made with a telescope at a distance.

The temperature given by *t'* is then the dew-point. The corresponding vapor pressure for both temperatures read on *t'* and *t* may then be taken from the table, and their ratio is the relative humidity. For example, if the

dew-point were 7° and the temperature of the air 20° C., the corresponding saturation pressures are 7.49 and 17.39 mms. respectively. The pressure of the aqueous vapor present would be therefore 7.49, and the maximum possible pressure at 20° C. is 17.39. Hence the relative humidity would be $\frac{7.49}{17.39}$ or 0.431.

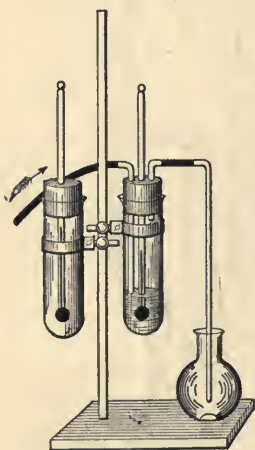

Fig. 22.

Regnault's hygrometer may be roughly imitated by using two test-tubes (Fig. 22) and forcing air through by means of a foot bellows. The escaping vapor may be condensed in a cooled flask further removed from the apparatus than the figure shows.¹

54. Liquefaction of Gases. — Under atmospheric pressure a number of substances are known to us in both the liquid and the gaseous states. Water is liquid below 100° and a vapor at higher temperatures. Alcohol is a liquid below 78° C. and a vapor above. Sulphuric ether is a liquid below 35° C. and a vapor above. If we had no means of obtaining temperatures below freezing, sulphur dioxide would be known to us only as a gas at atmospheric pressure, since it boils at -10° C. In the cold of Arctic regions it would always remain liquid, since under a pressure of one atmosphere it is always liquid below -10° C.

The two facts that some vapors condense to liquids by lowering their temperatures, and that the boiling point of a liquid is raised by pressure, suggest the combined appli-

¹ Wright's *Heat*, p. 201.

cation of cold and pressure to effect the liquefaction of substances which are ordinarily known only in the gaseous form. When the temperature of a substance in the form of a gas is lowered by artificial means, and its boiling point is raised by pressure, the two temperatures approach each other; and if the two simultaneous processes are carried far enough to make the two temperatures coincide, liquefaction ensues.

Faraday was the first to liquefy chlorine, carbon dioxide, cyanogen, and ammonia. His apparatus was of the simplest character, consisting merely of a bent tube (Fig. 23) into which the materials to produce the gas could be placed and hermetically sealed. The pressure employed was the pressure of the gas itself. The shorter limb of the tube was surrounded with a freezing mixture for lowering the temperature.

When crystals of hydrate of chlorine, made by passing chlorine gas into water just above the freezing point, were heated in the longer limb *a*, they decomposed and formed a greenish liquid floating on a clear one. The lighter liquid distilled over and condensed in the shorter arm *b*. When the tube was opened, this condensed liquid was found to be liquid chlorine.

Carbon dioxide was condensed to a liquid in a similar way by heating sodium carbonate in the limb *a*. When cyanide of mercury was placed in *a* and heated, cyanogen was liberated and was liquefied in *b*. To liquefy ammonia advantage was taken of the fact that chloride of silver absorbs about 200 times its volume of this gas. Before sealing either end of the tube, the longer limb was nearly

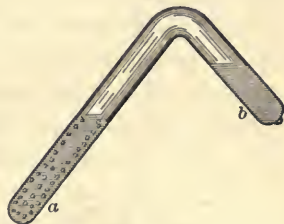

Fig. 23.

filled with dry precipitated silver chloride. Dry ammonia was then passed through the tube, and when the air had been expelled and the chloride was fully charged, both ends were sealed. The end *b* was then placed in a freezing mixture, and a Bunsen flame was carefully applied to *a*. The silver chloride melts at 38° , and begins to part with its ammonia at about 115° C. As the pressure of the liberated ammonia rose, the gas was condensed to a clear, highly refrangible liquid in *b*.

The pressure at which condensation took place was determined by introducing into the experimental tube a smaller one, open at one end, and containing air confined by a small piston of mercury. The pressure was indicated by the extent to which the air in the small tube was compressed. In every case the pressure was observed to increase up to the point where condensation began, and after that it remained constant so long as the condensed liquid was kept at the same temperature. This pressure was that of the saturated vapor at the given temperature.

55. Continuity of the Liquid and Gaseous States (P., 368; M., 119; S., 130). — If water or other liquids be heated in a closed vessel, it is well known that the pressure of the vapor rises very rapidly with the temperature (45). Steam formed at 100° C. has a density of only $\frac{1}{1700}$, while steam formed at 231° C. has a density of $\frac{1}{82}$, the maximum density of water being the unit. Hence not very far above this latter temperature there will be no difference in density between the steam and the water. At such a temperature liquefaction will not be accompanied by condensation, and the usual distinctions between water and steam vanish.

In 1822 Cagniard de la Tour heated water and other

liquids in closed tubes and observed that they appeared to be converted into a gas occupying only from two to four times the volume of the liquid. When a tube, about one-fourth full of water, was slowly heated to 360°C ., the curvature of the surface gradually diminished and finally all demarkation between the liquid and the vapor disappeared. When the gas had cooled a little a thick cloud suddenly made its appearance, and soon the surface of separation between the liquid and the vapor was again visible. De la Tour found the same phenomenon with ether, alcohol, and bisulphide of carbon, but the temperature at which the liquid disappeared was different in each case. This temperature has since been called the *critical temperature*, and the corresponding pressure is the *critical pressure*. The inference is easy that above its critical temperature a gas cannot be liquefied by any pressure, however great.

This conclusion was fully justified by the extended investigations of Dr. Andrews¹ on the conditions of the liquefaction of a gas, and especially of carbon dioxide, for which he found a critical temperature of $30^{\circ}.92\text{C}$. If the pressure on this gas, when above this temperature, be increased to 150 atmospheres, a steady decrease of volume will be observed, but there will be no sudden change of volume at any point. The temperature may then be gradually lowered until the carbon dioxide has reached the temperature of the air. It will then be found to be a liquid. The substance has passed from the gaseous state to the liquid state by imperceptible gradations and without the sudden evolution of heat. Andrews concluded that a gas and a liquid are only widely separated forms of the same condition of matter, and that the passage from

¹ *Phil. Trans.*, 1869, Part 2, p. 575.

one to the other may be made without breach of continuity.

The following are the critical temperatures for several substances :

Ether	196°.2 C.
Acetone	246.1
Alcohol	258.6
Carbon bisulphide	276.1
Water	365

56. Distinction between a Gas and a Vapor. — The discovery of Andrews permits us to distinguish between a gas and a vapor. By a *vapor* is meant a substance in the gaseous state at any temperature below the critical point. A vapor can be reduced to a liquid by pressure alone, and can therefore exist in contact with its own liquid. A *gas*, on the other hand, cannot be liquefied by pressure alone, but only by combined pressure and cooling. A gas is the form which any liquid assumes above its critical temperature. A substance can exist partly in the liquid and partly in the vaporous state in contact only at temperatures below the critical point. Thus, below 30°.92 C. carbon dioxide may exist as a vapor, but above that temperature it cannot be reduced to the liquid state and is a gas.

Below the critical temperature the liquid and the vapor of any substance may be readily distinguished; above that temperature they have not as yet been differentiated by any decisive characteristics. They have apparently the same density and refrangibility, and their molecular attractions are equalized to the extent that there is no surface tension. At the critical temperature the latent heat of vaporization is reduced to zero.

57. Liquefaction of Oxygen and Nitrogen. — On Dec. 24, 1877, two announcements were made to the Paris Academy of Sciences by Cailletet and Pictet that they had liquefied oxygen. It had previously resisted low temperatures and enormous pressures because its low critical temperature had not been reached.

Their plan of operations was to reduce the temperature of carbon dioxide by the rapid evaporation of liquid sulphur dioxide under reduced pressure secured by a vacuum pump; then to carry the lowering of the temperature one step further by the similar rapid evaporation of the cooled liquid carbon dioxide. The gas was carried back in each case and again condensed by a compression pump. The cycle of operations was thus complete.

Fig. 24 illustrates Pictet's apparatus. The oxygen was produced in the heavy iron retort *L*, and toward the close of the decomposition of the potassium chlorate the manometer indicated a pressure of 500 atmospheres in the copper tube *MN*. *H* and *K* are filled with carbon dioxide and *C* and *D* with sulphur dioxide. The two double-acting pumps, *A* and *B*, are coupled together so that *A* exhausts the sulphur dioxide vapor from the cylinder *C*, and *B* compresses it under a pressure of 3 atmospheres in the receiver *D*, where it is cooled by a stream of cold water. From *D* it is returned by the small pipe *d* to *C* as a liquid. Its rapid evaporation in *C* lowers the temperature of the

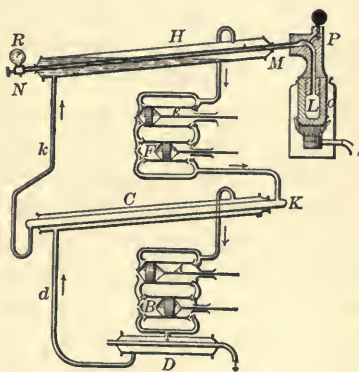

Fig. 24.

liquid to -65 or -70° C. The purpose of this operation is to produce and maintain a sufficient quantity of liquid carbon dioxide in *H* and *K*. The two pumps, *E* and *F*, perform the same offices as *A* and *B*. As fast as *E* exhausts the vapor from *H*, *F* compresses it in *K*, where it condenses under a pressure of from 4 to 7 atmospheres on account of the low temperature produced by the evaporation of the liquid sulphur dioxide. The evaporation of the carbon dioxide reduces the temperature to -130° C. At this stage the pressure of the manometer *R* sinks to 320 atmospheres, indicating that the oxygen begins to liquefy. On opening the stop-cock *N* the liquid issues with great violence as a white jet, and is further cooled by the evaporation and expansion to such an extent that some of it may be obtained in the liquid state.

Professor Dewar has more recently improved on the older process by the employment of nitrous oxide and ethelene in the two successive cycles. The chamber containing the oxygen is protected by a heavy felt covering and is surrounded by two tubular circuits, one traversed by nitrous oxide and the other by ethelene. After the two successive reductions of temperature by the evaporation of first the one liquid and then the other, the cold oxygen under pressure is allowed to rush out through a stop-cock at the bottom of the chamber. It is received in a flask and becomes in part liquid by the further cooling due to the work done in pushing back the atmosphere to make way for itself. It is mixed with some solid carbon dioxide from which it is freed by filtering through an ordinary filter paper. It has a delicate sky-blue color, and its temperature when evaporating under atmospheric pressure is -182° C. Nitrogen is liquefied by the same apparatus. The advantage over the older method is in point of the quantity of gas condensed.

The critical temperature of oxygen is about -112°C. , and its critical pressure 50 atmospheres. The critical temperature of nitrogen is -145°C. ; that of hydrogen is still lower. Thus gases which are condensed only with great difficulty have very low critical temperatures, while substances ordinarily liquid have very high ones.

PROBLEMS.

1. If a mass of aqueous vapor occupies a volume of 500 c.c. under a pressure of 5.9 mms. at 25°C. , find the pressure when the volume has been reduced to 200 c.c.; also the volume at which the vapor becomes saturated at the same temperature (Appendix, Table III.).

2. A vessel is filled with a gas at 15°C. and a pressure of 100 mms. of mercury; find the pressure at 100°C.

3. If 25 gms. of steam at the boiling point be passed into 500 gms. of ice-cold water, to what temperature will the water be raised? The latent heat of steam is 536.5.

4. A block of ice weighing 100 gms. is enveloped in steam at 100°C. , and when the ice is all melted the water has a temperature of 50°C. Assuming no loss of heat, how many gms. of steam have been condensed? The latent heat of water is 79.25.

5. How many calories are required to evaporate 100 gms. of ice-cold water if the evaporation takes place under a pressure of 91.98 mms.? (Appendix, Table III.).

6. How many calories are required to change 100 gms. of ice at -15°C. into steam at 150°C. ? (Art. 48).

CHAPTER VII.

TRANSMISSION OF HEAT.

58. **Three Modes of Transmission.** — The distribution of heat takes place by three distinct modes, which are called conduction, convection, and radiation. By the first method heat is transmitted from particle to particle of a body, or from one body to another in contact with it, by a slow process, which depends upon difference of temperature between contiguous parts, and upon the nature of the conducting substance.

In convection heat is taken up by matter, and is carried with it in its motion. Convection is the transfer of heat from place to place by sensible masses of matter. In this way buildings are heated by the circulation of hot water, and heat is conveyed by hot air. It is chiefly in this way that a uniform temperature in large masses of fluid is established.

Heat is also distributed as radiant energy, which is propagated by a wave-motion in the ether, and by the same physical process as the one involved in the transmission of light. It is by this method that heat and light are conveyed to us from the sun, or from a lamp or a fire. During the transit the heat and light are both radiant energy, or simply radiation. By the first two modes heat is distributed through the agency of matter; while in the third method the ether is the medium of propagation.

59. **Conduction by Solids** (T., 178; S., 268; P., 505; G., 160). — Heat should not be confused with its effects. The melting of iron, the boiling of water, the energetic outrush of steam under pressure, and the leaping aloft of flames are not heat, but the results of converting the motion of heat into mechanical motion. Heat is the energy of molecular motion; and when the molecules of a solid or a liquid are agitated by the motion of heat, they are not free to oscillate without imparting motion to other molecules. The slow transmission of the motion of heat from molecule to molecule of ordinary matter is conduction.

If one end of an iron rod be placed in a fire, the other end will in course of time become hot; the heat travels slowly along the rod from particle to particle, and finally appears at the distant end. This mode of conveyance, by which heat is transmitted from the hotter to the colder

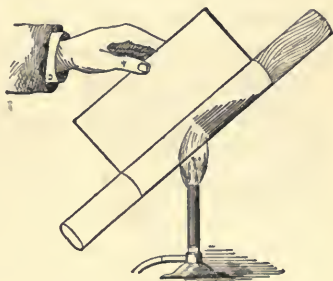

Fig. 25.

parts of a body, or from one body to another of lower temperature, is called conduction. It tends to establish equilibrium of temperatures.

Different substances possess this power of transmitting heat in very different degrees. As a general rule metals are the best conductors, while glass, wood, chalk, fire-clay, gypsum, water, wool, and feathers are very poor conductors. If a cylinder be made one-half of wood and the other half of brass, joined end to end, and if a piece of thin writing-paper be wrapped tightly round it and a flame be applied to the junction (Fig. 25), the paper round

the wood will soon be scorched, while round the brass it will not be injured. The metal conducts away the heat so rapidly that the paper remains below the temperature of ignition; but the sluggishness of the wood in the same process of passing on the heat permits it to accumulate in the paper.

A Norwegian cooking-stove is a box heavily lined with felt, into which fits a metallic dish with a cover. The dish is covered with a felt cushion. The materials to be cooked are placed in the dish with water, which is first boiled for a short time. The dish is then transferred to the box, and is enclosed in it. The conductivity of the felt and the imprisoned air is so poor that in three hours the temperature does not fall more than 10 or 15 degrees C., and the cooking is completed without further application of heat.

Differences in the apparent temperature of bodies are due to their different conductivities. If pieces of metal, marble, wood, and woollen cloth in the same room be touched with the hand, the metal will feel cold, the marble less so, and the woollen cloth least so of all. The sensation of coldness is due to the rapid withdrawal of heat from the hand by the good conducting power of the metal and the marble. In a similar way, if the temperature of these objects were higher than that of the hand, the metal would feel the warmest of the series, because the rate at which heat would flow from it to the hand would be greatest. For this reason we handle hot objects by interposing a poor conductor, like flannel, between them and the hand; and ice is kept from melting by wrapping in woollen cloth or embedding in sawdust.

60. **The Experiment of Ingenhausz.** — One of the earliest methods of comparing the thermal conductivities of

metals was suggested by Franklin and executed by Ingenhauz over 100 years ago. A number of rods of the same length and diameter were fitted into the side of a long trough (Fig. 26). The external portions were thinly coated with wax. Hot water or hot oil was then poured into the trough, and the distances to which the wax was melted on the several bars was measured after their temperatures had attained a permanent state. The relative rates at which the wax is melted at first on the several rods are not the same as their relative conductivities for heat. The rods on which the wax melts most rapidly are not necessarily the ones on which the melting finally proceeds the farthest. If all the rods had the same conductivity, or transmitted the same quantities of heat in unit time, the temperatures of the rods would then be inversely as their densities and specific heats. On prolonged immersion the rods reach a permanent state, and all the heat entering them by conduction leaves them by convection and radiation. The rate of flow must be distinguished from the rate of rise of temperature. The wave of temperature travels faster in bismuth than in iron, but the thermal conductivity of iron is much greater than that of bismuth. While the density of bismuth is somewhat greater than that of iron, its specific heat is only about one-fourth as great; and though the heat reaching it is smaller, its temperature rises more rapidly.

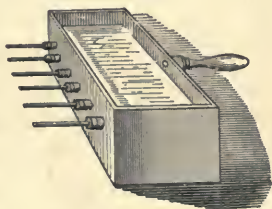

Fig. 26.

The thermal conductivities of the several rods will not be directly proportional to the lengths on which the wax has been melted after prolonged immersion, but to the squares of those lengths, if the rods have the same rates of radiation.

61. Coefficient of Thermal Conductivity (M., 253; P., 509; B., 334; G., 168; S., 271).—The precise meaning of the expression *coefficient of thermal conductivity*, or *specific thermal conductivity*, may be best obtained by considering the transmission of heat through a homogeneous wall with plane parallel faces, one of which is maintained permanently at a temperature t and the other at t' . Let AB and CD (Fig. 27) be the two parallel faces of the wall, and let the line AB represent the temperature

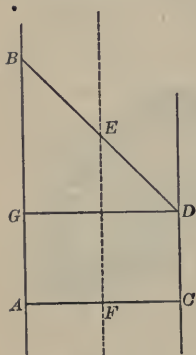

Fig. 27.

of one side and CD that of the other. Since the temperatures are maintained, there will be a permanent state and a uniform flow of heat across the wall in the direction AC . Then if the conducting power of the wall is independent of its temperature between t and t' , the flow of heat will be uniform; and it may be taken as established by experiment that the quantity of heat traversing any imaginary plane EF in the interior of the wall is proportional to the temperature difference $t - t'$. The rate of flow across any section of unit thickness perpendicular to the faces of the wall will therefore be inversely as the thickness of the wall. The rate at which the temperature falls from one side of the wall to the other, or the temperature gradient, will then be uniform, and will be represented in the figure by the slope of the line BD . The total flow of heat through any area S of the wall of unit thickness in time T will be proportional to S and to T . Consequently we have for the quantity H which flows through area S and thickness e in time T

$$H = KS \frac{t - t'}{e} T.$$

The coefficient K is the specific thermal conductivity and depends on the nature of the substance. It may be defined as numerically equal to the quantity of heat which flows in a unit of time through unit area of a plate of unit thickness when unit difference of temperature is maintained between its faces. If the temperature is measured in Centigrade degrees, the dimensions in centimetres, and the time in seconds, the quantity of heat will be in calories.

The practical methods of measuring thermal conductivities are not applied to such a wall, but to the flow of heat along a bar, one end of which is maintained at a constant temperature and the other is at the temperature of the room. The temperature gradient will then be represented by the tangents to a curve obtained by measuring the temperatures at equal distances along the bar. The heat flowing past any cross-section of the bar is all dissipated from the surface beyond the section. The relative conductivities of two bars can be determined by obtaining their temperature gradients; but to measure the absolute conductivity another experiment is necessary for the purpose of finding the rate of cooling, so as to be able to calculate the total quantity of heat traversing any section of the bar.

62. Comparison of Thermal and Electrical Conductivities.—The order of conductivities for the pure metals is the same for heat as for electricity, though the relative values of these conductivities are not the same in the two cases. Both these facts are clearly displayed by the following table, in which the electrical conductivities are those of Lenz and the thermal conductivities those of Wiedemann and Franz :

Names of metals.	Electrical conductivity.	Thermal conductivity.
Silver	100.0	100.0
Copper	73.3	73.6
Gold	58.5	53.2
Brass	21.5	23.6
Tin	22.6	14.5
Iron	13.0	11.9
Lead	10.7	8.5
Platinum	10.3	6.4
Bismuth	1.9	1.8

A further question of much interest is the change of thermal conductivity with increase of temperature. The electrical conductivity of all the metals diminishes with increase of temperature. The same law applies to the thermal conductivity of iron. Matthiessen found that the electrical conductivity of iron decreased 38.26 per cent between 0° and 100° C. Forbes found a thermal decrement for iron between the same limits of temperature of 24.5 per cent in one case and 15.9 in another. But Tait has shown that Forbes overlooked the large change in the specific heat of iron with change of temperature; and when allowance is made for this, the variation in the thermal conductivity obtained by Forbes is reduced to about $\frac{1}{5}$ of the original value.

Professor Tait has shown that the thermal conductivity of iron reaches a minimum somewhere about red-heat; also that copper and lead show a much smaller change with change of temperature than iron does, and that this change is an increment rather than a decrement. Mitchell has recently repeated the measurements with the same bars nickel-plated, so as to preserve the surfaces from oxidation at high temperatures, and he found the temperature coefficient for iron to be positive, as it is for the other metals examined.

63. Conduction in Wood and Crystals (Tyn., 189).

— Tyndall has shown that in thirty-two kinds of wood investigated heat is conducted much better along the fibres than across them. Further, the conductivity perpendicular to the fibres and to the ligneous layers or rings is greater in every case than in a direction tangential to them. The conductivity in the first of these three rectangular directions is from two to four times as great as in the last.

A similar difference of conductivity has been found in the case of laminated rocks, conduction being better along the planes of cleavage than across them. The same statement may be made with regard to bismuth.

If two plates be cut from quartz crystals, one perpendicular to the crystallographic axis or axis of symmetry, and the other parallel to it, and if a minute hole be made through each plate for the admission of a fine wire which can be heated by an electric current, then a film of wax on the plate of crystal will be melted in the form of a circle when the section is at right angles to the axis, but as an ellipse when the section is parallel to the axis (Fig. 28). Quartz and calc spar conduct heat best along the axis and equally in all directions perpendicular to it, while tourmaline conducts best at right angles to the axis.

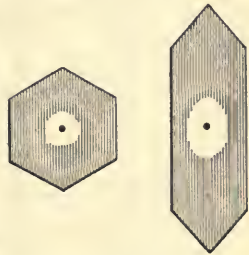

Fig. 28.

64. Conduction by Liquids (P., 557). — If a liquid be heated at the bottom, the expansion by heat diminishes the density and convection currents are set up. The heat distributed by convection masks any distribution by conduction. This difficulty has been overcome in part by

heating at the top. Even then the results are complicated with diffusion and with conduction by the containing vessel.

All liquids except molten metals are poor conductors. The upper strata of water in a test-tube may be boiled for

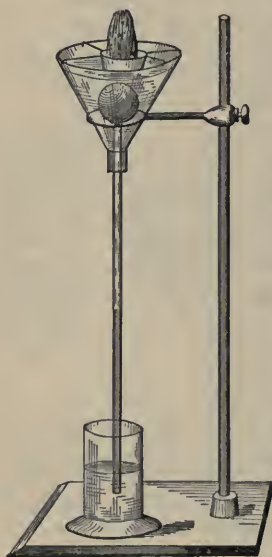

Fig. 29.

some time without melting a lump of ice confined at the bottom of the tube. If a simple air-thermometer have its bulb surrounded by water in a funnel (Fig. 29), and if alcohol be burned in the small porcelain or platinum crucible at the top, it will be found that the thermometer is scarcely affected, even though its bulb be near the surface of the water. So feeble is the flow of heat through liquids that the result is always open to the suspicion that the transport is accomplished by diffusion and convection.

No very concordant results have ever been obtained. The best agreement is perhaps the following, where the conductivity is calculated in C.G.S. units :

Substance.	Temperature.	CONDUCTIVITY.	
		Lundquist.	Weber.
Water	40.8 C.	0.00156	0.00159
Salt solution, density 1.178 . . .	43.9	0.00149	0.00150
Zinc sulphate, " 1.382 . . .	45.3	0.00144	0.00145

65. Conduction by Gases. — The difficulties encountered in measuring the conductivity of liquids are exagger-

ated in the case of gases, so that they become almost insuperable. Many familiar facts, however, go to show that heat is conveyed very imperfectly by gases, except under conditions favorable to convection. The interstices filled with air in bodies made of wool, hair, feathers, fur, and some vegetable fibres, render them poorer conductors than when they have been compressed so as to diminish the air spaces. So some solids which conduct fairly well are very poor conductors when reduced to a powder, because of the interstices containing air.

The dynamical theory of heat leads to the conclusion that the coefficient of conductivity for air is 0.000055, or about $\frac{1}{20000}$ that of copper; also that the coefficient for hydrogen is 7.1 times as great as for air. These conclusions have been approximately verified. But this theory does not demonstrate that gases conduct heat in the same sense as do solids, for it is based on molecular convection, or the energy transferred by the exchange of motion among molecules when they collide.

66. Convection in Liquids. — The distribution of heat by currents of warm water may be illustrated by heating a large beaker filled with water and containing some bits of cochineal. A stream of warm water will be observed ascending along the axis above the burner, and currents of cooler water descending along the sides. Faraday's apparatus to illustrate convection currents is shown in Fig. 30. If the flask and connecting tubes are completely filled with water above the open end of the tube *AB*, the water will begin to circulate up *AB* and down *CD* as soon as heat is applied to the flask by means of a Bunsen burner. To make the circulation visible, the liquid in the flask may be colored red with some aniline dye, and that

in the large open tube at the top may be colored blue. The red liquid will ascend and the blue one descend.

This experiment illustrates the method of heating by hot water. A pipe rises from the top of the boiler to an expansion tank in the upper part of the building. From this tank the water is distributed through the several radiators, and finally again enters the boiler at the bottom. The water loses heat in the radiators and so becomes denser. The heat of the boiler and the loss by radiation and convection at the radiators produce unequal hydrostatic pressures, which give rise to continuous currents so long as the heat is applied.

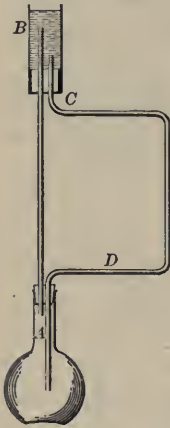

Fig. 30.

The Gulf Stream, even though it may be largely produced by wind, is a convection current on a gigantic scale, and it transports enormous quantities of heat

from the equatorial regions and distributes it over the British Islands and the western part of the continent of Europe. A stream of cold water flows south from Greenland and washes the Atlantic coast of America. Hence the contrast between the climate along the Hudson and the Tiber.

67. Convection in Gases. — Since the mobility of gases is greater than that of liquids, convection currents are all the more easily set up in them. The heated air over a gas flame or a fire rises rapidly, and its place is supplied by the inrush of cold air from the sides. The same action goes on near the sea-coast on a large scale. The ground is heated by the sun, and it in turn heats the

air in contact with it. The heated air rises and the cooler air from the sea flows landward to take its place, giving rise to the sea-breeze. As soon as the sun sets the ground cools rapidly by uncompensated radiation and the air above it becomes cooler than that over the sea. Hence the pressure is outward from the land, and the land-breeze sets in.

Under the vertical rays of a tropical sun the earth and the atmosphere are highly heated; the latter expands, rises, and overflows toward either hemisphere. The denser air flows in from north and south to replace the ascending mass. This inflow has the velocity toward the east of those parts of the earth's surface from which it comes. This is less than the velocity at the equator. Hence, the currents of air approaching the equatorial belt lag behind the rotating sphere and arrive as north-east and south-east Trade Winds.

A belt of calms advances a few degrees toward the north in summer, while in winter it recedes somewhat toward the south, following the declination of the sun. The overflow north and south veers toward the east by reason of its greater eastern velocity than the successive points at which it arrives. It therefore constitutes the southwest and the northwest upper trades, which gradually sink toward the earth.

The principle of convection explains ventilation. The heated air in a chimney rises because it is warmer than the air without. The external pressure is therefore only partly counterbalanced by that of the air in the flue. If

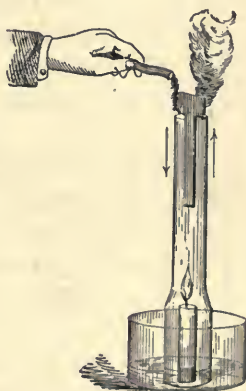

Fig. 31.

the chimney happens to be colder than the external air, there is a downdraft, or the chimney smokes.

Place a lighted candle at the bottom of a lamp chimney. Ingress of air at the bottom may be prevented by pouring a little water in the outer dish (Fig. 31). The flame soon goes out for lack of air. If the T-shaped partition be now inserted in the chimney and the candle be relighted, it will continue to burn; and if a piece of smouldering brown paper be held over the tube, the smoke will descend on



Fig. 32.

one side of the partition and ascend on the other, a true convection current supplying oxygen to the candle and carrying off the products of combustion.

68. Convection by Hydrogen.—The rapid distribution of heat by hydrogen was the subject of a celebrated experiment by Dr. Andrews. A thin platinum wire, which could be heated by an electric current, was stretched along the axis of a tube. The corks at the ends were provided with an inlet and an outlet tube (Fig. 32.) When the tube was exhausted of air, the current was adjusted so as to heat the wire to vivid brightness without fusing it. The introduction of air diminished the brightness of the wire somewhat; but when the tube was filled with hydrogen the wire was scarcely red hot. In a vacuum the wire loses heat almost entirely by radiation, but in an atmosphere of hydrogen, even though it be very attenuated, the light and rapidly moving molecules carry

frequent cargoes of heat from the wire to the cooler walls of the tube.

The slow rate of cooling of a heated platinum wire in an exhausted globe, as compared with its rate in the open air, illustrates the loss of heat by convection currents. The wire remains visible for a sensibly longer time in a vacuum than in the air after the heating current of electricity is cut off.

The incandescent lamp is ordinarily made with a high vacuum to avoid the loss of heat by the convective process. For this reason an inert gas like nitrogen cannot be used in the bulb, because the energy is then rapidly conveyed from the filament to the envelope, and heats it at the expense of the brightness of the filament. The glass globe heats to a still higher temperature when the carbon filament is enclosed in an atmosphere of hydrogen. Hydrocarbon gases have sometimes been used in glow lamps because of their reparative function when decomposed by heat, since they deposit carbon on the filament as an offset to the waste going on in the normal operation of the lamp.

PROBLEMS.

1. How many calories of heat will be conducted in one hour through an iron plate one metre square and 0.3 cm. thick if the two sides are kept at the temperatures 0° and 60° C., the coefficient of conductivity of iron being 0.175?

2. One side of a brass plate 1 cm. thick and 100 sq. cms. in area is kept in contact with boiling water on one side and with melting ice on the other; it was found that 22.9 kilos. of ice were melted in 10 minutes. Find the coefficient of conductivity of brass in C.G.S. units.

3. How much water will be evaporated per hour at 100° C. from a boiler 0.5 cms. thick and with a heating surface of 1,000 sq. cms., its outer surface being kept at 150° C.?

4. A plate of glass 2 cms. thick and 3×4 metres in area separates two rooms which are kept at 15° and 50° C. respectively. If the coefficient of conductivity of the glass is 0.015, find the quantity of heat given off per minute by the glass.

CHAPTER VIII.

RADIATION AND ABSORPTION.

69. *Appliances for the Study of Radiation.* — The physical identity of radiant heat and light has already been dwelt upon in an earlier chapter (6). The transmission of heat-energy through a medium without affecting it is an operation identical with that of the transmission of light; but since radiations of longer wave-length than about 7,600 tenth-metres (I., 217) do not excite vision, the study of radiations of long wave-length falls within the domain of Heat; for to produce any effect these radiations must first be absorbed, and by this process energy is imparted to the substance on which they fall. The most general effect of this absorption is heat.

In light the effects are directly visible, but we need some means of recognizing the presence of those radiations which do not excite vision.

Since most substances exhibit the same selective preference in the absorption of radiation generally, as they do for those wave-lengths which lie within the visible spectrum and give rise to color, it becomes of prime importance in studying heat effects to find some substance which will absorb all radiations alike. Such a substance is lampblack.

A thermometer with a blackened bulb is sufficient for many purposes in the study of radiant heat. A still more sensitive receiving apparatus is the thermopile, which will

be fully described later. It will be sufficient to explain here that if a junction of two dissimilar metals, such as antimony and bismuth, be heated, an electromotive force will be generated, which will give rise to a current through a closed circuit. If a number of thin bars of the two metals, alternating with each other, be joined together and arranged so that the alternate junctions all fall on one side of a cube, as in Fig. 33, then when this face is heated a current will flow through the circuit and it will be indicated by an appropriate galvanometer. If the same face be cooled, a current will flow in the reverse direction.

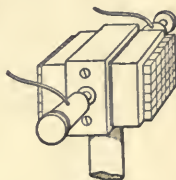

Fig. 33.

Boys' radiomicrometer consists of a single thermal junction and a galvanometer combined in one instrument.¹ It has been made so sensitive as to indicate readily the heat radiated from a candle on the opposite side of a large hall. In both instruments the receptive portion must be covered with lampblack.

70. Invisible Radiation reflected like Light. — The essential identity of radiant heat and light becomes evident when it is demonstrated that the various phenomena of optics may be reproduced by those radiations which do not directly affect the eye. Aside from the simplest observation that radiant heat like light travels in straight lines through a uniform medium, the most obvious analogy between the two is found in their common obedience to the law of reflection.

Let two large concave mirrors, usually of brass or copper, be placed several metres apart and facing each

¹ Preston's *Theory of Heat*, p. 497.

other, as in Fig. 34. If a candle be placed at the principal focus of one mirror, the two may be adjusted in position, and the image of the candle may be found at the focus of the second one by means of a small piece of white paper. Then if the candle be replaced by a heated iron ball, and the blackened face of the thermopile be placed where the image was found, the galvanometer will at once show that the thermopile is heated. The largest effect will be obtained when the face of the pile is exactly at the focus previously found. The reflection of the non-luminous rays from the two mirrors takes place in the same manner

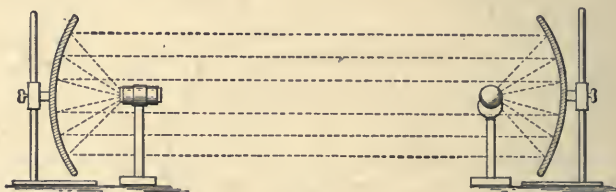

Fig. 34.

as that of the luminous rays, for they converge to the same point. If the ball be heated to a dull red, the convergence of the heat at the focus of the mirror may be readily ascertained by the hand. The thermopile will detect it when the ball has cooled to such an extent that it may be held in the fingers.

In connection with this apparatus, attention may be called to the fact that if the ball be replaced by a piece of ice the current through the galvanometer will show that the thermopile is cooled. The significance of this fact will appear later.

It has been demonstrated by experiment that —

(1) Radiant heat is reflected copiously from metals in the same manner as light.

(2) When radiant heat is reflected, either from glass or polished metals, the variation of the intensity with the angle of incidence follows the same law as that applying to light; that is, the percentage of the incident radiation which is reflected increases with the angle of incidence. Thus glass, which at normal incidence reflects only 4.3 per cent, at 88° reflects 81.9 per cent of the incident radiation.

(3) Heat is diffusely reflected in the same manner as light. Just as diffusion is selective for light, red flannel for example appearing brilliantly red in the less refrangible end of the spectrum and black in the green (I., 219), so, as Melloni showed, diffusion is selective also for the non-luminous radiations.

71. **The Law of Inverse Squares.** — Melloni was the first to perform an ingenious experiment to demonstrate that the thermal radiation received by any small area varies inversely as the square of its distance from the source. *BC* (Fig. 35) is a shallow box filled with hot water and having its anterior face covered with lampblack.

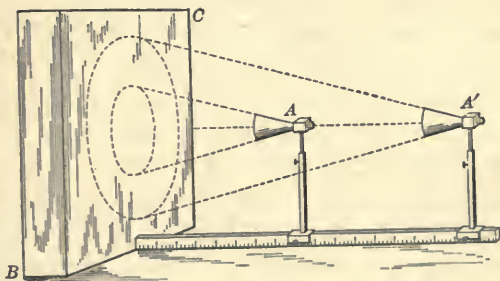

Fig. 35.

A is a thermopile with a converging cone to concentrate the radiations on its blackened face. Let it be placed in the position *A*, and let the resulting deflection of the galvanometer be noted; then let the thermopile be moved to double the distance from the box at *A'*. The

galvanometer will indicate the same current as before. The radiating surfaces in the two cases are the bases of the dotted cones. Their linear dimensions are as one to two and their areas as one to four. Since the radiation from a four-fold area produces the same effect at twice the distance, the intensity of the radiation received from any small area must vary inversely as the square of the distance. Since the radiating surface increases as the square of the distance, the intensity of the radiation must diminish as the inverse square of the distance. In the same way a uniformly red-hot surface, viewed by the eye through a tube, appears equally bright at all distances, so long as the surface fills the field of view through the tube.

72. Refraction of Radiant Heat (S., 196). — Herschel made the observation that there are dark heat-radiations in the solar spectrum beyond the red end. Their existence there demonstrates that they are emitted along with radiations of shorter wave-length from a source of high temperature like the sun.

After Melloni had discovered that rock salt transmits all kinds of non-luminous radiations with nearly equal facility, while every other substance absorbs them with avidity, he made use of rock-salt lenses and prisms to demonstrate that the radiation from a non-luminous source is capable of refraction. Glass is as opaque to radiation from a non-luminous source as black glass is to the visual rays. But by employing rock salt Melloni knew that the radiation which he was studying was not stopped by the substance of his prisms and lenses. He was thus able to demonstrate that the radiation from a body at low temperatures may be concentrated at the focus of a lens, and may be refracted by a prism. The receiving apparatus

employed in this investigation was a sensitive thermopile, and the source for obscure rays a blackened copper cube filled with water at 100° C.

Forbes subsequently measured the index of refraction from several sources of varying temperature, and demonstrated that the refrangibility for non-luminous rays is less than for luminous rays. The following are the indices of refraction of rock salt for the several sources:

Mean luminous rays	1.602
Heat from incandescent platinum	1.572
Heat from a lamp without a chimney	1.571
Heat from brass at 370° C.	1.568

The refrangibility therefore decreases with the temperature of the source, and the obscure rays are of smaller refrangibility or longer wave-length than the visual rays.

73. Polarization of Heat (S., 200). — Another evidence of the fundamental identity of radiant heat and light is derived from experiments in polarization. Malus and Berard first showed by reflection experiments, similar to those applied to light (I., 228), that the radiant heat of the sun is capable of polarization. Later Forbes showed that whether the source were a lamp or brass heated below luminosity, the radiation is polarized by transmission through tourmaline, and suffers extinction in the same manner as light when the two plates are crossed (I., 224). By the use of mica plates split by heat and acting like a bundle of plates, he demonstrated that dark heat is polarized by reflection and refraction. Mica in this state is nearly opaque to light, but transmits non-luminous radiations quite freely. When two such plates are placed at the proper angle with the beam, and with the one turned

90° around the beam with respect to the other, they were found to stop a large portion of the incident heat, including the radiation from a blackened vessel containing boiling water.

From such facts as the foregoing it can be affirmed that we have the most complete experimental evidence that radiant heat and light are transmitted through the ether by the same undulatory disturbance, whatever may be its mechanism. Not only are Fraunhofer (absorption) lines found in the visible solar spectrum, but the thermopile and the bolometer¹ reveal their presence in the infra-red end. Rowland's photographs of the solar spectrum, extending beyond the visible limit at the violet end, exhibit no distinctions which mark the boundaries of the visible portion. That limit is imposed by the structure and physiology of the eye. Langley has measured the energy of the radiation from his bolometer at -2° C. to a block of ice at -20° C. The analogy between radiant heat and light does not need the support of any additional evidence.

74. Heat the Measure of Radiant Energy (M., 238).

—From all the facts at command we have reached the conclusion that radiant heat, like light, is propagated as a transverse undulation in the ether as a medium. If by some means, such as transmission through a prism, the radiations have been separated according to wave-length, and if from them we select for examination those that will excite vision when received into the eye, or initiate chemical changes in the appropriate substance, or finally

¹ The bolometer, invented by Professor S. P. Langley, is an instrument whose operation depends on the change of electrical resistance with temperature. A thin strip or grating of blackened metallic foil composes one arm of a Wheatstone's bridge. When it is exposed to radiation it is heated, and the heat-energy can be measured by means of the deflection of a galvanometer.

produce heat when absorbed by lampblack, then it will be found that, as the intensity is changed, all of these effects rise and fall together. It is therefore the same ethereal disturbance which produces visual, actinic, or thermal effects, according to the constitution of the absorbent which determines its function.

But while these radiations produce three distinct effects, only one of them can be taken as the measure of the energy transmitted, viz., the heat generated when they are completely absorbed. This is true, not only because the visual or chemical impressions produced by different kinds of radiations are not proportional to the energy involved, but because they are specific effects depending on wave-length. While the physiological effect of light of a definite wave-length bears some relation to the energy of the vibrations, yet neither in vision nor in photography can the results be taken in any scientific sense as a measure of the energy of the cause. Chemical changes are doubtless initiated by light because of the co-vibrational action, whereby the unstable molecular equilibrium of certain chemical compounds is broken up and more stable combinations follow as a result of molecular forces. But the energy that topples over a brick at the top of a building and initiates the downfall is not measured by the effect produced by the brick in falling under the operation of gravity.

On the other hand, when any radiation is completely absorbed by lampblack, its energy has simply undergone a transformation from the energy of ethereal vibrations into the energy of molecular agitation, which is called heat. An energy spectrum of the radiations from any source may therefore be mapped out by means of appropriate apparatus. This has been done by Professor Langley, not

only for the solar spectrum, but for the spectra of radiations from blackened copper at several low temperatures. One important conclusion reached by him is that when the energy and wave-lengths are plotted as coördinates, the maximum energy ordinate moves toward the shorter wave-lengths as the temperature of the source rises.

75. **Absorption of Radiation** (S., 198; P., 464).—We are familiar with what occurs when luminous radiations are incident on a body. In general, one part is reflected, another is transmitted, and a third is absorbed. Thus, a piece of red glass reflects a portion of the incident beam, transmits only light belonging near the red end of the spectrum, and absorbs the rest, converting its energy into heat. If the transmission is reduced to zero, the body is opaque; if the surface is composed of lampblack, the reflected light is sensibly zero and the entire incident beam is absorbed. The absorption which rejects the red only is called selective absorption, while that of lampblack is general. Absorption may, however, be general as contrasted with selective, without being total.

This division of incident radiation, either by general or by selective absorption, is not peculiar to those radiations that affect the eye. Bodies which transmit radiant heat are said to be *diathermanous*, while those which absorb it are called *athermanous*. A body transparent to light is not therefore transparent also to non-luminous radiations. Common glass is transparent even to vibrations somewhat beyond the violet of the solar spectrum; but it is very athermanous to long heat-waves. Melloni showed that a sheet of glass 2.6 mms. thick stops all the radiation from blackened copper at 100° C., and all but 6 per cent from copper at 390° C. If a sheet of glass be held between the

heated ball and the mirror in the experiment of Fig. 34, little or no heat will be detected at the focus of the distant mirror. All glass exhibits selective absorption, but colored glass has its range of absorption extended to some portions of the visible spectrum.

Hard rubber in thin sheets is opaque to light, but quite transparent to long heat-waves. Carbon disulphide transmits in almost equal degree the luminous and the non-luminous rays; but if iodine be dissolved in it, more and more light will be cut off as iodine is added, till at length the solution becomes opaque. But heat is still freely transmitted, or the solution is diathermanous. Tyndall demonstrated that, by enclosing it in a hollow lens with rock-salt faces, it transmits enough heat from an electric arc light to raise platinum to incandescence at the focus. These facts lead to the conclusion that selective absorption extends throughout the entire spectrum, visible and invisible.

76. Two Characteristics of Absorption. — The radiation from a hot body which has passed through one plate is more easily able to pass through another of the same substance. This is precisely similar to the fact that the light which colored glass transmits is almost wholly transmitted by a second piece of glass of the same kind. Melloni found that a plate of alum which transmitted only 9 per cent of the radiation from a naked lamp transmitted 90 per cent of the heat coming through a plate of the same material. A second plate of selenite transmits 91 per cent of the radiation transmitted by a first one. It is possible to find athermanous combinations, just as red and green glass together are opaque to light. Thus alum and black mica form a nearly athermanous combination.

The hypothesis to account for this fact applies the principle of sympathetic vibration in Sound. Any resonant body absorbs those vibrations which correspond with its own vibration-rate (I., 151). So the molecules of every substance are assumed to have vibration-rates of their own; and when the disturbances transmitted to them by the associated ether have corresponding rates, the vibrations are taken up by the body. Periodic disturbances of other frequencies are rejected and pass through.

The second important general fact is that most substances, including those transparent to light, are nearly opaque to radiations of long wave-length. It is much easier to find transparent substances than diathermanous ones. Rock salt is diathermanous in a remarkable degree, but Balfour Stewart has shown that it absorbs those vibrations of great wave-length which it radiates when heated; and Forbes has shown that the general index of refraction of a beam of radiant heat is increased by transmission, indicating that the percentage loss is the greater on the less refrangible side. This rule is not without exceptions. The solution of iodine in carbon disulphide is a case in point; and a piece of smoked rock salt stops most of the light, but transmits heat.

77. Diathermancy of Liquids.—The diathermancy of liquids was investigated by Melloni by enclosing them in a glass cell, while the source of heat was an Argand lamp with a glass chimney. For such radiations water is exceedingly opaque. The solution of a salt rather increases its diathermancy. A solution of alum is slightly more diathermanous than pure water. This conclusion is contrary to the common opinion, but it has lately been confirmed by Shelford Bidwell. The old notion that a

strong solution of alum is more athermanous than water was probably derived from the fact that a plate of alum is highly athermanous; but it is less so than rock candy or ice, though the thermopile will readily reveal the heat transmitted through a block of the latter substance. Water and ice appear to be pervious and impervious to the same radiations, so that one may be used as a sieve to secure radiations that will pass through the other.

In Tyndall's experiments the liquids were contained in a cell with rock-salt faces, and the source of heat was an incandescent platinum spiral. The results are in substantial agreement with those of Melloni.

78. *Diathermancy of Gases* (P., 470; Tyn., 274).¹—Experiments on the most elaborate scale by Tyndall failed to show any appreciable absorption of heat by dry air. They were conducted by passing radiant heat through a tube filled with pure air and closed at both ends with plates of rock salt.

The old opinion that other gases and vapors are equally diathermanous proved not to be true. Ammonia, olefiant gas, sulphur dioxide, marsh gas, hydrogen disulphide, and nitrous oxide were shown to absorb very perceptible portions of the thermal flux through the tube.

When the temperature of the source is raised, the percentage of absorption diminishes. The diathermancy of volatile liquids and that of their vapors appear to follow nearly the same relative order. In the main, the molecules retain their power as absorbers independently of the state of aggregation. Since ice and water are very athermanous, aqueous vapor may be expected to show marked absorption of radiant heat. Tyndall's experiments lead to the con-

¹ Tyndall's *Contributions to Molecular Physics in the Domain of Radiant Heat*.

clusion that this anticipation in regard to the opacity of aqueous vapor is justified. But it has been contested by Magnus, who found the effect of dry air to be precisely the same as that of moist air, and "that the water present in the atmosphere at 16° C. exercises no perceptible influence on the radiation."

79. *Prevost's Theory of Exchanges* (M., 240; S., 204). — If a warm body, such as a thermometer, be hung within an enclosure cooler than itself, it will lose heat by radiation and convection till thermal equilibrium ensues. Even in a vacuum the equilibrium will be attained by radiation alone. The question arises, Does all radiation cease when the body and the enclosure are at the same temperature, and does it radiate no heat when surrounded by bodies warmer than itself? If a cold body were introduced into the enclosure it would immediately begin to receive heat by radiation; but it can have no direct effect on the radiation of other bodies within the enclosure. Prevost therefore came to the conclusion that the radiation continues all the time, and that its intensity has no relation to the temperature of other bodies, but is a function of the nature of its surface and of its temperature. If the body radiates more than it receives, its temperature falls; but if it receives more than it radiates, its temperature rises. "If two bodies have the same temperature, the radiation emitted by the first and absorbed by the second is equal in amount to the radiation emitted by the second and absorbed by the first during the same time."

Prevost was probably led to this theory of exchanges, or of a movable equilibrium of temperature, by the experiment described in Art. 70, where the piece of ice at the focus of one mirror caused a fall of temperature of the

thermopile at the focus of the other. Since cold is only the absence of heat, it is inadmissible to suppose that cold is radiated. Such a supposition is not only unscientific, but unnecessary. The thermopile radiates toward the ice exactly as it radiates toward the hot ball, but it receives from the ice less than it expends by radiation, and its temperature therefore falls.

The two processes of radiation and absorption are then going on simultaneously and continuously, and a stationary temperature is maintained only so long as the emission and the absorption are exactly equal to each other. Prevost's theory has been greatly extended at various times by Leslie, Stewart, Kirchhoff, and others. It has not only been verified by subsequent investigations, but it has suggested new theories which have also received experimental verification. It is necessary to prepare the way before proceeding to the extension of Prevost's theory, by a brief account of Leslie's experiment on radiation and by some definitions.

80. Leslie's Experiment. — Leslie examined the radiating power of different surfaces by means of a hollow metal cube; one side was polished, a second was roughened, a third was covered with varnish or with white lead, and the fourth with lampblack. When the cube was filled with boiling water the relative radiations from the several surfaces were compared; the roughened surface was found to radiate more freely than the polished one, while it was surpassed by the third and fourth, which exhibited nearly equal radiating power.

In a similar way Leslie investigated the reflection of heat from surfaces of different character, and found that the best reflectors are the poorest radiators. Taking a

polished brass surface as a standard of comparison, he found the following relative reflecting powers :

Brass	100	Lead	60
Silver	90	Amalgamated tin	10
Tin	80	Glass	10
Steel	70	Lampblack	0

The absolute reflecting power, that is, the percentage of incident radiation which is reflected, has since been measured for several substances, with the following results :

Silver	0.97	Steel	0.82
Gold	0.95	Zinc	0.81
Brass	0.93	Iron	0.77
Platinum	0.83	Cast iron	0.74

81. Definitions.— Lampblack is taken as the standard with which to compare the absorption and radiation of other surfaces because it reflects no sensible part of the radiation incident on it, and because it radiates more freely than any other substance. Emissive power and absorbing power may then be defined with respect to lampblack as follows :

The emissive power, or emissivity, of a surface is the ratio of the quantity of radiation which it emits to the quantity which a lampblack surface of equal area emits at the same temperature in the same time.

The absorbing power of a surface is the ratio of the quantity of radiation which it absorbs to the amount which a lampblack surface of equal area would absorb in the same time.

Since a lampblack surface is assumed to absorb all the radiation which falls on it, the absorbing power of a body under given conditions may be more simply defined as the

fraction of the whole incident radiation which it absorbs under those conditions.

These two quantities are connected by the simple relation that the emissivity and absorbing power of any surface at a given temperature are equal.

Tyndall found the following values by coating the faces of a Leslie cube with powders of the different materials :

Substance.	Absorbing power.	Emissive power.
Rock salt	0.319	0.307
Fluor spar	0.577	0.589
Red oxide of lead	0.741	0.707
Oxide of cobalt	0.732	0.752
Sulphate of iron	0.824	0.808

These numbers do not differ greatly, considering the difficulty of an exact numerical determination.

A simple experiment demonstrates the equality between the absorbing power and the emissivity. Let *AB* and *CD* (Fig. 36) be two tin plates with the front of one polished and that of the other covered with lampblack. To the back of each is soldered a piece of bismuth *E* to form a thermo-

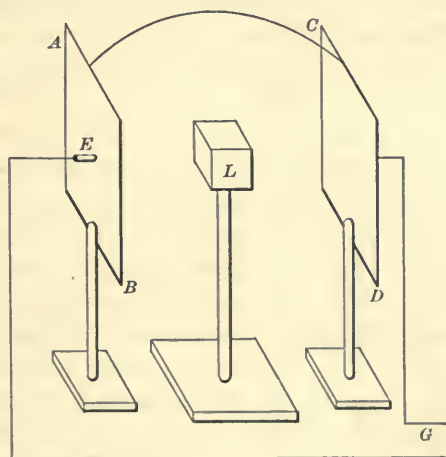

Fig. 36.

electric couple. The polished and lampblack sides are arranged to face each other, and between them is placed a Leslie cube *L*. The

side of the cube facing the polished plate is covered with lampblack, while the side facing the lampblack is polished. The wires at G lead to a galvanometer. If one of the thermoelectric junctions be heated more than the other, the differential electromotive force generated will produce a current.

If now the cube be filled with boiling water and be placed exactly midway between the plates, the galvanometer will show no current. Hence the amount of heat absorbed by the two plates must be the same. The blackened face of the cube radiates more than the polished face; but the polished plate absorbs only a fraction of the incident radiation, while the blackened one absorbs all the radiation coming from the polished face of the cube presented to it. It follows that the fraction which the polished plate absorbs is just equal to the fraction which the polished face radiates, both compared with lampblack, or the emissive and absorbing powers of the polished plate are the same.

82. Extension of Prevost's Theory (M., 243; S., 207; P., 442).— The theory of exchanges may be shown to

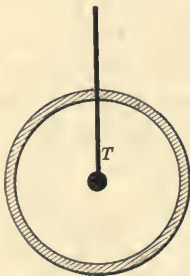

Fig. 37.

be applicable to every distinction in the quality of the radiation as well as to the total amount of it. By quality of radiation is meant any specific difference, such as wave-length or plane of polarization, which may affect absorption.

Imagine a thermometer T suspended in a blackened chamber with which it is in thermal equilibrium (Fig. 37). It will be in equilibrium with the enclosure and with everything in it in whatever part of the chamber it

may be placed. Suppose its bulb to be covered with lamp-black; it then radiates and absorbs a maximum quantity of heat, and its radiation equals its absorption because its temperature remains constant. Another thermometer, whose bulb is silvered, will indicate the same temperature; but it absorbs only about three per cent of the incident radiation; therefore to maintain its temperature unchanged, it must radiate only the same small per cent as compared with the blackened one. The same relation will hold true for another thermometer covered with any other substance.

If any part of the walls of the enclosure exhibits some selective absorbing power, then the stream of radiation from this part of the enclosure must remain unaltered because the blackened thermometer maintains a constant temperature; therefore the wall must radiate specifically what it absorbs, both in quantity and quality, so that the emitted radiation added to the reflected radiation shall equal lampblack radiation.

Suppose further that a thin plate of some substance, which transmits radiations of certain definite wave-lengths only, be suspended within the enclosure. This plate will radiate just as much as it absorbs because its temperature remains constant. But since the blackened thermometer continues to receive the same radiation in amount and quality from the direction of the plate, the latter must emit on one side exactly the same quality of radiation which it absorbs on the other, so that the transmitted plus the emitted radiation shall remain equal both in quantity and quality to the stream of radiant heat from that direction before the introduction of the plate.

It may thus be seen that the stream of radiation in such an enclosure must be the same throughout in quantity and

within so as to be supported at the centre of the bomb. After removal from the fire the apparatus is placed in the dark. The light received by the eye, viewing the tourmaline through the hole, then comes only from the tourmaline itself, since no light enters the opposite hole and none is transmitted from the iron. When examined by means of a polariscope, this light is found to be polarized in a plane at right angles to the light which the crystal transmits; or, in other words, the light emitted is polarized in the same plane as the light absorbed.

84. **Law of Cooling** (S., 230; M., 246). — Newton's law of cooling is that the rate of cooling of a heated body is proportional to its excess of temperature over that of the surrounding medium. This law holds only approximately for small differences of temperature and fails entirely when the excess is large.

The most elaborate investigations on this subject are those of Dulong and Petit. They were conducted by the use of a large thermometer within a spherical shell of copper, blackened on the inside and exhausted of air.

The first conclusion reached was that, for a given excess of temperature of the thermometer above that of the enclosure, the rate of cooling in a vacuum increases in a geometrical series when the temperature of the enclosure increases in an arithmetical series, and the ratio of the geometrical series is the same whatever be the excess of temperature. Thus, if the excess of temperature be 200° C., the rate of cooling for the enclosure at 0° was 7.40; at 20° , 8.58; at 40° , 10.01; at 60° , 11.64; at 80° , 13.45. The average ratio of these successive numbers, and of others found by the same experimenters, was 1.165, while the temperature of the enclosure increased by equal steps of 20° C.

The formula of radiation obtained by Dulong and Petit, which does not express the facts with great exactness, is

$$R = ma^t + k,$$

where R is the quantity of heat radiated in unit time from unit area of the surface at the temperature t , m is a constant depending on the substance and the nature of the surface, a is a constant equal to 1.0077 for the Centigrade scale, and k is a constant not yet determined.

From an examination of the data of Dulong and Petit, Stefan concluded that the radiation emitted is proportional to the fourth power of the absolute temperature, or

$$R = n (273 + t)^4,$$

where n is a constant and t is the temperature of the radiating body. A similar expression holds for the rate of cooling if the specific heat of mercury be assumed to be constant. If t is the temperature of the enclosure and t' the excess of temperature of the thermometer, then the rate of cooling will be the difference between the radiation of the thermometer and the counter radiation of the walls of the enclosure, and we may write :

$$\text{Rate of cooling} = n (273 + t + t')^4 - n (273 + t)^4.$$

This formula has been deduced theoretically by Boltzmann, and is in better agreement with more recent experiments than that of Dulong and Petit.

The rate of convective cooling in a gas was expressed by Dulong and Petit as follows :

$$r = ap^bt^{1.223},$$

where a and b are constants for any given gas, p is the pressure, and t the excess of temperature of the cooling body over the gas. This rate is independent of the nature and surface of the body, but varies with its form and dimensions.

within so as to be supported at the centre of the bomb. After removal from the fire the apparatus is placed in the dark. The light received by the eye, viewing the tourmaline through the hole, then comes only from the tourmaline itself, since no light enters the opposite hole and none is transmitted from the iron. When examined by means of a polariscope, this light is found to be polarized in a plane at right angles to the light which the crystal transmits; or, in other words, the light emitted is polarized in the same plane as the light absorbed.

84. **Law of Cooling** (S., 230; M., 246). — Newton's law of cooling is that the rate of cooling of a heated body is proportional to its excess of temperature over that of the surrounding medium. This law holds only approximately for small differences of temperature and fails entirely when the excess is large.

The most elaborate investigations on this subject are those of Dulong and Petit. They were conducted by the use of a large thermometer within a spherical shell of copper, blackened on the inside and exhausted of air.

The first conclusion reached was that, for a given excess of temperature of the thermometer above that of the enclosure, the rate of cooling in a vacuum increases in a geometrical series when the temperature of the enclosure increases in an arithmetical series, and the ratio of the geometrical series is the same whatever be the excess of temperature. Thus, if the excess of temperature be 200° C., the rate of cooling for the enclosure at 0° was 7.40; at 20° , 8.58; at 40° , 10.01; at 60° , 11.64; at 80° , 13.45. The average ratio of these successive numbers, and of others found by the same experimenters, was 1.165, while the temperature of the enclosure increased by equal steps of 20° C.

The formula of radiation obtained by Dulong and Petit, which does not express the facts with great exactness, is

$$R = ma^t + k,$$

where R is the quantity of heat radiated in unit time from unit area of the surface at the temperature t , m is a constant depending on the substance and the nature of the surface, a is a constant equal to 1.0077 for the Centigrade scale, and k is a constant not yet determined.

From an examination of the data of Dulong and Petit, Stefan concluded that the radiation emitted is proportional to the fourth power of the absolute temperature, or

$$R = n (273 + t)^4,$$

where n is a constant and t is the temperature of the radiating body. A similar expression holds for the rate of cooling if the specific heat of mercury be assumed to be constant. If t is the temperature of the enclosure and t' the excess of temperature of the thermometer, then the rate of cooling will be the difference between the radiation of the thermometer and the counter radiation of the walls of the enclosure, and we may write :

$$\text{Rate of cooling} = n (273 + t + t')^4 - n (273 + t)^4.$$

This formula has been deduced theoretically by Boltzmann, and is in better agreement with more recent experiments than that of Dulong and Petit.

The rate of convective cooling in a gas was expressed by Dulong and Petit as follows :

$$r = ap^{bt^{1.223}},$$

where a and b are constants for any given gas, p is the pressure, and t the excess of temperature of the cooling body over the gas. This rate is independent of the nature and surface of the body, but varies with its form and dimensions.

CHAPTER IX.

THERMODYNAMICS.

85. **First Law of Thermodynamics.** — A short account of the experiments of Rumford and Davy has already been given in Chapter I. They go to show that heat implies motion of the invisible particles of matter, and that heat is the energy of this motion. The science of thermodynamics is based on two fundamental laws relating to the conversion of heat into work. The first law is the principle of Conservation of Energy applied to heat. It postulates the equivalence between heat and energy, and may be expressed as follows:

When work is transformed into heat or heat into work, the quantity of work is dynamically equivalent to the quantity of heat.

It has also been expressed in this way:

“When equal quantities of mechanical effect are produced by any means whatever from purely thermal sources, or are lost in purely thermal effects, equal quantities of heat are put out of existence, or are generated” (Kelvin).

This law has been confirmed in a variety of ways:

1. The experiments of Joule, Rowland, and others in generating heat by the expenditure of work.
2. The experiments of Hirn and others, showing that when work is done by a heat-engine heat disappears. Hirn made a fair calculation of the ratio between the two.

3. Investigations on the specific heat of air and other gases under the two conditions of constant pressure and constant volume permit of the calculation of the ratio between the units of heat and of work. This calculation was first made by Dr. Julius Mayer in 1842.

The limits of this book will restrict the discussion to the first of these investigations.

86. **Joule's Experiments (P., 575).** — The investigations of Joule to determine the dynamical equivalent of heat, or the ratio between the units of heat and of work, are examples of the highest class of experimental research. Rumford made a rough calculation of the mechanical work expended in heating a pound of water one degree; Joule investigated this relation by a long series of varied and elaborate experiments which left little for subsequent investigators, except the refinement of details and an increase in the scale on which the experiments were conducted. The results

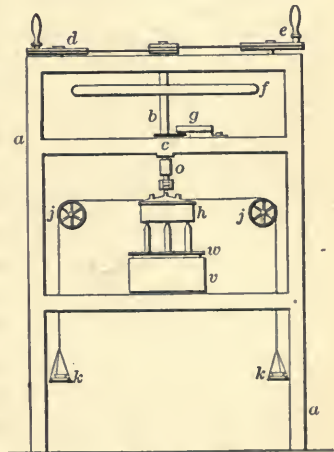

Fig. 38.

of all his experiments were fairly concordant, and a brief description of the latest one of 1878 must suffice here.

The plan was to heat water by churning it with paddles, and to find the ratio between the work expended in turning the paddles and the number of heat units generated. Hence both the work done and the heat generated had to be measured.

The former was accomplished by an arrangement devised by Hirn. The calorimeter h (Fig. 38), containing the water, was supported on a hollow cylindrical vessel w , which floated in water in v . It was thus free to turn around a vertical axis, and the pressure was taken off the bearings. The paddles within the calorimeter were carried on a vertical axis b , about which the calorimeter could also turn. A piece of box-wood was inserted in the axis at o to prevent the conduction of heat downward from the bearing c . There was a horizontal fly-wheel at f , and the paddles were turned by the hand-wheels d and e .

To prevent the turning of the calorimeter by the friction of the water, two thin silk strings were wound in a groove around it, and, passing over two light pulleys, carried weights k, k . These weights were adjusted till they remained stationary, while the shaft and paddles revolved at a suitable uniform speed, which was recorded by the counter g . The weights then gave the torque necessary to keep the calorimeter at rest, or the moment of the force exerted by the paddles on the water. To measure the work transmitted, it was then only necessary to multiply this moment by the angular velocity of the shaft.

Let w be the mass of each weight, r the radius of the groove in the calorimeter, and n the number of rotations per second. Then since the work done is the same as if the axle and paddles were at rest, and the calorimeter was made to turn n times per second by the fall of the weights, the energy expended can be readily calculated. In one turn the weights would descend a distance $2\pi r$. Hence in n turns the work is

$$2\pi r \times n \times 2wg = 4\pi nrwg.$$

$2\pi n$ is the angular velocity of the axle, and $2rwg$ is the moment of the couple made by the two weights.

To measure the heat generated, let M be the mass of water and m the water equivalent of the calorimeter and paddles, and let t be the rise in temperature. Then the heat generated is $(M + m)t$. The ratio of the work done to the heat generated is

$$\frac{4\pi nrwg}{(M + m)t}.$$

Corrections for radiation and other losses are required. Joule's experiments proved that this ratio, which is the work done to produce a unit of heat, is constant. It is called Joule's equivalent, and is represented by the letter J .

The fundamental equation expressing this law is

$$W = JH,$$

where W is the number of units of work and H the number of units of heat.

Joule's final value for J in gravitational units was 1390.59 ft.-lbs. or 423.85 kilogramme-metres. That is, the heat which will raise a kilogramme of water 1° C. will, if applied mechanically, lift 423.85 kilogrammes 1 metre high at sea-level. Of course the gramme can be substituted in this expression without other change.

87. Rowland's Experiments (P., 583). — In 1879 Rowland extended the work of Joule by a series of exhaustive experiments which leave nothing to be desired. His object was to reduce the temperatures to those of the air thermometer, and to increase the rate at which the work was done and the heat was generated.

Rowland's plan was the same in principle as Joule's, the chief differences being that the paddles were turned from below by power derived from a steam engine, and the revolutions were recorded on a chronograph. On the

same chronograph were recorded the transits of the mercury over the divisions of the thermometer. The rate at which heat was generated in Rowland's apparatus was 50 times as great as in Joule's. Joule's rate of increase of temperature was only $0^{\circ}.62$ C. per hour, while Rowland's was 35° . The correction for radiation was thus reduced in the inverse ratio of the rates.

For the sake of comparison, Rowland reduced Joule's results to the air thermometer and the latitude of Baltimore, where his own experiments were conducted. Combining the results, he deduced 426.75 from Joule's experiments, and 427.52 gramme-metres from his own, both at $14^{\circ}.6$ C. His series of experiments at different temperatures shows that the specific heat of water is a minimum at about 30° C.

To reduce Rowland's result to C.G.S. units, the above quantity must be changed to gramme-centimetres and then multiplied by the value of g at Baltimore, which is 980.05. Hence

$$J = 427.52 \times 100 \times 980.05 = 4.19 \times 10^7 \text{ ergs,}$$

or one calorie is equivalent to 4.19×10^7 ergs.

88. The Relation between J and R. — The constant R in the equation for a perfect gas, $pv = RT$, is numerically equal to the dynamical equivalent of the difference between the two specific heats of a gas (34). The demonstration is as follows: If v be the volume of unit mass of the gas at absolute temperature T , then v/T is the increase in volume, or the expansion, for one degree, and pv/T is the work done by the gas during the expansion under pressure p (I., 44). The specific heat at constant volume S_v is the heat required to raise the temperature of unit mass one degree when the volume is kept constant; while the specific

heat under constant pressure S_p is the heat required to raise the temperature of the same mass one degree when the pressure is kept constant. Since there is no internal work, the latter will exceed the former by the thermal equivalent of the work done in expanding under constant pressure. Hence we may write

$$J(S_p - S_v) = \frac{pv}{T} = R.$$

R may be evaluated if the density is known. Let d be the density of the gas; then since v is the volume of unit mass, $dv = 1$, and $R = p/Td$.

For air $d = 0.001293$ when $p = 76$ cms. of mercury = 1033.3 gms. per square cm. = $1033.3 \times g$ dynes. Therefore

$$R = \frac{1033.3 \times g}{0.001293 \times 273} = 2,927 g.$$

For any other gas the value of R may be found by dividing the value of R for air by the relative density of the gas.

S_p for air is 0.2374 (Art. 34); if the ratio between the two specific heats be assumed to be 1.41, in accordance with the best experimental results, then the above equation expressing the relation between J and R will give for J the value of 42,420 gramme-centimetres, or 4.16×10^7 ergs.

89. Coefficient of Elasticity of a Gas (M., 106). — Before proceeding to the second law of thermodynamics it is desirable to introduce some topics subsidiary to it. Since the working medium for the conversion of heat into work is usually a gas or a vapor, a few propositions relating to them are necessary.

The coefficient of elasticity of a fluid is the ratio between any small increase of pressure and the resulting

voluminal compression. Let V be the initial volume and v the diminution in volume due to an increment of pressure p . Then v/V is the compression per unit of volume. The quotient of the increment of pressure by this compression is the coefficient of elasticity of volume; or, in symbols,

$$p \div \frac{v}{V} = p \frac{V}{v} = e.$$

Since voluminal compression is only a ratio, the coefficient of elasticity is a quantity of the same kind as a pressure.

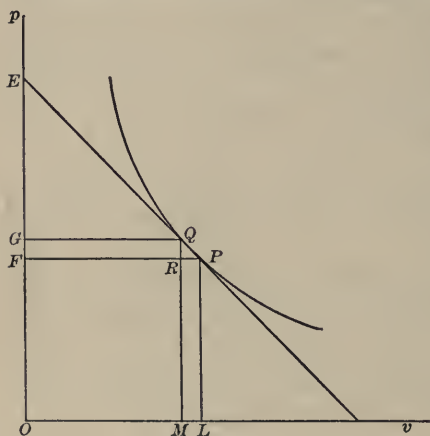

Fig. 39.

Let volumes be represented by abscissas and corresponding pressures by ordinates (Fig. 39). Then to volume FP will correspond pressure LP . If now the pressure be increased to MQ , the volume will decrease to GQ . The coördinates of the point P represent the initial and those of Q the final condition of the

body with respect to volume and pressure, the temperature remaining constant.

Join P and Q and produce the line to its intersection E with the axis of pressures. Then will FE represent the coefficient of elasticity. For

$$\frac{FE}{RQ} = \frac{FP}{RP}.$$

But RQ is the increment of pressure, and $\frac{FP}{RP} = \frac{V}{v}$.

Hence

$$FE = RQ \frac{FP}{RP} = p \frac{V}{v} = e.$$

If therefore the relation between the volume and pressure of a gas under the condition of a constant temperature be represented by a curve traced by the point P , then the coefficient of elasticity for any point P may be found by drawing PE tangent to the curve at P and a horizontal line PF ; the portion FE of the axis of pressures included between PE and PF will represent the coefficient of elasticity on the same scale as the pressures.

If the temperature is not constant, but is increased by the compression, the effect will be to increase the increment of pressure for any given decrement of volume. Hence the corresponding coefficient of elasticity will be increased. It is therefore evident that a gaseous substance has two coefficients, one corresponding to constant temperature and the other to the case where no heat is allowed to escape or to enter during compression or expansion. The first is applicable to long continued stresses; the second to rapidly changing or alternating forces, as in the vibrations constituting sound, in which there is insufficient time for the equalization of temperature by conduction and radiation. The ratio of these two elasticities is the same as that of the two specific heats.

90. Isothermal Lines (M., 108; S., 438). — If the ordinates of the curve traced by P represent pressures and the abscissas volumes of a gas at constant temperature, then the curve expresses the relation between p and v and

is called an *isothermal* line (Fig. 40). If the temperature be increased to $T+1$ and be kept at this value, another isothermal line will be obtained lying wholly above the one for T . In this way any number of isothermal lines may be drawn corresponding to regular intervals of temperature. From such a diagram it is evident that, when

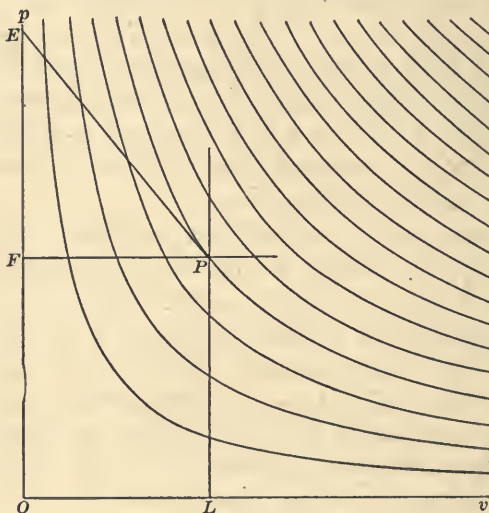

Fig. 40.

two out of the three quantities p, v, T , are given, the third may be found graphically.

If the substance follows Boyle's law, then for a constant temperature pv is a constant, and this product is represented in the figure by the area $OFPL$. If this area is constant the curve is known as a rectangular hyperbola.

The isothermal line corresponding to any temperature is therefore a rectangular hyperbola.

It is a property of this hyperbola that if a tangent to the curve be drawn through any point P till it meets Op in E , then OF equals FE . But FE equals the coefficient of elasticity of the gas and OF is the pressure. Hence the coefficient of a perfect gas obeying Boyle's law is numerically equal to the pressure. This result was reached in another way in the theory of sound (I., 118).

91. Adiabatic Lines. — It remains to consider the properties of a gas under the condition that no heat enters or leaves it during the expansion or compression. If the point traces a line expressing the relation between volume and pressure in this case, it is called an *adiabatic* line. When adiabatic lines cross isothermal lines, they are always inclined to the horizontal at a greater angle than the isothermal lines, because as the gas expands the pressure diminishes more rapidly than for an isothermal line, since the temperature is reduced by the work done in expanding under pressure.

The equation to an adiabatic line is

$$pv^\gamma = \text{a constant.}^1$$

¹ Let dQ be the quantity of heat required to raise unit mass of a perfect gas through the temperature difference dT under constant pressure p . This heat is all expended in changing the temperature and doing external work. The quantity required for the former purpose is $S_v dT$. If the volume increases by a quantity dv under pressure p , the work done is $p dv$, and the heat required is $(p dv)/J$. Hence the whole heat necessary to effect the transformation is

$$dQ = S_v dT + \frac{p dv}{J}.$$

When a gas expands adiabatically no heat enters or leaves it, and $dQ = 0$. Therefore

$$S_v dT + \frac{p dv}{J} = 0.$$

Differentiating the equation $pv = RT$, we have

$$p dv + v dp = R dT.$$

Substituting in the last equation the value of dT obtained from this one, and replacing R by its value $J(S_p - S_v)$ from Art. 88, we have

$$S_p p dv + S_v v dp = 0.$$

If γ denotes the ratio S_p/S_v , then

$$\gamma \frac{dv}{v} + \frac{dp}{p} = 0.$$

Integrating,

$$\gamma \log v + \log p = \text{constant,}$$

or,

$$pv^\gamma = \text{constant.}$$

92. **Carnot's Cycle (M., 138).** — If a volume of gas v_1 at pressure p_1 and temperature T_1 is allowed to expand isothermally to the condition v_1' and p_1' represented by the point B (Fig. 41), then work has been done against external forces equal to the area $ABv_1'v_1$ (I., 44). If now the gas expands adiabatically from condition B at temperature T_1 to condition C at temperature T_2 , then the gas does work represented by the area $BCv_2'v_1'$.

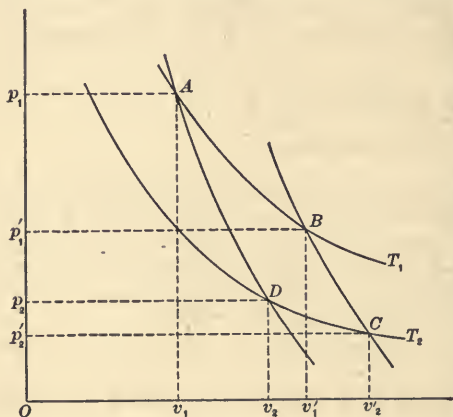

Fig. 41.

Suppose now the gas to be compressed isothermally along the line CD . Then the work is done on the gas with loss of heat, or is negative, and it is represented by the area CDv_2v_2' . Lastly let the gas be compressed adiabatically from condition D to condition A . Then the work done on the gas raises its

temperature from T_2 to T_1 and equals the area DAv_1v_2 . The algebraic sum of the several parts of the work is then the area $ABCD$, enclosed between the two isothermals and the two adiabatics.

The working substance has returned to its initial volume, pressure, and temperature, and has gone through an operation called a *cycle*. It is known as Carnot's Cycle. The advantage gained by supposing the working substance carried through a complete cycle of operations is that there is then no balance of work done by or against internal

forces, as there might be if the substance were not left in its initial state.

If H_1 is the quantity of heat supplied at the higher temperature T_1 , and H_2 the heat lost to surrounding bodies at the lower temperature T_2 , then

$$\frac{\text{Heat utilized}}{\text{Heat supplied}} = \frac{H_1 - H_2}{H_1} = \frac{T_1 - T_2}{T_1} = \frac{w}{W} = \text{efficiency.}$$

93. Carnot's Engine. — Carnot's engine is an ideal one designed to embody the series of operations described

in the last article. Suppose D , the working substance (Fig. 42), to be contained in a cylinder imper-
 vious to heat except through its bottom, which is as-

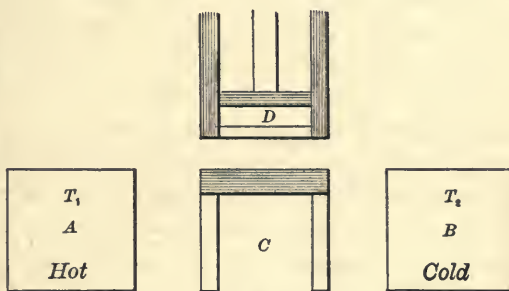

Fig. 42.

sumed to be a perfect conductor. Let A and B be two stands, the temperatures of which are maintained at the values T_1 and T_2 respectively. C is another stand the top of which is supposed to be perfectly non-conducting. Suppose the working substance D at the temperature of the hot stand T_1 , and that its volume and pressure are represented by v_1 and p_1 , the coördinates of the point A on the isothermal line AB in the diagram of the last article. Then we shall have the following operations:

First Operation. Place the cylinder containing the working substance D on A and allow the piston to rise. Heat flows in through the bottom of the cylinder to keep

the temperature of the working substance at the point T_1 , and the substance expands along the isothermal line AB to the point B . During this operation the substance is doing work by its pressure against the piston. It is positive and is denoted by the area $ABv_1'v_1$. During this operation a quantity of heat H_1 has passed from A into the substance.

Second Operation. The cylinder is now transferred to the non-conducting stand C and the substance is allowed to expand adiabatically, thus losing heat till its temperature falls from T_1 to T_2 . Its expansion is represented by the adiabatic line BC . The work done by the substance during this process is equal to the area $BCv_2'v_1'$.

Third Operation. The cylinder is next placed on the cold body B , and the piston is pressed down till the volume and pressure are represented by the coördinates of D . Heat passes out through the bottom of the cylinder, the substance remaining at the temperature T_2 . Its compression is represented by the isothermal line CD , and the work done on it equals the area CDv_2v_2' ; this work is negative. During this operation a quantity of heat H_2 has flowed from the working substance into the cold body B .

Fourth Operation. Finally place the cylinder on C and force the piston down. The temperature rises and the relation of the volume and the pressure will be represented by the adiabatic line DA . Continue the operation till the temperature has risen to that of the hot body T_1 . Then work equal to the area DAv_1v_2 is done on the substance, and is negative.

The substance has thus passed through a series of operations by which it has finally been brought back in all respects to its initial state. When the piston is rising the substance is doing work; this is the case in the first and

second operations. When the piston is sinking it is performing work on the substance; this is the case in the third and fourth operations. The useful work done by the substance is the difference between the positive and negative work, and is represented by the area $ABCD$.

The physical results at the end of the cycle are the following:

- (1) A quantity of heat H_1 taken from A at the temperature T_1 during the first operation.
- (2) A quantity of heat H_2 communicated by the working substance to B at the temperature T_2 during the third operation.
- (3) The performance by the substance of work equal to the area $ABCD$.

94. Reversibility of Carnot's Engine (M., 149; S., 351).— Let us now suppose all the preceding operations to be reversed, or that the engine is worked backwards, or is reversed in all its physical and mechanical actions.

Beginning at the higher temperature and at volume v_1 , let the cylinder be placed on C and let the substance expand along the adiabatic line AD , while the temperature falls from T_1 to T_2 . Next place the engine on B and allow the substance to expand isothermally along DC . During this latter expansion heat H_2 will be taken from the colder body B ; and by the two expansions the body has done work denoted by the area $ADCv_2v_1$.

Now place the engine on C and compress adiabatically till the temperature rises from T_2 to T_1 . Then removing it to A , compress the substance isothermally along BA till it again returns to its initial volume and pressure. During the last compression, heat H_1 has been given out to A at the higher temperature T_1 , and work has been done in

compressing the substance adiabatically and isothermally in the two compressions equal to the area $CBAv_1v_2'$.

In this reverse action of the engine more heat has been given out to A at the higher temperature than has been drawn from B at the lower temperature, and more work has been done on the engine than by it equal to the area $ABCD$. It is possible then to convey heat from a colder body to a hotter one, but only at the expense of mechanical work.

95. **Carnot's Principle.** — Heat may be transferred from a hot body to a cold one either directly by conduction, or indirectly by means of an artificial engine, in such a way that part of the heat is converted into mechanical work; but heat never flows from a cold body to a hot one, and it can be thus transferred only by artificial means and at the expense of mechanical work.

What is known as Carnot's principle, derived from a consideration of his reversible engine, is as follows: "If a given reversible engine, working between the upper temperature T_1 and the lower temperature T_2 , and receiving a quantity H_1 of heat at the upper temperature, produces a quantity w of mechanical work, then no other engine, whatever be its construction, can produce a greater quantity of work when supplied by the same amount of heat and working between the same temperatures."

Suppose an engine M to have a higher efficiency than this reversible one. Let it be coupled to a reversible engine N working backwards. Then since M converts a larger portion of the heat H_1 into mechanical work than N requires to restore the heat H_1 from the refrigerator to the source, the two engines constitute an automatic arrangement by which M , by the use of heat H_1 , supplies to N

sufficient energy to enable it to restore to the source more heat than H_1 ; or, in other words, the coupled engines would run perpetually, transferring heat continuously from colder bodies to hotter ones. Such an operation is denied by experience, and is inadmissible. Therefore no engine can be more efficient than the ideal reversible one of Carnot.

96. **The Second Law of Thermodynamics.** — The second law of thermodynamics expresses a conception derived from Carnot's reversible engine, and is stated by Clausius as follows :

“It is impossible for a self-acting machine, unaided by any external agency, to convey heat from one body to another at a higher temperature.”

Lord Kelvin gives it in a slightly different form :

“It is impossible, by means of inanimate material agency, to derive mechanical effect from any portion of matter by cooling it below the temperature of the coldest of the surrounding objects.”

These statements apply only to the performance of engines working in a complete cycle. Without this limitation it is evident that the heat of a body, that of a compressed gas for example, may be converted into work by cooling it below surrounding objects.

Since the quantities of heat taken in and given out by a reversible engine depend only on the temperatures of the source and the cooler, the ratio of the two temperatures may be made equal to that of the quantities of heat to form a scale of temperature. Then $H_1/H_2 = T_1/T_2$. Such a scale agrees with that of a perfect gas thermometer.

CHAPTER X.

THE KINETIC THEORY OF GASES.

97. **Molecular Hypotheses.**—The comparative simplicity of the laws relating to gases has stimulated inquiry into a kinetic theory to account for them on simple dynamical principles. The results are encouraging to the extent that they exhibit satisfactory agreement between the deductions from theory and the laws established by experiment.

Certain preliminary hypotheses relating to molecular motion in gases are assumed, though not without justification. Since it cannot be assumed that all like molecules even have the same velocity, the statistical or average method is adopted, which applies the reasoning to certain groups of molecules whose velocities do not differ by more than a very small quantity from a mean value. It is then possible to discover definite relations between the physical properties of such a group without knowing anything about the performance of individual molecules.

Some of the hypotheses are the following:

(1) Molecules of the same gas are alike, and are separated by intervals which are very great compared with the size of the molecules. This inference is drawn from the fact that when a gas is heated so as to become luminous the colors emitted are independent of the pressure; that is, the colors depend on the nature of the molecules

and not on the distance between them; for if the molecular distances were relatively small, mutual action would ensue, and this action would depend on the pressure which changes the intervals between the molecules.

(2) The molecules of a gas move in straight lines between mutual encounters. Their motion for any excursion is uniform and rectilinear. The phenomena of diffusion exhibit rectilinear motion.

(3) All molecules of the same gas have equal masses, and the average kinetic energy is the same for all molecules at the same temperature.

(4) When two sets of molecules of different kinds are placed in the same enclosure, kinetic and thermal equilibrium ensues. The average kinetic energy of translation for one set is then the same as for the other; this statement may be extended to any number of sets. If m_1 and m_2 are the two molecular masses, then

$$\frac{1}{2}m_1v_1^2 = \frac{1}{2}m_2v_2^2, \text{ or } \frac{m_1}{m_2} = \frac{v_2^2}{v_1^2};$$

$\frac{1}{2}mv^2$ is called the average kinetic energy of agitation of a single molecule. The velocity v is "the square root of the mean square" of all the molecules whose velocities differ by only a small amount. The squares of the rates of diffusion of different gases through small pores are inversely as their molecular masses. Thus, hydrogen diffuses four times as fast as oxygen. This should be the case if the two gases have the same molecular kinetic energy at the same temperature as assumed.

98. Theory of the Pressure of a Gas (M., 319; P., 69).—Let a molecule of mass m approach the side of a cubical box of unit volume with a normal velocity u . If it rebounds with the same velocity, the change in momentum

will be $2mu$. If the molecule moves backwards and forwards between two opposite sides of the box with velocity u , it will strike each side $\frac{1}{2}u$ times a second, since the space traversed between two successive impacts on the same wall is two linear units. Hence the total change of momentum of the molecule per second with respect to the wall is

$$2mu \times \frac{1}{2} u = mu^2.$$

If the unit cube contains n such molecules, then the pressure, which is the rate of change of momentum, will be

$$p = \Sigma mu^2 = m\Sigma u^2.$$

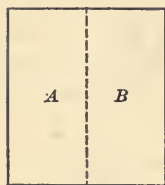

Fig. 43.

But if u^2 is the mean of the squares of all the velocities normal to the face of the cube, then $nu^2 = \Sigma u^2$, and

$$p = mn u^2.$$

In general a molecule may be moving in any direction with a velocity v . If we suppose that u is the velocity normal to the plane between A and B (Fig. 43), and u_1, u_2 , the two other rectangular components, then

$$v^2 = u^2 + u_1^2 + u_2^2.$$

If now V^2 denotes the mean of the squares of all the molecular velocities of the different groups, with corresponding meanings for U^2, U_1^2, U_2^2 , then

$$V^2 = U^2 + U_1^2 + U_2^2.$$

But since the molecules do not accumulate in any part of the enclosure, as many passing on the average across the plane between A and B in one direction as the other, the pressure in all directions will be the same, or

$$U^2 = U_1^2 = U_2^2 = \frac{1}{3} V^2.$$

Therefore when the molecules are moving in all directions within the cube, the pressure on each face of unit area will be

$$p = \frac{1}{3} mn V^2$$

While we may not know the absolute mass of each molecule nor the number in unit volume, yet the product mn of the two is the mass in unit volume, or the density. Hence

$$p = \frac{1}{3} d V^2.$$

The pressure is therefore one-third the product of the density of the gas and the mean square of the molecular velocity.

99. Mean Square of the Velocity of Hydrogen.—

From the preceding expression Joule calculated the square root of the mean square of the velocity of hydrogen as follows:

The data are, $d = 0.0000896$; $p = 1033.3 \times 980$ dynes. Hence

$$V = \sqrt{\frac{3 \times 1033.3 \times 980}{0.0000896}} = 184,133 \text{ cms. per second,}$$

or in round numbers 184,000. This is the value for the hydrogen molecule between impacts at 0°C. and 76 cms. pressure.

100. Deduction of Boyle's Law.—If v denotes now the volume containing unit mass of the gas, then

$$p = \frac{1}{3} \frac{V^2}{v} \text{ and } pv = \frac{1}{3} V^2.$$

Since heat is energy of motion, the mean square V^2 is a

function of the temperature of the gas only. Consequently pv at any one temperature is a constant; this is Boyle's law "raised from the rank of an experimental fact to that of a deduction from the kinetic theory of gases."

101. Law of Gay-Lussac. — Consider two gases in thermal equilibrium. Then for the two we have

$$p_1 = \frac{1}{3}m_1n_1v_1^2 \text{ and } p_2 = \frac{1}{3}m_2n_2v_2^2.$$

If the pressures are equal

$$m_1n_1v_1^2 = m_2n_2v_2^2.$$

But since they have the same temperature

$$m_1v_1^2 = m_2v_2^2,$$

for the mean kinetic energy of translation of the molecules is the same for each gas at the same temperature.

Dividing the two equations member by member and

$$n_1 = n_2,$$

or equal volumes of all gases at the same temperature and pressure contain the same number of molecules. This is known as the law of Gay-Lussac or of Avogadro. While this demonstration cannot be considered as stringent, it shows that this hypothesis is entirely in harmony with the kinetic theory of gases.

If we put $d_1 = m_1n_1$ and $d_2 = m_2n_2$, then since $n_1 = n_2$ we have

$$\frac{d_1}{d_2} = \frac{m_1}{m_2},$$

or the densities of two gases at the same temperature and pressure are directly proportional to their molecular masses or weights.

102. **Total Molecular Energy.** — The mean kinetic energy of agitation of a molecule is $\frac{1}{2}mV^2$. But its energy may be due partly to the vibration of its parts and to rotation. Clausius and others have assumed that the energy of internal agitation tends toward a value having a constant ratio to the energy of agitation of the molecule as a whole. The whole energy will then be proportional to the energy of agitation, and may be written

$$\frac{1}{2}\beta m V^2.$$

Then the total kinetic energy of the gas contained in unit volume of n molecules is

$$K_v = \frac{1}{2}\beta mn V^2.$$

But since $p = \frac{1}{3}mn V^2$,

$$K_v = \frac{3}{2}\beta p.$$

The energy per unit mass may be found by multiplying the energy per unit volume by the number of units of volume containing unit mass, or

$$K_m = \frac{3}{2}\beta pv.$$

103. **Specific Heat at Constant Volume.** — Since the product pv is proportional to the absolute temperature, the last equation shows that the energy per unit mass is also proportional to the temperature on the absolute scale. The specific heat at constant volume is the increase in the energy of unit mass for one degree increase of temperature. Hence in dynamical units

$$JS_v = \frac{3}{2}\beta \frac{pv}{T};$$

that is, the entire energy divided by the number of degrees of temperature gives the energy corresponding to one degree.

Now since $p v / T$ is a constant for gases obeying the laws of Boyle and Charles, it follows that the specific heat at constant volume must be constant for any gas, whatever its pressure and temperature. This conclusion is in harmony with the experimental results of Regnault (34).

For different gases the specific heat is directly proportional to the volume v containing unit mass, or inversely proportional to the density and directly proportional to β . Since β is nearly the same for several gases, the specific heat of these gases is inversely as their densities, or inversely as their molecular weights; and therefore the product of specific heat and molecular weight is the same for all such gases. This is the law of Dulong and Petit.

104. Ratio of the Two Specific Heats. — The thermal capacity of any mass M of a gas at constant volume consists of the energy of the molecular motion of translation plus the energy of the internal motions of the molecules for one degree of temperature. If E denotes this internal energy for one degree, then in dynamical units

$$JS_v = \frac{1}{2} \frac{MV^2}{T} + E.$$

Also, since the work done in expanding unit mass of a gas under constant pressure is $p v / T$ for one degree rise of temperature, we may write for the thermal capacity under constant pressure,

$$JS_p = \frac{1}{2} \frac{MV^2}{T} + E + \frac{p v M}{T}.$$

From (100) $pv = \frac{1}{3}V^2$. Therefore,

$$JS_p = \frac{1}{2} \frac{MV^2}{T} + E + \frac{1}{3} \frac{MV^2}{T}.$$

Therefore, to find the ratio of the two specific heats,

$$\frac{S_p}{S_v} = \gamma = \frac{\frac{1}{2} \frac{MV^2}{T} + E + \frac{1}{3} \frac{MV^2}{T}}{\frac{1}{2} \frac{MV^2}{T} + E} = \frac{\frac{5}{6} \frac{MV^2}{T} + E}{\frac{1}{2} \frac{MV^2}{T} + E}.$$

But E is necessarily positive; hence γ must always be less than $\frac{5}{3}$ or 1.667, which would be its value if E were zero. As E increases, γ approaches unity. These conclusions are justified by experiment as shown by the following table:

	γ		γ
Mercury	1.666	Chloroform . . .	1.200
Oxygen	1.404	Methyl ether . .	1.113
Nitrogen	1.410	Ethyl ether . . .	1.029
Ammonia	1.300		

The value of γ approaches its upper limit only in the case of mercury, which is the only monatomic gas examined. The simple constitution of such a gas would lead to the anticipation that its internal molecular energy is negligible as compared with the energy of molecular translation. In all other gases the internal energy is very appreciable, and it increases as the number of atoms in the molecule increases. As the molecule becomes more complex, its internal energy represents a larger fraction of the heat applied to warm the gas.

ELECTRICITY AND MAGNETISM.

CHAPTER XI.

ELECTRIC CHARGES.

105. **Electricity and Electrification.** — The simple elementary phenomenon that a piece of amber, rubbed with a flannel cloth, acquires the property of attracting bits of paper, pith, or other light bodies has been known since about 600 B.C. But it appears not to have been known for the following 2,200 years that any bodies except amber and jet were capable of this kind of excitation. About 1600 Gilbert, an English physician, discovered that a large number of substances possess the same property. These bodies he styled *electrics*, but the word *electricity* to designate the invisible agent concerned in the phenomena appears to have been introduced by Boyle in 1675.

Electrical phenomena are now well understood, but the nature of electricity remains obscure. It was long supposed to be a kind of subtle fluid; in later times philosophers were disposed to consider it a form of energy transformable into heat and light. But it is now quite certain that, while it may be a form of attenuated matter, like the ether, it is not energy. "It is quite true that electricity under pressure or in motion represents energy, but the same thing is true of water or air, and we do not therefore deny them to be forms of matter." When a body is electrically excited

it is said to be *electrified*, and *electrification* is always a result of work done in charging with electricity. Electrification, or electricity under pressure, is therefore a form of potential energy, just as air under pressure and water elevated above the earth represent potential energy. But air and water on the one hand and electricity on the other are not energy, but only its vehicles or receptacles.

Electricity, like matter and energy, appears to be indestructible. Its distribution is subject to control; it may be put under electric pressure, or be endowed with kinetic activity; it may represent energy of stress or energy of motion; but when its energy has been spent in producing physical effects, its quantity has suffered no diminution. It has simply been strained and moved like matter. The only way to charge a body is to pass to it electricity from outside; none can be created or generated and none destroyed.

106. **Division of the Subject.** — The study of electric currents began near the close of the eighteenth century, and the earlier observed phenomena relating to them were widely differentiated from the older manifestations of electrostatic charges. It has therefore long been customary to divide the entire subject into three grand divisions, viz.: static electricity, magnetism, and current electricity. But since all the phenomena of electrostatics can be produced by means of electricity set in motion and put under stress by batteries or dynamo-electric machines, it is apparent that electricity, however excited, is one and the same agent. At the same time magnetism is inseparable from electric currents and must be studied in connection with them. While, therefore, the general phenomena and laws of electrostatics, or electricity in equilibrium under pressure,

are conveniently studied together, it should be clearly perceived that this is merely a matter of convenience, and that such a classification is not imposed by fundamental differences. Electric charges and electric sparks may now be produced as well from one source of electricity as another; and magnetism may be evoked by electrostatic discharges, by electric convection, and by electric currents. Nevertheless it will be convenient to study first the facts and principles applying especially to electrostatics, and then those relating to electric currents and their magnetic effects. A fourth division for purposes of classification comprises the study of periodic or undulatory disturbances propagated through the ether as waves of electromagnetic origin. This subject is the most difficult one of all, but possesses for us surpassing interest. It includes the electromagnetic theory of light, elaborated by Maxwell and confirmed experimentally by Hertz.

107. **Attraction and Repulsion.** — Support a small



Fig. 44.

Support a small pith-ball by a silk fibre (Fig. 44) and present to it a warm glass tube excited by rubbing with a piece of silk. The pith-ball will first be attracted, but if it be allowed to come in contact with the electrified glass, it will

then be strongly repelled. If a stick of sealing-wax, electrified by rubbing with flannel, be used instead of the glass tube, the results will be exactly similar.

Two facts are clearly exposed by this experiment: (1) A body may be charged by contact with an electrified body. (2) When one body is charged by contact with another the two repel each other.

Boyle discovered that the attraction between the electrified and the unelectrified body is mutual. Excite a glass tube and lay it in a light wire stirrup supported by a silk thread (Fig. 45). If the hand be presented to it, it may be made to swing round by the attraction. Force, whatever its origin, is of the nature of a stress in the medium, and action and reaction are equal (I., 42).

108. Two Kinds of Electrification. — Not all electrified bodies repel each other. If a second excited glass tube be presented to the one hung in the stirrup (Fig. 45), there will be mutual repulsion between them. On the contrary, an excited stick of sealing-wax will attract the pith-ball charged by contact with an electrified glass tube; and if the pith-ball be charged by contact with the rubbed sealing-wax, it will be repelled by the sealing-wax, but attracted by the glass tube rubbed with silk.

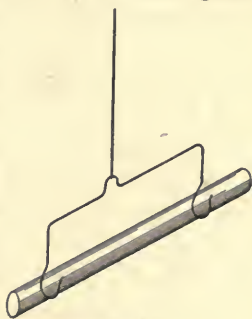

Fig. 45.

So if two or three pith-balls, hung by silk fibres (Fig. 46), be touched either with an excited glass tube or a stick of electrified sealing-wax, they will fly apart by mutual repulsion. It is, therefore, inferred that there are two kinds of electrification, or that electricity manifests

itself under two opposite aspects, analogous to the opposite properties possessed by the two poles of a magnet. The electricity excited by rubbing glass with silk Du Fay called *vitreous* electricity; and the electricity excited on such substances as sealing-wax, resin, amber, shellac, and hard rubber when rubbed with flannel, he called *resinous*

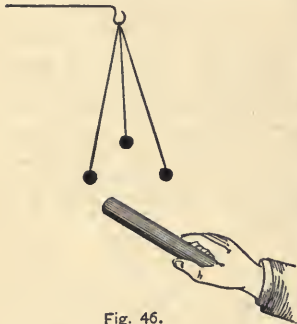

Fig. 46.

electricity. The former Franklin called *positive* and the latter *negative* electricity; and this classification is better than Du Fay's, since glass does not always show positive nor resin negative electrification. The result of friction depends on the rubber as well as on the material rubbed.

From such experiments as the foregoing is derived the first law of electrostatics, viz., *bodies similarly electrified repel and those oppositely electrified attract one another.*

The student should guard against the inference, from the expression "two kinds of electrification," that there are two kinds of electricity, called positive and negative, respectively. Positive and negative forces constituting a stress are not essentially different forces, nor are positive and negative rotations different except in respect to algebraic sign. Yet in both cases the forces and motions may annul each other, as equal quantities of positive and negative electricity neutralize each other. The terms *positive* and *negative* are applied to electricity merely for the purpose of enabling us to describe concisely, and, to that extent, to explain certain electrical phenomena.

109. Conductors and Insulators. — Gilbert concluded

that some bodies were capable of electrical excitation and others were not. To substances like metals which gave no sign of electrification when held in the hand and rubbed he gave the name "non-electrics." In 1729, however, Stephen Gray discovered that Gilbert's "non-electrics" convey away the "electric virtue" as fast as it is excited, and therefore show no signs of electrification. If a metal rod be held by a glass handle, it can be excited by rubbing it with silk. Gray succeeded in conveying electric charges a distance of seven hundred feet by means of a hempen thread, suspended by silk loops, and Du Fay carried them to nearly double this distance by means of moistened thread. Ever since Gray's discovery bodies have been divided with respect to their power of conveying electricity into *conductors* and *non-conductors*, or *insulators*. The latter Faraday preferred to call *dielectrics*. It should be noted, however, that all bodies can be arranged in a graded series having the best conductors at one end and the poorest at the other. None conduct perfectly and none insulate perfectly. Pure copper, silver, and other metals are the best conductors; and the best insulators are silk, shellac, glass, and quartz. More definite data on the specific resistance of various conductors will be given in treating of electric currents.

110. **Electric Field and Lines of Force.**—The old mathematical notion of action at a distance has now been abandoned; and when there is attraction or repulsion between separated bodies, the action is conceived to take place through the agency of the intervening medium. This conception, developed by Faraday and elaborated by Maxwell in its application to electricity, has been very fruitful in discovery, and bears every mark of conforming to the truth.

In harmony with this view, a region within which the medium is under stress is said to be a *field of force*; and an *electric field* is one in which the forces acting are electric in their origin. For concreteness the stress in the medium is said to act along *lines of force*. An electric field may be completely specified by giving at every point in it the direction and magnitude of the resultant electric force. The direction of the force is best expressed by the device of lines of force. A line of force must be conceived, so drawn in the electric field that a tangent to it at any point represents the direction of the electric intensity at the point. For brevity the expression "force at a point" is used to signify the intensity of the force sustained by unit quantity of the active agent at the point, or the electric intensity at the point.

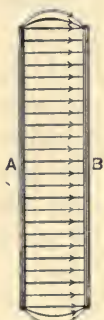

Fig. 47.

Lines of electric force always spring from a positively electrified surface and end in a negatively electrified one. The stress along these lines is a tension, tending to shorten them. It is accompanied by a pressure at right angles to the lines and tending to separate them.

When one electrified body attracts another, the two are drawn together by these taut lines of force stretching between them. When two plates oppositely electrified face each other (Fig. 47), lines of electric force stretch across from the positive to the negative, and the tension in the medium tends to draw the plates together.

111. Equal Charges of Opposite Sign. — When a body is electrically excited by friction, the body rubbed and the rubber are equally electrified, but with charges of opposite sign. The equality consists in the ability of the one

charge to exactly neutralize the other. If a stick of sealing-wax, provided with a flannel cap with a silk cord attached (Fig. 48), be excited by turning it around a few times inside the cap, it will not attract a positively electrified pith-ball if the cap be left on; but if the cap be withdrawn by the cord, the sealing-wax will attract the pith and the cap will repel it.

The electrification of a body consists in the separation of two equal charges of opposite sign against their mutual attraction. Hence the medium between them is strained by the operation, and work is done. A positively charged conductor, insulated by supports of glass, shellac, silk, or other non-conductors, is connected to other bodies by invisible lines of electric force, springing from the positive charge and extending to the equal negative one on surrounding bodies. The slightest charge of positive electricity at one point always means an equal charge of the opposite sign as near to it as the conductivity of the dielectrics permits.



Fig. 48.

Whatever operations of electrically exciting, discharging, and the like, may be carried on within an insulated conducting chamber, no signs of excitation will be exhibited without. The positive and negative excitations exactly neutralize each other outside the chamber.

112. Electroscopes.—An electroscope is an instrument for detecting electric charges. The simplest one, which was employed by Gilbert, consists of a long straw, turning freely on a sharp point, which must be insulated from the earth. A pith-ball suspended by a silk thread is also a convenient sensitive electroscope.

The Gold-leaf Electroscope is still more sensitive. Through the top of a glass jar passes a brass rod, terminating in a ball above, and bent at right angles below to receive two strips of gold leaf (Fig. 49). The top of the jar should be coated with shellac both within and without. Two strips of tin foil are pasted inside the jar from the

bottom up to the lower level of the gold leaves to prevent the latter from sticking to the glass when they are violently repelled.

If the knob be touched with a positively electrified glass tube the leaves will be mutually repelled with + charges. The approach of any other charged body will cause them to diverge more widely if the charge presented is +, and to approach each other if it is -.



Fig. 49.

113. Charge External. — When a conductor is electrified by friction or by electricity conveyed to it from some external source, the charge always resides on the outside. Biot devised a direct demonstration by fitting to an insulated copper ball two hemispherical copper shells. When the whole was charged and the shells were then deftly removed by glass handles, the charge was found to be entirely removed with them. A simple demonstration of the law is afforded by a hollow metal sphere with a hole at the top and insulated on a glass stem (Fig. 50). It may be tested by means of a proof-plane, which is

composed of a small metal disk with a shellac or ebonite handle. If the proof-plane be applied to the outside of the charged sphere, a small charge may be removed and tested by an electrosc pe. If the proof-plane be passed through the hole in the sphere and applied to the inner surface, it will be found on withdrawal to exhibit no trace of electrification. The proof-plane may be charged from the outside of the sphere, and then be made to touch the interior. It will lose all its charge and will show none on withdrawal.

Faraday constructed a cube 12 feet on each side and covered it with tin foil. He went inside of it with his electroscopes; but while it was charged so that long flashes were given off from the outside, he could detect no signs of electrification within.



Fig. 50.

114. Distribution of Charge. — The quantity of electricity (119) on unit surface of a conductor, or the ratio of the quantity on any small area to the area itself, is called the *surface density*. The distribution of an electric charge is not such as to give uniform surface density over an insulated conductor, except in the case of a sphere remote from other conductors and electrified bodies. The distribution on conductors of various shapes was investigated by Coulomb by means of the proof-plane and torsion balance (116). The following is a summary of results:

(1) On a cylinder with rounded ends the surface density is greatest at the ends.

(2) On a flat disk the density is much greater at the edges than on the flat surfaces, but over the latter the distribution is fairly uniform except near the edges.

(3) With two spheres in contact the charge is nothing at the point of contact, increases rapidly between 30° and 60° from that point, and becomes greatest at 180° . When the spheres are of unequal size, the density at corresponding points is greater on the small sphere than on the large one.

The density is greatest on those parts of a conductor which project most and have the greatest convexity. Hence at sharp points, such as that of a needle, the density is very great, and as a consequence the charge escapes rapidly from them. It is therefore necessary to round off all edges of insulated conductors and to make them smooth.

115. Redistribution of Charge. — Coulomb demonstrated that when a charged conducting sphere is brought into contact with an identical one in the neutral state, each will then possess a quantity equal to half of the original charge. If the second sphere, instead of being neutral, is itself charged, the final charges are again equal. Each of them is half the algebraic sum of the initial charges, so that both spheres will be neutral if those charges were equal and of opposite sign.

The result will be the same with two like conductors of any form whatever when one touches the other, provided they are symmetrical with respect to the point of contact. If this condition of symmetry is not fulfilled, the charges will divide unequally, but so that their algebraic sum always equals that of the initial charges.

Since the charge resides on the outside, if a small charged sphere be introduced into a larger hollow one, it will give up its charge entirely to the larger sphere. By this means a conductor may be charged by successive additions of small quantities, or one can increase or decrease the electric charge on the outside of a closed surface by introducing within small positive or negative charges.

116. Coulomb's Torsion Balance. — The torsion balance was invented by Coulomb for the purpose of investigating the law of attraction and repulsion between two charges of electricity. The instrument is now obsolete, but it illustrates the meaning of the law of inverse squares which was established by Coulomb's elaborate experiments.

From a torsion head *h* (Fig. 51) is suspended a very fine wire, carrying at its lower end a light shellac rod with a gilt pith-ball *b*. The shellac rod swings inside a protecting glass case, around which is a graduated scale *s* at the level of the gilt ball. A shellac rod, carrying another gilt ball *c*, can be introduced through a hole in the top of the case. The torsion head is divided into degrees, and is provided with an index. The rod carrying the torsion wire can be turned independently of the rest of the head, so that the index can be held at zero, while the rod and wire are turned till the movable ball just touches the fixed one without any torsion of the wire. Calcium chloride, or

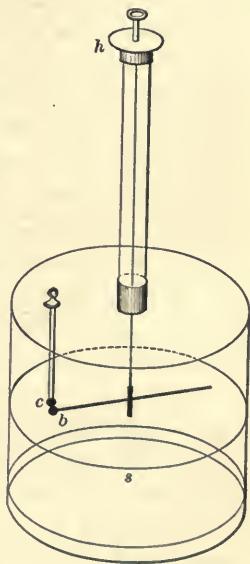

Fig. 51.

some other drying agent, is placed in the case to keep the air dry.

117. Law of Inverse Squares. — When the instrument has been set as described, the vertical rod is removed, the attached ball is charged, and is then replaced in the instrument. It touches the ball *b* and divides its charge with it. Repulsion follows, and the ball *b* moves away till the torsion couple of the suspending wire equals the moment of the force due to the mutual repulsion. The distance between the balls is not sensibly different from the arc of the circle separating them, if the balls are not many degrees apart. The balls are now made to approach each other by turning the torsion head and twisting the wire. The two divided circles then give the whole angle of torsion of the wire. The principle employed in comparing the forces is that when a wire is twisted, the couple of torsion is proportional to the angle through which the wire is twisted. For example, if the moments of the couples required to twist a wire through 10° and through 20° are measured, the latter will be found to be twice as great as the former.

The following data belong to one of Coulomb's experiments: The first deflection of the movable ball was 36° . To reduce it to 18° it was found necessary to turn the head through 126° ; and for a further reduction to 8.5° an additional rotation of 441° was required. The several relative distances of the balls were then about as 1 to $\frac{1}{2}$ to $\frac{1}{4}$, and the torsion of the wire was 36° for the first distance, $126 + 18 = 144^\circ$ for the second, and $441 + 126 + 8.5 = 575.5^\circ$ for the third. But 144 is 4×36 , and 575.5 is nearly 16×36 ; so that as the distance is reduced successively to $\frac{1}{2}$ and $\frac{1}{4}$, the force is increased to 4 and 16 times respectively.

The law of attraction was also investigated by a similar method, and was found to hold within the same limits. Also the dependence of the force on the charge was examined by touching one of the balls with an insulated one of the same size. Half of the charge was thus removed, and the force was found to be reduced to one-half. If the charge of either ball was reduced, the mutual force was reduced in the same ratio.

118. Second Law of Electrostatics.—The second law of electrostatic action, established by the experiments of Coulomb, may be enunciated as follows: *The force between two charged bodies is directly proportional to the product of the two charges, and inversely proportional to the square of the distance between them.*

The law of distance does not hold unless the dimensions of the charged conductors are very small in comparison with the distance between them. The charge on a sphere acts as if it were collected at its centre (121) only when the distribution of this charge is not affected by the influence of neighboring charges. In Coulomb's experiment the actual mean distance of the two charges when the balls were brought as near together as $8^{\circ}.5$ was greater than the distance between the centres of the spheres. The force between two flat disks near each other does not vary appreciably with a moderate change in the distance.

If the two quantities q and q' are on infinitesimal spheres, the distance of whose centres is r , then the force between them may be expressed by the formula

$$f \propto \pm \frac{q \times q'}{r^2}.$$

The positive sign corresponds to similar charges, and therefore to repulsion, and the negative sign to attraction.

119. **The Unit of Quantity.** — The definition of the electrostatic unit of quantity is derived from the law of attraction and repulsion. If the force in the foregoing proportion is to become unity when the distance and the charges are unity, unit quantity must be defined as follows: *The electrostatic unit of electricity is that quantity which repels an equal and similar quantity, at a distance of one centimetre in air, with a force of one dyne.*

Since the intensity of an electric force is the force exerted on unit quantity, it follows that the electric intensity at a point distant r centimetres in air from a charge q is q/r^2 . The reason for inserting the expression "in air" will appear later (165).

120. **Indirect Proof of the Law of Inverse Squares.**

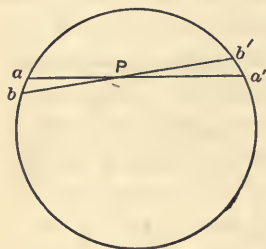

Fig. 52.

— It has already been pointed out that no electric force can be detected inside a hollow conductor. This experimental fact furnishes the basis of the most conclusive proof that the force varies inversely as the square of the distance.

The following may be considered as an illustration of the principle rather than a rigid mathematical demonstration: Let P (Fig. 52) be any point within a charged conducting sphere, and let a narrow cone of two sheets be described with P as the apex, and cutting the sphere in two areas s and s' at ab and $a'b'$ respectively. Then, since the surface density is supposed to be uniform, the quantities on the two areas are proportional to those areas; but the areas are proportional to the squares of their respective distances from P . To prove this latter relation, it must

be noted, first, that the two areas are sections of the cone equally inclined to its axis. Let ab and $a'b'$ (Fig. 53) be oblique sections of a cone making the same angle with the axis. Their linear dimensions are directly proportional to the distances PA and PB ; and since the areas of similar figures are proportional to the squares of their homologous dimensions, the areas of the two sections are proportional to the squares of PA and PB .

It follows that the two quantities on s and s' are proportional to the squares of Pa and Pa' . Hence the two forces acting on P are directly proportional to the squares of Pa and Pa' , and inversely proportional to some function of these distances. But since there is no force inside a charged sphere, and since the whole surface may be divided into a series of such pairs of sections made by a cone, and what is true of the whole is true of each pair, it follows that the forces due to the charges on s and s' are equal to each other. But the only function of the distances which will satisfy this condition is the inverse square. The forces are proportional to the acting quantities, which are directly proportional to the squares of the distances; the forces are also inversely proportional to the squares of the same distances; and, being opposite in direction, the resultant is zero.

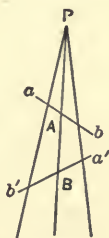

Fig. 53.

121. Force Outside a Charged Sphere. — The force or electric intensity at any point outside a charged sphere, over which the distribution is uniform, is the same as if the entire charge were collected at its centre. This proposition admits of simple demonstration.

Let P be the point at a distance D from the centre of the sphere (Fig. 54). Let σ be the surface density, and

let s be the area of a very small element of the surface at the point B . The quantity on it is $s\sigma$, and if ρ is the distance PB , the force at P due to this element of the charge is $s\sigma/\rho^2$. Since the entire surface of the sphere is

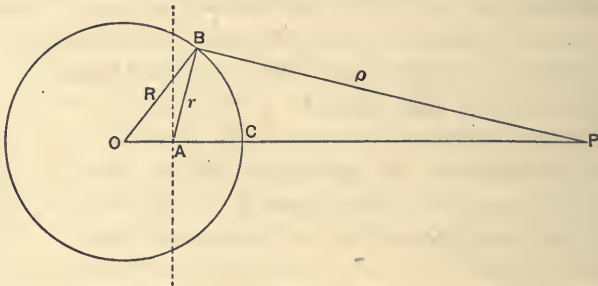

Fig. 54.

symmetrical with respect to the line PO , the resultant of all the forces due to the several elements of the charge must be along PO . The component of the force $s\sigma/\rho^2$ along this line is

$$f = \frac{s\sigma}{\rho^2} \cos a,$$

where a is the angle OPB .

Draw BA , making the angle ABO equal to a . Also let ω be the solid angle which the area s subtends at A . The projection s' of the area s at right angles to AB subtends the same angle ω at A . Since the angle between s and s' is a (Fig. 55), we may write

$$s' = \omega r^2 = s \cos a,$$

or

$$s = \frac{\omega r^2}{\cos a}.$$

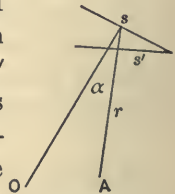

Fig. 55.

Substituting this value of s in the expression for f , and

$$f = \frac{\omega r^2}{\rho^2} \sigma.$$

The triangles OBA and OBP are similar, and therefore

$$\frac{r}{\rho} = \frac{R}{D},$$

where D is the distance PO . Hence by substituting above,

$$f = \frac{R^2}{D^2} \sigma \omega.$$

This is the force due to a single element of the surface. For the entire surface the force is the sum of the small forces due to all such elements, or

$$F = \frac{R^2}{D^2} \sigma \Sigma \omega.$$

The expression $\Sigma \omega$ is the entire solid angle subtended by the surface of the sphere at any point within it, and this is 4π . Hence

$$F = \frac{4\pi R^2 \sigma}{D^2}.$$

But $4\pi R^2 \sigma$ is the product of surface of the sphere and the surface density, or the whole charge on the sphere, and D is the distance between the point P and the centre of the sphere. Therefore the expression for F is precisely the same as would be obtained for the force at P if the whole charge were at the centre of the sphere. It is worth noting that this demonstration applies equally well to the force of gravity due to a thin shell of matter, when the shell is of uniform thickness and density.

122. Force very near a Charged Sphere.—If the point P in Fig. 54 is made to approach the sphere, the point A also moves toward the surface to meet P ; and when P is at the surface D equals R and

$$F = 4\pi\sigma,$$

or the electric intensity is independent of the size of the

sphere, and is numerically equal to 4π times the surface density. This result, which is known as Coulomb's Law, requires modification when the sphere is surrounded by some other dielectric than air. It applies to any charged conductor. Since there is no force inside the sphere, the change of force in passing from a point just outside to the interior is $4\pi\sigma$.

If a plane perpendicular to PO be drawn through A , it will divide the spherical surface into two parts, each of which subtends at A the same angle 2π . Hence half the force is due to the charge to the right of this dividing plane, and the other half to the charge to the left of it. At the surface of the sphere one of these charges is contained on an infinitesimal area, and the other is the charge on all the rest of the sphere. The force is then the same as that due to a plane of indefinite extent, tangent at C and charged on both sides.

123. Force near a Charged Plane Conductor (Th., 262).—Imagine a plane of indefinite extent charged

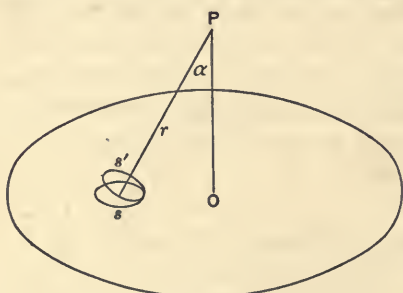

Fig. 56

positively on one side to a density σ . Let P be the point at which the force is to be determined (Fig. 56), and PO the normal to the plane. Let s be any small surface on the plane, and ω the solid angle which it subtends at P . It is the solid angle at the apex of the

cone made by drawing lines from the boundary of s to the point P . The force at P due to the charge on this

element is $s\sigma/r^2$, and the component of this force along the normal PO is

$$f = \frac{s\sigma}{r^2} \cos a,$$

where a is the angle between the normal and the axis of the cone.

As in Art. 121, the orthogonal section of the cone $s' = \omega r^2$ and

$$s' = \omega r^2 = s \cos a.$$

Therefore
$$s = \frac{\omega r^2}{\cos a}.$$

Substituting in the equation for f , we have

$$f = \sigma \omega.$$

Since the resultant of all the forces due to the elementary charges is along the normal, the total intensity of the force at P is

$$F = \sigma \Sigma \omega.$$

But $\Sigma \omega$ is the solid angle subtended at P by a plane of indefinite extent, and this is the angle subtended by a whole hemisphere, or 2π . Therefore

$$F = 2\pi\sigma.$$

In the C.G.S. system the force is in dynes.

If the plane is limited and the point P indefinitely near it, the force is again $2\pi\sigma$.

Since the force on a $+$ unit above the plane is directed upward and below the plane downward, in passing through the plane the force changes by the quantity $4\pi\sigma$.

PROBLEMS.

1. Two equal small balls are charged with $+30$ and -6 units of electricity respectively. Find the mutual force between them when their centres are 6 cms. apart, before and after contact with each other.

2. A charge of 100 units is applied to a sphere of 10 cms. radius. What is the surface density?

3. In the last problem, what is the value of the electric intensity at the surface?

4. Two small balls, each one gm. in mass, are suspended from the same point by silk fibres 490 cms. long. If g is 980 dynes, show that the balls will diverge to a distance of one cm. if each is charged with one unit of electricity.

5. Two small spheres 10 cms. apart are charged with $+5$ units and -5 units respectively. Find the direction and magnitude of the force acting on a $+1$ unit at a distance of 10 cms. from both charges.

CHAPTER XII.

ELECTRIFICATION BY INFLUENCE.

124. **Fundamental Phenomena.** — A charged conductor exerts influence, or acts inductively, on all neighboring bodies. If it be positively charged, lines of electric force start from it and proceed to an equal negative quantity on adjacent bodies. The influence is exerted along these lines of force, or lines of tension.

Let an insulated sphere *A* (Fig. 57), charged positively, be placed near an insulated cylindrical conductor *B*. Light

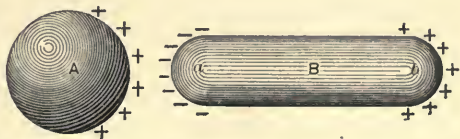

Fig 57.

pith-balls suspended by linen threads at either end of *B* will diverge, and the nearer *A* approaches *B* the wider the divergence, unless the charges on *A* and *B* unite by a spark across the air-gap. If *A* and both ends of *B* be now examined by means of a proof-plane and an electroscope, it will be found that the charge on *A* has been redistributed, so that the surface density on the side toward *B* is greater than on the remote side; also the end *a* of the cylinder will be found to be negatively charged, the central portion will be neutral, and the end *b* will be positively charged. The density at *b* will be less than at *a*, and the neutral line will be somewhat nearer *a* than *b*.

When A is removed or discharged by connecting with the earth, all signs of electrification on B disappear. The separation of the positive and negative charges on B through the influence of the charge on A is called electrostatic *induction*, or electrification by *influence*.

125. Charging by Influence. — If the conductor B be connected with the earth while under the inductive influence of A , the repelled charge will pass off, leaving only the attracted electricity. This latter charge is said to be “bound” in distinction from the “free” charge which goes to the earth. If now A be removed while B remains insulated, the charge on the latter will be distributed over the whole conductor, and B is said to have been charged by influence or induction.

The electrification of B represents energy. Work has been done in removing A against the attraction of the — charge on B . If B uninsulated were to be brought up to A from a distance, and then removed after insulating it, the work done by mutual attraction during the approach would be less than that done against the attraction during the withdrawal, because the acting charge on B in the latter movement remains constant, while during the approach of B to A the charge on B increases from nothing to the maximum. The working force is then less during the approach than during the recession.

If when the — charge has been insulated on B the positive on A is discharged to earth, the electrification of B still represents energy. The energy of the discharge of A under these conditions is less than that required to charge it when removed from inductive action on other bodies. This will be better understood after studying the relation between energy and potential.

126. Electrification with like Charges by Influence.

— When a body is charged by influence as explained in the last article, the repelled charge always becomes free, and the conductor is charged so that the inducing and the induced charges are of opposite sign. In this case provision must be made for drawing off the repelled charge.

It is quite possible, however, to provide for the removal of the attracted charge, so that the conductor under influence shall remain charged with electricity of the same sign as the influencing charge. Imagine the conductor *B* provided with a row of sharp points at the end *a* (Fig. 58), and let a circular glass plate

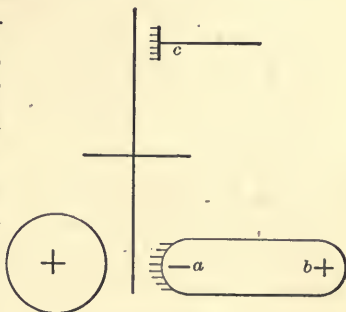

Fig. 58.

be revolved with its edge between *A* and *B*. The attracted charge will then acquire so great a density on the points that they will discharge it on the revolving plate. If another row of points *c*, connected with the earth, be placed opposite the same side of the glass plate, but out of the inductive action of *A*, then as the plate revolves it will give up to *c* the negative charge acquired at *a*, and *c* will convey it to the earth. In this way *B* is left with a + charge. Work is done in turning the glass plate against the attraction of the unlike charges on it and *A*.

127. Attraction due to Induction. — The simple facts of induction furnish an explanation of the attraction between electrified and unelectrified bodies. The induced charge of opposite sign always accumulates on the part

of the conductor nearest the inducing charge, while the repelled charge retires to the most distant parts of the conductor, or goes to the earth if a conducting path is furnished.

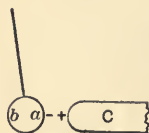

Fig. 59.

If an excited glass rod *C* (Fig. 59) be presented to an uncharged pith-ball suspended by silk, negative electricity will be induced on the pith-ball at *a* and positive at *b*. Since the former is nearer *C* than the latter, the attraction will prevail over the repulsion, and the pith-ball will on the whole be attracted. If the pith-ball be touched while under induction, the repelled + charge will go to earth and the attraction will be increased.

If the pith-ball be slightly charged positively, then the resultant action on it will be the algebraic sum of the repulsion due to this charge, and the attraction due to induction. Repulsion will generally be first observed as the pith-ball is brought near *C*, but at smaller distances the inductive attraction will prevail. Repulsion is therefore a better test of an independent charge than attraction.

128. Relation between the Induced and the Inducing Charges. — The charge on a conductor under induction can never exceed the inducing charge. It must be borne in mind that the bound electricity is held by attraction exerted along lines of force. If all the lines from the inducing charge proceed to the induced charge, the two will then be equal. Generally only a portion of the lines are common to the two charges, while the remainder go to other bodies. If a charged ball be nearly surrounded by a hollow conductor (Fig. 60), all the lines of force from the ball *A* will



Fig. 60.

end in the induced charge on the enclosure. No sensible portion of them will escape through the small opening. A $-$ charge will then spread over the interior of B , equal in amount to the $+$ charge on A .

This case furnishes an exception to the general law that the charge is confined to the outside of a conductor; but it is held on the inside by inductive action from A , or is a bound charge. If B should be insulated while under induction and A then removed without contact with B , the $-$ charge on B would become free and would spread over the exterior.

129. Faraday's Ice-pail Experiment.—Faraday employed a pewter ice-pail as a convenient hollow conductor to test the relative values of the induced and inducing charges. A is a section of a well-insulated pail (Fig. 61). The outside is connected with a gold-leaf electroscope E . A charged ball C is let down into the pail by means of a silk thread. As soon as it enters the pail the gold leaves begin to diverge, and the divergence increases till the ball reaches a certain depth. Beyond this point the divergence remains constant. Evidently the divergence increases up to the point where all the lines of influence from the ball run to the negative charge on the inside of the pail. With the ball still lower, the distribution of the charge, both on the inside and the outside of the pail, may be changed, but the quantity remains the same.

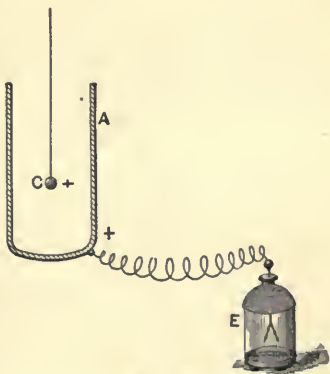

Fig. 61.

If now the ball be allowed to touch the pail, not the slightest change in the divergence of the gold leaves can be detected. The meaning is that the free positive charge on the outside of the pail, when the ball is acting inductively on it, is exactly the same as the charge communicated by the ball on making contact. The inducing and the induced charges are therefore equal.

The experiment was varied by touching the pail while under influence from the ball. The gold leaves collapsed. On withdrawing the ball they again diverged to the same extent as before, but with a negative charge. If then the charged ball were replaced and made to touch the pail, all signs of electrification disappeared, or the induced negative charge was exactly equal to the positive conveyed by the ball.

Faraday extended these experiments by placing four cylinders or ice-pails one within another, but all separately insulated. The entrance of the ball caused a divergence of the leaves of the electroscope connected with the outer pail. No change in the divergence could be detected when the cylinders, while remaining insulated from the earth, were connected together one after another, showing that the successive inductions resulted in separating equal quantities of positive and negative electricity on each pail, alternating with each other, — the inside of each pail being charged negatively and the outside positively.

130. The Electrophorus. — The electrophorus is a simple instrument, invented by Volta, for the purpose of obtaining an indefinite number of small charges by influence from a single charge produced by friction. It consists of a metal base or sole, a dielectric disk of resinous material or vulcanite fitting the base, and a cover provided

with an insulating handle (Fig. 62). The form shown in the figure is so made that the handle can be screwed either to the cover or the base. In the middle of the disk is a brass stud screwed into the base and connecting the base and cover when the latter is applied to the disk.

To use the electrophorus the dielectric must first be electrified by striking with a cat's skin. A chamois skin will answer, but cat's fur is better. This gives to the hard rubber disk a — charge, and if it is warm and dry it will retain its charge for some time. The cover is then placed on the disk, touched with the finger or to the sole, if the instrument is not provided with the brass stud to connect the two metal plates, and is then lifted by the glass handle. It will be found to be charged positively to such a degree that a spark may be obtained from it by presenting the knuckle. The operation may be repeated an indefinite number of times without removing any appreciable part of the original charge from the vulcanite, since the cover touches it at a few points only.



Fig. 62.

The operation of the instrument is easily explained by the principle of influence. When the cover is placed on the excited disk, it is really insulated from it and is powerfully acted on inductively. A positive charge accumulates on its lower surface and a free negative one on the top. The latter is removed from the cover when touched by the finger or to the base. When the cover is lifted by the glass handle the positive charge on it is separated from the negative on the disk and becomes free. No

part of the original charge has been removed; that remains on the vulcanite disk to serve for the repetition of the operation. It is slowly dissipated if the air is damp or if the vulcanite is not dry.¹

131. Energy of the Successive Charges. — Since the successive charges on the cover in the normal use of the

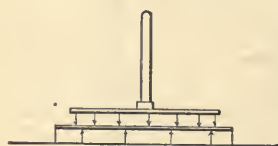

Fig. 63.

electrophorus are not derived from the disk, it is important to explain the source of the energy represented by them; for electrification is a form of energy and cannot be produced without the expenditure

of energy in some other form.

When the cover is on the disk and the — charge has been removed, it is held down to the disk by the lines of force running from the positive on it to the negative on the disk. A few lines also run from the base to the disk, as shown in Fig. 63.



Fig. 64.

Now to lift the cover without discharging it,

¹ It is possible to obtain six successive sparks from the electrophorus by one application of the cover. For this purpose the base must be placed on an insulating stand and the cover must not come into electric contact with it. The several operations are as follows:

- (1) Beat with cat's skin and remove the repelled — charge from the base.
- (2) Apply the cover and remove from it the free — charge.
- (3) The induction on the cover diminishes the influence of the — charge of the disk on the base and releases part of the + charge. In other words, while the charge on the vulcanite is engaged in holding the + charge on the cover, it lets go some of the positive on the base, which may be removed.
- (4) The last operation allows greater induction on the cover. Bring cover and base into contact and a spark will pass.
- (5) Lift the cover. The minus charge on the disk again attracts positive on the base and releases negative, which may be removed.
- (6) Discharge the positive on the cover.

these lines of force must be stretched and broken. As the cover is withdrawn fewer lines run from it to the disk and more come from the base, as illustrated in Fig. 64. Hence to lift the cover work must be done against the force represented by the tension of these stretched lines, in addition to the work done against gravity. This extra work is equal to the energy of the charge.

132. Lord Kelvin's Water-dropping Accumulator.

— This interesting device illustrates the accumulation of electric charges by influence, and serves as an introduction to the continuous electrophorus, or influence machine, about to be described.

A and B are two insulated hollow conductors electrically insulated and called *inductors* (Fig. 65); A' and B' are two others called *receivers*, all shown in section. C and D are pipes from which water issues in drops at the middle of A and B . These conductors are initially charged with very small positive and negative charges.

The operation is as follows: As drops issue from the two nozzles they are influenced inductively, since they are not completely surrounded by the hollow inductors. When the drops fall, those in A have a $-$ charge and those in B a $+$ one. The two lower cylinders or receivers contain funnels which receive the drops and their charges, thus increasing the electrification of the two sets of conductors. The effect is cumulative, and the electric density increases till

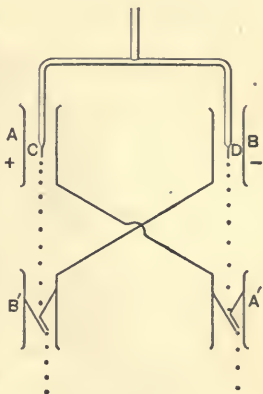

Fig. 65.

sparks pass between parts of the apparatus, or the water-drops are scattered about over the edges of the receivers. It is essential that the two streams shall be discontinuous or be broken into drops.

The energy of the charges is derived from the potential energy of the falling water. The drops are attracted upwards and fall more gently than they would if free. Their loss in potential energy in falling from inductors to receivers is therefore less than that corresponding to the difference of levels, and this difference in energy is the energy of the charges which they convey.

133. The Holtz Influence Machine (Th., 65; B., 584).
—It was long ago seen that if the principle of the elec-

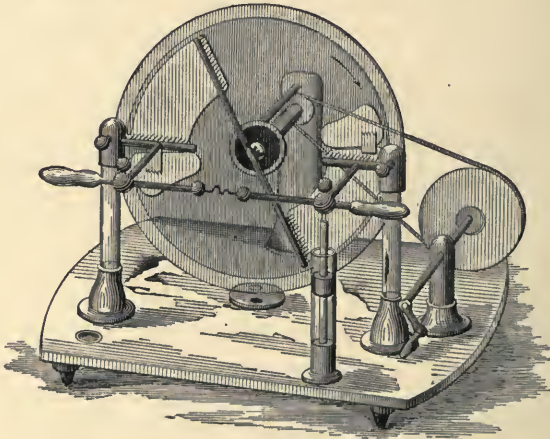

Fig. 66.

trophorus could be made to act continuously by mechanical means, an influence machine could be constructed which would be superior to the old method of producing electrification by friction. This has been accomplished by several

inventors, and frictional machines have in consequence gone out of use.

The first successful influence machine was the one made by Holtz in 1865. Inasmuch as it has been superseded by others having the advantage of being self-exciting, a brief description must suffice.

A thin vertical glass plate revolves very near another of somewhat larger diameter and fixed (Fig. 66). The fixed plate has two openings or windows cut through at the ends of a horizontal diameter. Extending from these openings on the back of the plate are two long sectors of paper, provided at the windows with tongues or notched edges pointing toward the back of the revolving plate. These sectors constitute the field plates or armatures. They extend about 60° , and opposite their extreme ends in front are two metal combs connected by a diagonal neutralizing rod, running along a diameter. The two other combs in front of the rotating plate and just opposite the windows are collecting combs connected with the two discharge balls.

To explain the action it is best to adopt the diagrammatic method of Bertin, in which the

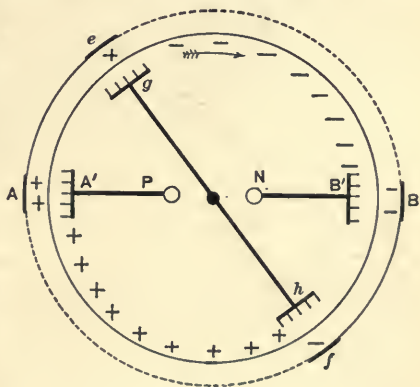

Fig. 67.

two plates are shown as two concentric cylinders (Fig. 67). *A* and *B* are the field plates, *g* and *h* the neutralizing brushes, and *A'* and *B'* the collecting combs joined to the balls *N* and *P*, between which the discharges take place.

To start the machine N and P are brought together, and one paper sector, as A , is feebly excited positively by contact with the charged cover of the electrophorus, or by induction from excited vulcanite. As the glass disk is revolved the induction between e and g causes the latter to discharge negative on the front of the plate, while positive is repelled to the other comb h and is there discharged on the plate. When the negative comes round to the window at B , it acts inductively on the paper armature B and on the comb B' . Positive is discharged on the plate from both of these, leaving B negatively excited. At the same time the + discharge on the plate at h is carried around to the window at A , where it attracts - from both A and A' , leaving both +. The continuation of this action results in the intense excitation of the two armatures or field plates. It will be observed that the arrangement is such as to carry away in each case the attracted charge, or the parts are charged by influence in such a way that the inducing and the induced charges have the same sign.

Turning now to the combs A' and B' , the balls N and P may be separated, and the induction from A and B and from e and f keeps the upper half of the revolving plate, front and back, charged with - and the lower half with + electricity. The charges on the front are carried off by the combs A' and B' and unite by means of a spark between N and P . Small Leyden jars (152) are connected with one or both of the discharge rods for the purpose of collecting a greater quantity for each discharge.

134. The Toepler (Voss) Machine (Th., 59; B., 588).

— The only advantage possessed by this form of machine is that it is self-exciting and will work in a damp atmosphere when the Holtz will not. There are no windows in

the fixed plate, and underneath the paper armature c and c' are three disks of tin foil connected by a narrow strip of the same material, as shown in Fig. 68. To the front of the revolving plate are pasted at equal distances six or eight small tin-foil disks with a low metal button in the centre of each. The tin-foil disks on the fixed plate are electrically connected to bent metal rods, as shown at a

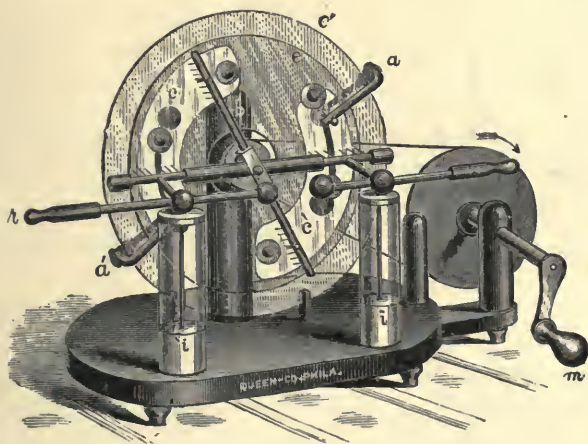

Fig. 68.

and a' These carry in front tinsel or fine wire brushes, which touch the metal buttons on the revolving plate as they pass under them. The diagonal neutralizing rod has tinsel brushes in addition to the combs. The small disks on the front plate are rotating carriers, and each is charged inductively by being placed in momentary connection with one under opposite electrical influence. At the same time the points on the neutralizing rod discharge on the revolving plate, as in the Holtz machine.

The action may be explained by the aid of the diagram (Fig. 69). The neutralizing brushes are set so as to connect the carriers, as *b* and *e*, just before they pass beyond the influence of the armatures *A* and *B*. They thus acquire

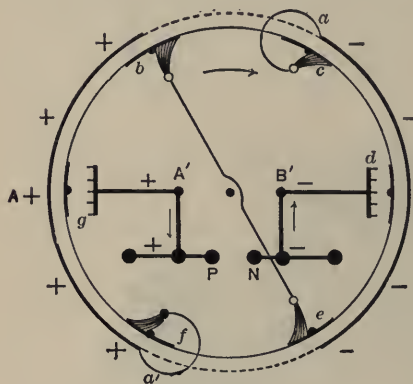

Fig. 69.

by influence — and + charges respectively. Passing on to the positions *c* and *f*, they are brought into momentary contact with the armatures by *a* and *a'*, and deliver up to them their small charges. This action is repeated by each pair of carriers, however small may be the initial excitation of

A and *B*. In this way *A* becomes more highly + and *B* more highly -. When the carriers are highly charged they do not give up their entire charges to the armatures, and the collecting combs *A'* and *B'* receive the residue in addition to the charges carried on the glass. There is usually enough excitation by friction or by contact of dissimilar substances to start the machine.

135. **The Wimshurst Machine** (Th., 61; B., 589). — Wimshurst's influence machine is the simplest of all in construction, and is very effective. Both glass plates rotate, but in opposite directions. They are provided with a number of narrow tin-foil sectors arranged radially on the outer sides (Fig. 70). These strips act both as carriers and as inductors. Across the front is fixed a diagonal

conductor, armed at both ends with tinsel brushes. Across the back is another rod at right angles to the one in front. Its brushes touch the metal sectors on the back plate. Collecting and discharging apparatus is added to utilize the charges produced. These must be well insulated from

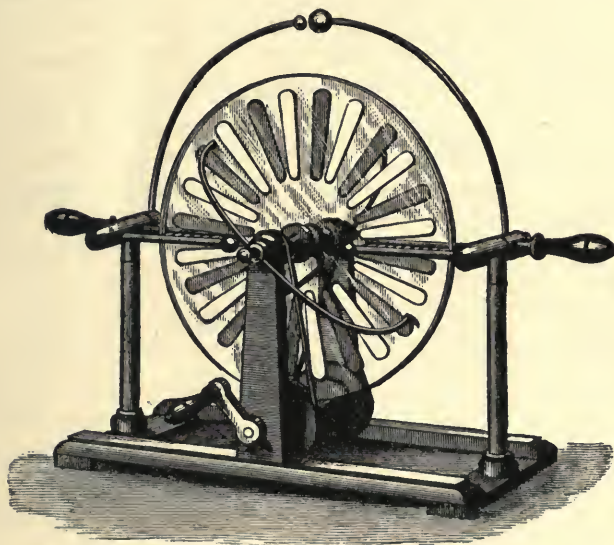

Fig. 70.

each other on the two sides of the machine. Leyden jars may be used as in the other machines.

The action will be understood from the diagram (Fig. 71), in which again the two plates are represented as sections of concentric cylinders, after Bertin and Thompson. The inner cylinder represents the front plate, and the outer one the other. Suppose a back sector to receive a slight charge. As a front sector *a* passes the outer charged one, it is acted on inductively and an electric displacement

takes place along the conductor, leaving *a* slightly charged negatively, while *b* receives a corresponding + charge. These small charges will be carried forward opposite *c* and *d*. Here *c* and *d* are touched by the brushes at the back, and at the same instant are under the influence of the - and + charges on *a* and *b* respectively. They will, therefore, receive + and - charges, and will convey them in the opposite direction to the motion of the front sectors. All the sectors will thus become highly charged by the cumulative effect of reciprocal

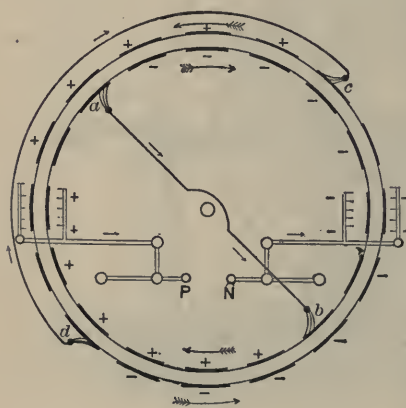

Fig. 71.

influence, the front sectors on the upper half carrying - charges from left to right, and the back sectors carrying + charges from right to left. On the lower half of the plates a similar but inverse set of operations occurs. Each metal sector is alternately under influence and acting as an inductor. By this

double action - charges are continually conveyed by both plates to the right and + ones to the left. The collecting combs draw off these charges and convey them to the discharging balls.

In all influence machines the plates are turned in opposition to the attractions between unlike electrifications. Hence, more work is done in turning the plates when the machine is in operation than when it is not excited.

The stress between the fixed and movable parts, or between parts moving in opposite directions, is an opposing

stress, or tends to turn the plates in the direction opposite to their proper motion as a generator. All these machines are therefore reversible, or may be rotated backwards as motors, by communicating to their armatures a continuous supply of electricity.

CHAPTER XIII.

ELECTRICAL POTENTIAL.

136. Definition of Potential.—The term *Potential* was introduced by George Green, of England, in 1828, but his theorems connected with it remained unknown till most of them had been rediscovered by Lord Kelvin, Clausius, and others. This function plays a highly important rôle in the study of electrical phenomena. It is intimately connected with the law of Conservation of Energy, and has had an important bearing on the progress of electrical theory and practice.

Consider two similar electrical charges left to themselves. The mutual repulsion between them will cause them to move apart till they are beyond each other's influence. The *mutual potential energy* of such a system in any given position is the work done by their mutual repulsion in separating them to an infinite distance, or in conveying one of the charges to the boundary of the field produced by the other.

The *potential* at any point, due to a given positive charge, is the mutual potential energy between this charge and *unit quantity* of positive electricity placed at the point. It is the same as the work which must be done on a positive unit of electricity in bringing it up to the point from an infinite distance, or from the boundary of the field of force due to the given charge. If the potential is assumed

to be zero at some place chosen as a standard of reference, then any point will have a positive potential if work must be done in bringing a positive charge from the zero point to it, and negative if work is required to convey a positive charge from it to the zero point. For convenience the potential of the earth is usually taken to be the arbitrary zero. Positive electricity, left to itself, tends to flow along lines of force toward points where the potential is lower; negative electricity travels toward higher potentials.

137. Difference of Potential. — Consider two points, A and B , and let the potentials at these points be represented by V_1 and V_2 respectively. Then since work equal to V_1 is required to convey a unit of + electricity from an infinite distance to the point A , and a quantity V_2 from an infinite distance to the point B , it is obvious that the work done by the electrical forces in displacing a positive unit of electricity from the one point to the other is $V_1 - V_2$. The work is independent of the path followed in going from A to B ; otherwise it would be possible, by making a quantity of electricity circulate between A and B by suitable paths, to produce an infinite quantity of work without an equivalent expenditure.

138. Equipotential Surfaces. — An equipotential surface is the analogue of a level surface. It is a surface perpendicular at every point to the direction of the force; or, in other words, all the lines of force which it encounters are normal to it. There is then no component of force along an equipotential surface, and no work is spent in displacing any quantity of electricity on such a surface. The potential at all points of an equipotential surface is therefore the same.

Consider two such surfaces S_1 and S_2 , whose potentials are V_1 and V_2 . The work which must be done in displacing the unit quantity from the one surface to the other is then the difference of the two potentials, or $V_1 - V_2$. It is independent of the path travelled and of the position of the point of departure and the point of arrival on the two surfaces. If a quantity q units is conveyed from one surface to the other, the work required is q times as great as for one unit, or $q(V_1 - V_2)$. The numerical measure of the electrical work is therefore a product of two factors, one of them a potential difference and the other a quantity of electricity. If the potentials of the two surfaces differ by unity, then one erg of work must be spent in conveying the unit quantity from one surface to the other.

139. Expression for Force in Terms of Potential.—

Let there be two equipotential surfaces, S and S' , very near together (Fig. 72), and let their potentials be V and V' . Let F be the constant force along a normal between P and P' equivalent to the variable one between the two surfaces. If n is the distance PP' , the work done by the force in conveying a unit quantity from one surface to the other is $F \times n$. We have then

$$Fn = V - V',$$

or

$$F = \frac{V - V'}{n}.$$

The electric intensity along a line of force is therefore the rate at which the potential diminishes per unit length along that line.

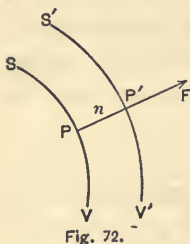

Reduced to limits, or to infinitesimal values,

$$F = -\frac{dV}{dn}.$$

This expression is the strength of field at any point. The minus sign indicates that the positive direction of the force is the direction in which the potential diminishes. In general the intensity of the force *in any direction* is the rate of diminution of the potential in that direction.

140. Equilibrium of a Conductor. — When a charge of electricity is imparted to a conductor, it at once distributes itself over the surface and comes to equilibrium. The surface of the conductor is therefore an equipotential surface. Moreover, since there is no force inside a conductor, due to a charge on its surface, there is no difference of potential throughout its entire volume, since force is the rate of variation of potential. Hence all points of a charged conductor have the same potential.

The surface of an insulated conductor under the influence of a charged one is an equipotential surface, because there is no electric flow along it. This equality of potential in the presence of an influencing + charge is brought about by the negative charge on the near end *a* (Fig. 57) and the positive on the remote end *b*. The potential at *a*, due to the + charge on *A*, is higher than at the more distant point *b*; but the negative charge near *a* lowers the potential of the nearer half of the cylinder, and the positive near *b* raises the more distant half to the same level as *a*. If now the cylinder be connected with the earth, it will be reduced to the same potential as the earth, or to zero. The cylinder will then remain charged negatively, but its potential will be zero. The positive potential due to *A* and the negative due to its own charge then everywhere equal each other,

and the resultant is zero. It is evident that surface density and potential are not in any sense the equivalents of each other.

141. Potential equals $\sum \frac{q}{r}$. — Consider the potential at A , at a distance r from an element q of the charge at O

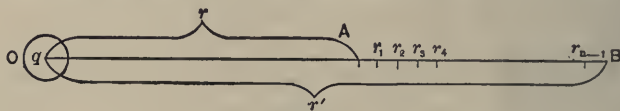

Fig. 73.

(Fig. 73). Let B be at a distance r' from O . Let the distance between A and B be divided into n very small elements, so that the points of division are distant $r_1, r_2, r_3,$ etc., from O .

Then the force at r is q/r^2 , the force at r_1 is q/r_1^2 , etc.

If r and r_1 are very nearly equal, we may put without sensible error q/rr_1 as the equivalent force which will do the same amount of work as the variable force between the two adjacent points at r and r_1 . This force is smaller than the first expression above and larger than the second one.

Then to carry unit charge from r_1 to r work must be spent equal to

$$\frac{q}{rr_1} (r_1 - r) = q \left(\frac{1}{r} - \frac{1}{r_1} \right).$$

Similarly the work between r_2 and r_1 is $q \left(\frac{1}{r_1} - \frac{1}{r_2} \right)$.

.

From r' to r_{n-1} the work is . . . $q \left(\frac{1}{r_{n-1}} - \frac{1}{r'} \right)$.

The whole work done in transferring the unit quantity from B to A is the sum of all these elements of work; it is evident that on adding, all the terms containing the r 's cancel out except the first and the last, or

$$\text{Work from } B \text{ to } A = q \left(\frac{1}{r} - \frac{1}{r'} \right).$$

Next suppose the point B moved off to an infinite distance. Then $1/r'$ becomes zero, and

$$\text{Work from infinity to } A = \frac{q}{r}.$$

But by definition this is the potential at A , since it is the expression for the work spent in bringing unit quantity of electricity from an infinite distance to the point. There will be similar expressions for the several elements of the charge, and the resulting potential at A will be the algebraic sum of the potentials due to the several elements, or

$$V = \frac{q'}{r'} + \frac{q''}{r''} + \frac{q'''}{r'''} + \dots = \Sigma \frac{q}{r}.$$

142. Potential of a Sphere. — Let the sphere have a charge Q . Every element q of this charge is at a distance r from the centre of the sphere; and the potential at the centre due to this element is q/r , where r is the radius. The potential due to the entire charge is then

$$\Sigma \frac{q}{r} = \frac{1}{r} \Sigma q = \frac{Q}{r}.$$

But as all points of a conductor in equilibrium have the same potential, the potential of every point of a sphere due to a charge Q is Q/r .

Since a charge, uniformly distributed over a sphere, acts on external points as if it were collected at its centre, the

potential at any point outside of the sphere and distant d units from its centre is Q/d .

143. **Electrometers.** — An electrometer is an instrument designed to measure differences of electrostatic potential. Its indications depend on the attraction

between an electrified and an unelectrified plate, or on the action between two conductors electrified to different potentials. Sir Snow Harris was the first to construct such an instrument.

It was made like a balance, with a small pan P (Fig. 74) on one end of the beam, and a small round disk d on the other, just above a fixed insulated plate a . When a was electrified it attracted d , and the attraction was counterbalanced by weights in the pan P . But the plate d was not protected from inductive influence, and no precise absolute measurements involving the

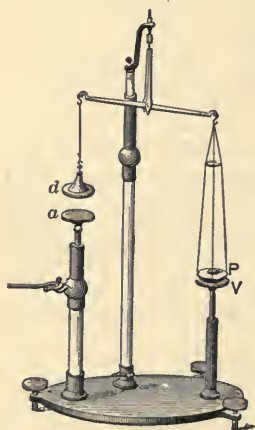

Fig. 74.

dimensions of the disks could be made, because the surface density was not uniform over the whole disk (see Fig. 47), but was greatest at the edges, where the lines of force were not parallel to one another, but curved outward. This difficulty was overcome by Lord Kelvin, to whom we are indebted for modern electrometers.

The essential addition of Lord Kelvin is the guard ring shown in Fig. 75. The suspended disk C fits, without contact, an aperture in the guard ring A , to which it is electrically connected. The disk C is the only part of the area utilized; the surface density over it is uniform and the lines of force between it and B are parallel.

144. **Attracted-disk Electrometer.** — In the attracted-disk electrometer the attraction between two parallel disks at different potentials is counterbalanced by a weight D (Fig. 75). The disk C , when in position, is adjusted so that its lower face is as nearly as possible in the same plane with the lower surface of the guard ring A . The lever L is pivoted on a torsion wire stretched between two insulated pillars EE . A lens G is mounted so as to observe an index hair at the end of the lever L relative to two dots on the plate F . The plate C is in position when the hair is between the two dots. The disk B is insulated and can be raised or lowered by means of a micrometer screw not shown.

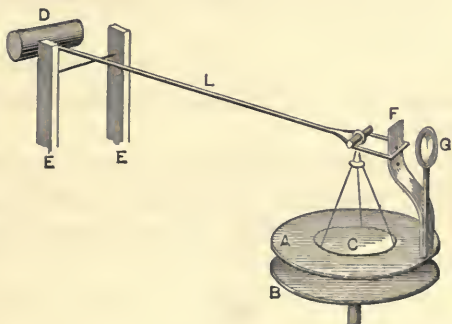

Fig. 75.

The counterpoise D is such that when

B and C are at the same potential, the index hair rises above the sighted position. The force required to bring the hair down to the sighted position is determined by placing a small weight on C and a "rider" on the arm L . But when B and C are at different potentials, the attraction between them draws C down; the plate B is then adjusted in height till the index hair comes to the sighted position. The attraction between the plates is then equal to the force of gravity on the weights previously determined.

145. **Theory and Use of the Instrument.** — Let V_1 be the potential of the movable disk C , which is charged

positively to a surface density σ ; and let V_2 be the potential of the plate B . Since the lines of force between the two plates are parallel, the surface densities of the plates are of opposite sign and numerically equal. Then the electric intensity, or the force on a positive unit, between the plates is $4\pi\sigma$, an attraction of $2\pi\sigma$ by the fixed plate, and a repulsion of $2\pi\sigma$ by the movable plate. The two plates are equipotential surfaces and $V_1 - V_2$ is the work which must be done on a positive unit to convey it from C to B . Therefore, since work equals the product of force and distance,

$$V_1 - V_2 = 4\pi\sigma D,$$

where D is the distance between the fixed and movable plates.

The electric intensity at C due to the charge on B is $2\pi\sigma$. If S is the area of the movable plate C , the charge on it is $S\sigma$. Therefore the normal mechanical force pulling the plate downward is

$$F = 2\pi\sigma \times S\sigma = 2\pi\sigma^2 S.$$

Whence
$$\sigma = \sqrt{\frac{F}{2\pi S}}.$$

By substitution in the equation above we have

$$V_1 - V_2 = D \sqrt{\frac{8\pi F}{S}}.$$

Now F is known from the weights previously applied, and S can be measured; $\sqrt{\frac{8\pi F}{S}}$ is therefore the constant of the instrument. If F is measured in dynes, S in square centimetres, and D in centimetres, the measurement of D determines the difference of potential in absolute measure.

Practically there is great difficulty in measuring D with sufficient accuracy. Hence a different method of measurement is adopted. The plate B is kept charged to a definite potential, and the disk C is first connected to the earth, whose potential is zero, and B is adjusted in height till C is in the sighted position; a reading of the micrometer is then taken. The conductor to be tested is then connected with C and another adjustment of B is made and a reading is taken. Let the distances between B and C for the two adjustments be D and D' . Then we have for the potential of C

$$V = (D - D') \sqrt{\frac{8\pi F}{S}}$$

It is then necessary to determine the difference $D - D'$ only, and this can always be done with great accuracy.

In the most elaborate modern instruments the disk C is suspended by small springs, and both are protected from inductive influence by a cylindrical metal cover.

146. The Quadrant Electrometer (J. J. T., 98).—The force F measured by the instrument just described

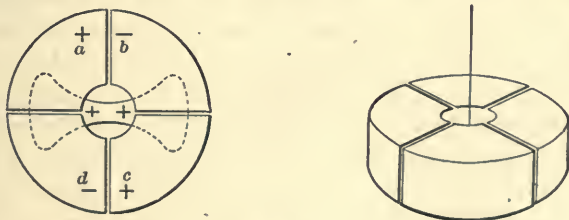

Fig. 76.

varies as the square of the potential difference. When this potential difference diminishes, the force falls off very rapidly. For this reason the instrument is not suitable for

the measurement of very small potential differences; for these Lord Kelvin devised the quadrant electrometer.

The most essential parts are the cage, or quadrants, and the needle (Fig. 76). The needle, a thin oblong piece of aluminium with broad rounded ends, shown in dotted outline in the figure, is suspended by a very fine wire or fibre so as to turn in a horizontal plane around a vertical axis. It swings centrally within four quadrants, *a*, *b*, *c*, *d*, which together form a short hollow cylinder with parallel ends. Opposite quadrants, as *a* and *c*, and *b* and *d*, are connected electrically. The needle is supported on a stiff wire carrying a mirror *M* (Fig. 77) at the top, and connecting at the bottom with the jar *B* by a fine platinum wire dipping into sulphuric acid.

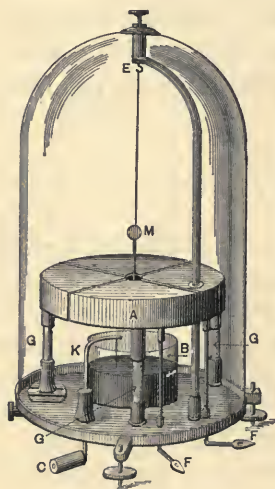

Fig. 77.

Consider the needle charged positively. If all the quadrants are at the same potential, the needle will take a position depending only on the torsion of the suspending fibre; but if *a* and *c*, for example, be at a higher potential than *b* and *d*, the forces acting on both ends of the needle form a couple which will turn it opposite to watch-hands. If the potential of *a* and *c* is lower than that of the other pair of quadrants, the needle will turn the other way; it will come to rest when there is equilibrium between the two couples, the one due to the electrical forces, and the other to the torsion of the suspending fibre.

Let V_0 denote the potential of the needle, V_1 and V_2 the

potentials of the two pairs of quadrants, and θ the angular deflection of the needle; then the equation of equilibrium is

$$\theta = C(V_1 - V_2) \left\{ V_0 - \frac{1}{2}(V_1 + V_2) \right\}, \dots (a)$$

where C is a constant.¹

If V_0 be very large in comparison with the other potentials, the term $\frac{1}{2}(V_1 + V_2)$ may be neglected in comparison with it, and

$$\theta = C(V_1 - V_2) V_0, \dots (b)$$

or the deflection is proportional to the difference of potential to be measured. The sensibility is proportional to V_0 , the potential of the needle.

When the needle is thus charged from a source independent of the quadrants, the instrument is said to be used *heterostatically*.

147. Quadrant Electrometer used Idiostatically. — For the measurements of larger potential differences the needle is connected with one pair of quadrants, so that there is only one source of electrification, and this use of the electrometer is called *idiostatic*. We may then put V_0 equal to V_1 , and equation (a) becomes

$$\theta = C(V_1 - V_2)^2,$$

or the deflection of the needle is proportional to the square of the potential difference of the quadrants. The physical explanation is that doubling the potential doubles the charges on the quadrants and the needle; and since the force is proportional to the product of these charges, the force is quadrupled.

For measuring large potential differences the quadrant

¹ J. J. Thomson's *Elements of Electricity and Magnetism*, p. 103.

electrometer, or electrostatic voltmeter, may be used idiosyncratically in a different way.¹ If the suspension is provided with a torsion head and a horizontal scale, graduated in equal divisions, the charged needle may be brought back to its initial or zero position by turning the torsion head and twisting the suspending fibre. This adjustment is made either by a telescope, or by means of a beam of light reflected from the mirror M . The forces are then proportional to the angular twist of the suspending fibre, and the potential difference to the square root of this twist. In this way potentials from 10 volts upwards may be readily measured.

PROBLEMS.

1. What would be the potential difference between A and B (Fig. 73) if O were charged with 100 units of $+$ electricity, the distance r being 10 cms. and r' 15 cms.?
2. Positive charges of 150, 424, and 300 units are placed at the three corners A, B, C , of a square 30 cms. on a side. Calculate the potential at the fourth corner D .
3. Positive charges of 50 units are placed at the three corners of an equilateral triangle whose sides are 50 cms. Find the potential at the centre of the circumscribing circle.
4. What would be the potential at the same point in the last problem if the charges were placed at the middle points of the three sides?
5. Find the potential at the centre of the square in problem 2, and the work to be done to bring a $+$ unit from D to the centre.
6. A sphere 10 cms. in diameter is charged with 50 units of positive electricity. Find the potential at the surface of the sphere, and at a point 20 cms. distant from its surface.

¹ Carhart and Patterson's *Electrical Measurements*, p. 200.

CHAPTER XIV.

CAPACITY AND CONDENSERS.

148. **Definition of Capacity.**—The electrical capacity of a conductor is defined as the numerical value of its charge when its potential is unity, all other conductors within its field being at zero potential. Since the potential of such a conductor is directly proportional to its charge, the charge corresponding to unit potential, or its capacity, may be found by dividing its total charge by the number of units of potential to which it is raised; or, in symbols,

$$C = \frac{Q}{V},$$

where C denotes the capacity. Also

$$Q = CV \text{ and } V = \frac{Q}{C}.$$

149. **Capacity of an Insulated Sphere.**—The capacity of a sphere at a great distance from all other conductors is numerically equal to its radius in centimetres. For the potential of such a sphere is Q/r .

Hence
$$C = \frac{Q}{V} = Q \div \frac{Q}{r} = r.$$

The radius must be expressed in centimetres because the centimetre is the unit of length employed in defining the unit of quantity.

Two spheres of unequal radii when charged to the same

potential have surface densities inversely as their radii. For

$$\sigma = \frac{Q}{4\pi r^2} = \frac{CV}{4\pi r^2} = \frac{V}{4\pi r}.$$

Therefore σ varies inversely as r , or, for the same potential,

$$\frac{\sigma_1}{\sigma_2} = \frac{r_2}{r_1}.$$

If a small sphere is connected to a large one by a fine wire, and if it is then supposed to diminish in size while its potential remains unchanged, the surface density on it will vary inversely as its radius. If it becomes indefinitely small, its surface density becomes indefinitely great. The electric intensity just at its surface increases therefore as its diameter decreases. This relation explains the discharging power of points.

150. Condensers.—Two conductors placed near together, but insulated from each other, form with the dielectric a *condenser*. The effect of the additional conductor is to increase the charge without any increase of potential. In other words, the capacity of the one conductor is greatly increased by the presence of the other. If the charges are equal and opposite in sign, the charge on either conductor when the potential difference between the two is unity is called the *capacity* of the *condenser*.

Let a horizontal brass plate with rounded edges be mounted on an insulating glass standard, and let a plate of glass CD (Fig. 78), larger than the brass plate, be placed on the latter. On this place another brass plate of the same dimensions as the lower one. Connect one plate with one electrode of an influence machine, and the other plate

with the other electrode, and charge them. If now they are disconnected from the machine and the upper one be touched with the finger, the attached pith-balls, which must be hung with linen threads, will collapse. But if the upper plate be lifted by its insulating stem, the pith-balls will again diverge and a small spark may be drawn from the plate. The two metal disks and the glass plate constitute a condenser.

If the upper plate be charged positively, its positive charge attracts a nearly equal negative charge on the lower plate, and the two are bound so long as the plates remain in position close together. The induction takes place through the glass, better in fact than through air.

Let the plates be again charged as before. If then one end of a bent wire be placed in contact with one plate and the other end be made to touch the other plate, a bright electric spark will pass just before the second contact is made. The charge of either plate is evidently greatly augmented by the presence of the other. If one plate be connected to the source of electrification and the other to the earth, then the former is called the *collecting* plate and the latter the *condensing* plate; the insulator between them is the *dielectric*, or the medium through which the mutual electric action between the plates takes place.

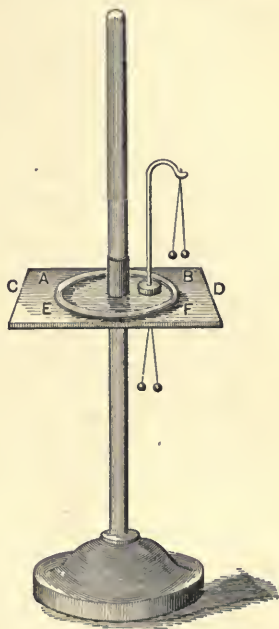

Fig. 78.

151. **Capacity of Two Concentric Spheres.** — Let the radius of the inner sphere be r and that of the inner surface of the outer one r' (Fig. 79), and let the outer sphere be connected to the earth. Then its potential and that of all other neighboring bodies is zero. Hence, since lines of force connect only bodies of different potentials, all the lines of force from the insulated charged sphere A run to the outer sphere B . Their charges are then equal and of opposite sign, $+Q$ and $-Q$.

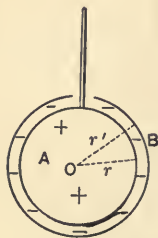

Fig. 79.

The potential at O , the common centre of the two spheres, is

$$V = \frac{Q}{r} - \frac{Q}{r'} = Q \left(\frac{1}{r} - \frac{1}{r'} \right).$$

But this is the potential of the inner sphere because the potential inside a charged conductor is the same as at any point on its surface. From the last equation

$$Q = V \frac{rr'}{r' - r}.$$

When V becomes unity the charge by definition is the capacity, or

$$C = \frac{rr'}{r' - r}.$$

When $r' - r$ is very small, that is, when the two spherical surfaces are very near together, the capacity becomes very large. The expression for the capacity is then

$$\frac{rr'}{t} = \frac{r(r+t)}{t},$$

where t is the thickness of the dielectric. When t is very small compared with r , this expression becomes

$$\frac{r^2}{t} = \frac{4\pi r^2}{4\pi t} = \frac{S}{4\pi t},$$

where S is the surface of the sphere. The capacity per unit area in air is therefore $1/4\pi$ times the reciprocal of the distance between the conductors.

If the outer sphere be supposed to expand indefinitely, or to be removed, while the inner one is insulated, the potential of the inner sphere will increase; for

$$V = Q \frac{r' - r}{rr'}$$

Now if r and r' are very nearly the same, the potential for a given charge Q may be small; but as r' increases, $(r' - r)/r'$ approaches unity and finally $V = Q/r$. The condensing plate decreases the potential, therefore, in the ratio of $r' - r$ to r' , the charge on the collecting plate remaining the same. Or conversely, for the same potential, the condensing plate increases the charge in the ratio of r' to $r' - r$.

152. Capacity of Two Parallel Plates. — When the plates are so close together that the curved lines at the edges are negligible in comparison with the others, all the lines may be conceived as straight and at right angles to the plates. The capacity is then easily calculated. If t is the distance separating the plates, or the thickness of the air film as the dielectric, then the electric intensity between the plates is uniform, and the work done in conveying a unit charge from the plate of higher potential to the other is

$$V = Ft,$$

where V is the potential difference between the plates and F is the electric intensity.

The surface densities will be equal and of opposite sign, $+\sigma$ on the one of higher potential and $-\sigma$ on the other. Then the electric intensity between the plates is $4\pi\sigma$, half

of this expression being due to the charge on one plate and the other half to the other, as before explained. Therefore

$$F = 4\pi\sigma,$$

and from the last equation $V = 4\pi\sigma t$.

If A is the area of each plate,

$$Q = A\sigma = V \frac{A}{4\pi t}.$$

When V is unity the charge on one of the plates of area A is $A/4\pi t$, and this by definition is the capacity. This expression is the same as that for the capacity of two concentric spheres.

153. The Leyden Jar. — The Leyden jar was the earliest form of condenser. It was discovered accidentally by Cuneus at Leyden in 1746 while attempting to collect “electric fluid” in a bottle half filled with water and held in the hand. The water was connected with an electric machine. While holding the bottle in one hand and attempting to remove the connecting chain with the other Cuneus received an unexpected shock, from which it took two days to recover his mental equilibrium. It is evident that the water in the bottle served as the collecting plate and the hand as the condensing plate, the glass being the dielectric.

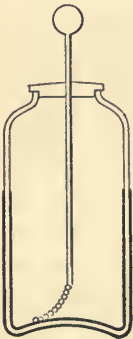

Fig. 80.

As now made a Leyden jar consists of a wide-mouthed jar of thin flint glass, coated within and without with tin foil for about three-fourths of its height (Fig. 80). The metal knob is connected to the inner coating by a rod terminating in a short piece of chain. The jar may be charged by holding it in the hand, touching the knob to

one electrode of an influence machine, and bringing the outer coating so near the other electrode that a series of sparks will pass across. If charged too highly it will discharge along the glass over the top. A hissing, crackling sound indicates a partial brush discharge over the surface of the glass above the tin foil. It may be safely discharged by a discharger (Fig. 81) held by the glass handles, one ball being brought into contact with the outer coating and the other with the knob.



Fig. 81.

If A is the area of the tin foil and t the thickness of the glass, then if the space between the tin-foil coatings were filled with air, the capacity would be approximately

$$\frac{A}{4\pi t},$$

since this case is practically the same as that of two parallel plates, if t is small in comparison with the radius of the jar. It will be explained shortly that the effect of interposing the glass instead of air between the two coatings is to increase the capacity by a factor K , so that

$$C = K \frac{A}{4\pi t}.$$

K is a constant depending on the kind of glass, and varies from about 4 to 10 for different specimens.

154. **Residual Charge.** — If a Leyden jar be left standing for a few minutes after it has been discharged, the two coatings will gradually acquire a small potential difference and a small discharge can be again obtained from it. This is called the *residual charge*. Several of them, of

decreasing potentials, may sometimes be observed. The magnitude of the residual charge depends upon the original potential difference to which the jar was charged, the length of time it is left charged, and the kind of glass of which it is made.

155. **Seat of the Charge.**—The Leyden jar with removable coatings is due to Franklin. By means of it he showed that the charge resides on the surface of the glass.

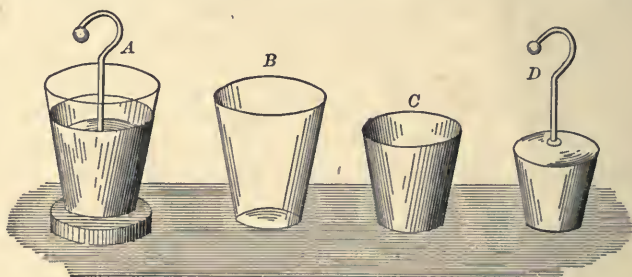

Fig. 82.

A (Fig. 82) is the jar complete, *B* is the glass vessel, *C* the outer and *D* the inner metallic plate. If the jar be charged in the usual way and be placed on an insulating support, the inner plate may be removed by lifting it by the curved rod; then the outer plate may be removed from the glass jar. The two plates are then completely discharged. After putting the jar together again, it can be discharged with a bright flash. The coatings serve as dischargers for the glass. The charge on two small areas of the glass may be made to unite with a crackling sound by touching them at the same time with the fingers. "The two conducting surfaces may therefore be regarded simply as the boundaries of the intervening dielectric."

156. **Energy expended in charging a Condenser.**—The energy expended (138) in transferring Q units of electricity through a potential difference of $V - V_0$ is $Q(V - V_0)$. If the charge Q is transferred from the earth, whose potential is zero, to a conductor whose potential is V , the work done is QV . But in charging a condenser, or any conductor, the potential is zero at the beginning of the charging and V at the end. The mean potential to which the charge is raised is then $\frac{1}{2}V$. The work done in charging the condenser is therefore

$$W = \frac{1}{2}QV.$$

But since $Q = CV$,

$$W = \frac{1}{2}CV^2 = \frac{1}{2}Q^2 / C.$$

The energy expended in charging a condenser to a potential difference V is one-half the product of the capacity and the square of the potential difference. Potential corresponds to height when work is done against gravity. Thus in building a brick tower of uniform cross-section A , the mean height to which the bricks are lifted is half the final height of the tower; the work done in gravitational units is one-half the product of the mass M and the height h of the tower. If with half the cross-section the tower is carried to twice the height, the work done is simply doubled because the same mass is lifted to double the mean height. If, however, the tower with the cross-section A is built to twice the height $2h$, the work is quadrupled, because both the mass lifted and the mean height are doubled. The constant is the area A , corresponding to capacity, and the work done varies as the square of the height.

157. **Energy lost in dividing a Charge.**—Let C_1 and C_2 be the capacities of two condensers, and let the first be

charged with a quantity Q . The energy of the charge is

$$\frac{1}{2} C_1 V^2 = \frac{1}{2} \frac{Q^2}{C_1}.$$

After the charge has been divided between the two condensers by connecting them in parallel, the potential difference has fallen to $\frac{Q}{C_1 + C_2}$. Hence the energy is then

$$\frac{1}{2} (C_1 + C_2) \left(\frac{Q}{C_1 + C_2} \right)^2 = \frac{1}{2} \frac{Q^2}{C_1 + C_2}.$$

It is less than the energy before the division so long as C_2 has any value in comparison with C_1 . If the two capacities are equal, the energy after the division is one-half as great as before it. The other half is represented by the energy of the spark at the moment of the division. The lowering of the potential by the increase of capacity diminishes the energy represented by a given charge. Energy is always lost by the division, whatever be the relative capacities of the condensers, except when the potential differences of the two are the same before they are joined in parallel; but in this case there is no electric flow and no lowering of the potential difference.

153. **Energy of Similar Condensers in Parallel.** — If

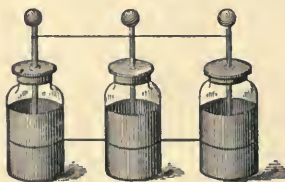

Fig. 83.

n condensers of the same capacity C are charged in parallel, for example, n Leyden jars of the same size with their outside coatings connected together, and likewise all their inside coatings (Fig. 83), the capacity of the whole is n

times the capacity of a single condenser, because the effect is simply to increase the size of the coatings.

The energy of discharge of a single condenser is $\frac{1}{2}CV^2$, and for n condensers of the same capacity it is

$$n \times \frac{1}{2}CV^2 = \frac{1}{2}nCV^2.$$

The energy is thus increased in proportion to the number of similar condensers.

159. Energy of Condensers connected in Series. —

If several Leyden jars are insulated and the outside of the first is connected to the inside of the second, etc. (Fig. 84), they are said to be connected in series or in "cascade." The inside of the first jar is one side of the compound condenser, and the outside of the last one is the other side. If the potential difference between the two sides is V , then the energy of each of the n similar jars is $\frac{1}{2}C\frac{V^2}{n^2}$; and the energy of the charge in the n jars is

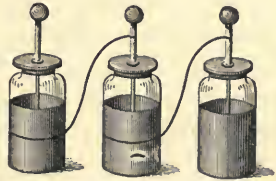

Fig. 84.

$$W = \frac{1}{2n} CV^2.$$

Hence the energy of the charge of the n jars in series is $1/n$ of the energy of one of the jars charged to the same potential difference between its two coatings.

160. Electric Strain. — The phenomenon of the residual charge may be best explained by considering the dielectric as the medium through whose agency the induction takes place. The charging of a Leyden jar is accompanied by the straining of the glass. If the potential difference is raised to a sufficiently high value, the glass may be strained beyond the elastic limit and may give way with a disruptive

discharge of the jar. The glass is then shattered at the point through which the discharge takes place. In the case of air or other fluid dielectrics, such as insulating oils, the dielectric may be broken down by a disruptive discharge, but the damage is immediately repaired by the inflow of the insulating fluid.

By subjecting plate glass to powerful electrostatic stress and passing plane polarized light through it at right angles to the lines of force, Kerr discovered that glass becomes doubly refracting, and is strained as if it were compressed along lines of force. Quartz behaves in the same way, but resins and all insulating fluids examined, except olive oil, act as if extended along lines of force. The action requires about thirty seconds to reach its maximum effect, and about the same time is required for complete recovery. Kohlrausch and others have pointed out the analogy between Kerr's discovery and the elastic fatigue of solids after being subjected to a twisting strain. A fibre of glass if twisted does not immediately regain its initial form when released from the stress, but a slight set remains from which it slowly recovers.

The glass of a charged jar is then greatly strained, and it does not at once recover when the jar is discharged. Its after-recovery from distortion sets free energy which is represented by the residual charge. Hopkinson has shown that it is possible to superpose several residual charges of opposite signs. In the same way a glass fibre may be twisted first in one direction and then the other, and the residual twists will appear in reverse order. No residual charges can be obtained from air condensers, nor from those with quartz plates. Correspondingly, quartz shows no elastic fatigue after being twisted.

Siemens has shown that the glass of a Leyden jar is

sensibly warmed by rapid charging and discharging. The distortion shows a lag behind the electric stress, a phenomenon known as *hysteresis* when applied to magnetic induction. The result in both cases is the absorption of energy and the generation of heat. The quantity of heat generated is proportional to the square of the potential difference to which the condenser is subjected.

161. Dielectric Polarization (B., 573). — Faraday's theory of induction was that it is an action between contiguous parts of the dielectric, resulting in a certain polarized state of its particles. In proof of this polarization he placed bits of dry silk filaments in turpentine contained in a long rectangular glass vessel with pointed conductors entering from opposite ends. When one of these was connected with

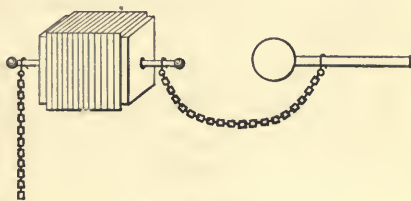

Fig. 85.

the earth and the other with a frictional machine, the bits of silk collected together along lines of induction, forming long filaments of considerable tenacity. Matteucci demonstrated that the dielectric is polarized or charged by contiguous particles throughout. He formed a condenser of a large number of thin plates of mica compressed between two terminal metal plates (Fig. 85). After charging it and insulating, it was found on removing the mica plates and examining them that each one was charged positively on one side and negatively on the other, all the positive sides being turned toward the positive electrode, and all the negative ones in the opposite direction.

Maxwell explains the residual charge by assuming that

the dielectric is not homogeneous, and that it therefore becomes electrified at the surfaces separating the non-homogeneous parts, like the electrification of the mica plates. The reunion of these charges is gradual after the first discharge, and their external effect is shown as a residual charge. "According to this theory all charge is the residual effect of the polarization of the dielectric" (Maxwell). In the interior of the dielectric the polarization is neutralized by adjacent opposite charges; "it is only at the surface of the dielectric that the effects of the charge become apparent."

162. Distinction between Conductors and Insulators (Max., 156). — The potential difference between the boundaries of a dielectric is the electromotive force acting on it. If the dielectric is an imperfect insulator, the state of constraint is continually giving way or being relaxed. The medium yields to the electromotive force, and the potential energy of its distortion is converted into heat. In good insulators the rate at which this conversion takes place is very slow.

In conductors the electric polarization gives way as fast as it is produced by the electromotive force, with a steady transfer of electricity; this transfer is called an electric current. The external agency which maintains the current is constantly doing work in restoring the polarization, and the result of expending energy on the conductor is the generation of heat. Non-conductors are capable of maintaining the state of electric polarization; in conductors this polarization breaks down as fast as it is formed. The application of an electromotive force to the former causes a momentary transfer of electricity; its application to the latter produces an electric current.

163. Electric Displacement.—Electricity exhibits the properties of an incompressible fluid. Electric charges reveal themselves only at the boundaries between conductors and the dielectric. Lines of induction run from the positive charge at one boundary through the dielectric to the negative at the other; and if we conceive tubes of induction bounded laterally by lines of induction, every tube in a dielectric between two conductors has equal charges on its two ends, or the induced and the inducing charges are equal to each other. All cases of electrification are cases of the transfer of electricity. Hence Maxwell proposed his theory of *electric displacement*, which supposes that when an electromotive force acts on a dielectric, as in induction, electricity is transferred or displaced along tubes of induction. The electromotive force not only distorts the medium, but transfers electricity by stretching the dielectric. If a dielectric, polarized by electric displacement, be left to itself, the elastic reaction produces a back electromotive force and a reverse electric transfer to restore the equilibrium. This restoration to equilibrium constitutes the discharge of the condenser. A disruptive discharge means the rupture of the dielectric, usually the air. If the discharge is abrupt, the sudden release of the dielectric from strain is followed by rapid electric displacements in opposite directions alternately, till the energy of the charge is all wasted in heat. This phenomenon is known as the oscillatory discharge of a condenser. It was discovered by Joseph Henry in 1842.

164. Electric Transfer always in Closed Circuits.—The electric-displacement theory of Maxwell has led to a conception of the electric circuit which allows the contrast between a conducting and a non-conducting circuit to be

expressed in a simple manner. In a circuit made up entirely of conductors the operation of an electromotive force causes a continuous flow of electricity; but if the circuit is only partly conducting and in part composed of a dielectric, then the action of an electromotive force in the circuit produces a transient electric flow through the conductor and an equivalent displacement through the dielectric. The amount of the flow depends on the capacity of the dielectric as a condenser and the magnitude of the electromotive force, or $Q = CV$. Through the conductor electricity is transferred by the process of conduction; through the dielectric it is transferred as a displacement,

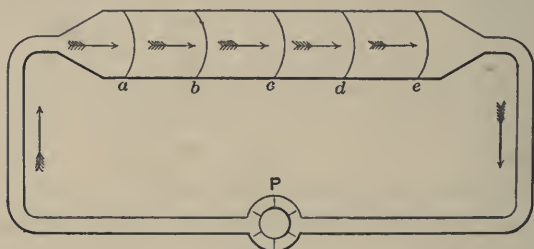

Fig. 86.

that is, it is forced along by straining the medium. Displacement always produces a reactive electromotive force which counterbalances the direct electromotive force and effects a discharge when the latter is removed.

Consider a circuit of water-pipes filled with water and containing a pump P (Fig. 86). If there were no obstructions in the pipes the motion of the pump would cause a circulation of water through the system. This arrangement corresponds to a conducting circuit. But if we imagine elastic diaphragms stretched across the enlarged pipe at many points, as a, b, c, d, e , the rotation of

the pump, so as to produce a flow in the direction of the arrows, displaces water along the enlarged pipe by stretching the diaphragms, and causes a transient current through the remainder of the system. The displacement ceases as soon as the reaction of the diaphragms equals the force applied to the pump. The same quantity of water is transferred across every cross-section of the pipes throughout the whole system, whether the diaphragms are present or not. Without the diaphragms the flow would be continuous; with them it continues only so long as they yield to the stress of the water. If the force applied to the pump be withdrawn, the reaction of the tense diaphragms produces a counter-flow. The diaphragms represent the dielectric and the unobstructed pipes the conductor. So in charging a condenser the same quantity of electricity is displaced through the dielectric as flows along the conducting part of the circuit.

165. Specific Inductive Capacity.—Different dielectrics possess different powers of transmitting induction across them. The density of the charges at the surfaces of the condensing plates; with a given difference of potential between them, depends not only on the distance between them, but also on the facility with which the dielectric permits electric displacement.

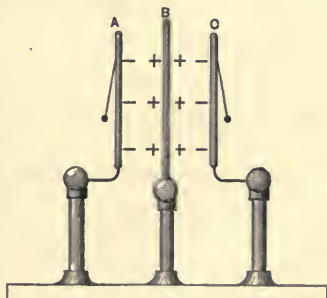

Fig. 87.

Let A , B , C (Fig. 87), be three insulated conducting plates. To the back of A and C are suspended pith-balls. Let B receive a positive charge and let A and C be charged

negatively by induction. If they are touched with the finger the pith-balls will collapse and remain in contact with the plates. If now A , for example, be moved nearer to B , both pith-balls will diverge, the one on A with a + charge and the one on C with a - one. The diminished distance between A and B permits increased induction which transfers + electricity to the back of A ; but the increased induction on the left of B diminishes it on the right, and some of the - charge on C becomes free and spreads over the back of the plate.

Replace A in the first position, with B charged as before and the pith-balls not diverging. Interpose between A and B , without touching them, a thick plate of glass or sulphur. Both pith-balls will again diverge as if A had been moved nearer B , showing that the effect is the same as the reduction of the thickness of the air between the plates. The capacity of a condenser depends then on the nature of the insulating medium between the two opposed conductors. The *specific inductive capacity*, or *dielectric constant*, of a substance is the ratio of the capacity of a condenser with the substance as the dielectric to its capacity when the dielectric is air. The dielectric constants of all gases are nearly the same, but those of solids differ greatly.

166. Faraday's Experiments.—The first experiments on specific inductive capacity were those of Cavendish, but they were unknown till Faraday had made his discoveries in the same subject. Faraday's experiments were made with two exactly similar condensers shown in section in Fig. 88. The metallic sphere A is supported by the rod M , and both are insulated from the outer shell B by a plug of shellac. The shell B is made in two halves which can be detached from each other, so that the space between

A and *B* can be filled either with a solid dielectric or with a gas.

When both condensers were filled with dry air and one of them was charged, it divided its charge equally with the other on joining them in parallel, its potential falling to one-half. The capacities of the two were therefore the same. The space within one of the condensers was then filled with a solid, such as shellac, and the above experiment was repeated. The resulting potential was then less than half the initial potential.

Let V be the potential of the air condenser before the division of the charge, and C its capacity. If K is the specific inductive capacity of the dielectric in the second condenser, the capacity of this condenser will be KC . Let V' be the common potential of the two after the division of the charge; then

$$Q = VC = V'(C + KC).$$

Whence
$$K = \frac{V - V'}{V'}.$$

In this way Faraday obtained for sulphur, as compared with air, the value 2.26, and for shellac, 2.0.

Faraday's discovery of this property of a dielectric led him to adopt the view that the effects observed in an electric field are to be ascribed to the action of the dielectric between electrified bodies, and not to the action of an electrified body on others at a distance.

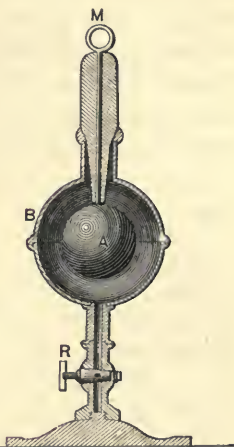

Fig. 88.

167. **Recent Results.** — The dielectric constant is smaller in rapidly oscillating fields than in slowly changing ones, because of the absorption of the charge which takes place with the continued application of an electromotive force in one direction. This fact explains to a certain extent the great discrepancies which are found among the results obtained by different observers. The following table illustrates the difference between the values derived from rapid and from slow methods :

	Rapid.	Slow.
Glass	3.013 to 3.243	
“ dense flint		7.37
“ light flint		6.72
Ebonite	2.284	3.15
Gutta-percha	2.462	
Paraffin (solid)	1.994	2.29
“ (liquid)		1.92
Shellac	2.747	
Sulphur	2.579	3.97
Mica		6.64
Turpentine		2.23
Distilled water		76.
Alcohol		26.

Northrup has recently measured the specific inductive capacity of paraffin and plate glass, both with rapidly oscillating and slowly changing fields, with the following results :

	Rapid.	Slow.
Paraffin	2.25	2.32
Plate glass	5.86	6.25

The following are the specific inductive capacities of several gases :

Hydrogen	0.999674	Carbon monoxide	1.001
Carbon dioxide	1.000356	Olefiant gas	1.000722
Sulphur dioxide	1.0037		

168. **Effect of the Dielectric on the Electric Intensity** (J. J. T., 116). — Consider two parallel-plate condensers A and B , the plates being at the same distance in the two, but the dielectric of A being air and that of B a medium whose specific inductive capacity is K . Let us suppose the charge per unit area, or the surface density, on the plates of A and B is the same. Then, since the potentials are inversely as the capacities when the charges are the same, and since the capacity of B is K times that of A , it follows that the potential difference between the plates of A is K times as great as that between the plates of B . But in both cases the electric intensity in the dielectric is the rate of variation of the potential per unit length. Now as the thickness of the dielectric is the same in A as in B , while the potential difference of A is K times as great as in B , it follows that the electric intensity in the air between the plates of A is K times as great as in the dielectric of B , or the electric intensity is inversely as the specific inductive capacity.

We have seen in Art. 152 that the electric intensity F between two plates in air is $4\pi\sigma$. Hence in a medium whose dielectric constant is K ,

$$F = \frac{4\pi\sigma}{K}.$$

Thus with given charges the forces in the field are diminished by introducing a medium with a large specific inductive capacity.

169. **Effect of the Dielectric on the Forces between the Plates.** — From the equation of the last article,

$$4\pi\sigma = KF = \frac{KV}{t},$$

where t is the thickness of the dielectric.

Whence
$$\sigma = \frac{KV}{4\pi t}.$$

The force on unit quantity on one of the plates, due to the charge on the other, is $\frac{1}{2}F$, and on unit area it is $\frac{1}{2}F\sigma$. Hence the force on either plate per unit area is

$$\frac{F\sigma}{2} = \frac{2\pi\sigma^2}{K}.$$

With a given charge, or given surface density, the force between the plates is inversely as the specific inductive capacity.

Again, since
$$\frac{F\sigma}{2} = \frac{V}{2t} \cdot \frac{KV}{4\pi t} = \frac{KV^2}{8\pi t^2},$$

it follows that, with a given potential difference, the force between the plates is directly proportional to the specific inductive capacity.

PROBLEMS.

1. Two Leyden jars are charged with quantities as 1 to 4. The tin-foil surface of the second jar is twice as large as that of the first and the glass is half as thick. Find the relative energy of the two charges.

2. An insulated metal ball of 10 cms. radius, and removed from all other conductors, is charged with 100 units of electricity. What will be its potential if it be then surrounded by a smooth conducting shell of 11 cms. radius, and connected to earth?

3. If one of two insulated conducting spheres, 20 cms. in diameter, be charged to a potential of 15 units, and then be connected with the other sphere, by means of a long thin wire, find the energy of the discharge between them.

4. Two Leyden jars of 200 sq. cms. tin-foil surface and glass 1 mm. thick, specific inductive capacity 6.283, are charged to potentials of 100 and 10 units respectively. Find the energy lost in ergs on connecting them in parallel.

5. Find the capacity of a spherical condenser, the radii of the

opposed surfaces being 9 and 10 cms., and the dielectric paraffin, whose specific inductive capacity is 2.3.

6. Two circular brass plates 30 cms. in diameter are separated by glass 2 mms. thick and of specific inductive capacity 6. If they are charged to a potential difference of 1,000 units, find the force of attraction between them.

7. In the last problem, find the surface density on the boundary between the glass and the plates.

CHAPTER XV.

ATMOSPHERIC ELECTRICITY.

170. **Lightning an Electrical Phenomenon.** — While some of the early philosophers surmised that the lightning flash was an electrical discharge, yet this view obtained but little currency till Franklin's suggestion in 1749 to apply his discovery of the discharging power of points to the investigation of the problem had actually been carried into effect. In 1752 d'Alibard, acting on Franklin's suggestion, erected an iron rod 40 feet high, but not connected with the earth, and drew sparks from passing clouds. About the same time (1752) Franklin sent up his famous kite by means of a linen thread, during a passing storm, and held it by means of a silk ribbon between his hand and a key attached to the thread. When the thread had been wetted by the rain, sparks were drawn from the key and a Leyden jar was charged. The next year Richmann, of St. Petersburg, was killed by lightning while experimenting with a rod similar to that of d'Alibard.

171. **The High Potential of Thunder Clouds.** — The source of the electrification of the atmosphere and of clouds remains as yet unsettled. But given ever so slight an electrification of aqueous vapor, it is not difficult to account for the high potential exhibited by thunder clouds.¹

¹ *Atmospheric Electricity*, Carhart, *Jour. Am. Elec. Soc.*, 1880.

Consider minute spherules of water condensing to large drops in the formation of clouds and rain. Since the volumes of spheres vary as the cubes of their radii, eight small drops condense into one of double radius. Therefore each of the larger drops contains eight times the charge of the smaller ones. But since the capacity of a sphere is numerically equal to its radius, the larger sphere has only double the capacity of the smaller ones. Therefore its potential, which is the quotient of the charge by the capacity, is quadrupled. The potential then increases as the square of the radius of the drops. If the potential rises according to such a law, the inductive influence and tendency to discharge from drop to drop through a cloudy atmosphere rise in the same proportion.

172. **Effect of Electrification on Condensation.** — It is a fact of common observation that a small ascending jet of water is resolved into drops, which describe divergent trajectories. By reason of the different velocities and directions of motion of the individual drops they come into frequent collision and then rebound. The influence of electrification on the recoil of the drops after collision is most marked and interesting. The subject has been investigated by Lord Rayleigh¹ with important results.

If the ascending jet is strongly electrified, the repulsion between the drops scatters them and prevents collision; but with very feeble electrification, the drops coalesce on impact and the stream is thus rendered much smoother. This coalescence was demonstrated to be due to slightly different degrees of electrification in the impinging particles of water. Their attraction and union appear to be due to induction, the resulting force of which is always an attraction.

¹ *Proceedings of the Royal Soc.*, Vol. LXXVIII., p. 406.

The bearing of these results on precipitation of aqueous vapor is obvious. Innumerable minute globules of water, feebly charged to different potentials, collide and coalesce into drops which descend by gravity. A slight amount of electricity in the atmosphere is therefore favorable to aqueous precipitation, while higher electrical excitation is unfavorable to it.

It is an observed fact of frequent occurrence that a vivid flash of lightning is quickly followed by a sudden and heavy downpour of rain. It is clearly impossible to tell which is antecedent to the other, the discharge or the condensation; for, while the flash reaches the observer first, light travels from the place of condensation in negligible time, and the discharge may therefore be subsequent to the sudden condensation. If the condensation occurs before the discharge, it is accompanied by a sudden rise of potential in the enlarged drops, leading to an electric discharge.

173. Lightning Flashes. — Lightning flashes are discharges between oppositely charged conductors. They may occur between two clouds or between a cloud and the earth. The rise of potential in a cloud causes a corresponding accumulation in the earth underneath; and unless this accumulated charge is carried off by the silent action of points, when the stress in the air as the dielectric reaches a certain limiting value, the air breaks down with a sudden subsidence to equilibrium. J. J. Thomson estimates the dielectric strength of the air under ordinary conditions of pressure and temperature to be about 0.41 gm., or 398 dynes, per square centimetre. When the electric tension along lines of force is greater than this, a disruptive discharge takes place. This limiting stress may be reached in two different ways, which will now be described.

174. **Discharge with Steady Strain.** — When the stress in the dielectric is gradually increased, the medium is finally strained to the point of rupture, and a discharge takes place. Under these circumstances a point will offer protection and effect a silent discharge. This condition Lodge has called the “steady strain,” and has illustrated it as follows:¹ *A* and *B* (Fig. 89) are the discharge terminals of an influence machine, *L* is a Leyden jar, *T* and *T'* two tin plates connected with the two coatings of the jar.

On the lower plate are three conductors terminating as shown. Under these conditions, as the jar is charged the stress increases gradually; but the pointed conductor, even when very low compared with the others, prevents a discharge altogether. This is true even when a high liquid resistance is interposed between it and the lower tray. If the point be removed or covered, and the knobs be positive, long flashes may be obtained, but always to the small knob until it is about three times as far from the upper plate as the large knob. The reason for these phenomena is that the air breaks down at the weakest point, or where the stress is greatest, and this is at the surface of greatest curvature or smallest area. The high liquid resistance interposed in the path of the discharger makes no difference in the length of the spark, but does affect its noise and violence.

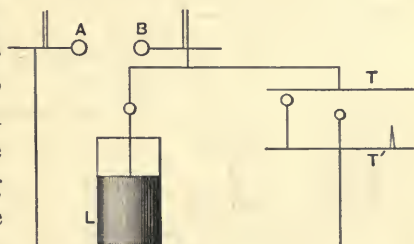

Fig. 89.

increases gradually; but the pointed conductor, even when very low compared with the others, prevents a discharge altogether. This is true even when a high liquid resistance is interposed between it and the lower tray. If the point be removed or covered, and the knobs be positive, long flashes may be obtained, but always to the small knob until it is about three times as far from the upper plate as the large knob. The reason for these phenomena is that the air breaks down at the weakest point, or where the stress is greatest, and this is at the surface of greatest curvature or smallest area. The high liquid resistance interposed in the path of the discharger makes no difference in the length of the spark, but does affect its noise and violence.

¹ Lodge's *Lightning Conductors and Lightning Guards*, p. 54.

175. **Discharge with Impulsive Rush.** — In the last article the potential difference between the plates increases gradually till the limit of the dielectric strength of the air is reached. Lodge has arranged a different experiment to illustrate the very sudden development of a potential difference and a discharge with an “impulsive rush.”

The two Leyden jars in series (Fig. 90) stand on the same wooden table.

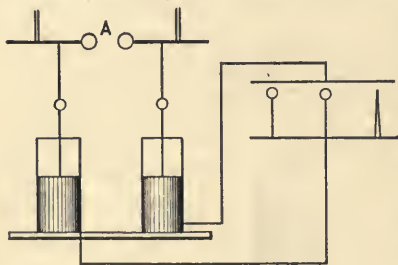

Fig. 90.

They charge gradually, the outer surfaces through the table, and ultimately discharge at *A*. This discharge between the inner coats releases the charges on the outer coats, a violent rush takes place, produc-

ing a sudden stress in the medium between the plates, and the conductors are struck. The small knob no longer protects the larger one, nor does the point exert any special protective influence. All three terminals are equally liable to be struck, if of the same height, and all three may be struck at once. If a liquid resistance is interposed in the path of either, it fails to protect the other two even if taller than they. In this case the electric pressure is developed with such impulsive suddenness that the dielectric appears to be as liable to break down at one point as another. Such sudden rushes are liable to occur when two clouds spark into each other, and then one overflows into the earth. The highest and best conducting objects are then struck irrespective of points and terminals. The conditions determining the path of the discharge in the case of these impulsive rushes are entirely different from

those of the steady strain, and points are incompetent to afford protection by preventing them.

176. Lightning Protectors.—The revision of theory and the results of experiment have left much of former recommendations relating to lightning protectors of doubtful value. Some of the reasons for this statement will appear in treating current induction in a later chapter; enough has already been said to furnish a basis for a few simple directions concerning protection from lightning.

For the condition of steady strain pointed conductors are still advisable; but it is not necessary to provide the elaborate terminals formerly deemed essential. Nor is a copper conductor of large section necessary or desirable. It is far better to provide a number of paths for the discharge down several different parts of a building, each consisting of a large galvanized-iron wire sharpened at the top, avoiding short bends and loops, and ending in a mass of iron or charcoal buried in moist earth. Such a conductor may be fastened directly to the building without insulators. It is probable that a number 4 or 6 iron wire, B.S.G., will safely carry off any discharge that is likely to traverse it. The writer has known a much smaller iron wire to conduct safely a discharge which converted smaller copper wire into metallic vapor and did other damage. It is not desirable that the lightning conductor should have a very low resistance. If it is large enough to convey the current without fusion, it will dispose of the energy of the discharge at a safer rate than a larger conductor would.

Tall chimneys may be adequately protected by three or four iron wires ranged around the outside, not placed together, but connected at frequent intervals, and all well.

grounded. Since the heated air of a chimney furnishes an easy path for lightning, it is well to connect the iron wires with a copper band just above the mouth of the chimney.

The expense of erecting such lightning guards is merely nominal. When coal is burned they will need renewal occasionally on chimneys; the expense of such renewals is inconsiderable, but the need of repairs is often overlooked till the damage is done.

177. Method of measuring the Potential of the Air.

— The earth is almost always negative relative to the air, and the potential of the latter increases with the elevation above the surface. The quadrant electrometer has done excellent service in these determinations. To put the needle or one pair of quadrants in electrical equilibrium with the air at any elevation, the slow match and the water-dropping collector are the most effective. Both of these, when insulated from the earth, furnish means of electrical convection by the disengagement and release of small particles. Each small mass carries with it an electrical charge, and the potential of the conductor is thereby quickly brought to that of the equipotential surface of the air passing through the point from which the matter breaks away. The water-dropper is a well-insulated reservoir from which a long tube extends through an opening in the wall, so that the nozzle is in the open air. In half a minute after turning the tap, the potential of the system is reduced to that of the air at the point where the jet of water ceases to be a continuous stream.

Mascart's method of using the quadrant electrometer for this particular purpose is preferable to the older procedure. The middle point of a large number of cells of battery, or simple elements of zinc and copper in distilled water

(183), is put to earth, while one of its terminals is connected to one pair of quadrants and the other terminal to the alternate pair. The water-dropping collector is connected to the needle. The alternate quadrants are then charged to equal potentials of opposite sign, and the amount and direction of the deflection depends on the value and sign of the charge conveyed to the needle.

178. Results of Observation. — Disruptive discharges occur when the stress in the air exceeds the limit of its dielectric strength (173). The needle of the electrometer becomes very much agitated on the approach of a thunder cloud; and after various fluctuations it settles down to a steadily increasing deflection in one direction until a flash of lightning occurs, when the needle darts back to zero. The lightning flash indicates a return of the strained medium to equilibrium.

In clear weather the potential of the air is sometimes nearly as high as during a storm, but shows smaller fluctuations. The value of the potential gradient found by McAdie at the Blue Hill Observatory,¹ as the result of over a thousand observations, was 540 volts (189) for a difference of elevation of 138 metres. This is equivalent to 3.91 volts per metre, or 0.00013 electrostatic units per centimetre of elevation. On certain clear days the variation of potential with the elevation reached twice this value, or about 8 volts per metre. During thunder storms the potential gradient may amount to 35 volts per metre, or 0.0012 electrostatic units per centimetre.

By means of kites McAdie has shown that the potential difference in clear weather increases as the kite rises; and, further, that it is possible to obtain sparks from a perfectly

¹*Annals of the Astron. Observ. of Harvard College*, Vol. XL., Part I.

cloudless sky, and generally at an elevation not exceeding 500 metres.

From a long series of observations at Washington, Professor Mendenhall concludes that the electrical condition of the atmosphere furnishes no reliable data for weather forecasts.

179. **The Aurora.** — The *aurora*, or polar light, is due to silent or brush discharges in the upper regions of the atmosphere. In the arctic regions it occurs almost nightly, but with varying intensity. Lemström has shown that the illumination of the aurora is due to currents of positive electricity passing from the higher regions of the atmosphere to the earth. In our latitude these silent discharges in the rarefied atmosphere are infrequent. When they are visible they are accompanied by great disturbances of the earth's magnetism and by earth currents. In polar latitudes the irregular motions of the magnetic needle indicate the coming of auroral displays. These magnetic disturbances are sometimes of simultaneous occurrence in widely separated portions of the earth.

CHAPTER XVI.

PRIMARY CELLS.

180. **Steady Currents.** — It has been shown that a Holtz influence machine, when rotated uniformly, is capable of producing an electric current; that is, a uniform as distinguished from a transient flux of electricity through a conducting circuit. But the resistance which the machine itself opposes to any transfer of electricity reduces the current to a very small value.

To produce a uniform electric current through a conductor, a constant potential difference must be maintained between its terminals. The quantity which flows in unit time along the conductor is called the *strength* or *intensity* of the current. It is impracticable to effect this uniform flow by an influence machine, and much more so by a frictional machine. It may be done by the application of chemical energy, as in the voltaic cell; by the application of heat, as in the thermal couple; or by the application of mechanical energy, as in the dynamo machine. In all three cases the energy applied is converted, at least in part, into the energy of the transport of electricity under an electric pressure equal to the potential difference established by the apparatus. These three methods of maintaining a difference of electric potential will be taken up in order.

181. **Volta's Pile.** — The modern electrical era dates from Galvani's discovery, in 1786, that muscular contrac-

tions are produced when a bimetallic arc of iron and copper connects the lumbar nerve and the crural muscle of a freshly killed frog. In the hands of Volta this observation ripened into the discovery that a potential difference is established by the contact of two different metals, such as zinc and copper, especially if they are separated, except at the point of contact, by moist cloth. Volta constructed a chain of elements to which in 1800 he gave the name *artificial electric organ*, but which has since been known as the voltaic pile.

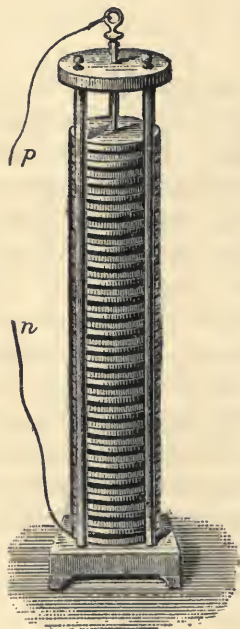

Fig. 91.

It consisted of many disks of copper and zinc, either placed in contact or soldered together in pairs, and piled up with interposed layers of cloth moistened with water, or with a solution of salt. The order of assemblage was zinc-copper-cloth, zinc-copper-cloth, from bottom to top. Fig. 91 shows one of the early forms, with zinc at the bottom and copper at the top. The column was held in place by glass rods. The bottom disk was called the negative pole and the top one the positive. A pile composed of from twenty to forty pairs produced sensible physiological effects when the experimenter grasped the two terminal wires *n* and *p* with moistened hands, or placed them on the tongue.

182. **The Dry Pile.** — Behrens and Zamboni replaced the cloth in Volta's pile with paper, and made what was

called a *dry pile*. It was made of gold and silver paper, the former coated on one side with copper foil and the latter with tin foil. Sheets of these papers were placed together with their metallic sides outward, and small disks cut from them were piled up to the number of many hundreds or even thousands, in such a way that the copper of all the pairs was turned in the same direction. Such dry piles were capable of charging Leyden jars and of producing shocks.

In the Clarendon laboratory at Oxford is an instrument consisting of two dry piles connected at the top and terminating at the bottom in two tiny bells close together, and composing the positive and negative poles. A minute ball is suspended between them by a silk thread. The little ball gets a charge from one bell and conveys it to the other. The electric field between the two bells is strong enough to keep the ball swinging and to make a soft but audible tinkle. It was set up in 1840, and has been ringing ever since. The energy required is very small, and is necessarily limited by the energy stored up in the materials of the pile. Dry piles constitute a transition device between a frictional machine and a voltaic cell.

183. Simple Voltaic Element. — If a strip of zinc amalgamated with mercury be placed in sulphuric acid diluted with about twenty times its volume of water, bubbles of hydrogen will collect on the zinc, but the chemical action will soon apparently cease. No change will be produced by placing a strip of clean copper in the same solution until the two metals are connected either directly or by means of some good conductor (Fig. 92). The acid then attacks the zinc, hydrogen is freely liberated

at the surface of the copper plate, and a dense solution of zinc sulphate streams down from the zinc. The liquid product of the chemical action appears at the zinc plate, and the gaseous product at the copper. As soon as the connection between the two metals is interrupted, chemical action ceases and hydrogen is no longer disengaged.

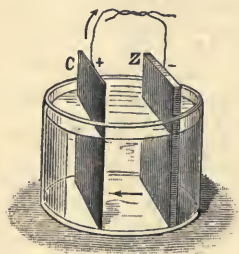

Fig. 92.

If the two plates be connected to opposite sides of a quadrant electrometer, it will be found that the zinc is negative and the copper positive. A potential difference is thus established between the two plates by immersing them in the acid solution. The copper strip is called the *positive electrode*, and the zinc the *negative*.

Such a system of two metals immersed in a liquid which acts chemically on one of them constitutes a simple *voltaic cell* or *element*. The negative electrode is usually zinc, the positive one may be copper, silver, or platinum; while for the exciting liquid Volta used water, salt water, sulphuric acid, hydrochloric acid, or a caustic alkali.

When the plates are joined by a conductor a number of new phenomena appear, which are ascribed to an electric current flowing through the conductor from the copper to the zinc, and through the liquid from the zinc to the copper. The zinc wastes away, and the energy of its union with the acid is in part given out by degrees as the energy of the electric current, which may be made to do work or to generate heat.

When a number of voltaic cells are joined together they compose a voltaic *battery*.

184. Chemical Action in the Simple Voltaic Cell. — The chain of elements in the cell is as follows :

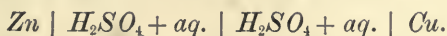

The operation, which is repeated over and over, may be indicated thus :

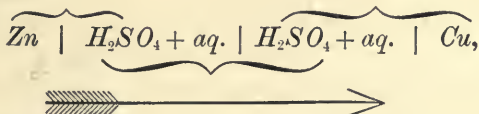

giving $\text{ZnSO}_4 + \text{aq.} \mid \text{H}_2\text{SO}_4 + \text{aq.} \mid \text{H}_2 \mid \text{Cu.}$

The arrow shows the direction of the current through the cell. The zinc and hydrogen carry positive charges in one direction, while the "sulphion," or SO_4 , carries a negative charge in the opposite direction, and the sum of these two kinds of charges carried per second is the value of the current. The dissociated atoms or molecules, such as zinc and SO_4 , are called *ions*. All metals and hydrogen are electro-positive ions; that is, they travel with the current and carry positive charges through the *electrolyte*, the liquid solution through which a current passes. An electrolyte conducts only by means of the migration of these ions, set free by electrolytic dissociation. Molecules not decomposed are electrically neutral. Only the dissociated molecules are instrumental in conducting a current. Clausius supposed that dissociation and recombination of molecules in a solution are going on continuously; but the view now acquiring prominence is that conduction by an electrolyte depends on permanent and not momentary dissociation of the positive and negative ions. According to this view the separated ions convey their electric charges with a small but calculable velocity through the electrolyte, instead of by a series of decompositions and exchanges as illustrated above.

A chemical system in which the changes of energy, associated with the changes of matter, produce a difference of electric potential is called a voltaic cell. A voltaic cell must contain an electrolyte, either a solution in water or a molten salt.

185. Electromotive Force. — Electromotive force (E.M.F.) is the cause of an electric flow. It is often expressed as an *electric pressure*, from its analogy to water pressure. Volta supposed the origin of the electromotive force of a voltaic cell to be at the contact of the zinc and copper; but while there certainly is an E.M.F. of contact, it is much too small to account for the observed E.M.F. of a voltaic cell. It is more rational to suppose that the seat of the E.M.F. is at the point where the transformation of the energy takes place; that is, at the contact of the zinc and acid. There is also an opposing E.M.F. at the contact of the copper and the acid, but the former is the larger, and the difference of the two is the effective E.M.F. of the cell.

The E.M.F. of any form of voltaic cell depends on the materials employed, and is entirely independent of the size and shape of the plates. It is modified by their oxidation and by the density of the solutions. Oxidation of the copper plate increases the E.M.F., while oxidation of the zinc plate diminishes it.

The E.M.F. of a cell is the measure of the work required to cause a unit quantity of electricity to flow round the entire circuit. If the two poles of a cell be connected with two parallel plates composing a condenser, then a momentary transfer of electricity takes place throughout the circuit, by conduction through the cell and the conductors, and as an electric displacement through the

dielectric between the plates of the condenser. The plates will then be maintained at a difference of potential, and this potential difference is equal to the electromotive force of the cell.

A voltaic cell is a device to produce E.M.F., or electric pressure. It does not generate electricity, but generates the E.M.F. which sets electricity flowing.

186. Electromotive Force and Potential Difference.

— The potential difference between the points *A* and *B* (Fig. 93) is the work which must be done in the transfer of the unit quantity of electricity from *A* to *B* through the external circuit *R*. It is often called the fall of potential from *A* to *B*. It is the part of the E.M.F. of the cell necessary to drive the given current through the external

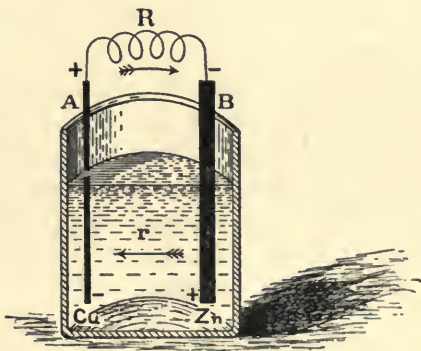

Fig. 93.

resistance *R*. Work must also be done in carrying the unit quantity from the negative terminal *B* through the cell to the positive terminal *A*. The E.M.F. of the cell is the total work expended in carrying the unit quantity round the entire circuit. Electromotive force and potential difference must not be identified. The former should be regarded as establishing the latter rather than the reverse. It is quite possible to imagine conditions under which a current may flow through a uniform conductor without any potential difference between different points

of it, but not without the existence of an E.M.F. The potential difference between any two points of a circuit is numerically equal to the E.M.F. producing the current from the one point to the other when the circuit between the points contains no source of E.M.F. The current then flows from the point of higher to the point of lower potential. In the interior of the cell the current flows across from the zinc to the liquid, or from lower to higher potential. It is forced upward by the E.M.F. which has its seat there. This E.M.F. may be compared to a pump which sets water circulating through a system of horizontal pipes against friction. In any portion of the system the force producing the flow between two points is the difference of water pressure between those points. The force is all applied, however, at the pump, and this produces the pressure throughout the system. Electricity stored up in a condenser is under pressure just as water lifted against gravity is under pressure. In both cases a flow will be produced by this pressure if the requisite conditions are supplied.

187. *Polarization.* — If the circuit of a simple voltaic element be closed the current will fall off rapidly in intensity, and will at length almost cease to flow. The hydrogen covering the copper plate as a film produces a state known as the *polarization* of the cell. Polarization is a counter E.M.F. set up by the tendency of the hydrogen to oxidize. Hydrogen, like zinc, is an electro-positive element, and produces an E.M.F. opposed to that due to the union of the zinc and the acid.

Besides generating an E.M.F., the hydrogen film introduces a resistance or obstruction to the flow of the current from the liquid to the copper. This is an additional reason for the weakening of the current.

188. Depolarization by Chemical Means. — Any device that will prevent the liberation of hydrogen and its deposit on the positive electrode will largely obviate polarization. It will not, of course, prevent the falling off in the current on account of the exhaustion of materials in immediate contact with the plates. This defect may be ascribed to the slowness with which the liquid contents of the cell diffuse.

Let a cell be made by placing in a small glass jar enough chemically clean mercury to cover the bottom, and filling with a saturated solution of common salt. Hang a plate of zinc in the liquid, and thrust into the mercury the exposed end of a rubber-covered copper wire to serve as the positive terminal. Close the circuit through some simple current indicator, such as a common telegraph sounder of a few ohms resistance. The armature will be drawn down strongly at first; but in the course of a few minutes the magnet will release it, showing that the cell has become polarized. The action of the released electro-positive sodium on water at the surface of the mercury produces sodium hydroxide and hydrogen.

Keeping the circuit closed, drop into the cell a very small piece of mercuric chloride ($HgCl_2$) no larger than the head of a pin. The armature of the sounder will be suddenly drawn down, showing recovery of the cell from polarization. The mercuric chloride furnishes chlorine atoms which unite with the hydrogen on the surface of the mercury, and so reduce the polarization. The chloride will be exhausted in a few minutes, and polarization will again ensue.¹

189. The Daniell Cell. — The first cell practically free

¹ This experiment is due to D. H. Fitch.

from polarization was the invention of Professor Daniell, of London. In this cell the liberation of hydrogen is entirely prevented by surrounding the copper plate with a saturated solution of copper sulphate ($CuSO_4$), so that

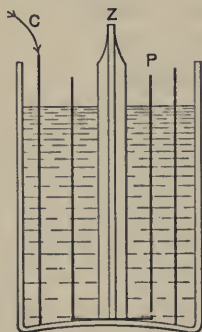
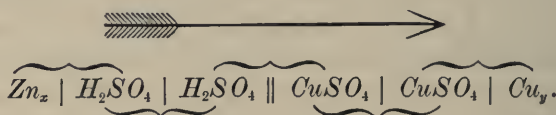

Fig. 94.

electro-positive copper instead of electro-positive hydrogen is deposited on the copper plate. A zinc bar Z (Fig. 94) is immersed in the acidulated water in an unglazed earthenware cup P ; the copper plate C is a cylinder of sheet copper surrounded with a saturated solution of $CuSO_4$. Some spare crystals of this salt should be added to supply the waste during the action of the cell. The E.M.F. of a Daniell cell is a little over one *volt*. The *volt* is the practical

unit of E.M.F. (295).

190. **Chemical Action in the Daniell Cell.** — With acidulated water the chemical processes may be represented as follows:



After the first step in the reaction this becomes

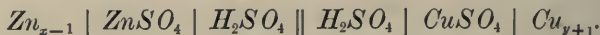

The direction of the current through the cell, indicated by the arrow, is the direction followed by the electro-positive elements, Zn , H , and Cu . They are said to *migrate* from the negative toward the positive pole.

It is better to immerse the zinc in dilute zinc sulphate

than in acidulated water. The chain of elements is then

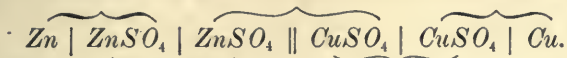

Hydrogen then takes no part in the operation. In either case, zinc enters into combination as $ZnSO_4$, and metallic copper is liberated. The zinc sulphate increases in amount and the copper sulphate decreases.

Advantage is often taken of the difference in density of the two sulphate solutions to effect a separation between them. The copper electrode is then placed in the bottom of the jar with the $CuSO_4$, and the zinc is suspended in the lighter $ZnSO_4$ near the top. Such an arrangement is known as a *gravity cell*. It must be kept at work to prevent the diffusion of the $CuSO_4$ upward as far as the zinc plates.

191. **Theory of the Production of a Current.** — A brief summary of the modern electro-chemical theory respecting a voltaic element may be reviewed with profit without committing ourselves to its truth. When a metal is immersed in a solvent, there is present an expansive force tending to drive its molecules into solution. It is analogous to the expansive force producing sublimation, and is called "*solution tension*." Opposing this force is the pressure of the dissolved atoms of the metal analogous to vapor pressure; this follows the laws of Boyle and Charles, and is called "*osmotic pressure*." Besides, all metal ions carry positive charges. Hence when a metal, like zinc, is dipped into acidulated water, containing free hydrogen and sulphion ions, electro-positive zinc atoms are driven into solution until the solution tension comes into equilibrium with the osmotic pressure and the electrostatic repulsion tending to drive these atoms out of the solution. It does drive hydrogen out against the zinc. The same process

goes on with copper, but its solution tension is less than that of zinc.

When zinc is placed in zinc sulphate and copper in copper sulphate, the two solutions being kept apart by a porous diaphragm, zinc goes into solution by its solution tension, and the resulting osmotic pressure throughout the liquid drives copper atoms out of solution till there is equilibrium, — on the copper side by the solution tension and electrostatic repulsion between the positive charge, acquired by the copper plate, and the electro-positive copper ions in the one direction, and the osmotic pressure in the other. It is assumed without apparent justification that the ions have large electrostatic capacity.

If now the circuit be closed a transfer of electricity takes place through the conductor, the equilibrium can no longer be maintained, and there is a continuous solution of zinc and a continuous reduction of copper, both these electro-positive ions carrying positive charges and thus producing an electric current. As the density of the zinc sulphate increases, the number of free zinc ions increases, with a corresponding increase of osmotic pressure. If at the same time the density of the copper sulphate decreases, the osmotic pressure on the copper ions decreases. Both actions weaken the electromotive force which drives the ions across with their charges. It is easily seen that the current consists of the existent charges which are only passed on by the moving ions. As the copper ions are driven out, the zinc ions take their places in combination with SO_4 .

192. **Chemical Action in Relation to Energy.** — It is desirable to add to the theory outlined that the chemical displacement involved is conditioned on the fact that the energy of combination of $ZnSO_4$ is greater than that of

$CuSO_4$. Hence the energy expended in decomposing $CuSO_4$ is less than that evolved in the formation of an equivalent quantity of $ZnSO_4$. The heat of formation of 65 gms. of zinc to form $ZnSO_4$ is 242,000 calories, while that of 63.4 gms. of copper, a chemically equivalent weight, to form $CuSO_4$ is 191,400 calories. The difference of 50,600 calories must be released as heat, or in the form of the kinetic energy of an electric current. The materials in the cell represent potential energy, and potential energy tends to become kinetic whenever the conditions will permit of the transformation. The sole condition in the Daniell cell is that the circuit shall be closed.

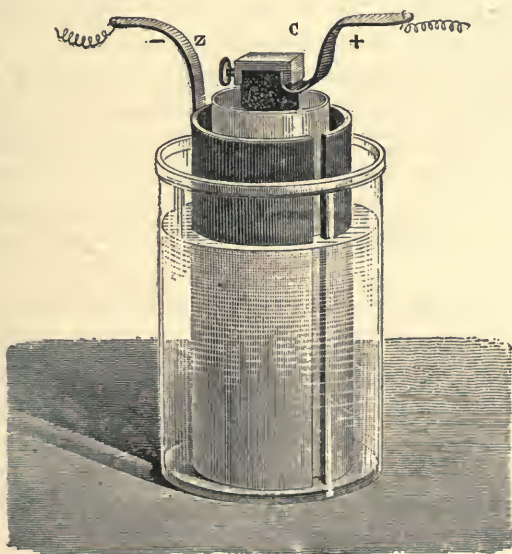

Fig. 95.

193. The Bunsen Cell. — A cleft cylinder of zinc is immersed in dilute sulphuric acid, and within a porous

cup is a prism of hard-baked carbon surrounded by strong nitric acid (Fig. 95). When the electro-positive hydrogen passes through the porous cup toward the positive electrode it encounters the nitric acid. The acid acts as a powerful depolarizer by oxidizing the hydrogen. Nitric acid is a good conductor, the E.M.F. of the cell is nearly twice as great as that of the Daniell, and a current of several amperes may be taken from it.

Bunsen's cell is a modification of Grove's, and differs from it only by the substitution of hard carbon for platinum as the positive electrode. The sole advantage of the Bunsen is in point of economy.

A useful modification of this cell, in which the corrosive nitric acid is avoided, is made by placing the zinc in the porous cup, and several carbon rods, for example, electric-light carbons, in a circle around the porous cup. The liquid in which they are immersed is a saturated solution of potassium nitrate, acidulated with about one-tenth its volume of strong sulphuric acid. Sodium or ammonium nitrate may be used instead of the potassium salt.

194. The Bichromate Cell.—This cell differs from the Bunsen only in the character of the depolarizer. If sodium (or potassium) bichromate in solution be treated with sulphuric acid, chromic acid (CrO_3) is formed. This acid is rich in oxygen and gives it up readily to nascent hydrogen. If the porous cup holding the carbon prism be filled with a strongly acid solution of the bichromate, the E.M.F. of the cell will be about the same as if nitric acid were used. Since both liquids now contain sulphuric acid, the porous cup may be dispensed with.

To prepare the solution, dissolve 200 gms. of sodium bichromate in a litre of water and add 150 c.c. of strong

sulphuric acid. When the solution begins to show signs of exhaustion, add 25 to 30 c.c. of acid per litre. The sodium salt is greatly to be preferred to the potassium salt. It dissolves more freely and without heat, and it does not form double salts with chromium, which crystallize out and are somewhat difficult of removal. The E.M.F. is about the same as that of the Grove or Bunsen.

Fig. 96 is a common form of bichromate cell, in which the zinc plate *Z* can be lifted out of the solution by the rod *a* when the cell is not in use.



Fig. 96.

195. Local Action and Amalgamation.

—The zinc of commerce contains impurities, such as bits of iron and carbon. These form local closed circuits when the zinc is immersed in an acid solution, and chemical action goes on when the circuit is open, with constant waste of zinc. This chemical action, which contributes nothing to the current from the cell, is called *local action*. The chief remedy against it is the amalgamation of the zinc by cleaning it with sulphuric acid and rubbing over the surface a little mercury. The mercury readily alloys with the zinc and forms an *amalgam*. Zincs used in an acid solution should always be amalgamated.

The immunity of amalgamated zinc from attack is due to the smooth amalgamated surface. The hydrogen is given off from it less freely than from a rough unamalgamated surface. The solution tension of amalgamated zinc is greater than that of common commercial zinc; and the former, opposed to the latter in an acid solution, forms a

negative electrode. With amalgamated zinc in dilute acid, the chemical action is soon arrested under atmospheric pressure; but if the pressure on the liquid be reduced by an air-pump, hydrogen will be freely evolved and the zinc will waste away. The liberation of hydrogen from zinc in dilute sulphuric acid, or from sodium amalgam and salt solutions, can be brought to a standstill by sufficient pressure.¹ The amalgamation of the zinc reduces the pressure necessary to arrest chemical action.



Fig. 97.

196. The Leclanché Cell. — Another class of cells employs a solid depolarizer. The most important of these from a practical point of view for working electric bells, telephone transmitters, and other like purposes, is the cell invented by Leclanché. It is a zinc-carbon couple, with a nearly saturated solution of ammonium chloride as the electrolyte, and manganese dioxide (MnO_2) as the depolarizer. The carbon electrode is packed in a porous cup

with the manganese dioxide in granules mixed with broken carbon to increase the conductivity. The zinc is a rolled rod about one centimetre in diameter. Fig. 97 shows a cell complete. The porous cup in this particular form has a flange resting on the top of the glass jar. This closes it and prevents evaporation.

If the circuit be kept closed for several minutes, the accumulation of hydrogen on the carbon plate produces polarization; but on opening the circuit again, the depo-

¹ Nernst's *Theoretical Chemistry*, Trans. by Palmer, p. 613.

larizer slowly removes it with recovery of the E.M.F. No serious local action takes place on open circuit. This cell will stand without material waste for months or even years. It is therefore well suited for domestic purposes.

197. **Chemical Action in the Leclanché Cell.**—When the circuit is closed zinc displaces ammonium from the ammoniac chloride, and the ammonium breaks up into ammonia and hydrogen, the former escaping when the cell is worked hard, and the latter being oxidized by the black oxide of manganese. Zinc chloride is formed at the expense of zinc and ammoniac chloride. When a Leclanché cell has been left undisturbed for some time, it will be found that the zinc is eaten away toward the surface of the liquid, or is cone-shaped, with the large end at the bottom. This coning is due to local action arising from a difference in the composition of the liquid at the top and bottom. The double chloride of zinc and ammonium settles down towards the bottom of the cell; and zinc in ammonium chloride is negative to zinc in this dense double salt, and wastes away slowly as the negative electrode, the lower end of the rod being the positive. There appears to be no remedy for this kind of local action. It goes on with zinc in a zinc salt if the density is greater at the bottom than at the top.

Leclanché cells are sometimes made portable by filling the space inside the cell with a spongy mass, consisting of oxide of zinc, plaster of Paris, dextrine, starch, lime, chloride of zinc, and ammonium chloride. The cell is then known as a *dry cell*.

198. **The Copper Oxide Cell.**—In general, solid depolarizers are less effective than liquid ones. But there are

two notable exceptions, oxide of copper and chloride of silver. Both of them readily give up their electro-negative ion to nascent hydrogen, and become excellent conductors by reduction of the metal.

The copper oxide cell was invented by Lalande and Chaperon. A spiral of zinc is immersed in a solution of caustic potash or soda, containing 30 to 40 parts of the alkali to 100 of water. The positive electrode is either iron or copper in contact with cupric oxide. One of the early forms is shown in Fig. 98, where *D* is the zinc spiral, *A* an iron cup containing the cupric oxide *B*, and *G* a caoutchouc tube surrounding the zinc at the surface of the liquid. The liquid is covered with a layer of heavy paraffin oil to prevent access of the carbon dioxide of the air to the caustic alkali.

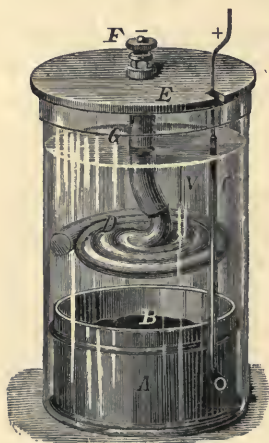

Fig. 98.

The zinc replaces hydrogen in the alkali, forming sodium zincate (Na_2ZnO_2); the ejected hydrogen, migrating with the current, abstracts oxygen from the cupric oxide, and metallic copper is reduced.

In the Edison-Lalande cell the copper-oxide is employed as a compressed plate held in a copper frame. Such a plate may be made by mixing cupric oxide with five or ten per cent of magnesium chloride and heating the thick mass in an iron mould.

199. The Silver Chloride Cell. — The metallic elements are zinc and silver, and on the silver is cast silver chloride as the depolarizer. The exciting liquid or elec-

trolyte is a dilute solution of ammoniac chloride containing 23 gms. to the litre of distilled water. A denser solution dissolves silver chloride. In this cell, as made by Warren de la Rue, the silver wire and its chloride were surrounded by a small cylinder of parchment paper to prevent internal short-circuits. The zinc rod and silver wire were held in a paraffin stopper, and the cells were connected in series by wedging the silver wire of one cell into the zinc rod of the next (Fig. 99).

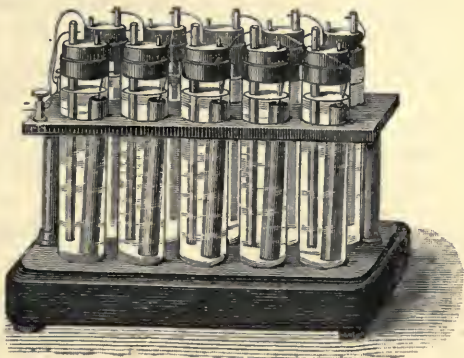

Fig. 99.

By joining 15,000 of these cells in series, de la Rue performed many of the experiments usually conducted by means of an influence machine. This cell polarizes but slightly and recovers promptly, but it can be used for small currents only.

200. The Clark Standard Cell. — The E.M.F. of the Daniell cell is more nearly constant than that of any of the others thus far described. The cell first made by Latimer Clark, and since investigated by many physicists, has a perfectly constant E.M.F., if set up and used in accordance with specifications which have received national approval.¹ The cell has now been adopted as an international standard of E.M.F.

The negative electrode is either pure zinc or a 10 per

¹ Carhart and Patterson's *Electrical Measurements*, p. 176.

cent amalgam in a neutral saturated solution of zinc sulphate, and the positive electrode is pure mercury in contact with a paste of mercurous sulphate. The cell must contain zinc sulphate crystals in excess. A portable

form is shown in Fig. 100, in which the contents are kept from mixing by the asbestos fibre and the form of the zinc. Its E.M.F. is 1.434 volts at 15° C. It diminishes by about 0.001 volt per degree rise of temperature between 10° and 25° C.

Von Helmholtz, in 1882, suggested the substitution of the chlorides of zinc and mercury for the sulphates. The E.M.F. is then lower, and may be made exactly one volt by adjusting the density of the zinc chloride

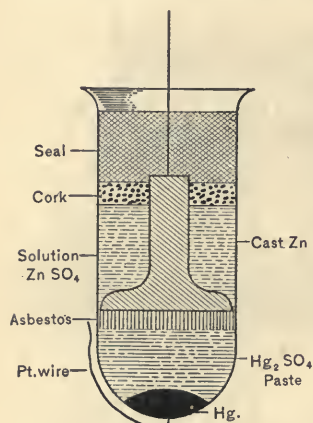

Fig. 100.

solution. The temperature coefficient is only about one-eighth as large as that of the Clark cell containing excess of zinc sulphate crystals.

Weston has modified the Clark cell by substituting cadmium and cadmium sulphate for zinc and its sulphate. The E.M.F. is then slightly above one volt, and the variation with temperature is very small.

201. Data relating to Cells. — It is convenient to collect in tabular form the following data relating to the cells described :

Cell.	Negative electrode.	Exeltant.	Depolarizer.	Positive electrode.	Approximate volts.
Volta	Zinc	$H_2SO_4+aq.$	Copper	1.0
Danlell	"	$ZnSO_4+aq.$	$CuSO_4+aq.$	"	1.1
Bunsen	"	$H_2SO_4+aq.$	HNO_3	Carbon	1.9
Grove	"	" "	"	Platinum	1.9
Zinc-carbon	"	" "	$NaNO_3+H_2SO_4$	Carbon	1.8
Biehromate	"	" "	$Na_2Cr_2O_7+H_2SO_4$	"	1.9
Leelanché	"	$NH_4Cl+aq.$	MnO_2	"	1.5
Lalande	"	$NaOH$	CuO	Copper	0.8
Silver chloride,	"	$NH_4Cl+aq.$	$AgCl$	Silver	1.1
Clark	"	$ZnSO_4+aq.$	Hg_2SO_4	Mereury	1.434
Calomel	"	$ZnCl_2+aq.$	Hg_2Cl_2	"	1.0
Weston	Cadmium	$CdSO_4+aq.$	Hg_2SO_4	"	1.022

202. Effects of Heat on Voltaic Cells. — Two different effects are produced by heating a voltaic cell. The resistance of the liquid to the passage of the current is lessened, and the E.M.F. suffers a small change, either an increase or a decrease.

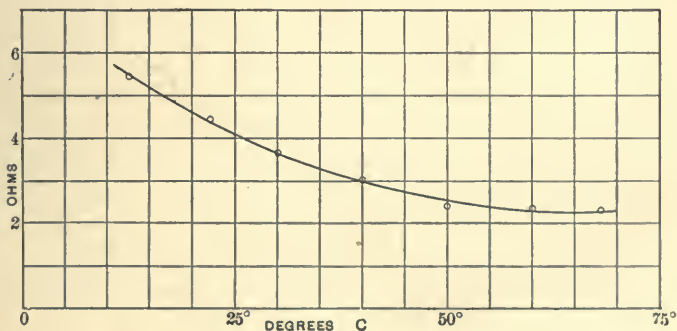

Fig. 101.

Professor Daniell found that a larger current was obtained from his cell when he heated it to 100° C. This result is due to the fact that the relative decrease in the internal resistance of the cell is much larger than the relative diminution in the E.M.F. The curve in Fig. 101

shows the relation between the internal resistance and the temperature of a Daniell cell between 15° and 68° C. The resistance is reduced to less than one-half its initial value.

The temperature coefficient of a Daniell cell is only about 0.007 per cent; that is, the E.M.F. falls 0.007 volt for 100° rise of temperature. The Clark standard has a larger coefficient. Its E.M.F. at any temperature t may be found from the formula,

$$E = 1.434 \{ 1 - 0.00077 (t - 15) \} \text{ volts.}$$

The temperature coefficient of a calomel (von Helmholtz) cell is positive, and only about 0.01 per cent for one degree C.

CHAPTER XVII.

ELECTROLYSIS.

203. **Electrolytes.** — Metals, carbon, and some other substances conduct electric currents without any perceptible effect on them except an elevation of temperature, due to the resistance which they offer. But chemically compound liquids conduct only by undergoing decomposition. If, for example, a current passes between two platinum plates immersed in dilute sulphuric acid, chemical decomposition takes place, oxygen is liberated at the platinum plate by which the current enters the solution and hydrogen at the plate by which it leaves. This process of decomposition by an electric current is called *electrolysis*, and the substance undergoing decomposition or dissociation is an *electrolyte*. Electrolytes may be solids, liquids, or even gases. Iodide of silver is an example of a solid electrolyte; while dilute acids, solutions of metallic salts and alkalis, and some fused solid compounds are examples of liquid electrolytes.

The conductors by which the current enters and leaves the liquid are called *electrodes* — the former the *anode* and the latter the *cathode*.

The ions into which a substance is divided by the current are called *anions* when they appear at the anode, and *cations* at the cathode. Hydrogen and the metals always appear at the cathode; that is, they travel with the current or are electro-positive.

204. **Electrolysis of Water.**—Perfectly pure water does not appear to conduct electricity at all. But if it be acidulated with a small quantity of sulphuric acid, it is decomposed as a secondary action. In Hofmann's apparatus (Fig. 102) the acidulated water is poured into the bulb at the top, and the air escapes by the glass taps till the tubes are filled. If the taps are then closed and an electromotive force of three or more volts be applied to the two pieces of platinum foil at the bottom, bubbles of gas will be seen to rise from them. The gases collect in the two tubes and may be examined as they escape through the taps. Oxygen will be found at the electrode at which the current enters the apparatus, and hydrogen at the other.

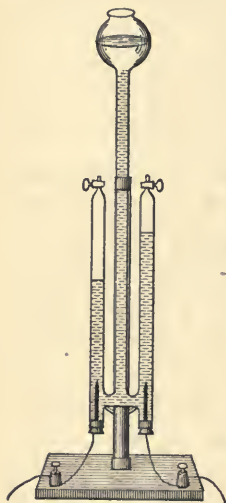
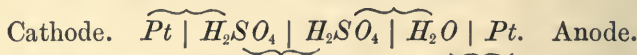

Fig. 102.

The volume of the hydrogen is not exactly twice that of the oxygen, because the latter is more soluble in water than the former, and about one per cent of it is evolved in the denser form of ozone; on the other hand, more hydrogen than oxygen is absorbed or occluded by the platinum electrodes.

The chemical reactions may be represented, without reference to the theory of the operation, as follows :



The primary electrolysis is that of sulphuric acid, while the water is decomposed at the end of the chain by the SO_4 . As often as one atom of oxygen is set free at the anode, two of hydrogen are liberated at the cathode.

205. **Electrolysis of Copper Sulphate.** — Copper sulphate presents one of the simplest cases of electrolysis. Suppose the electrodes to be copper; the passage of the current then simply transfers copper from the anode to the cathode.



There is no change in the density of the whole solution; the copper ions migrate toward the cathode and the SO_4 ions toward the anode.

If platinum electrodes are used, copper will be deposited on the cathode, and the SO_4 at the anode will decompose water and release oxygen with the formation of H_2SO_4 .

206. **Electrolysis of Sodium Sulphate.** — A salt of one of the alkaline metals presents some secondary reactions of interest. With a solution of sodium sulphate free sodium cannot exist in water at the cathode, but unites with water, forming sodium hydroxide and hydrogen; at the anode the SO_4 decomposes water, as in the other cases, and liberates oxygen.

Let the solution be placed in a flat glass tank with a non-conducting partition a extending nearly to the bottom (Fig.

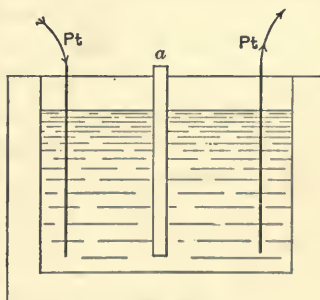

Fig. 103.

103). Add to the solution a little extract of purple cabbage. When the current is passed the liquid will turn red at the anode and green at the cathode, the former color being due to the acid formed, and the latter to the

alkali. Stop the flow of the current and mix the liquids on the two sides of the partition; both the red and the green colors will disappear with the restoration of the faint purple, showing that the acid and the alkali were produced in chemically equivalent quantities which neutralize each other. The final result is the decomposition of water.

207. Electrolysis of Lead Acetate. — Place the solution, which may be made clear by the addition of a small quantity of acetic acid, in a flat glass tank and electrolyze between two lead wires. The lead separated from the clear solution will be deposited on the cathode in the form of shining crystals, which will grow rapidly, giving rise to what is known as the “lead tree.” If the process is not conducted too rapidly, these crystals will assume very beautiful forms. The lead goes into solution at one electrode and comes out of solution at the other.

After a few minutes reverse the current; the first crystalline deposit will gradually disappear, and another one will form on the other wire. In this way the disappearance of the lead at the one electrode and its appearance at the other may both be observed at the same time. The reaction is precisely like that of copper sulphate between copper electrodes.

Cathode. $\overbrace{Pb} \mid \overbrace{Pb (C_2H_3O_2)_2} \mid \overbrace{Pb (C_2H_3O_2)_2} \mid \overbrace{Pb}$. Anode.



208. Quantitative Laws of Electrolysis. — Faraday showed that the masses of the ions separated are connected by a very simple relation with the quantity of electricity which passes through the electrolyte. This relation is expressed by the following laws:

I. The mass of an electrolyte decomposed by the passage of an electric current is directly proportional to the quantity of electricity that passes through it.

If the current be kept constant, the mass of the ion liberated in a given time will be directly proportional to the strength of the current.

II. If the same quantity of electricity passes through different electrolytes, the masses of the different ions liberated at the electrodes are proportional to their chemical equivalents.

Thus, if the same current passes through a series of electrolytic cells, in which it liberates as ions hydrogen, chlorine, copper, and silver, then for every gramme of hydrogen set free, 35.46 gms. of chlorine, 31.7 of copper, and 107.9 of silver will be separated.

The electro-chemical equivalent of an ion is the number of grammes of it deposited by the passage of unit quantity of electricity. When the current has unit strength, unit quantity flows through any cross-section of the conductor in one second of time. Faraday's laws may then be combined in the statement that the number of grammes of an ion deposited by the passage of a current through an electrolyte is equal to the continued product of the strength of the current, the time in seconds during which it flows, and the electro-chemical equivalent of the ion.

209. Electro-chemical Equivalents. — The electro-chemical equivalents of the several ions are proportional to the relative masses of them which take part in equivalent chemical reactions. The electro-chemical equivalents of those ions which have a valency of one are proportional to their atomic weights, and to half the atomic weights if the ions have a valency of two. Elements which form two

series of salts, such as copper in cupric and cuprous salts, and mercury in mercuric and mercurous salts, have different electro-chemical equivalents according as they are deposited from solution of cupric or cuprous, mercuric or mercurous salts.

The following table of electro-chemical equivalents is based on the practical unit of quantity of electricity called the *coulomb*, which is one-tenth the C.G.S. electromagnetic unit of quantity (see Chapter XXI.):

Ion.	Atomic weight.	Chemical equivalent.	Electro-chemical equivalent in grammes per coulomb.
Hydrogen	1	1	0.00010362
Sodium	23	23	0.0002383
Potassium	39.03	39.03	0.0004044
Silver	107.92	107.92	0.0011180
Copper (cupric)	63.4	31.7	0.0003285
“ (cuprous)	63.4	63.4	0.0006570
Mercury (mercuric)	199.8	99.9	0.0010352
“ (mercurous)	199.8	199.8	0.0020704
Iron (ferric)	55.9	18.64	0.0001932
“ (ferrous)	55.9	27.95	0.0002898
Nickel	58.6	29.3	0.0003043
Zinc	65	32.5	0.0003370
Oxygen	15.96	7.98	0.0000827
Chlorine	35.46	35.46	0.0000367
Iodine	126.85	126.85	0.0013143

210. The Silver Voltmeter. — If a neutral 15 per cent solution of silver nitrate ($AgNO_3$) is electrolyzed between a silver anode and a platinum cathode, or between two silver electrodes, silver is transferred with the current, and is deposited on the cathode as adherent crystals if the electrode be of sufficient size. Silver is removed from the anode by the acid radical NO_3 as fast as it is deposited on the cathode. The uniform results obtained in the electrol-

ysis of silver nitrate have led to its adoption as a standard method for the measurement of a current. When applied to this purpose an electrolytic apparatus is called a *voltameter*.

A convenient form of silver voltameter is shown in Fig. 104. The middle silver plate is the cathode, and the two outer ones together constitute the anode. They are attached by spring clamps to terminals affixed to an insulating support; the whole can be removed from the solution by loosening the screw *B*. A rack and pinion, worked by means

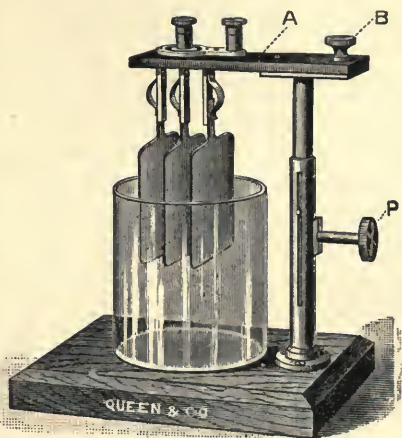

Fig. 104.

of the milled head *P*, allows the plates to be adjusted to a greater or less depth of immersion. The anode plates must be of pure silver.

The practical unit of current strength is the *ampere*. Its electro-magnetic definition will be given later. A current has the strength of one ampere when it deposits silver at the rate of 0.001118 gm. per second, or 4.025 gms. per hour. The mass of silver deposited in *t* seconds by a current of *I* amperes is

$$m = Izt,$$

where *z* is the electro-chemical equivalent. Hence

$$I = \frac{m}{zt}.$$

The divisor in this expression may be 4.025 multiplied by the time of deposit expressed in hours.

211. The Copper Voltameter. — The silver voltameter is not employed for currents much larger than one ampere; for larger currents the copper voltameter is used. It consists of smooth copper plates immersed in a solution of copper sulphate acidulated with a few drops of sulphuric acid. The electro-chemical equivalent of copper (cupric) is less than one-third that of silver; for the same current the weight of copper deposited in a given time is therefore correspondingly less. The results are not so uniform as those secured by silver nitrate, the practical electro-chemical equivalent being a function of the temperature and the density of the current at the cathode. By density of current is meant the fraction of an ampere per square centimetre of cathode surface. It is commonly expressed reciprocally as the number of square centimetres per ampere.

212. Reversibility of the Daniell Cell. — When a current flows from zinc to copper through a Daniell cell, zinc is dissolved and copper is deposited. The E.M.F. of the cell operating in this way as a generator is about 1.1 volts. Suppose now an opposing E.M.F. greater than 1.1 volts be applied to the terminals of the cell. The copper then becomes the anode and the zinc the cathode, or the cell is worked backwards. When the cell is worked forwards as a generator, the electro-positive ions travel toward the copper plate, as represented in the upper diagram of Fig. 105; the cell is then giving out energy in the form of an electric current, with a corresponding loss in its store of potential energy. Suppose this process to continue till

one gramme-equivalent (65 gms.) of zinc has been dissolved, and one gramme-equivalent (63.4 gms.) of copper has been deposited. Then let the cell be worked backwards with the reactions of the lower diagram of Fig. 105; the cell is then receiving energy, and storing it up in the increase of zinc and CuSO_4 at the expense of copper and ZnSO_4 . When a gramme-equivalent of copper has been

removed from the copper plate and a gramme-equivalent of zinc has been deposited on the zinc plate, the cell is in its initial state. There has been no loss of materials, and they are in the same chemical condition as at the outset. Except for the small loss by heat due to resistance, the energy given out by the cell during the direct action equals the energy stored up during the reversal of its

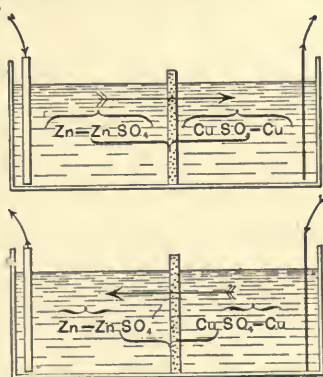

Fig. 105.

functions. Hence during the direct action as a generator there can be no counter E.M.F. to work against to prevent the conversion of the potential energy of the cell into the energy of an electric current. This cell is therefore completely *reversible* and does not polarize.

The simple voltaic element belongs to another class. Suppose it to work forwards till an equivalent of hydrogen has been given off at the copper and an equivalent of zinc has gone into solution. Then let it be worked backwards till an equivalent of copper has gone into solution and an equivalent of hydrogen has been given off at the zinc. At the end of the experiment an equivalent of both zinc and copper has gone into solution and two equivalents of

hydrogen have been set free. The cell does not return to its initial state at the end of the experiment, and there must be a compensation for the net chemical changes.¹ This compensation is found in the counter E.M.F. of polarization when the cell works forward as a generator. The simple voltaic element is an example of a *non-reversible* or polarizable cell. Only reversible elements work with maximum efficiency.

213. **Polarization of an Electrolytic Cell.** — If the two platinum electrodes of Hofmann's apparatus (Fig. 102) be connected to a sensitive gal-

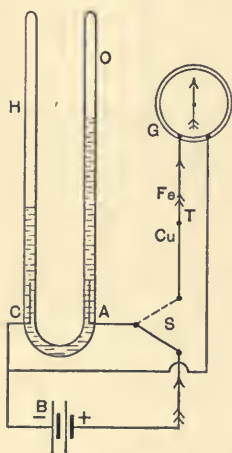

Fig. 106.

vanometer immediately after they have been used for the electrolysis of sulphuric acid, it will be found that energy has been stored up to some extent and the cell will furnish a current. The chemical and electrical functions are now reversed; the hydrogen and oxygen on the electrodes unite to form water, and a reverse current flows through the cell. The apparatus may be set up as in Fig. 106. *B* is the battery to furnish the current to decompose the sulphuric acid. Hydrogen accumulates in the tube *H* and oxygen in the tube *O*.

Let the two-point switch *S* be now turned so as to cut off the battery and to join the electrolytic cell to the galvanometer *G*. The needle will be sharply deflected by the current from the Hofmann's apparatus. To determine its direction, a thermal couple, consisting merely of a

¹Nernst's *Theoretical Chemistry*, Trans. by Palmer, p. 597.

copper and an iron wire soldered together and placed in the circuit of the galvanometer at T , is convenient. When such a couple is slightly heated a current passes across from Cu to Fe . It may be tried before charging the electrolytic cell, and the direction of the deflection of the galvanometer may be noted. It will then be found that the current produced by the electrolytic cell will flow out from A and in at C , or in the reverse direction to the current which separates the gases, oxygen and hydrogen. The E.M.F. of polarization is therefore a back or resisting E.M.F.

214. **Electrolysis with and without Polarization.** — When electrolysis takes place between two metallic plates of the same kind, immersed in a salt of the same metal, the polarization of the electrodes is very small. Thus, with copper in copper sulphate, or zinc in zinc sulphate, or silver in silver nitrate, the polarization is slight; the small counter E.M.F. exhibited is probably due to a difference in the surface of the anode and cathode, and to a difference in the density of the solutions in immediate proximity to the plates. Zinc in zinc sulphate shows no appreciable polarization.

But when the electrolysis effects a change in the chemical composition of the electrolyte, polarization results. The ions set free, such as hydrogen and oxygen, have a tendency to reunite by means of a reverse current and a reverse chain of molecular interchanges. In such cases work is done during electrolysis, and potential energy is stored up in the form of chemical separations.

In the first kind, where the metal is simply transferred from one electrode to the other, a very weak E.M.F. is sufficient to produce electrolysis; in the second, the applied

E.M.F. must exceed the counter E.M.F. of polarization before visible separation of the ions is accomplished.

215. Grove's Gas Battery. — Grove's gas battery is constructed on the basis of the facts just described. The platinum strips are fused into the tops of the two tubes (Fig. 107), which are fitted into two necks of a Woulff's bottle filled with dilute sulphuric acid. After the tube *H* has been nearly filled with hydrogen by electrolysis, the terminals *P* and *N* become respectively the positive and negative of a voltaic element. The surfaces of the platinum plates are covered with platinum black for the purpose of increasing the surface of the liquid in contact with platinum.

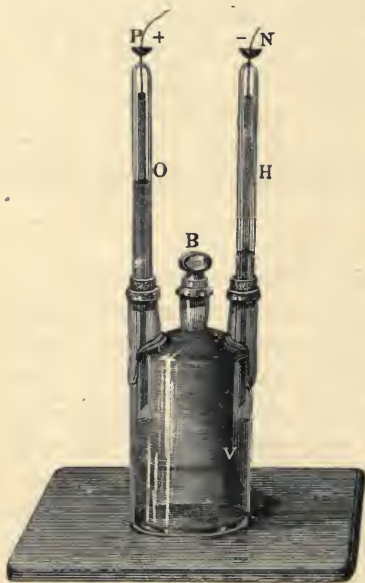
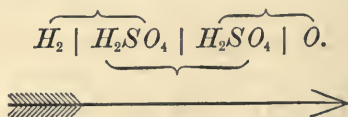

Fig. 107.

The action may be represented thus:



After the first exchange of atoms this becomes



Water is re-formed at the expense of the oxygen and hydrogen. The water or sulphuric acid voltameter is therefore

a reversible element. Similar results may be obtained with other gases, notably hydrogen and chlorine.

216. **Planté's Storage Cell.** — If the platinum electrodes of the sulphuric acid voltameter be replaced by lead, we have the Planté storage cell, which is the basis of all modern storage batteries. Take two pieces of sheet lead and solder to each a short length of copper wire as a terminal. Attach the lead strips to opposite sides of a block of dry wood, and immerse the plates in dilute sulphuric acid (Fig. 108). Pass a current through the cell for a few minutes. The oxygen liberated at the anode will oxidize the lead, forming a dark-brown coating of the peroxide of lead. An ordinary electric house-bell may be connected with the cell by a switch, as in Fig. 106. When the switch is turned, cutting off the charging battery and connecting the lead electrolytic cell with the bell, the latter will ring vigorously for a few seconds. The operation may be repeated, showing that energy is stored up in the cell by the process of electrolysis. The E.M.F. of polarization in this case is somewhat over two volts. Planté subjected his cells to repeated charging in opposite directions, so that both plates should be modified to an appreciable depth by alternate oxidation and reduction. This process was called "forming" the plates.

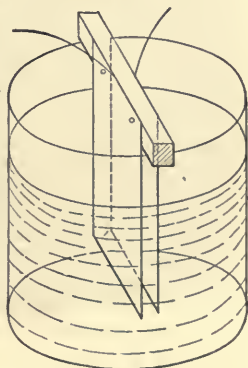

Fig. 108.

In most modern storage cells the plates, cast or rolled in the form of grids, are provided with lead oxides which compose the "active material." These oxides are changed

into peroxide at the anode, and reduced by hydrogen to spongy lead at the cathode during the operation of charging.



Fig. 109.

The chemical reactions of the storage cell are very complex, and are to some extent undetermined. Sulphuric acid is formed during the charging of the cell, and disappears during the discharge. Some sulphate of lead is also formed during the discharge, and is reduced by hydrogen with slow charging. The electrode which is the anode when charging and the cathode when discharging is called the positive pole of the cell. Fig. 109 represents a cell of the "chloride accumulator."

217. Theory of Electrolysis.

— Many reasons have been adduced which go to show that dissociation of acids and salts takes place when they are dissolved in water. Hydrochloric acid, for example, is dissociated into positive hydrogen and negative chlorine; sulphuric acid into two positive hydrogen atoms and the negative acid radical SO_4 . This dissociation, if it actually occurs, is intimately connected with the conduction of electricity by electrolytes. Clausius proposed the theory that momentary dissociations occur with succeeding recombinations, a process of intermolecular exchanges; and that the electric current determines only the direction in which such exchanges shall take place. Such transient dissociation would suffice to account for the observed conduction of very small cur-

rents by electrolytes without any visible separation of free ions; but it is incompetent to explain other facts of physical chemistry. This phenomenon of partial electrolysis von Helmholtz called *electrolytic convection*, and assumed that it takes place by the agency of the uncombined atoms in the liquid. The modern theory makes all electrolytic conduction depend upon these dissociated atoms.

If gaseous hydrochloric acid be introduced between platinum electrodes connected with a voltaic battery, no appreciable transfer of electricity occurs; neither does *pure* water conduct electricity; but if the hydrochloric acid be dissolved in water, the solution becomes conducting, with the electrolytic separation of hydrogen and chlorine. The inference is justifiable that the acid must have undergone an important molecular change by solution in water, because after solution it conducts electricity, and before solution it does not. The same inference does not apply to the solvent, because it does not suffer electrolytic decomposition. The molecular change which the acid undergoes by solution is dissociation into electro-positive and electro-negative ions, thus:

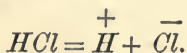

The capacity of a dissolved substance to conduct electricity therefore presupposes a molecular cleavage into positively and negatively charged atoms. The larger the number of such dissociated molecules in a solution, the better it conducts. It is not necessary that all the molecules of the substance be dissociated by the solvent. Those that are not decomposed remain electrically neutral and take no part in the transfer of electricity.

Let the cell in Fig. 110 contain a water solution of hydrochloric acid with platinum electrodes. These elec-

trodes are charged as shown by connection with a battery, which maintains a constant potential difference between

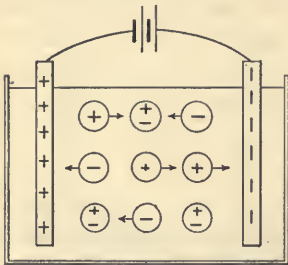

Fig. 110.

them. The solution contains positively charged hydrogen atoms and negatively charged chlorine atoms, besides neutral molecules which have not been decomposed. Then the positive charge on the anode attracts the negative chlorine atoms and repels the positive hydrogen atoms, while the reverse actions occur at the negatively

charged cathode. All these forces combine to produce a simultaneous and equal procession of hydrogen atoms from anode to cathode, and of chlorine atoms from cathode to anode. This double procession of free ions with their electric charges represents the passage of an electric current through an electrolyte.

218. Electrolysis in the Arts. — Electrolysis is now employed on a large scale for a number of distinct purposes in the arts and industries. These may be classed under four heads, viz., the reduction of metals from their ores or solutions; the copying of types, casts, woodcuts, and metal work; the covering of objects in base metals with gold, silver, or nickel; and the manufacture of various chemicals, such as caustic soda, bleaching liquors, and chlorate of potassium. The first three of these are included under the general term of *electro-metallurgy*.

Pure copper is now produced on an enormous scale by electro-deposition. After a second process of reduction in a blast furnace the "blister" copper, containing small quantities of gold, silver, oxide of iron, and sulphides, is

cast into slabs which serve as the anode plates in the electrolytic bath of copper sulphate. Several plants are now in operation in the United States, with a capacity of from 50 to 100 tons of pure copper daily.

Aluminium is reduced in large quantities from a fused mixture of electrolytes. Cryolite, a double fluoride of aluminium and sodium, is first fused by the passage of a very large current between huge carbon electrodes. To this fused mass is added bauxite, a ferruginous hydrate of aluminium, and this is dissolved by the fused cryolite. The cryolite serves as the bath and the aluminium oxide is electrolyzed. Its solution produces a marked reduction in the resistance of the bath. Only a small per cent of the cryolite is decomposed.

If copper is deposited on any surface, such as coins, ornaments, and stereotype plates, an exact impression is obtained in reverse relief. If a mould in plaster or wax be taken of any object, and be covered with a conducting film of plumbago or finely powdered bronze, the mould can be coated with a deposit of copper. When this is filled with type metal, an exact reproduction of the original is obtained. This process is largely employed to reproduce repoussé and other works of art in facsimile, and to multiply copies of woodcuts or other engravings for printing. The electrolytic solution is acidulated copper sulphate.

The art of electro-plating was invented early in the present century. The objects to be covered with a thin deposit of gold, silver, or nickel must first be made chemically clean; they are then hung in the bath as the cathode. For gold and silver plating the solution is cyanide of gold or silver dissolved in cyanide of potassium; for nickel it is a double sulphate of nickel and ammonium. The

anode in each case must be a plate of the same metal as the one to be deposited at the cathode. The solution then continues to have the same density.

PROBLEMS.

1. The weight of a cathode silver plate was 30.3726 gms. before the deposit on it and 30.4685 gms. after deposition, which lasted half an hour. Find the average current in amperes.

2. The following data are taken from a copper voltameter measurement:

Weight of cathode before deposit	83.4925 gms.
“ “ “ after “	84.4475 “

Time of deposit, 30 min.

Find the mean current.

3. The silver deposited in a silver voltameter in 45 min. was 2.8095 gms. Find the average current.

4. A current of 1 ampere is sent through three electrolytic cells in series for 30 min. The first contains cyanide of silver dissolved in cyanide of potassium; the second, zinc sulphate; the third, nickel sulphate. Find the weight of metal deposited in each.

5. If one litre of hydrogen under standard conditions weighs 0.08987 gm., how many amperes will liberate 250 c.c. of hydrogen in 10 m. 22 s.?

CHAPTER XVIII.

OHM'S LAW AND ITS APPLICATIONS.

219. *Ohm's Law.* — The relation between the electromotive force and the current was first enunciated by Dr. G. S. Ohm, of Berlin, in 1827. It has since been known as *Ohm's Law*.

If E be the E.M.F. between two points of a conductor and I the current flowing through it, then if suitable units be chosen,

$$E = RI,$$

where R is a quantity called the *resistance* of the conductor; it is independent of the value and direction of the current flowing, and depends only on the material of the conductor, its length and sectional area, its temperature and state of strain.

The above equation is an expression of Ohm's law; it is usually written in the equivalent form,

$$I = \frac{E}{R}.$$

If the practical units now adopted internationally be employed, this law may be expressed by saying that the number of *amperes* flowing through a circuit is equal to the number of *volts* of electromotive force *divided* by the number of *ohms* of resistance.

When this formula is applied to the entire circuit, which may contain several sources of E.M.F. of different signs,

and both metallic and electrolytic resistances, it is not quite so simple to apply. There are then several electromotive forces, some tending to produce a flow in one direction and some in the other; and a number of different resistances each obstructing the flow, whether it takes place in one direction or the other. Then

$$I = \frac{E_1 + E_2 + E_3 + \dots}{R_1 + R_2 + R_3 + \dots} = \frac{\sum E}{\sum R}.$$

Each E.M.F. must be taken with its proper sign. Resistance is not a directed quantity. If, for example, there are several voltaic cells in the circuit, some of them may be connected in the wrong direction so that they oppose the current; or the circuit may include electrolytic or storage cells or motors, which offer resistance in the form of a counter E.M.F. All such electromotive forces must be reckoned as negative.

220. Resistance.—Resistance is that property of a conductor in virtue of which the energy of a current is converted into heat. It is independent of the direction of the current, and the transformation into heat occasioned by it is an irreversible one; that is, there is no tendency for the heat-energy to revert to the energy of an electric current.

The practical unit of resistance is the *ohm*. It is represented by the resistance offered to an unvarying electric current by a column of mercury at the temperature of melting ice, 14.4521 grammes in mass, of a constant cross-sectional area and of a length of 106.3 centimetres. This statement is equivalent to a cross-sectional area of one square millimetre.

221. **Laws of Resistance.** — The resistances of diverse conductors are found to conform to the following laws :

(1) The resistance of a uniform conductor is directly proportional to its length.

(2) The resistance of a uniform conductor is inversely proportional to its cross-sectional area. The resistances of round wires are therefore inversely proportional to the squares of their diameters.

(3) The resistance of a uniform conductor of given length and cross-section depends upon the material of which it consists. This property is called its *specific resistance*.

222. **Specific Resistance.** — A definite meaning may be given to specific resistance by conceiving the material to be in the form of a centimetre cube (Fig. 111), a cube whose edges are 1 cm. in length. The specific resistance is the resistance which this cube opposes to the passage of a current from one face a to the opposite one b . If the conductor is a cylinder 1 cm. long with parallel ends of one square centimetre area, the resistance from a to b is the same as that of the cube. The specific resistance may be represented by s . Then the following formula expresses all the laws of resistance :

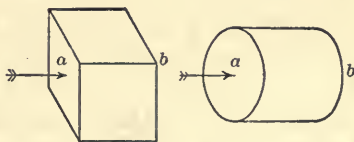

Fig. III.

$$r = \frac{ls}{a},$$

where l is the length of the conductor in centimetres, and a its sectional area in square centimetres. A table of specific resistances is given in the Appendix, Table IV.

223. **Conductivity.** — The inverse of a resistance is called *conductivity*, or sometimes *conductance*. A conductor whose resistance is r ohms has a conductivity equal to $1/r$. When a number of conductors are joined in parallel with

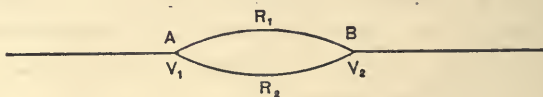

Fig. 112.

one another, the conductivity of the whole is the sum of their several conductivities. Let two conductors of resistances r_1 and r_2 be joined in parallel between the points A and B (Fig. 112). Let V_1 and V_2 be the potentials of A and B respectively. Then since $V_1 - V_2$ equals the E.M.F., we have by Ohm's law

$$\frac{E}{r} = \frac{E}{r_1} + \frac{E}{r_2}.$$

The first member of this equation is the total current, which is equal to the sum of the currents through the two branches; and r is the combined resistance of the two conductors in parallel. Hence

$$\frac{1}{r} = \frac{1}{r_1} + \frac{1}{r_2}.$$

Similar reasoning applies to any number of parallel conductors.

From the last equation,

$$r = \frac{r_1 r_2}{r_1 + r_2}.$$

224. **Effect of Heat on Resistance.** — The resistance of metallic conductors in general increases when the tem-

perature rises. If R_0 is the resistance of a conductor at 0° C. and R_t at t° C., then the equation

$$R_t = R_0 (1 + at)$$

expresses the relation between the two through a considerable range of temperature. The constant a is called the temperature coefficient. For most pure metals it is about 0.4 per cent for one degree C., or 40 per cent for a range of 100 degrees of temperature. The temperature coefficient for pure copper between 20° and 250° C. was found by Kennelly and Fessenden to be 0.00406. Dewar and Fleming have measured the resistances of pure metals in liquid oxygen at temperatures of -182° and -197° C., and have shown that the resistance of all of them decreases with fall of temperature as if it would become zero at -273° C., the zero of the absolute scale. They would then offer no obstruction to the passage of a current, however great. Pure copper is the best known conductor, but it is only slightly better than silver.

The temperature coefficient of alloys is smaller than that of pure metals. German silver has a coefficient only about one-tenth as great as that of copper; while that of platinoid is only one-half as great as that of German silver. Manganin, an alloy of manganese, copper, and nickel, has at certain temperatures a small negative temperature coefficient; that is, its resistance diminishes slightly as the temperature rises.

The resistance of carbon and of electrolytes decreases when the temperature rises. Thus, the resistance of an incandescent lamp filament is only about half as great at normal incandescence as when cold. Solutions of $ZnSO_4$ and of $CuSO_4$ have a temperature coefficient somewhat over 0.02, or 2 per cent for one degree C.

225. Loss of Potential proportional to Resistance.

— If V_1 and V_2 are the potentials of two points A and B on a conductor, then by Ohm's law

$$V_1 - V_2 = RI.$$

It is obvious from this equation that the potential difference between any two points on a conductor through which a constant current is flowing is proportional to the resistance between them, provided the conductor is not the seat of an E.M.F. Even when electromotive forces are encountered, the *loss* of potential, when a given current flows through a resistance, is proportional to that resistance.

If another point be taken between A and B so situated that the resistance between it and B is one-half the resistance between A and B , then the potential difference between this point and B is also reduced in the same ratio.

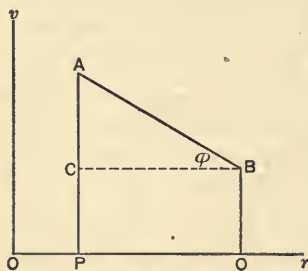

Fig. 113.

Let the distances measured along Or represent resistances (Fig. 113), and those along Or , potentials. Then AP equals V_1 and BQ , V_2 ; also PQ stands for the resistance R between the points A and B on the conductor. Join A and B and let BC be drawn parallel to Or ; then will AC be equal to $V_1 - V_2$, the potential difference between the points A and B . The slope of the line AB represents the rate at which the potential drops along the resistance R . Moreover, since

$$\tan \phi = AC / BC = E / R = I,$$

it is evident that the tangent of the angle of slope equals the strength of the current.

The principle that the loss of potential is proportional to the resistance passed over, when the current is constant, is one of very frequent application in electrical measurements.

226. Wheatstone's Bridge. — The instrument known as a Wheatstone's bridge illustrates the use made of the principle of the last article. It is a combination of resistances more commonly used than any other method for the comparison of two of them. It consists of six conductors connecting four points; in one of these conductors is a source of E.M.F., and in another branch is a galvanometer, or sensitive current detector.

Let A, B, C, D (Fig. 114), be the four points, B' the battery, and G the galvanometer. Then since the fall of potential between A and D is the same by the path ABD as by ACD , there must be a point B on the former which has the same potential as the point C on the latter. If the

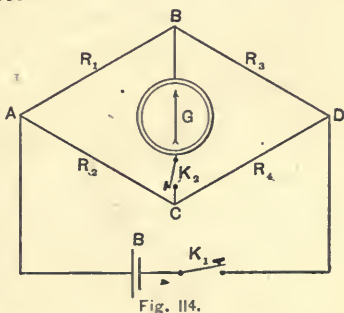

circuit through the galvanometer is made to connect these two equipotential points, no current will flow through it.

Let I_1 be current through R_1 ; it will also be the current through R_3 , because none flows through the galvanometer, and the same quantity of electricity flows toward B as away from it. Also, let I_2 be the current through the branch ACD . Then, the potential difference between A and B being the same as that between A and C , we have by Ohm's law (219)

$$R_1 I_1 = R_2 I_2 \quad . \quad . \quad . \quad . \quad (a)$$

Similarly, $R_3 I_1 = R_4 I_2 \dots \dots \dots (b)$

Dividing (a) by (b), $\frac{R_1}{R_3} = \frac{R_2}{R_4}$.

This equation may be written

$$\frac{R_1}{R_2} = \frac{R_3}{R_4},$$

or $R_1 : R_2 :: R_3 : R_4$.

When therefore the resistances are so adjusted that no current flows through the galvanometer, the four form a proportion. In practice three of the resistances are fixed, and the adjustment for a balance is made by varying the fourth. It is necessary to know only the ratio R_3 / R_4 , for example; then the equation gives the relation between R_1 and R_2 .

227. Cells joined in Series. — Let there be n similar voltaic cells, each having an electromotive force E and an internal resistance between the terminals of the cell equal to r . Then if R is the external resistance, by Ohm's law

$$I = \frac{E}{R + r}.$$

The n cells may be joined in series by connecting the negative of the first with the positive of the second; the negative of the second with the positive of the third, and so on. Then the total E.M.F. between the positive of the first and the negative of the last will be nE , and the entire internal resistance will be nr . Hence

$$I = \frac{nE}{R + nr}.$$

If R is small in comparison with r , then $I = E/r$ nearly, or

the current is no greater than could be obtained from one cell. But if R is large in comparison with r , or even nr , then the current is nearly n times as great as one cell alone will yield.

228. Graphical Representation of Potentials for Cells in Series. — Let there be three cells in series; and let AB (Fig. 115) represent $3r$, the internal resistance of the three. Also let

BC equal the external resistance R on the same scale. Beginning at A , erect a perpendicular Ab equal to E , the E.M.F. F. of one of the cells. Suppose the E.M.F. to originate at the surface of the zinc.

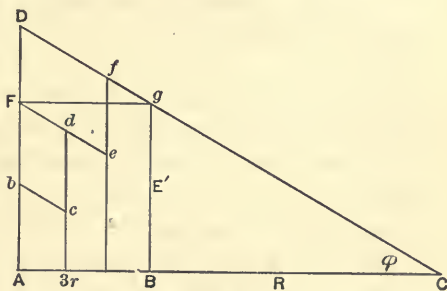

Fig. 115.

Then as the current flows across through the liquids over the resistance r there will be a fall of potential represented by the sloping line bc . At c , the zinc of the second cell, there is a sudden rise of potential cd , equal to Ab , and then a fall from d to e ; at e there is a third rise, represented by ef ; then another drop from f to g over the internal resistance of the last cell. The potential difference between the terminals of the battery is then Bg , and this is the loss of potential over the external resistance R .

The line AD represents $3E$, and DF is the loss of potential in the three cells on account of their internal resistance. Then

$$\tan \phi = \frac{3E}{R + 3r} = \frac{E'}{R} = I.$$

Since the tangent of the angle of slope is the numerical value of the strength of current, it is evident that the lines bc , de , and fg must slope at the same angle as DC , or must be parallel to one another, because the current has the same value in every part of the circuit.

If the external resistance were made infinite by opening the circuit, the line DC would become horizontal, and the current zero. Also, with any given external resistance, the less the internal resistance the less the difference between $3E$ and E' .

229. Cells joined in Parallel. — A battery is said to be connected *in parallel*, or *in multiple*, when all the positive terminals are joined together, and likewise all the negatives. The chief object aimed at is the reduction of the internal resistance. In the case of storage cells, which have a very low resistance, they may be joined in parallel when it is desired to use a larger current than the normal discharge current for one cell. With several cells in parallel, the current through the external circuit is divided among them.

If n similar cells are connected in parallel, the E.M.F. is the same as for a single cell, but there are n internal paths of equal resistance through the cells, and the resultant internal resistance is r/n . Hence

$$I = \frac{E}{R + \frac{r}{n}}$$

In case R is small in comparison with r , the reduction of the internal resistance secured by joining the n cells in parallel results in a larger current, but no such result follows for a large external resistance. For the latter condition the cells should be in series.

230. Cells in Multiple Series. — Let there be m series of n cells each, the m series being joined in parallel. The whole number of cells is then mn . The current will be

$$I = \frac{nE}{R + \frac{nr}{m}} = \frac{E}{\frac{R}{n} + \frac{r}{m}}.$$

To find the condition for a maximum current it may be remarked that the product of the two terms in the denominator of the last expression is Rr/nm , a constant. R and r are assumed to be constant, and nm is the whole number of cells. But when the product of two terms is a constant, their sum is least when they are equal to each other, or when $R/n = r/m$. For this condition

$$R = \frac{nr}{m}.$$

But R is the external resistance and nr/m is the internal resistance. For the greatest steady current, therefore, the cells should be so arranged that the resulting internal resistance shall be equal to the external resistance. The efficiency may then be said to be 50 per cent, since half the energy is wasted internally and half may be utilized externally. This relation does not hold if there is a counter E.M.F. in the circuit.

231. Variation of Internal Resistance with Current. — The internal resistance of a given cell is not a fixed quantity. It changes with the operation of the cell, on account of the chemical changes going on which alter the composition of the liquids. It is also dependent on the current drawn from the cell. The larger the current, the smaller is the measured internal resistance. The

curves of Fig. 116 represent graphically the relation between the internal resistance and the current for two particular cells. The lower curve was made from obser-

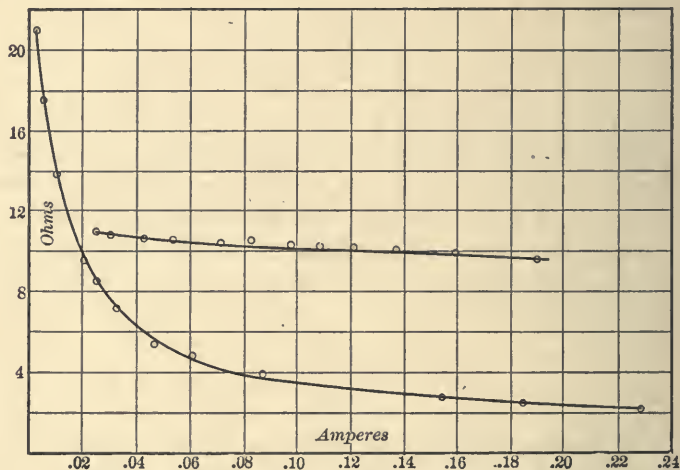

Fig. 116.

vations on an old "dry cell," and the upper one from observations on a Daniell cell. The scale for the internal resistance of the latter is twice as large as for the former. The dry cell showed a most remarkable fall in the resistance as the current increased.

PROBLEMS.

1. Three Daniell cells are connected in series; the E.M.F. of each cell is 1.1 volts and the internal resistance 2 ohms; if the external resistance is 5 ohms, find the current.

2. Two Leclanché cells are joined in parallel; each has an E.M.F. of 1.5 volts and an internal resistance of 4 ohms. If the external resistance consists of two parallel conductors of 2 and 3 ohms respectively, find the current through each branch.

3. Deduce the formula for the resistance of three conductors in parallel.

4. Three Bunsen cells are connected in series with one another and with one copper oxide cell, the latter with its poles set the wrong way round. If the internal resistance of the Bunsens is 0.5 ohm each and that of the other cell 0.2, find the current through an external resistance of 3 ohms (201).

5. Two equal masses of copper are drawn into wire, one 10 metres long and the other 15 metres. If the resistance of the shorter piece is 0.4 ohm, find that of the longer.

6. Three wires are joined in parallel; their resistances are 30, 20, and 60 ohms. Find the resultant resistance.

7. The resistance between two points A and B of a circuit is 25 ohms; on joining another wire in parallel between A and B the resistance becomes 20 ohms. Find the resistance of the second wire.

8. The terminals of a battery of five Grove cells in series, the total E.M.F. of which is 9.5 volts, are connected by three wires, each of 12 ohms resistance. If the current through each wire is one-third of an ampere, find the internal resistance of each cell.

9. Given 24 cells, each of 1 volt E.M.F. and 0.5 ohm internal resistance. How should they be connected to give a maximum current through an external resistance of 3 ohms? What will be the current?

10. What is the resistance of a column of mercury 212.6 cms. long and 0.5 of a square millimetre in cross-section, at a temperature of 25° C.? Temperature coefficient of mercury, 0.072 per cent per degree C.

CHAPTER XIX.

THERMAL RELATIONS.

232. **Conversion of Electric Energy into Heat.**— Electric energy is readily convertible into other forms. If an electric current encounters a back E.M.F. anywhere in the circuit, work will be done by the passage of the current against this opposing E.M.F. Such is the case in electrolysis and in the storage battery. All the energy of an electric current not so converted, or stored up in some form of stress, is dissipated as heat. Heat appears wherever the circuit offers resistance to the current. In a simple circuit containing no devices for transforming and storing energy, all of it is frittered away as heat. Part of it disappears in heating the battery or other generator, and the remainder in heating the external circuit.

The heat evolved by dissolving 33 gms. of zinc in sulphuric acid Favre found to be 18,682 calories. When the same weight of zinc was consumed in a Smee cell, the heat evolved in the entire circuit was 18,674 calories. These operations were conducted by introducing the vessel containing the zinc and acid in the first case, and the Smee cell and its circuit in the second case, into a large calorimeter. The two quantities are nearly identical, or the heat evolved is the same whether the solution of the zinc produces a current or not. When the electric current was employed to do work in lifting a weight, the heat generated in the circuit was diminished by the exact thermal equivalent of

the work done. When, therefore, a definite amount of chemical action takes place in a battery and no work is done, the distribution of the heat is altered, but not its amount.

233. Laws of the Development of Heat. — The laws of the development of heat in an electric circuit were discovered experimentally by Joule and Lenz. The latter experimented with a simple calorimeter represented in Fig. 117. A thin platinum wire, joined to two stout conductors, was enclosed in a wide-mouthed bottle containing alcohol. A thermometer t was passed through a hole in the insulating stopper of the bottle. The resistance of the fine wire was known, and the observations consisted in measuring the current and noting the rise of temperature. Joule found that the number of units of heat generated in a conductor is proportional —

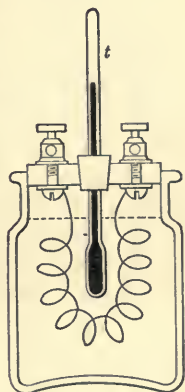

Fig. 117.

- (1) To its *resistance*.
- (2) To the *square* of the strength of the current.
- (3) To the *length of time* the current flows.

234. The Heat Equivalent of a Current. — Let the potentials of two points A and B of a conductor be V_1 and V_2 ; and let Q units of electricity be transferred from A to B in the time t . Then the work done, expressed in ergs, will be

$$W = Q(V_1 - V_2).$$

If all this work is converted into heat, $W = JH$, by (86); if the current of strength I flows for time t , the quantity

$Q = It$, since the strength of current is the quantity passing any section of the conductor in one second; also $V_1 - V_2 = RI$. Substituting,

$$JH = I^2Rt,$$

and

$$H = \frac{I^2Rt}{J} = \frac{I^2Rt}{4.19 \times 10^7}.$$

The current strength and the resistance are expressed in C.G.S. electromagnetic units (294). An ampere is 10^{-1} C.G.S. unit; an ohm, 10^9 . If the measurements are made in amperes and ohms, then for I^2 must be substituted $I^2 \times 10^{-2}$, and for R , $R \times 10^9$. The equation then becomes

$$H = \frac{I^2R \times 10^7}{4.19 \times 10^7} t = I^2Rt \times 0.24.$$

The energy expended per second is the product of the current strength and the electromotive force. If I be measured in amperes and E in volts (a volt is 10^8 C.G.S. units), then

$$W = IE \times 10^{-1} \times 10^8 = IE \times 10^7 \text{ ergs per second,}$$

or IE watts (I., 43). But

$$H = I^2R \times 0.24 = IE \times 0.24 \text{ calories per second.}$$

Therefore one watt is equivalent to 0.24 calorie per second.

235. Counter E.M.F. in a Circuit. — The total activity, or rate at which a generator is supplying energy to the circuit, is represented in part by the heat evolved in accordance with Joule's law and in part by work done, such as chemical decomposition by electrolysis, the mechanical work of a motor, etc. In every case of doing work the energy absorbed is proportional to the current strength instead of its square. We may therefore write for the whole energy transformed in time t

$$IEt = I^2Rt + AIt.$$

The first term of the second member of this equation is the waste in heat; the second, the work done; A is a constant. Dividing through by It and transposing,

$$I = \frac{E - A}{R}.$$

R is the entire resistance of the circuit. It is evident from the form of the equation that the quantity A is of the nature of an E.M.F. Since it is affected by the negative sign it is a counter E.M.F. The effective E.M.F. producing the current is the applied E.M.F. less the back E.M.F. This counter E.M.F. is a necessary phenomenon in every case in which work is done by an electric current.

236. Division of the Energy in a Circuit. — If the counter E.M.F. be represented by E' , the equation for the current by Ohm's law is

$$I = \frac{E - E'}{R}.$$

But the heat waste in watts is

$$I^2 R = I(E - E') = IE - IE'.$$

Now IE is the total activity in the portion of the circuit considered. The heat generated in this same portion of the circuit of resistance R is less than the entire activity by IE' watts. Hence the energy spent per second in doing work is the product of the current strength and the counter E.M.F.

The ratio of the work done to the heat waste is

$$\frac{IE'}{I(E - E')} = \frac{E'}{E - E'}.$$

The efficiency with which electric energy is converted into work increases therefore with the counter E.M.F.

237. Applications of the Heating Effect of a Current.

—Of the various applications of heating, the following are some of the more important:

1. *Electric Cautery.* A thin platinum wire heated to incandescence is sometimes employed in surgery instead of a knife. Platinum is used because it is infusible, except at a high temperature, and is not corrosive.

2. *Safety Fuses.* Advantage is taken of the low temperature of fusion of some alloys, in which lead is a large constituent, for the purpose of automatically interrupting the circuit when for any reason the current becomes excessive. Some of these alloys, notably those containing zinc, may oxidize on heating; and if the current be increased slowly the fused metal may become encased in the oxide as an envelope, and be heated to redness without breaking the circuit. Safety fuses should be mounted on non-combustible bases; their length should be proportioned to the voltage employed on the circuit in which they are placed. Provision is sometimes made for an automatic blast, produced by the explosive vaporization of the metal, to blow out the arc which is formed between the terminals when the fuse "blows."

3. *Electric Heating.* Electric street-cars are sometimes heated by a current through suitable iron-wire resistance embedded in cement, asbestos, or enamel. Similar devices for cooking have now become articles of commerce. Small furnaces for fusing, vulcanizing, and enameling in the operations of dentistry are also in use. For such purposes electric heating offers a wide field of application.

4. *Electric Welding.* If the abutting ends of two rods are pressed together while a large current passes through them, enough heat is generated at the junction where the

resistance is greatest to soften and weld them. This method has been perfected by Elihu Thomson, who employs several hundred amperes in some cases, but under a low electric pressure. Fig. 118 shows three small welded joints.

Similar devices are now employed for the local annealing of armor plates; the metal is in this way softened at points where it is to be drilled.

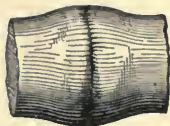

Fig. 118.

238. **The Electric Arc.**—In 1800 Sir Humphrey Davy discovered that if two pieces of charcoal, connected by suitable conducting wires to a powerful voltaic battery, be brought into contact and be then separated a slight distance, brilliant sparks will pass between them. But no mention was made of the electric arc till 1808. In 1810 Davy exhibited the arc light at the Royal Institution.

With a battery of 2,000 simple elements, when the carbons were drawn apart to a distance of several inches, the carbon was apparently volatilized, and the current was conducted across in the form of a curved flame or *arc*. A brilliant light was emitted at the same time by the white-hot carbon electrodes, which rapidly burned away, unless they were enclosed in a vacuum. Foucault surmounted this difficulty in 1844 by making use of the dense carbon from a gas retort in place of the wood charcoal pencils.

When the carbon points are separated the heat due to the current volatilizes some of the carbon, or the volatile constituents not expelled by previous baking, and this

carbon vapor conducts the current across. The passage of the current heats the carbons to vivid incandescence. Since gases are poor radiators, the dazzling light is emitted chiefly by the carbon electrodes and especially by the positive one. In it is formed a small cavity by the transport of carbon across to the negative. According to Violle, the temperature of this cup-shaped depression, or *crater*, is about $3,500^{\circ}$ C. It is the temperature at which carbon volatilizes. The positive carbon wastes away about twice

as fast as the negative. The appearance of the two carbon pencils is shown in Fig. 119.



Fig. 119.

The resistance of the electric arc may be only a fraction of an ohm. It is not large enough to account for all the heat developed; but the crater in the positive appears to be the seat of a counter E.M.F. of about 39 volts for a quiet arc. Hence a potential difference of from 40 to 45 volts is necessary to maintain a steady arc without hissing.

The large quantity of heat generated is due to the fact that the current encounters an opposing E.M.F. at the arc, and energy is in consequence transformed into heat.

239. The Carbon Filament.—In the incandescent system of electric lighting the heat is due to the simple resistance of a thin carbon filament. Carbon is the only substance thus far found to be available, because it does not fuse and has a high radiating power.

The filament is made of a variety of materials, including certain vegetable fibres, silk, and parchmented cotton thread. After preliminary treatment it is carbonized by raising to a cherry-red heat out of contact with the air. It is then surrounded by an atmosphere of rarefied hydrocarbon vapor, and is raised to a white heat by a current. The heat decomposes the vapor, and the carbon residue is deposited in a dense form on the filament. By this treatment it acquires a hard, steel-gray surface and greater uniformity. Its durability is thereby greatly increased.

The filament is finally mounted in an exhausted glass globe and provided with convenient external terminals. The vacuum prevents oxidation and loss of energy by heat convection.

The temperature to which the carbon filament can be raised is limited by volatilization, and by a tendency of the carbon to disintegrate at high temperatures. This disintegration rapidly reduces the thickness of the filament and blackens the glass bulb.

A 100-volt, 16-candle-power lamp has a resistance hot of about 200 ohms. The current is then half an ampere, and each lamp transforms into heat 50 watts, or three and one-eighth watts per candle. A 50-volt lamp of the same candle power has only one-quarter of the resistance and takes double the current for the same candle power.

240. Thermal Electricity. — When heat is applied to the junction of two dissimilar substances an E.M.F. is produced, which will cause a current to flow across the junction from the substance of lower potential to the one of higher if there is a closed circuit. This phenomenon is the converse of the generation of heat by a current. It was discovered by Seebeck in 1821 or 1822. If a circuit be

formed of an iron and a copper wire, and if the temperature of one of the junctions be raised above that of the other, a current will flow across the warmer junction from copper to iron.

The heated junction is the seat of an E.M.F. of such direction that the iron is at a higher potential than the copper. A current therefore flows around through the circuit from the warmer iron across the cooler junction and back to the warmer copper. Across the warmer junction the current flows from lower to higher potential.

The dissimilar substances composing a thermo-electric pair may be either two metals, a metal and a liquid, two liquids, or even two pieces of the same metal at different temperatures or in different physical states.

241. Neutral Temperature. — The E.M.F. of a thermal element is small, and depends not only on the temperature-difference of the two contacts, but on the absolute values of their temperatures. Every combination of two metals appears to have what is called a *neutral temperature*. It is the mean of the temperatures of the two junctions when the electromotive forces at the two are equal and in opposite directions round the circuit. For this neutral temperature there is therefore no current. For silver and iron the neutral temperature is $223^{\circ}.5$ C.; for copper and iron it is $274^{\circ}.5$ C. When the mean temperature is above the neutral temperature for the two substances, the current is reversed. If t_1 and t_2 are the temperatures of the two junctions, there is no current when t_1 equals t_2 , and none when $\frac{1}{2}(t_1 + t_2)$ equals the neutral temperature.

If an iron and a copper wire be twisted together and their free ends connected to a galvanometer, moderate heating of the twisted junction will cause a current to flow

across it from copper to iron ; but if the junction be heated to a dull red, the galvanometer will indicate a reversal of the current.

242. Variation of Thermal Electromotive Force with Temperature. — If one junction of a thermal couple, such as iron and copper, be kept at a fixed temperature, while that of the other is gradually raised, the E.M.F. increases to a maximum, then diminishes.

at length vanishes, and is finally reversed. With most pairs of metals, if the temperatures be plotted as abscissas and the electromotive forces as ordinates, the result will be a parabola with its axis vertical (Fig. 120). If, therefore, e denotes the E.M.F. and t the temperature, and if E and T denote

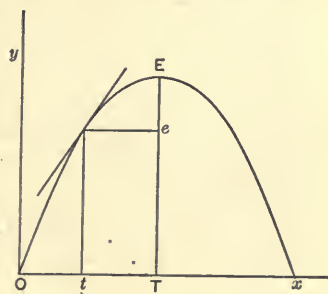

Fig. 120.

the E.M.F. and temperature corresponding to the vertex of the parabola, we obtain

$$E - e = b (T - t)^2,$$

where b is a constant. This equation expresses the property of a parabola that the square of the distance of any point from the axis is proportional to the distance of the same point from the tangent through the vertex. The curve in the figure is drawn for the case where the temperature of the one junction is zero. If it be above zero, the parabola corresponding will have the same axis as this one, but will lie below it. The temperature corresponding to the maximum ordinate will be the same. It is the neutral point for the given pair of metals.

In particular cases the curve is a straight line ; in others

it is made up of parts of parabolas, with their axes parallel, but with their vertices turned alternately in opposite directions (Peddie).

243. Thermo-electric Diagram. — The relation between E.M.F. and temperature just described led Lord Kelvin and Professor Tait to adopt an elegant method of constructing a *thermo-electric diagram*. The *thermo-*

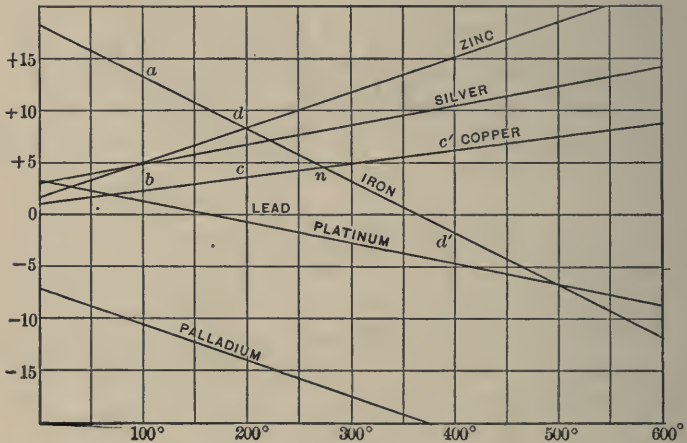

Fig. 121.

electric power of any couple is the E.M.F. corresponding to a temperature difference of one degree between the two junctions. It is, in other words, the rate of variation of the E.M.F. with temperature. By a simple application of the Differential Calculus to the equation of the last article, we obtain for this rate of variation,

$$\frac{de}{dt} = 2b(T-t).$$

This expression represents the thermo-electric power, and it is the equation of a straight line. If then this line for

some standard metal be made to coincide with the axis of temperature, the lines obtained from observations on couples of other metals with it will in general be straight lines; taken together, these lines form a thermo-electric diagram.

The point of intersection of any pair of lines corresponds with the temperature of maximum E.M.F. for this pair of metals. Thus the copper-iron lines cross at $274^{\circ}.5$; this is therefore the temperature at which the thermo-electric power of these metals becomes zero. It is also the neutral temperature for the pair. Fig. 121 is the thermo-electric diagram for several metals compared with lead. The intersections of some of these lines lie beyond the limits of Tait's experimental diagram. The palladium-copper lines if produced would meet at -170° C. Dewar and Fleming have found, by means of the low temperature obtained by liquid oxygen, that thermo-electric inversion for this pair does occur at about -170° .

244. Electromotive Force in the Thermo-electric Diagram.—From the manner in which a thermo-electric diagram is constructed, it follows that the E.M.F. between any pair of metals between two temperatures is equal to the area of the figure included between the ordinates corresponding to those temperatures and the thermo-electric lines of the metals. Thus, if the cooler junction of a copper-iron couple be at 100° and the warmer at 200° , the effective E.M.F. in the circuit will be represented by the area $abcd$; but if the warmer junction be at 400° , the E.M.F. will be equal to the difference of the areas abn and $c'd'n$. If the triangle above the intersection n be larger than the one below n , the E.M.F. will be reversed.

The ordinates represent thermo-electric powers. But

$$de/dt = \text{Thermo-electric power,}$$

and therefore $de = \text{Thermo-electric power} \times dt.$

Now de is the small E.M.F. corresponding to a small temperature difference dt , and the second member of the last equation is a small area whose length is a line ab and whose width is an element of temperature measured at right angles to ab . The E.M.F. for any finite temperature-difference is therefore an area such as $abcd$, which is made up of a number of small areas corresponding to minute temperature-differences.

245. Thermo-electric Series. — A thermo-electric series is a table of metals showing their thermo-electric relation to one another. Since the thermo-electric power depends on the absolute temperature of the junctions, such a list is good only for some definite mean temperature. The following series gives the E.M.F. in microvolts (millionths of a volt) between each metal and lead, with a difference of one degree between the junctions when their mean temperature is 20° C.:

Bismuth	-89	Silver	+ 3.0
Cobalt	-22	Zinc	+ 3.7
German silver	-11.75	Copper	+ 3.8
Mercury	- 0.418	Iron	+ 17.5
Lead	0.0	Antimony, axial	+ 22.6
Tin	+ 0.1	Antimony, equatorial	+ 26.4
Platinum	+ 0.9	Tellurium	+ 502
Gold	+ 1.2	Selenium	+ 807

When a junction of any pair of these metals is moderately heated, the current flows across it from the metal standing higher in the list toward the one standing lower. For the smaller values of the thermo-electric powers, the results obtained by different observers are not very concordant.

246. The Thermopile. — The E.M.F. of a single thermal element is very small; to get a larger E.M.F. a

number of similar couples may be joined in series. With n such couples in series the potential difference between the extreme terminals is n times that of a single couple, and the internal resistance of the series is still very low. Fig. 122 shows the method of connecting in series. If the bars A are antimony and B bismuth, then heating the junctions c, c, c , will cause a current to flow through the circuit in the direction of the arrow; but if these junctions be cooled, or the alternate ones d, d , be heated, the current will circulate in the other direction.

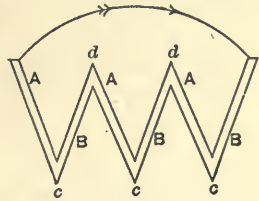

Fig. 122.

When a number of bars of antimony and bismuth are soldered together in this way, and packed together in the form of a cube, with insulating material between adjacent bars, so that opposite faces of the cube form alternate junctions, the instrument is called a *thermopile* (Fig. 123). If a face of such a pile be blackened with lamp-black and be provided with a reflecting cone, the instrument becomes a sensitive detector of radiant heat (69).

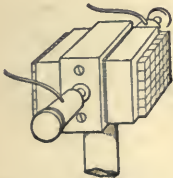

Fig. 123.

247. The Peltier Effect. — In 1834 Peltier discovered the phenomenon which bears his name; it is an extension of the discovery of Seebeck. If a bismuth-antimony junction be heated, the current flows across from the former to the latter. Peltier discovered that if a current from an external E.M.F. be sent through such a compound bar from bismuth B to antimony A (Fig. 124), the junction will be cooled; but if it be sent the other way, the junction will be heated.

The long arrow shows the direction of the current sent through; the small arrows at a and b indicate the direction of the E.M.F. at the junctions. At a the thermal E.M.F. is in the direction in which the current is flowing. Hence

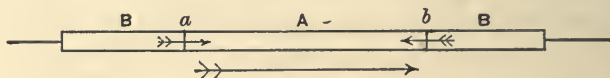

Fig. 124.

at this junction work is done on the current, and the heat of the metals is converted into the energy of the current. At b the thermal E.M.F. opposes the current, which therefore does work on the junction and heats it.

The thermal effect at a junction of dissimilar substances differs greatly from the thermal effect due to simple resistance. The Peltier effect is *reversible*, the current heating or cooling the junction according to its direction, while the quantity of heat evolved or absorbed varies simply as the current; the heat due to resistance is independent of the direction of the current, and is proportional to the square of its strength.

248. Experiment to show the Peltier Effect. —

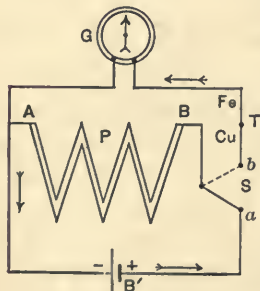

Fig. 125.

Connect one or two Leclanché cells with a thermopile, as in Fig. 125. S is a two-point switch. When it is turned in the direction of the full line, the battery circuit through the thermopile is closed and the galvanometer circuit is open. When it stands in the direction of the dotted line, the battery is cut off and the thermopile is connected with the

galvanometer. In order to show that the current given by the thermopile P is opposite in direction to the current through it from the battery, insert in the circuit of the galvanometer at T a copper-iron junction. With the switch at b , the current produced by heating this junction flows from Cu to Fe , and the direction of the galvanometer deflection may be noted. Turn the switch for a moment to a and then back again to b . The galvanometer will show a current coming from the thermopile, and the direction of the deflection will be the same as when the junction T was warmed. Hence B must be the positive and A the negative of the thermopile as a generator. But the current from the battery enters the pile at B and leaves it at A . The thermal effects produced by the current through the pile are such as to generate a counter E.M.F.

249. The Thomson Effect. — For the purpose of explaining electric inversion in such couples as iron and copper, Lord Kelvin assumed that the Peltier effect becomes zero at the neutral temperature. No heat is then absorbed or evolved at a junction at this temperature, but heat is generated at the other junction, since the current there meets a counter E.M.F. If in Fig. 126 the junction J is at the neutral temperature T , and J' at a lower temperature t , the current will flow in the direction of the arrows. At J' , therefore, it flows from Fe to Cu , and heat is generated by the Peltier effect. There is then no conversion of thermal into electrical energy at the junctions; but since there is no other possible source of the energy of the current except heat, Lord Kelvin was led to predict that heat is absorbed

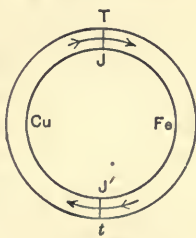

Fig. 126.

at parts of the circuit other than the junctions. This prediction he subsequently verified by experiment.

In copper heat is absorbed when the current passes from cold parts to hot parts; in iron it is absorbed when the current passes from hot parts to cold parts. This phenomenon is called the *Thomson Effect*, or the Electric Convection of Heat.

Consider a metallic bar ABC (Fig. 127) heated at the middle B and cooled at the ends A and C . Then the distribution of heat may be represented by the curve abc . But if a current be passed from A to C , then in metals like copper the curve of the distribution of heat becomes somewhat like $a'bc'$.

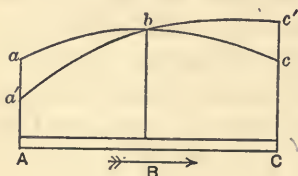

Fig. 127.

Since a current in copper absorbs heat as a liquid does in flowing

from the cold to the hot parts of a tube, electricity is sometimes said to have specific heat. It is positive in metals like copper and negative in metals like iron. In lead the Thomson effect is nearly or quite zero; it is for this reason that lead is chosen as the zero line of the thermo-electric diagram.

250. Thermo-electromotive Force between Metals and Liquids. — The thermo-electromotive forces originating at metal-liquid contacts have special interest because of their relation to the temperature coefficient of voltaic cells. These electromotive forces are larger than most of those between metals. Thus, the thermo-electric power of $Zn-ZnSO$ is 0.00076 volt for a mean temperature of $18.5\text{ }^\circ\text{C}$.; that of $Cu-CuSO$ is 0.00069 volt for about the same temperature. In microvolts these are 760 and 690

respectively. Since the metal is positive to the liquid in both cases, and there is no appreciable E.M.F. at the contact of the two liquids, the temperature coefficient of a Daniell cell is the difference of the above two thermo-electric powers, or 0.00007 volt per degree C. It is, moreover, negative because the thermal E.M.F. on the zinc side is greater than on the copper side. This conclusion has been fully verified by experiment.

The author has applied the same method of analysis to other cells, such as the Clark without zinc-sulphate crystals, and the calomel cell; the results with all of them show that the temperature coefficient is determined by the superposition of the several thermal electromotive forces at the contacts of the dissimilar substances in the cell, whenever this coefficient is not complicated by the solution and recrystallization of salts. Whether the resultant temperature coefficient shall be positive or negative depends on the relative values and signs of the thermal electromotive forces on the two sides of the cell.

PROBLEMS.

1. The poles of a voltaic cell are joined by two wires in parallel alike in every respect, except that one is twice as long as the other. What are the relative quantities of heat generated in the two?

2. The E.M.F. of a battery is 20 volts and its internal resistance 2 ohms. The potential difference between its poles when connected by a wire *A* is 16 volts; it falls to 14 volts when *A* is replaced by another wire *B*. Calculate the number of calories of heat generated in the external circuit in 3 min. in the two cases.

3. A current of 10 amperes passes through a resistance of 2 ohms for 14 sec. Find the number of calories of heat generated.

4. The resistances of two wires are as 3 to 4. Find the relative quantities of heat produced in the same time, — (1) when they are joined in series, (2) when connected in parallel between the poles of a voltaic cell.

5. A battery has an E.M.F. of 8.5 volts; the total resistance in the circuit is 20 ohms, including an electrolytic cell. The heat generated per second in a 5.12-ohm coil included in the circuit is 0.12 calorie. What is the counter E.M.F. of the electrolytic cell?

6. If one junction of an antimony-bismuth pair be at 20° and the other at 65° C., what will be the E.M.F.?

7. A ring is made partly of copper and partly of iron wire. Compare the E.M.F. if one junction be kept at 0° and the other at 100° C. with the E.M.F. obtained by keeping one junction at 175° and the other at 275° C.

CHAPTER XX.

PROPERTIES OF MAGNETS.

251. **Relation to Electricity.** — The most important properties of an electric circuit are its magnetic relations. Magnetism is more readily and conveniently evoked by electric currents than by any other means. In fact, von Siemens said that “the electric current, or generally electricity in motion, is the only known source of all magnetism.” But the magnetic properties of an electric current must be studied by means of magnets; it is, therefore, necessary that some preliminary study of the properties of a magnet should precede the study of the magnetic relations and effects of electric currents.

252. **Fundamental Phenomena.** — Black oxide of iron, known as magnetite, is widely distributed, and is sometimes found to possess the property of attracting iron. If a piece of it be suspended by an untwisted thread (Fig. 128) its longer dimension will point not far from north and south. Such bodies are called *magnets*. The property of orientation has been utilized in navigation for several centuries, and from this fact the magnet in early times acquired the name of *lodestone*, or leading stone.



Fig. 128.

253. **Artificial Magnets.** — If a piece of hard iron or steel be stroked with a lodestone it will acquire the same magnetic properties; fine iron filings will cling to it, and if suspended it will point north and south. The end which points northward is called the *north-seeking pole* and the

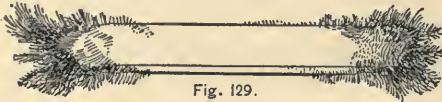

Fig. 129.

other end the *south-seeking pole*; the magnet is said to possess *polarity*. If

a bar magnet be dipped into iron filings they will cling to it in tufts near the ends (Fig. 129), but there will be few or none near the middle. This region is called the *equator*. If a long thin rod be magnetized longitudinally the ends act as centres of force or poles, and the imaginary line joining these poles is the *magnetic axis*. The remainder of the magnet is apparently nearly devoid of magnetic properties. In short thick magnets the poles are less definitely defined.

A thin pointed bar of magnetized steel, provided with a cap having hard steel or agate set in it, so that it may turn freely on a sharp steel point around a vertical axis, is called a *magnetic needle* (Fig. 130).

254. **First Law of Magnetic Force.** — If the S-seeking pole of a bar magnet be presented to the N-seeking pole of a magnetic needle (Fig. 130), they will mutually attract each other; but if the N-seeking pole be brought near the same pole of the needle, repulsion will be observed. The law of attraction and repul-

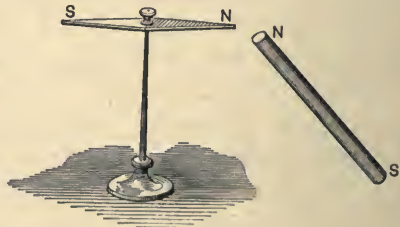

Fig. 130.

sion is accordingly formulated as follows: *Like magnetic poles repel and unlike poles attract each other.*

255. Magnetic Substances. — A magnetic substance is one capable of being affected by a magnet. A piece of soft iron will attract either pole of a magnetic needle, but it does not itself retain the property of attracting other masses of iron, and does not possess the power of orientation when freely suspended horizontally. It has no fixed poles and no equator.

Other substances attracted by a magnet are nickel, cobalt, manganese, chromium, and cerium. Only nickel and cobalt show decided magnetic properties comparable with iron. Some gases are feebly magnetic, and liquid oxygen exhibits conspicuous magnetic properties.

Another class of substances are apparently repelled by a magnet. These are called *diamagnetic* to distinguish them from *paramagnetic* bodies like iron and nickel. Among them are bismuth, antimony, tin, copper, and some others in a less marked degree. Paramagnetic bodies are often designated simply by the word "magnetic."

256. Magnetic Induction. — When a magnet attracts a piece of soft iron, the iron first becomes a temporary magnet by *induction*. Magnetic induction is analogous to electrostatic induction, and takes place along lines of induction or lines of magnetic force. When one piece of iron has been attached to the pole of a magnet, it may in turn act inductively on a second one, and so on in a series of temporary magnets of decreasing strength (Fig. 131).



Fig. 131.

But if the magnet be detached from the first piece and be slowly withdrawn, all the small iron cylinders will fall apart, and they will not again attract one another till they are once more brought under the inductive influence of a magnet. A bar of iron near a magnet is attracted because it becomes a temporary magnet by induction, with the pole nearest to the pole of the inducing magnet of the opposite kind or sign (Fig. 132). Induction thus precedes attraction.

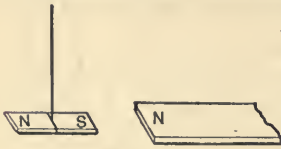

Fig. 132.

257. Permanent and Temporary Magnets. — Permanent and temporary magnets differ only in degree. The softest iron retains a small amount of magnetism after it has been brought under the action of a magnetizing force, while hardened steel retains a large proportion of it. The latter loses some of its magnetism as soon as the magnetizing force is withdrawn, while the former loses the larger part. A much larger magnetizing force is required to magnetize hard steel than soft iron to the same magnetic strength. The relation between the part lost and the part retained depends on the quality and hardness of the iron and on the after treatment which it receives. Cast-iron retains an appreciable fraction of the magnetism induced in it, and this property is utilized in starting the excitation of dynamo machines. The property of resisting magnetization or demagnetization is called *retentivity*. The retentivity of hardened steel is much greater than that of soft iron.

258. Magnetic Field. — Magnetic induction, like electrostatic induction, is exerted through the agency of the

surrounding medium. Evidence in support of this assertion will accumulate as we advance in the study of the subject. It would be unphilosophical to imagine an independent medium or ether for every kind of action propagated through space; it is therefore assumed that the ether concerned in magnetic induction is the same as that essential to the phenomena of light and electrostatics. The ether about a magnet is under magnetic stress, since the space there is traversed by magnetic forces. Such a region, in which a magnetic pole tends to move in a definite direction, is a *magnetic field*.

Lines of magnetic force, or magnetic induction, are lines along which a single ideal magnetic pole would tend to move. The positive direction along a line of force is the

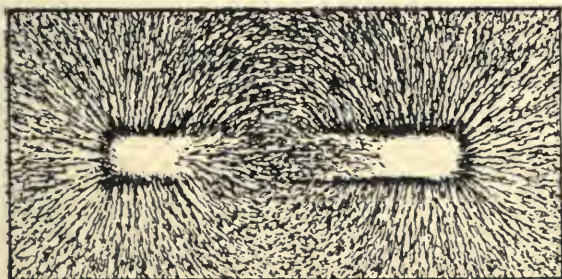

Fig. 133.

direction toward which a free N-seeking pole is urged. If an observer stands with his back to a N-seeking pole, he is looking in the positive direction of the lines of force coming from that pole.

Paramagnetic substances like iron tend to move from the weak to the strong parts of a magnetic field, while diamagnetic substances like bismuth tend to move from the strong to the weak parts of the field.

259. **Magnetic Figures.**—Magnetic figures, or a map of the lines of magnetic force about a magnet, have been known from early times. Fig. 133 shows the forms assumed

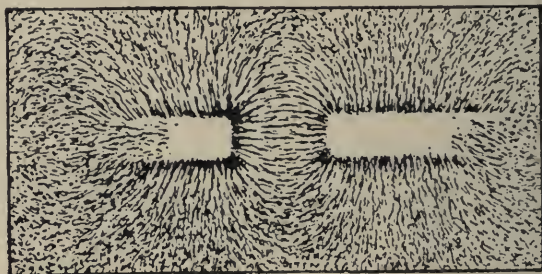

Fig. 134.

by iron filings sifted on a glass plate over a bar magnet. When the plate is gently tapped the filings arrange themselves in curved lines running between the N and S poles. Since the field is symmetrical about the magnetic axis, such a figure may be obtained in any plane passing through the

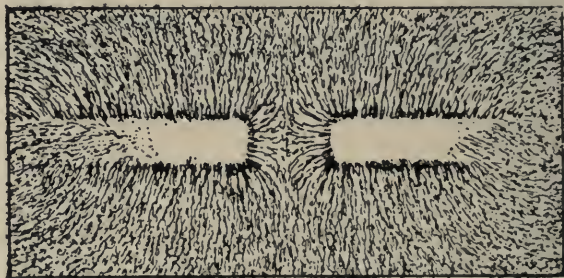

Fig. 135.

axis. Each particle of iron is magnetized by induction and sets itself along a line of force. The whole field about such a magnet is therefore pervaded by lines of force.

They form *closed curves*; through the magnet they run from the S to the N pole, while they complete their circuit in the air from the N around to the S pole.

Fig. 134 was taken from the unlike poles of two similar magnets. The lines of force stretch across from one to the other. Now, lines of force show a tendency to shorten. They act like stretched elastic cords mutually repelling one another. Hence these two poles of opposite sign are drawn together.

Fig. 135 was made from two like poles. No lines extend across from one to the other. Moreover, the elasticity or resiliency of these lines under distortion is plainly such as to force the magnets apart, so that the lines may recover their normal distribution about each pole.

260. **Magnetic Shielding** (J.J.T., 261). — Magnetic attraction and repulsion, and magnetic induction take place through all non-magnetic substances as if nothing were interposed. Suspend a small piece of magnetized watch-spring by a silk fibre inside a glass bottle or a large test-tube. It is affected by external iron or magnets as if the glass were not present. The freedom thus secured from drafts of air makes this a good magnetoscope.

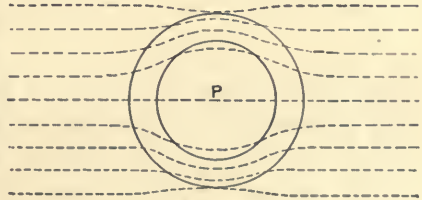

Fig. 136.

Magnetic forces act across all substances, except iron or other magnetic materials if of sufficient thickness. A conductor is a perfect screen from electrostatic action for bodies within it. A magnetic needle in a hollow iron ball is screened in like manner from another system of

magnetic forces, but only imperfectly. Consider a magnetic needle inside an iron shell placed in a uniform magnetic field; that is, a field consisting of a system of parallel equidistant lines of force. When the shell is introduced into this field it is no longer uniform, but the lines pass through the iron in preference to the air. Thus in Fig. 136 let P be the needle within the shell. The lines of force crowd into the iron. They are thus deflected toward the iron within and without. A few will still traverse the hollow space, but the number of these may be made indefinitely small with a sufficient thickness of soft iron. If the inner radius of the shell is one-half the outer, it may easily be that the magnetic force inside is not more than $\frac{1}{200}$ of that outside. The ratio depends on the quality of the iron, or on what may here be called its specific conductivity for lines of force (309).

261. **Consequent Poles.** — A bar of steel may be magnetized in such a way that it will have a succession of poles alternating in sign. Thus in Fig. 137 there are north poles at N , N , and south poles at S , S .

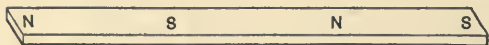

Fig. 137.

The lines of force do not run entirely through the length of the magnet, but the N 's are centres from which they emerge from the magnet and the S 's are centres to which they converge. A consequent pole forms a part of two magnetic circuits. Such poles are often used in dynamo-electric machines.

A ring may be magnetized either so as to present consequent poles, or in such a way that it will exhibit no external magnetic effects. Fig. 138 shows the lines of force about a ring with consequent poles at 1 and 3. In

Fig. 139 there are no poles; that is, there are no points at which the lines of force pass from the iron into the air.

This ring constitutes a closed magnetic circuit, or one in which the lines of force are wholly in the iron. Such a ring has no external magnetic effect, so long as there is no change in its magnetism, because there are no external lines of force.

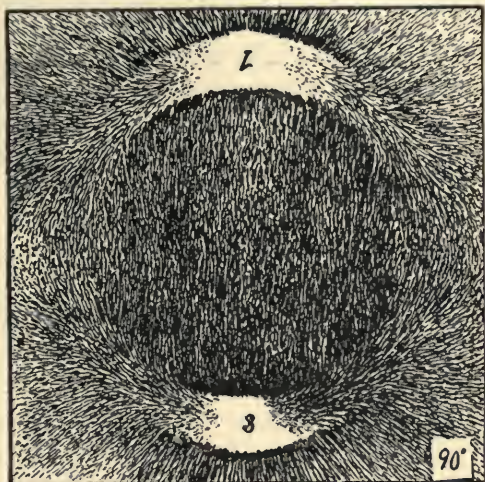

Fig. 138.

Closed magnetic circuits are more retentive of magnetism than open ones.

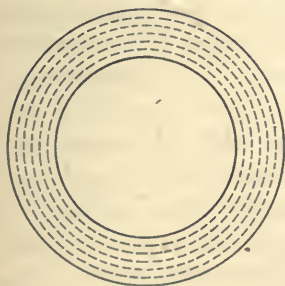

Fig. 139.

262. **Effects of Heat on Magnetism.** — If a permanent magnet be heated to a bright-red heat, all signs of magnetism disappear. Up to 680° C. iron shows but a slight change in its mag-

netic properties; above this a rapid decrease in magnetic susceptibility takes place, so that at about 750° C. it ceases entirely to be magnetic and is quite indifferent toward a magnet. Iron has therefore a magnetic limit, determined

by temperature, and beyond this limit it is not affected by magnetism. Nickel loses its magnetic properties at about 350°C . Chromium ceases to be magnetic at about 500° . The temperature at which magnetic susceptibility reappears when the temperature is reduced is lower than the

critical temperature at which it disappears when the temperature is raised.

Manganese is magnetic only at temperatures near 0°C . According to Dewar, when iron is cooled to about -200°C . in liquid oxygen its susceptibility is twice as great as at 0°C .

The loss of magnetization by heat in the case of nickel is beautifully shown by the simple apparatus of Fig. 140, designed by Bidwell. A thin tongue of nickel is soldered to a copper disk and the whole is blackened and suspended by silk threads. A permanent magnet M is held in such a position that it retains the nickel tongue just over the flame of the alcohol lamp. When

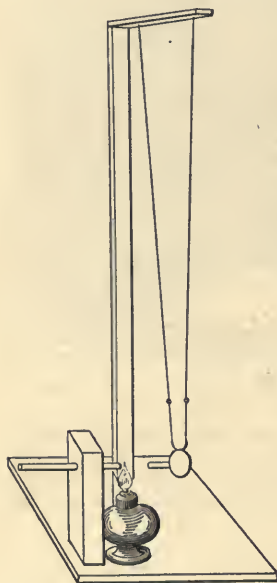

Fig. 140.

the nickel is heated to the proper temperature the magnet releases it and the nickel-copper bob swings as a pendulum. During one or two vibrations it loses sufficient heat by radiation and convection to recover its magnetism; it is then attracted again and held by the magnet. This operation is repeated as soon as the nickel is again heated by the lamp.

263. **Strength of Pole.**—The *strength of pole*, or degree of magnetization, of a magnet is defined by means of its effect on another magnet. Thus, if at the same distance the N pole of magnet A repels the N pole of magnet B with a force f , and magnet C repels B with a force $2f$, then C is said to have twice the strength of pole of A . Strength of pole is denoted by the letter m .

264. **Unit Pole.**—Consider two long, slender, uniformly magnetized needles with their similar poles A and B placed at a distance of one centimetre in air, the other poles being so far away that they exert no appreciable influence in the neighborhood of A and B . Then if A and B are equal poles and the force between them is one dyne, both A and B are poles of unit strength. *A unit pole repels an equal and similar pole at a distance of one centimetre in air with a force of one dyne.* It is necessary to add the qualifying phrase “in air,” because the force would not be one dyne if a magnetic substance intervened.

A pole of strength 2 would repel a unit pole at unit distance with a force of two dynes. Hence if m and m' are the strengths of two poles, the distance between them being unity, the repulsion between the two is mm' dynes. If the poles are of opposite signs mm' is negative, or a negative force means an attraction.

The strength or intensity of a magnetic field at any point is the force exerted on unit pole placed at the point, the introduction of this pole not being supposed to influence the field. Strength of field, or the flux of magnetic force per square centimetre, is conventionally denoted by the number of lines of force passing through one square centimetre at right angles to the direction of the field. It is designated by the letter \mathcal{H} .

Imagine a sphere of unit radius described about a unit pole as a centre. Then the intensity of the field at every point on the surface of this sphere is unity, or one line passes through every square centimetre. Therefore the number of lines belonging to unit pole is 4π , since the surface of the sphere is 4π square centimetres; and for a pole of strength m the number of lines radiating is $4\pi m$.

265. Magnetic Moment.—The moment of a magnet is the product of the strength of its poles and the distance between them, or

$$\mathcal{M} = ml.$$

Let the dotted lines (Fig. 141) be the direction of the field of unit strength, and let ns be a magnet whose strength of pole is m . Then the force on either pole is m and the two forces constitute a couple. The moment of this couple when the magnetic axis of ns is perpendicular to the lines of force of the field is ml , and this is the *magnetic moment*.

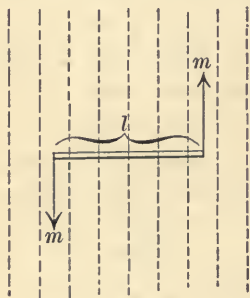

Fig. 141.

266. Intensity of Magnetization.—Intensity of magnetization is the magnetic moment per unit of volume of the magnet. It must be regarded as having not only magnitude but direction, its direction being that of the axis of the magnet. If s is the sectional area of a long uniform rod and l its length, then

$$\mathcal{J} = \frac{ml}{sl} = \frac{m}{s}.$$

Intensity of magnetism is the pole-strength per unit of area.

267. **Second Law of Magnetic Force.** — The first law (254) is qualitative. Coulomb, by means of his torsion balance applied to magnetic poles instead of to electric charges, gave quantitative expression to the law of magnetic force as affected by the distance between the poles :

The force between two magnetic poles is proportional to the product of their strengths and inversely proportional to the square of the distance between them.

This distance must be so great that the poles may be regarded as mere points. Then from the definition of unit pole we may write

$$\mathcal{F} = \pm \frac{mm'}{r^2}.$$

268. **Theory of Magnetic Figures.** — The law of inverse squares can now be applied to elucidate the form of the curves developed about a magnet by means of iron filings. Let NS (Fig. 142) be a long thin magnet, and let P be a N-pointing pole in the field of NS . It will be attracted by S and repelled by N along the lines PS and PN respectively. The forces will be inversely as the squares of these distances, and may be represented by the lines PA and PB . Both forces act on the same pole.

Complete the parallelogram, and the diagonal PC is the resultant force. Since an equal and opposite force acts on the south pole of

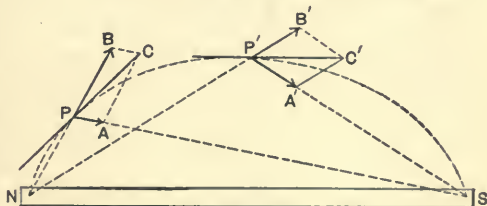

Fig. 142.

the same small magnet represented by a short iron filing, the two forces compose a couple tending to set the particle of iron or other small magnet along the diagonal

of the parallelogram. This line is therefore tangent to the curved line of force passing through P .

If another point P' be chosen, equidistant from N and S , the two forces of attraction and repulsion on either pole at P' are equal and the diagonal is parallel to the axis of NS . Continuing in this way, the direction of the intensity of the field may be found at many points, and the directions combined as tangents to a curve will map out lines of force.

269. Magnetic Forces by Method of Deflections. —

Two methods of making magnetic measurements are worthy of discussion here. In the first a magnetic deflecting force is compared with the intensity of the field in which the magnet is placed by observing the angle of deflection. If a magnetic needle be poised on a sharp point or be suspended by a fine fibre, and if it be deflected by any means from the magnetic meridian, the

forces tending to bring it back constitute a couple; and for equilibrium this couple must be equal to the one producing the deflection.

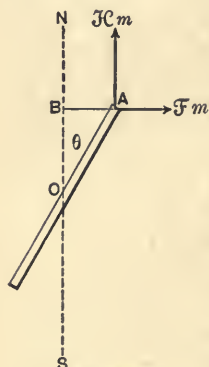

Fig. 143.

Let NS (Fig. 143) be the direction of the magnetic field, and let the magnet be deflected by some force \mathcal{F} at right angles to the field of force. Then the forces acting on the pole of the magnet are $\mathcal{H}m$ in the direction of the field and $\mathcal{F}m$ at right angles to the field. The moment of the first force tending to replace the magnet in the direction of the field is $\mathcal{H}ml \sin \theta$,

where \mathcal{H} is the intensity of the field, m is the strength of pole of the needle, l is the half-length of the needle, and $l \sin \theta$ is the lever arm AB . The moment of $\mathcal{F}m$ is

$\mathcal{F}m \times BO = \mathcal{F}ml \cos \theta$. Equating the two moments and

$$\mathcal{H}ml \sin \theta = \mathcal{F}ml \cos \theta$$

or $\mathcal{F} = \mathcal{H} \tan \theta$.

The magnetic force producing a deflection is equal to the product of the strength of field and the tangent of the angle of deflection.

270. Method of Oscillations. — When a suspended magnetic needle is disturbed from its position of equilibrium it describes a series of oscillations like a pendulum. If the angular deflection be small the vibrations will all be accomplished in the same period. The law of the vibration of such a needle is the same as that of the pendulum (I., 71), since the restoring couple is proportional to the sine of the angle of deflection θ (Fig. 144); and when this angle is small the motion is simple harmonic.

We may therefore write for the period of a complete vibration

$$T = \pi \sqrt{\frac{K}{\mathcal{N}\mathcal{H}}}$$

where K is the moment of inertia of the needle, \mathcal{H} the intensity of the field, and $\mathcal{N}\mathcal{H}$ is the product ml corresponding to Mh in the case of the pendulum.

From this equation

$$\mathcal{N}\mathcal{H} = \frac{\pi^2 K}{T^2} = \pi^2 K n^2, \quad \dots \quad (a)$$

or the intensity of the field is proportional to the square of the vibration-frequency.

The fields at two places may be compared by observing

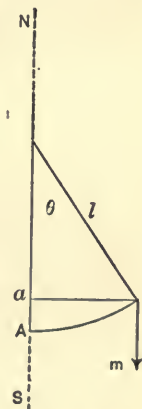

Fig. 144.

the number of vibrations made by the same magnet in equal times, first at the one place and then at the other. Then

$$\frac{\mathcal{H}}{\mathcal{H}'} = \frac{T'^2}{T^2} = \frac{n^2}{n'^2}.$$

271. Comparison of Pole-strengths by Oscillations.

— Let one of the magnets to be compared be placed in the same magnetic meridian with the oscillating needle, and let the field produced by it at the needle be h_1 . Then

$$\mathcal{M} (h_1 + \mathcal{H}) = \pi^2 K n_1^2 = A n_1^2 \dots (b)$$

If the first magnet be replaced by the second one at the same distance from the needle, then

$$\mathcal{M} (h_2 + \mathcal{H}) = A n_2^2 \dots (c)$$

Subtract (a) from (b) and (c) and

$$\mathcal{M} h_1 = A (n_1^2 - n^2),$$

$$\mathcal{M} h_2 = A (n_2^2 - n^2).$$

Whence

$$\frac{h_1}{h_2} = \frac{n_1^2 - n^2}{n_2^2 - n^2}.$$

This equation gives the ratio of the pole-strengths of the two magnets which produce fields h_1 and h_2 at the needle if the distance be constant.

The law of inverse squares can be demonstrated in a similar way by observing the oscillations of a needle first in the earth's field alone, and then in the earth's field plus that of the influencing magnet placed at successive distances from the needle.

272. Magnetization and Mechanical Stress.—

Joule observed that an iron rod increases in length when

magnetized, but that no change of volume takes place. Hence the rod must contract in sectional area. He concluded that if a rod be magnetized circularly, that is, so that the lines of magnetization are circles around the axis of the rod, it should contract in length. This conclusion he verified by experiment.

Bidwell¹ has extended Joule's observations by showing that at a certain magnetization the elongation reaches a maximum, and that for magnetizing forces beyond that the elongation is less and less until the magnet finally remains unaffected; any increase of the magnetizing force beyond this point causes the rod to shorten. Effects of the same kind occur in rings forming closed magnetic circuits; the diameter is increased by small magnetizing forces and is decreased with larger ones.

The mechanical extension of a wire produces increase of magnetization with small magnetizing forces; but Villari found that when the field is sufficiently intense, extension causes a decrease of magnetization. This effect is called the Villari *reversal*. Compression produces the opposite effects to extension.

A circularly magnetized iron wire, when twisted, becomes magnetized longitudinally; and, conversely, torsion in weak fields diminishes longitudinal magnetization and produces circular magnetization. We may therefore conclude that the superposition of both circular and longitudinal magnetizations will cause torsional strain. Wiedemann has demonstrated this to be true in the case of iron. With small magnetizing forces the twist is in one direction, but when the magnetizing forces are large there is a reversal of the direction of the twist. Nickel also exhibits a Villari critical point and reversal for its *residual* magnetism; but

¹ *Proc. Roy. Soc.*, XL., pp. 109, 257.

for large magnetizing forces extension diminishes its magnetization and compression increases it.

273. Magnetism Molecular. — Numerous facts point to the conclusion that magnetism is a molecular phenomenon. If a piece of magnetized watch-spring be broken in two, each half will be a magnet with its poles pointing in the same direction as in the original magnet. Smaller subdivision of the watch-spring simply increases the number of poles without destroying the magnetism. It is therefore inferred that the ultimate particles or molecules of steel and iron are magnets, and that they are naturally and permanently such. If a glass tube be filled with fine iron filings, it may be magnetized; if it be then shaken so as to rearrange the particles, all signs of magnetization disappear. The demagnetization produced by vibrating an iron bar is a phenomenon of similar character. If iron be cast in an intense magnetic field it is found to be strongly magnetized. Beetz deposited iron electrolytically in a thin line on silver parallel to the lines of force in a strong magnetic field. The iron was found to be so highly magnetized that no more permanent magnetism could be induced in it.

Weber's hypothesis is that the molecules of iron and other paramagnetic substances are natural magnets, but in the unmagnetized state of the mass their axes lie in all directions indifferently; when subjected to a magnetizing force the magnetic axes of the molecules turn round more or less in the direction of the axis of magnetization. When they have all been turned in this direction the iron is *saturated* and its magnetization can receive no further increase. As soon as the magnetizing force is withdrawn, the molecules spring back partly toward their former positions; thus, some of the magnetism is temporary, or the

magnet has been supersaturated. In soft iron the molecules offer less resistance to this molecular motion or rearrangement than in steel. Hence hardened steel possesses greater *coercive* force and greater retentivity. To Weber's theory Maxwell made the addition that the magnetized molecules are rotating around their longer axes.

274. Ewing's Theory of Magnetism. — Instead of supposing that in the unmagnetized state the molecular magnetic axes are turned criss-cross, Ewing has shown that the particles are arranged so as to form closed magnetic circuits, or, at least, stable configurations under the action of their mutual forces. A group of such molecules will arrange themselves so as to satisfy their relative attractions and repulsions. To illustrate his theory Ewing constructed a model, consisting of short lozenge-shaped magnets pivoted on points and arranged at equal distances in a horizontal plane. Any small number of these may group themselves in several stable configurations. When they are simply agitated they settle down into groups of equilibrium. With a small external magnetizing force these needles turn through a small angle only; when the force reaches a larger value, some of the needles suddenly turn round and new groupings result, with most of the needles pointing in the direction of the magnetizing force; any further increase of the magnetizing force produces but little effect. These three stages correspond to three similar ones often observed in magnetizing iron (316).

275. The Earth a Magnet. — Since a suspended magnetic needle tends to set itself in a definite direction, it follows that the space about the earth is a magnetic field. A small magnet shows that a couple acts on it to bring its

axis into a definite azimuth, but no force tends to produce motion of translation. This relation is due to the fact that the magnetic pole of the earth is so far distant in comparison with the length of the small magnet that the forces on the two poles of the latter are rigorously equal and in opposite directions. The same condition may be described by saying that the magnetic field due to the earth in the vicinity of the magnet is uniform.

Take a piece of gas-pipe a metre long and carefully freed from magnetism. If it be held horizontally east and west, either end of it will attract both the N-seeking and the S-seeking pole of a magnetic needle. Gradually tilt it into a vertical position. Its lower end will become a N pole and will repel the N pole of the needle. Reverse it and the lower end is again a N pole and the upper end a S pole. Hold it vertically, or, better still, in the meridian and inclined about 75° below the horizontal toward the north, and strike it a sharp blow on the upper end with a hammer. It has now acquired permanent magnetism with the N pole at the lower end. This fact can be demonstrated by holding the pipe horizontally east and west. By reversing it and striking it on the other end the polarity may be reversed, and by graduating the strength of the blow the pipe may be nearly or quite demagnetized.

The earth acts inductively on the pipe, as any other magnet does on a piece of iron, putting it under magnetic stress. The vibration due to the blow gives a certain freedom of motion to the molecules, and they arrange themselves to some slight extent under the influence of the earth's magnetic stress. With the molecules so arranged the pipe becomes a magnet. Bars of iron or steel in a vertical or in a horizontal north-and-south position acquire magnetism by induction from the earth. This is especially

true if they are subjected to frequent jarring. Drills, railway iron, beams, and posts are illustrations.

Since opposite poles attract, it is evident that the northern hemisphere of the earth has the polarity corresponding to the S-seeking pole of a magnet. This south magnetic pole does not correspond with the geographical pole of the northern hemisphere. Sir J. C. Ross, in 1831, found it to be situated in Boothia Felix, just within the Arctic Circle, in latitude $70^{\circ} 5' N.$, and longitude $96^{\circ} 46' W.$ of Greenwich. Schwatke concluded in 1879, from his observations, that the pole had shifted to longitude $99^{\circ} 35' W.$ The magnetic pole in the southern hemisphere has never been reached.

276. Magnetic Declination (B., 682). — The magnetic meridian is the vertical plane coinciding in direction with the earth's field and containing, therefore, the axis of a suspended magnetic needle. This meridian does not in general coincide with the geographical meridian. The angle between the two is called the *magnetic declination*. The declination is east or west according as the N-seeking pole of the needle points to the east or to the west of the geographical meridian. The existence of magnetic declination was not known in Europe till the thirteenth century and was first distinctly delineated on a map in 1436. To Columbus belongs the undisputed discovery that the declination is different at different points of the earth's surface. In 1492 he discovered a place of no declination in the Atlantic Ocean north of the Azores.

Lines connecting points of equal declination are called *isogonic* lines, and the line of no declination is an *agonic* line. According to a chart constructed by the United States Coast and Geodetic Survey, the agonic line in 1890 entered the United States from the Atlantic Ocean at

Charleston, passed in a northwesterly direction through Columbus, Ohio, about centrally through the lower peninsula of Michigan, across Grand Traverse Bay, Lake Michigan, the upper peninsula, and Lake Superior.

The declination on the most easterly border of Maine is now (1896) about 20° W., and on the extreme northwestern boundary of the State of Washington it is 23° E. These values will not change much by the year 1900.

277. Variations in Declination.— The earliest recorded declination is that of London in 1580. It was then $11^{\circ} 18'$ E. In 1657 it was zero at the same place. A westerly declination then set in and attained a maximum value of $24^{\circ} 27'$ W. about 1816; since then it has been slowly diminishing to its present value (1896) of about $16^{\circ} 43'$ W. The needle will again point true north in London about 1976, thus completing a half-cycle of changes in a period of some 320 years.

Similar variations are in progress in other parts of the earth. This change of long period is called the *secular* variation of the declination. Besides it, there are the *diurnal* and *annual* variations. In high latitudes the former may reach 1° , but in middle latitudes it has a mean value of about $7\frac{1}{2}'$. The annual variation is small, and is subject to a periodicity corresponding apparently with the sun-spot period of about eleven years.

Besides these variations, magnetic perturbations occur during earthquakes, volcanic eruptions, and particularly during auroral displays. The perturbations due to this last cause sometimes reach a value as large as one or two degrees. They are felt over wide areas, and are called magnetic storms.

278. **Inclination or Dip.** — If a magnetic needle be carefully balanced on an axis through its centre of gravity before magnetization, its N-seeking pole after magnetization will incline below the horizontal in the northern hemisphere by an angle ranging from 0° to 90° . This angle is called the *inclination* or *dip*. Norman, a London instrument-maker who first measured it in 1576, constructed a *dipping needle*, which is a magnetic needle free to turn about a horizontal axis in a vertical plane, and is provided with a graduated vertical circle. The dip in London in 1576 was $71^\circ 50'$. It undergoes secular changes like those of the declination. The dip in London for 1900 will be $67^\circ 9'$ and in Washington, $70^\circ 18'$. It reached its maximum value in London in 1720 and has since been slowly diminishing. At the magnetic pole in the northern hemisphere the needle points vertically downwards.

279. **Isoclinic Lines.** — Lines connecting points of equal inclination on the earth's surface are *isoclinic* lines. In the vicinity of the equator is a line of no inclination, called the *magnetic equator*. It is a somewhat irregular line and crosses the earth's equator at two points, in longitude near 2° E. and 170° W. It veers as far south as lat. 16° and as far north as lat. 10° . The isoclinic of 72° passes near Princeton, Pittsburgh, Fort Wayne, Michigan City, Iowa City, Helena, and Vancouver Island on the Pacific coast.

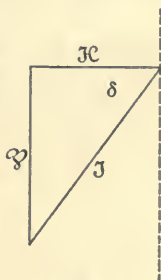

Fig. 145.

280. **Relations between Declination, Inclination, and Total Intensity.** — If δ denotes the angle of dip, then the total intensity of terrestrial mag-

netism may be resolved into a vertical and a horizontal component (Fig. 145) as follows:

$$\mathcal{V} = \mathcal{I} \sin \delta,$$

$$\mathcal{H} = \mathcal{I} \cos \delta.$$

Hence
$$\tan \delta = \frac{\mathcal{V}}{\mathcal{H}}.$$

Lines connecting places where the horizontal component of terrestrial magnetic intensity is the same are called *isodynamic* lines.

PROBLEMS.

1. A magnet whose strength of pole is 150 is placed in a magnetic field whose intensity is 0.18. What forces act on its poles?

2. A bar magnet, $10 \times 2 \times 0.25$ cms., was magnetized to a strength of pole of 50. What was the intensity of magnetization?

3. The horizontal component of the earth's magnetism at station *A* was found to be 0.183; a magnet was oscillated at station *A* and station *B*, and made 60 oscillations in 11 m. 24 s. at the former and in 12 m. 12 s. at the latter. Find the horizontal intensity at *B*.

4. A rectangular magnet, whose length was 15 cms. and strength of pole 50, was set oscillating in a field whose horizontal intensity was 0.18. It made 80 complete vibrations in 15 m. 4 s. Find its moment of inertia.

5. When the magnet of problem 4 was made to oscillate at equal distances from two magnets *A* and *B* successively, it made 80 complete vibrations in 9 m. 4 s. and 10 m. 40 s. respectively. Compare the strength of pole of *A* and *B*.

CHAPTER XXI.

MAGNETIC RELATIONS OF A CURRENT.

281. **Oersted's Discovery.** — The discovery by Oersted at Copenhagen in 1819 was one of prime importance. He observed that when a magnetic needle is brought near a long straight wire conveying a current, the needle tends to set itself at right angles both to the wire and to a perpendicular drawn to it from the centre of the needle; also that the direction in which the needle turns depends on the

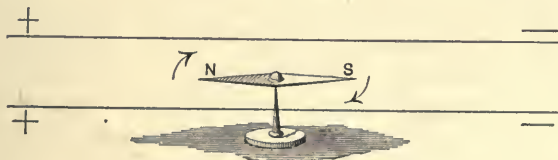

Fig. 146.

direction of the current through the conductor. A current through a conductor therefore produces a magnetic field about it. At this point the analogy between an electric current and a stream of water flowing through a pipe fails, for such a stream produces no effect in the region surrounding the pipe.

Let a current flow through the conductor above the needle *NS* from north to south as indicated (Fig. 146). The N pole will turn toward the east. If the current be reversed through this conductor, or if it pass from north to south through the conductor under the needle, the N pole

will turn toward the west. A current upward through a vertical wire near the N pole of the needle will deflect it in the direction of the arrows; that is, the N pole turns toward the east.

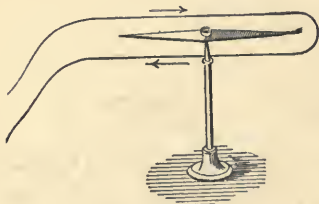

Fig. 147.

If the wire be carried round the needle in a rectangular loop (Fig. 147), both branches of it will contribute to the force of deflection, and the N-seeking pole at the left will turn toward the east.

282. Ampère's Rule.—All the movements of a magnetic needle under the influence of a current may be summed up in one rule. That of Ampère is the following: Conceive a man swimming with the electric current through a conductor and facing the needle; then the N-seeking pole will always be deflected in the direction of his left hand. Since the action between the current and the needle, like all others, is mutual, the conductor will be urged toward his right.

A somewhat more convenient "rule of thumb" for most cases is the following: Conceive the current flowing in the direction of the *extended fingers* of the outstretched *right hand*, with the palm turned *toward the needle*; then the N pole will be acted on by a magnetic force in the direction of the *extended thumb*.

283. Maxwell's Rule.—The rule suggested by Maxwell has the advantage that it expresses reciprocally the relation between the direction of the current and the direction of the deflection. Consider a right-handed screw; if

the direction of the current be that of the forward motion of the screw as it enters the nut, the positive direction of the magnetic force is the direction in which the screw turns (Fig. 148).

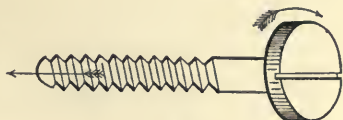

Fig. 148.

149. If the current flows in the direction of the long arrow, the resulting magnetic force is with the arrows around the circle; conversely, if the current flows around the circle with watch hands, the positive direction of the magnetic force, or the direction in which a N-seeking pole is urged, is along the axis of the circle away from the observer.

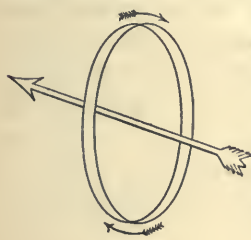

Fig. 149.

If the fingers of the closed right hand represent the circle with the current flowing out at the finger tips, the outstretched thumb points in the direction of the lines of force.

points in the direction of the lines of force.

284. Magnetic Field about a Wire. — A little consideration will show that if an observer identifies himself with the conductor, the current running from foot to head (Fig. 150), a single isolated N-seeking pole would be urged round him in a circle from right to left. The lines of force due to a current are therefore concentric circles about the conductor as a centre. Fig. 151 is made from the curves developed by iron filings on a sheet of cardboard whose plane was perpendicular to the wire. The wire is seen end-on in the figure. On gently tapping the paper the filings arrange themselves in circles.



Fig. 150.

This figure is a representation of what exists in any

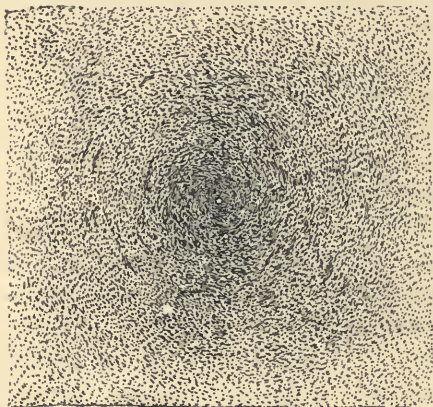

Fig. 151.

plane perpendicular to the wire. The entire region about a conductor conveying a current is therefore filled with these circular magnetic whirls. They show that the ether is under stress, and therefore possesses potential energy. It is rather more important to direct the attention to these magnetic

effects in the ether about the current than to what goes on within the conductor itself.

285. Magnetic Field about a Current through a Circular Conductor. — If the conductor be bent into a circle or a loop (Fig. 152), the

space within it possesses magnetic properties. All the lines of force pass through the loop so as to urge the N-seeking pole of a magnet downwards. The current is flowing round the loop, viewed from above, in the direction of watch hands (compare Fig. 149).

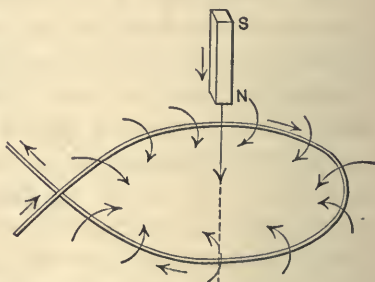

Fig. 152.

Such a loop carrying a current acts like a *magnetic*

shell; that is, one side of it attracts the N-seeking pole of a magnet and the other repels it. A magnetic shell is equivalent to a thin sheet made up of short bar magnets placed side by side with their N poles forming one surface of the plane or shell, and their S poles the other. It is known as the *lamellar* distribution of magnetism. An electric circuit is in every case equivalent to a magnetic shell whose contour coincides with the circuit. The shell is of such strength that the number of lines of force coming from it is the same as the number due to the current in the loop; that is, the magnetic shell and the closed circuit have in their vicinity identical magnetic fields. The difference between them is that the shell is impervious while the circuit is not.

286. Intensity of Field at Centre of Circular Coil.

— The intensity of the magnetic field at any point is the force acting on a unit pole placed at the point. Faraday showed that the magnetic intensity produced by a current is proportional to the current, and Biot and Savart demonstrated experimentally that for a current of indefinite extent it is inversely proportional to the distance between the conductor and the point. Laplace proved that this latter result follows from the law of inverse squares as applied to the mutual action between an element of the circuit and the pole, thus confirming the law of Ampère. Hence the intensity due to the current in an element ds of the conductor, at a point P on a perpendicular from the element, is

$$\mathcal{F} = \frac{kIds}{d^2},$$

where d is the distance between the current-element and the point P , k is the force on unit pole due to unit current at unit distance, and I is the strength of the current.

If now P is at the centre of the circle around which the current is flowing, then the intensity at the centre due to the current in the entire circumference will be

$$\mathcal{F} = \frac{kI \Sigma ds}{r^2} = \frac{2\pi r k I}{r^2} = \frac{2\pi k I}{r}.$$

If the unit current is so defined as to make k equal to unity, we have

$$\mathcal{F} = \frac{2\pi I}{r}.$$

287. **The Electromagnetic Unit of Current.** — The electromagnetic system of electrical units in common use is based on the magnetic effects of a current. *If an element of a conductor one centimetre long be bent into an arc of one centimetre radius, then the current through it will have unit strength when it exerts a force of one dyne on a unit pole at the centre of the arc.* This definition is equivalent to making k equal to unity in the last article. If the field due to unit current in unit length of the conductor is unity, the field due to the whole circumference will be 2π ; and if the current is I , it will be $2\pi I$. If, further, the radius is not unity, but r , the circumference will be $2\pi r$, and then

$$\mathcal{F} = \frac{2\pi r I}{r^2} = \frac{2\pi I}{r}.$$

The *ampere* is one-tenth of this absolute or C.G.S. unit of current. The unit of quantity in the electromagnetic system is the quantity which passes any cross-section of a conductor in one second when the current through it has unit strength. The practical unit of quantity is the *coulomb*; it corresponds with the ampere, and is one-tenth of an absolute unit.

288. Galvanometers. — We are now prepared to consider in an elementary way several types of galvanometers or instruments for measuring electric currents. When their scales are graduated so as to read directly in amperes, or when the readings reduce to amperes by the application of a simple formula, galvanometers are called *ammeters*.

There are three general types of galvanometers: (1) those in which the current flowing through a fixed coil of wire causes the deflection of a suspended magnetic needle, usually at the centre of the coil; (2) those in which the coil is movable around a vertical axis between the poles of a fixed magnet. (3) These two kinds of galvanometers are applicable to direct currents only. For both direct and alternating currents another kind is employed, in which both the fixed and the movable parts are coils. These are called *electrodynamometers*.

289. The Tangent Galvanometer. — The tangent galvanometer consists of a short magnetic needle poised at the centre of a large vertical coil with its plane in the magnetic meridian. The radius of the coil must be large in comparison with the length of the needle, which turns about a vertical axis.

The magnetic field produced by the current through the large coil is nearly uniform near its centre, and is perpendicular to the plane of the coil. For a short needle, therefore, the deflecting force is perpendicular to the horizontal component of the earth's magnetism, and its motion round a vertical axis will not carry its poles into a magnetic field of different strength. For equilibrium the moments of these two forces are equal.

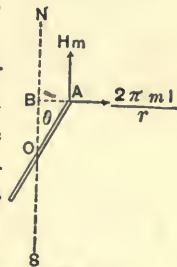

Fig. 153.

Let NS (Fig. 153) be the magnetic meridian, and the trace of the plane of the coil with its centre at O . Then the two forces acting on the pole at A of strength m are $\mathcal{H}m$ in the magnetic meridian and $2\pi mI/r$ at right angles to it; r is the radius of the coil consisting of a single turn. If l is the half-length of the needle AO , and θ the angle of deflection, then

$$\mathcal{H}m \times AB = \frac{2\pi mI}{r} \times OB,$$

or
$$\mathcal{H}ml \sin \theta = \frac{2\pi mI}{r} l \cos \theta.$$

Both m and l cancel out, and the deflection is independent of the pole-strength. From this equation

$$I = \mathcal{H} \frac{r}{2\pi} \tan \theta.$$

For n turns of wire, where n is only a small number and the n turns may be considered coincident,

$$I = \mathcal{H} \frac{r}{2\pi n} \tan \theta.$$

The fraction $2\pi/r$, or $2\pi n/r$, is called the constant of the galvanometer. It equals the strength of field produced at the centre by unit current through the coil. If this constant is denoted by G , the equation for the current may be written simply

$$I = \frac{\mathcal{H}}{G} \tan \theta.$$

I is here expressed in C.G.S. units. In amperes,

$$I = 10 \frac{\mathcal{H}}{G} \tan \theta.$$

For a uniform magnetic field the current is proportional to the tangent of the angle of deflection. The chief objection

to the use of this form of galvanometer is the variability of \mathcal{H} .

290. Nobili's Astatic Pair. — For greater sensibility the controlling couple of the earth's field on the movable magnetic system must be reduced. This may be done by means of a weak compensating magnet, either above or below the movable magnetic needle, with its N-seeking pole turned toward the north. The field produced by it at the needle is then opposed to the earth's field.

Nobili's astatic pair is another method in common use. It consists of a pair of needles (Fig. 154) mounted in the same vertical plane, but with their similar poles turned in opposite directions. If their magnetic axes were rigorously in the same plane, their lengths equal, and their poles of the same strength, such a system would stand indifferently in any azimuth. In practice neither condition is exactly met, but the system has a small directive force tending to set it in the plane of the magnetic meridian.

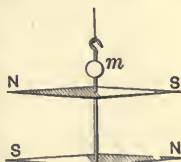

Fig. 154.

If both needles are surrounded with coils so connected that the current flows round them in opposite directions, the two forces of deflection will turn the system in the same direction, while the opposing controlling force is reduced to a small value.

291. The Astatic Mirror Galvanometer. — In Fig. 155 the coils are swung open to expose to view the astatic system. It consists of minute pieces of magnetized watchspring at the centres of the coils above and below. They are mounted on an aluminium wire, and midway between them is a small round mirror to reflect a beam of light

which serves as a long pointer. The lower set of magnets has a slightly greater magnetic moment than the upper one.

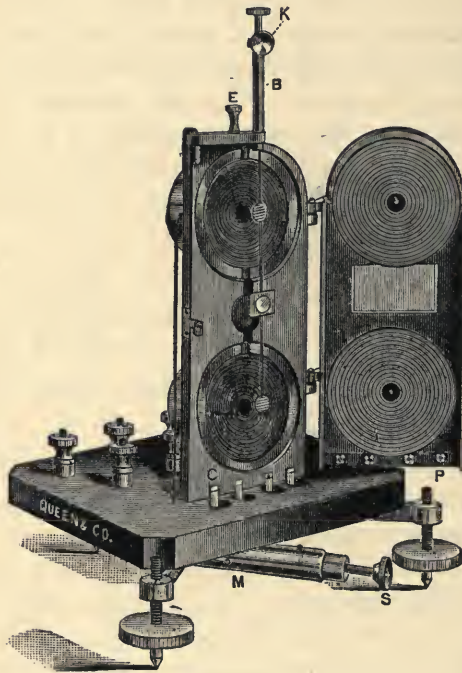

Fig. 155.

The four coils are so joined in series that the current through them operates to turn the whole system in the same direction.

The control magnet in this particular instrument is under the base. It is movable around a vertical axis, and its effective magnetic moment can be varied by turning the milled screw *S*. The screw turns two soft-iron nuts threaded on the magnet so as to

partly close its magnetic circuit, and thus alter its external field of force.

292. The d'Arsonval Galvanometer. — It is immaterial from a magnetic point of view whether the coil or the magnet of a galvanometer is made movable, since the action between them is reciprocal. The great advantage of the d'Arsonval galvanometer is that it has a strong field of its own, which is only slightly affected by the earth's

magnetism or by iron or other magnetic materials in its neighborhood. It is also possible to so shape the pole-pieces of the permanent magnet in it that the deflection shall be strictly proportional to the current through a wide range. The well-known Weston instruments are of this type.

Fig. 156 is a d'Arsonval galvanometer of the ordinary pattern. The coil swings in the strong field between the poles of the upright magnet and the cylindrical soft-iron core inside of it. It is suspended by a fine wire or thin phosphor-bronze strip, through which the current enters the coil, while a straight wire or a helix conveys it out at the bottom.

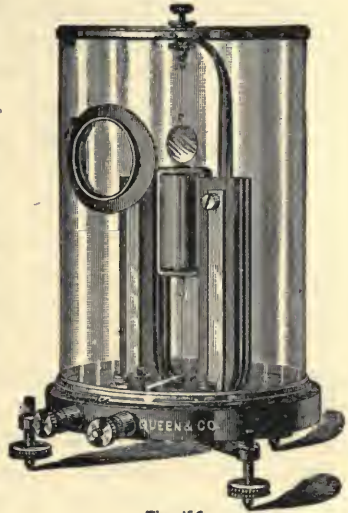

Fig. 156.

The Ayrton-Mather form of this galvanometer has a single ring magnet with only a narrow vertical opening between its poles (Fig. 157). In this opening is placed a tube containing a long narrow coil without any iron core. It is suspended as in the other form. Its plane must be parallel to the lines of force in the narrow gap in which it hangs.

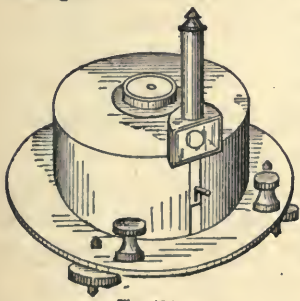
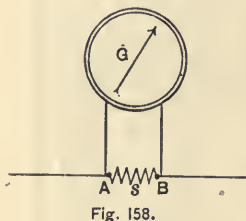

Fig. 157.

293. Potential Galvanometers. — Galvanometers used for the purpose of determining the potential difference between two points of a circuit

must be of high resistance. If they are graduated to read in volts they are called *voltmeters*. They are always connected as a shunt. Thus, if the galvanometer G (Fig. 158) is connected to the points A and B as a shunt to the resistance s , and if its resistance is high in comparison with s , so that no appreciable part of the whole current passes through the galvanometer, then the small current that



does pass through it is strictly dependent on the potential difference between A and B . Any sensitive galvanometer may be used as a voltmeter by adding a sufficiently large resistance in series with it. Unless the resistance of a voltmeter is high, the application of its terminals to two

points of a circuit, so as to put it in parallel with a resistance through which a current is flowing, will diminish the potential difference which it is desired to measure.

If the galvanometer resistance is 99 times that of the shunted resistance s , then one per cent of the current goes through the galvanometer, and the potential difference between the terminals of s is reduced one per cent.

294. Electromagnetic Units. — It will be convenient for reference to bring together the several electrical units expressed in magnetic measure in the C.G.S. system.

Unit Strength of Current. A current has unit strength when a length of one centimetre of its circuit, bent into an arc of one centimetre radius, exerts a force of one dyne on a unit magnetic pole (264) at its centre (287).

Unit Quantity of Electricity. It is the quantity conveyed by unit current in one second.

Unit Potential Difference. Unit potential difference, or

unit electromotive force, exists between two points when the transfer of unit quantity of electricity from one point to the other requires the expenditure of one erg of work.

Unit Resistance. A conductor offers unit resistance when unit potential difference between its ends causes unit current to flow through it.

Unit Capacity. A conductor has unit capacity when unit quantity charges it to unit potential.

295. Practical Electrical Units.—Several of the absolute electromagnetic units are inconveniently small and others inconveniently large for practical use. Hence the following multiples and sub-multiples of them have been generally adopted as *practical units* :

Current. The *ampere*, equal to 10^{-1} C.G.S. units; it is practically represented by the current which will deposit silver from silver nitrate at the rate of 0.001118 gm. per second (210).

Quantity. The *coulomb*, equal to 10^{-1} C.G.S. units of quantity; it is the quantity conveyed by a current of one ampere in one second.

Electromotive Force. The *volt*, equal to 10^8 C.G.S. units; it is 1000/1434 of the E.M.F. of a standard Clark cell at 15° C. (200).

Resistance. The *ohm*, equal to 10^9 C.G.S. units; a volt produces an ampere through a resistance of an ohm; practically represented by the resistance of a uniform column of mercury 106.3 cms. in length and 14.4521 gms. mass at 0° C. (220).

Capacity. The *farad*, equal to 10^{-9} C.G.S. units; it is the capacity of a condenser which is charged to a potential of one volt by one coulomb. The *microfarad*, chiefly used in practice, is one-millionth of a farad, or 10^{-15} C.G.S. units.

Work. The *joule*, equal to 10^7 ergs; it is represented by the energy expended per second by one ampere in one ohm.

Power. The *watt*, equal to 10^7 ergs per second; it is equivalent to the power of a current of one ampere flowing under an electric pressure of one volt, or one joule per second; approximately $\frac{1}{746}$ of a horse power.

Induction. The *henry*, equal to 10^9 C.G.S. units; it is the induction in a circuit when the electromotive force induced in this circuit is one volt, while the inducing current varies at the rate of one ampere per second (338).

The prefixes *kilo-* and *milli-* combined with any of the preceding units signify *a thousand* and *a thousandth* respectively. Thus a kilowatt is a thousand watts, and a millivolt is a thousandth of a volt. The prefixes *mega-* and *micro-* signify *a million* and *a millionth* respectively. Thus, a megohm is a million ohms, and a microfarad is a millionth of a farad.

CHAPTER XXII.

ELECTRODYNAMICS.

296. **Electrodynamics.** — The term *electrodynamics* is applied to that part of the science of electricity which is concerned with the force exerted by one current on another. The reciprocal action between conductors conveying currents was discovered by Ampère in 1821, shortly after Oersted's discovery of the reciprocal action between a current and a magnet. So far as demonstrated, the forces are between the conductors conveying the currents rather than between the currents themselves. Every conductor through which a current is flowing is surrounded by a magnetic field, and the magnetic fields of two such conductors react on each other.

297. **Magnetic Fields about Parallel Currents (Th., 385).** — The reciprocal action between conductors carrying currents is purely magnetic, and may be accounted for by the stresses set up in the surrounding medium. The magnetic field about a single conductor is composed of concentric circles (284); but when the fields of two conductors are in part superposed, the composite magnetic figures will be those due to the resultant of the two sets of forces in every part of the field. Moreover, these figures will exhibit attraction or repulsion between the conductors according to the relative directions of the currents through them.

Fig. 159 is the field developed by iron filings about two parallel wires passing through the two holes and with the currents flowing in the same direction. In addition to the distortion of the small circles immediately about the conductors, showing that they are crowded together on the outward sides and elongated between the wires, there are continuous curves enclosing both circuits. These are due to the coalescence of a number of circles belonging to the two currents. The conductors are drawn together by the tension along these lines of force. Midway between the two is a region where the magnetic forces represented by the circles are in opposite directions, and here the field is neutral.

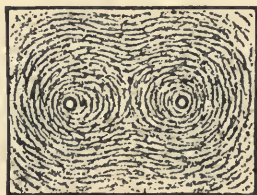

Fig. 159.

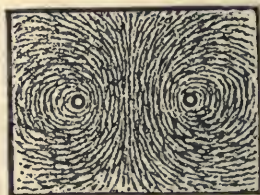

Fig. 160.

Fig. 160 is the field about two parallel conductors with the currents flowing in opposite directions. It is the same as the field through the centre of a circular conductor and perpendicular to its plane. Midway between the two wires the lines of force have the same direction in space, and produce over a small area a uniform field. This is the field utilized in the tangent galvanometer. The circles about the wires are all excentric, but there are no lines common to the two conductors; the resiliency of these lines, or their tendency to recover from the distortion, forces the conductors apart.

298. Laws of Parallel and Oblique Currents. —

I. *Parallel conductors conveying currents in the same direction attract each other; if the currents are in opposite directions they repel each other.*

This law is true for two portions of the same circuit or for two independent circuits. It depends on the relation of the two magnetic fields and not on their independent origin.

II. *Two conductors crossing obliquely attract each other if the currents in them both flow toward the point of crossing or away from it; but they repel if one flows toward and the other away from this point.*

The motion always tends to make the conductors not only parallel, but coincident. If two flat spirals, like the one in Fig. 161, be suspended by long wires so that their planes are parallel, or make a small angle with each other, they will exhibit mutual attraction and repulsion in a marked manner.

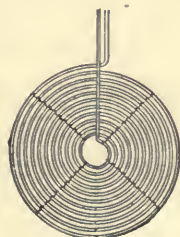

Fig. 161.

III. *The force between two parallel conductors is proportional to the product of the current strengths, to the length of the portions taken, and inversely as the distance between them.*

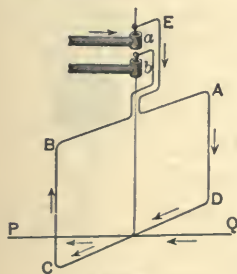

Fig. 162.

299. *Ampère's Stand.* — For the purpose of demonstrating the foregoing laws, Ampère designed a stand to hold a movable frame carrying a current (Fig. 162). At *a* and *b* are mercury cups into which dip the terminals of the balanced frame.

Another conductor placed parallel to either side of this

rectangle, or obliquely to it, will show attraction or repulsion; the same apparatus will serve to show the reaction of a magnet on a current.

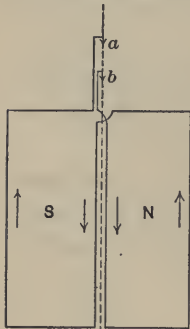

Fig. 163.

Such a circuit as the one shown in the figure tends to set its plane at right angles to the magnetic meridian, with the current flowing down on the east and up on the west side of it. The direction of its own field will then coincide with that of the horizontal component of the earth's field.

Fig. 163 is an example of an astatic circuit that is not affected by terrestrial magnetism. The left side constitutes a south pole and the right side a north pole; that is, the lines of force on the right of the figure are directed toward an observer looking at the figure, and away from him on the left. Therefore the right side is repelled by the N-seeking pole of a magnet and the left side is attracted.

300. Electromagnetic Rotations. — A large number of different devices have been designed for the purpose of showing that continuous rotations may be produced by the action between a magnet and a circuit, or between two parts of the same circuit. In the earlier apparatus one part of the circuit was made movable, and the circuit was kept closed by making connection with a liquid conductor like mercury. Fig. 164 is one of the forms designed by Faraday; a copper wire is hung by a hook at the top, and the lower end dips into a cup of mercury *M*

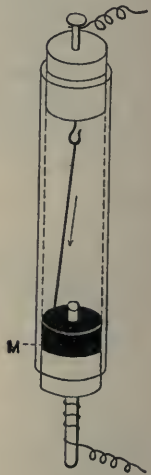

Fig. 164.

surrounding the pole of a magnet. If the current flows down through the wire, the lower end will rotate around the pole clockwise.

Barlow's wheel (Fig. 165) is another device to secure continuous rotation by the action between a magnet and a current. Contact is made by mercury in the trough *C*, and the action of the magnetic field

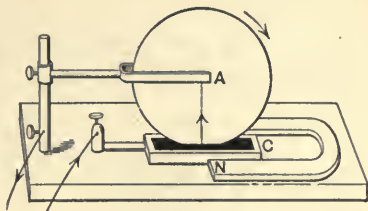

Fig. 165.

is on the radial current from the mercury to the axis *A* of the copper wheel.

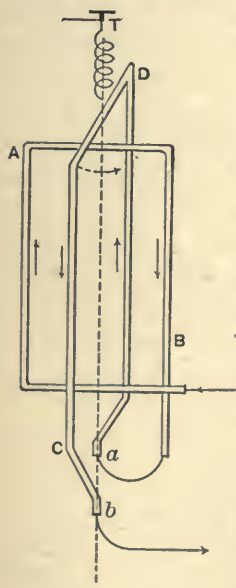

Fig. 166.

301. Electrodynamicometers.—The electrodynamicometer is an instrument designed originally by Weber to measure the strength of a current by the electrodynamic action between two coils of wire, one fixed and the other movable about a vertical axis through its own plane. The coils are set with their magnetic axes at right angles (Fig. 166), and the free coil moves in a direction to make their axes coincide.

Let *AB* be a single convolution of the fixed coil, and *CD* one of the suspended coil. The ends *a* and *b* of the latter dip into mercury cups and the two coils are in series, as shown by the arrows. The movable coil is suspended by silk threads, or on a point resting in a jewel, and a helix is rigidly connected with it and with the torsion

head T above. The movable conductor is then subjected to a system of forces tending to turn it in the direction indicated.

When the coil CD is deflected by sending a current through the instrument, the torsion head is turned by hand so as to bring the coil back to its zero or initial position.

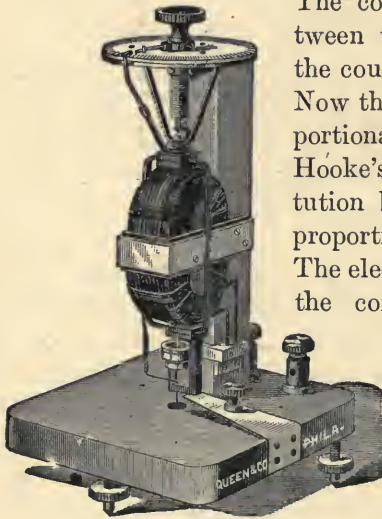

Fig. 167.

The couple due to the action between the coils is then offset by the couple of torsion of the helix. Now the couple of torsion is proportional to the angle of torsion by Hooke's law, the forces of restitution being, within elastic limits, proportional to the distortion itself. The electrodynamic action between the coils is proportional to the square of the current, since doubling the current doubles it through both coils, and therefore quadruples the force. The square of the current is then proportional to the

angle through which the counterbalancing helix is twisted, or

$$I^2 = A^2 D,$$

$$I = A\sqrt{D}.$$

A is a constant depending on the windings and the helix. Since this expression is the common equation of a parabola, if the currents and twists of the helix are plotted as coördinates, the resulting curve will be a parabola. The twist D may be expressed in any convenient divisions of a circle into equal parts.

Fig. 167 is one form of the complete instrument, showing the coils, the helix, and the scale at the top with the pointers. The movable coil is raised so that the suspending point is lifted out of the jewel bearing.

The fixed coil may be considered as furnishing a magnetic field corresponding to that of the permanent magnet in the d'Arsonval galvanometer; but in this instrument the field reverses with the current, and therefore the deflection is in the same direction whether the current goes in one direction through the instrument or the other. It may therefore be used with alternating or reversing currents as well as with direct ones.

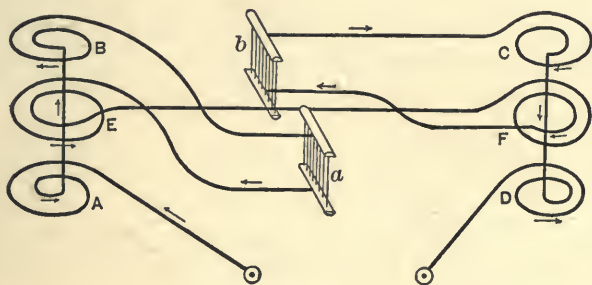

Fig. 168.

302. Kelvin Balances. — The justly celebrated instruments of Lord Kelvin for measuring currents operate by means of the electrodynamic action between parallel fixed and movable coils. This action is counterbalanced by adjustable weights or sliders instead of the torsion of a helix. They are therefore dependent on the force of gravity.

The coils are ring-shaped and horizontal. The movable rings *E* and *F* (Fig. 168) are attached to the ends of a horizontal balance beam, which is supported by two

trunnions *a* and *b*, each hung by an elastic ligament of fine copper wires. These are utilized to pass the current into and out of the movable coils. *A*, *B* and *C*, *D* are two pairs of fixed coils, connected as shown, so that the movable ring on either side is attracted by one fixed ring and repelled by the other. When a current passes through the six coils in series, the beam tends to rise at *F* and sink at *E*. It is brought back to zero by sliding a weight to the right along a graduated horizontal arm attached to the beam of the balance. The weights are so adjusted that the readings on this arm give the current either directly or else by means of a table of double square roots. The current is proportional to the square root of the reading on a scale of equal parts. These balances, like the electro-dynamometer, may be used for alternating as well as for direct currents.

303. Convection Currents. — Two concurring parallel currents attract and two like electric charges repel each other. According to Maxwell, the electrodynamic attraction should exactly equal the electrostatic repulsion when the electrical charges move with the velocity of light. According to Faraday, a stream of particles carrying electric charges has a magnetic effect like a current of electricity. This was demonstrated to be true by Rowland in 1876, who found that a charged disk, when rapidly rotated, had a feeble magnetic effect equivalent to a circular current. Conversely convection currents are acted on by magnets. The electric arc behaves like a flexible conductor. It may even be ruptured by the deflecting influence of a powerful magnet. Elihu Thomson has utilized this effect to extinguish an arc started by lightning on an electric lighting circuit.

304. **The Hall Effect.**— In 1880 Hall discovered that when a current flows through a very thin strip of metal in a powerful magnetic field, with its plane perpendicular to the lines of force, an E.M.F. appears to be developed in the strip at right angles both to the field and to the direction of the current. The result is that the lines connecting equipotential points are no longer at right angles to the lines of flow, or the equipotential lines and the current lines are both displaced. The displacement is in one direction in gold and bismuth, and in the other in iron and tellurium. S. P. Thompson has shown that bismuth, which exhibits the Hall effect in a marked degree, undergoes a change of resistance in a magnetic field. The increase of resistance shown by bismuth is so marked that this property is utilized to measure the strength of the magnetic field in which it is placed.

CHAPTER XXIII.

ELECTROMAGNETISM.

305. Solenoids. — Since a circular current is equivalent to a plane magnetic shell, if we build up a cylinder of such equal circular currents, all parallel to one another and with their similar faces all turned in the same direction, we shall have the equivalent of a cylindrical magnet.



Fig. 169.

Such a system of circular currents constitutes a *solenoid* (Fig. 169). The practical solenoid is simply a helix of a large number of flat turns close together. Each turn of the helix may be resolved into a plane circular current, ABC (Fig. 170), and a linear current AC perpendicular to the plane of the circle. The entire helix of n turns is therefore equivalent to n circular currents and a linear current along the axis of the helix. If the current returns along the axis, as in the figure, the external field is due to the circular elements only.

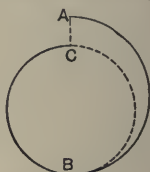
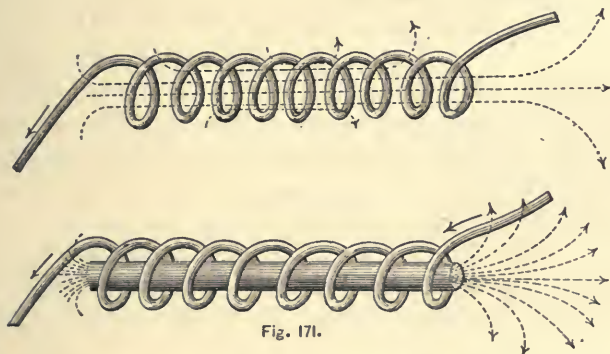

Fig. 170.

If such a solenoid be suspended on an Ampère's stand it will set its axis in the magnetic meridian when a current is passed through it. It is therefore equivalent to a magnet, and its poles can be determined by Maxwell's rule (283). Its poles will be attracted and repelled by a magnet like a magnetic needle. The direction of the current is with or against watch hands according as its S-seeking or N-seeking pole is presented to the observer.

306. **Effect of introducing Iron.** — When iron is placed in a magnetic field it becomes magnetized by induction (256). If, therefore, a bar of iron be introduced into a solenoid conveying a current, it will be magnetized by the magnetic force along the axis of the helix. The presence of the iron not only confines the lines of induction more closely to the helix, but it greatly increases the number of



them, as represented in the solenoids of Fig. 171. These solenoids are left-handed, but their poles may be determined in the usual way by the application of the “rule of thumb” (282).

307. **Electromagnets.** — Directly after Oersted’s discovery Arago and Davy independently discovered that iron and steel may be magnetized by inserting bars or strips of them into a coil of insulated wire through which an electric current circulates. If the bar be of soft iron it will exhibit notable magnetic effects only so long as the current flows through the magnetizing coil. The loss of magnetization is not complete when the current is interrupted; the small amount remaining is called *residual* magnetism.

Such temporary magnets produced by the magnetic induction within a solenoid or magnetizing helix are called *electromagnets*. When properly proportioned they are much more powerful than permanent magnets. The polarity and the relation of the poles to the direction of the current may be determined by one of the usual rules.

308. Horseshoe Magnet. — The most common form of electromagnet is the horseshoe type (Fig. 172). The windings on the two iron cylinders or *cores* must be in a direction to make the two poles of opposite signs. It is the same as if the two cores were straightened out and the bar wound continuously from end to end.

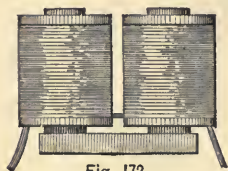

The *armature*, not shown in the figure, consists of a flat bar like the yoke at the other end, and extending across from pole to pole. Its cross-section should be equal to that of the cores. As a rule, the cores, the yoke, and the armature should form a nearly closed magnetic circuit (261). If a ring be wound continuously with a right-handed helix so as to form a closed circuit, and if connection be made with it at two points diametrically opposite (Fig. 173), and a divided current be sent through, there will be a consequent south pole where the current enters and a north pole where it leaves the ring. The lines of force about it are those of Fig. 138. The poles are consequent because they belong to two

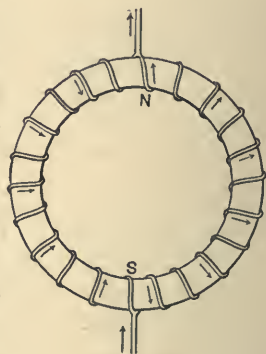

magnetic circuits, or to a divided circuit through the iron.

309. Magnetic Permeability. — The effect of placing iron in a magnetic field is to increase greatly the number of lines of induction running through the space occupied by the iron. When these lines of magnetic induction traverse the iron it is magnetized. The increase in the number of lines due to the iron may amount to several thousand per square centimetre.

Let \mathcal{B} stand for the induction, or the number of lines per square centimetre, through the iron. Then the ratio between \mathcal{B} and \mathcal{H} is called the *permeability*, or

$$\mu = \mathcal{B}/\mathcal{H},$$

where μ stands for the permeability. It expresses the fact that iron transmits the inductive effect better than air, or is more permeable. Magnetic induction is μ times the magnetic force.

310. Magnetic Susceptibility. — The intensity of magnetization is the pole strength per unit area of the polar surface (266). Magnetic *susceptibility* is the ratio between the intensity of magnetization and the strength of the field, or in symbols,

$$\kappa = \mathcal{I}/\mathcal{H}.$$

The conception involved in permeability rather than the one in susceptibility is the modern one derived from Faraday.

311. Relation between μ and κ . — Let \mathcal{H} be the number of lines of magnetic force existing in the air before the introduction of the iron. Then the iron adds to these the

lines due to a magnet of pole strength m . Hence, if s is the sectional area of the uniformly magnetized bar,

$$\mathcal{B}s = \mathcal{H}s + 4\pi m,$$

or
$$\mathcal{B} = \mathcal{H} + 4\pi \frac{m}{s} = \mathcal{H} + 4\pi \mathcal{J}.$$

Wherefore,
$$\frac{\mathcal{B}}{\mathcal{H}} = 1 + 4\pi \frac{\mathcal{J}}{\mathcal{H}},$$

and
$$\mu = 1 + 4\pi\kappa.$$

Susceptibility may be negative; but while permeability may be less than unity, it is never negative.

312. Paramagnetic and Diamagnetic Substances compared (J. J. T., 257). — The concept involved in permeability permits a clear distinction to be drawn between paramagnetic and diamagnetic substances. Paramagnetic substances are those whose permeability is greater than unity; and since the permeability of air is practically unity, paramagnetic substances are those more permeable

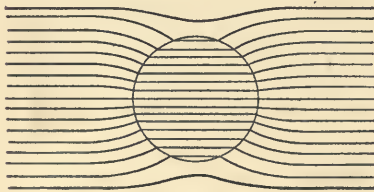

Fig. 174.

to lines of magnetic induction than air. On the other hand, diamagnetic substances have a permeability less than unity, or are less permeable than air. Permeability expresses the number of magnetic lines in the medium for every line of magnetizing force applied to produce them.

Paramagnetic substances concentrate the magnetic lines and diamagnetic substances diffuse them. If iron be placed in a magnetic field, it will cause more lines of induction to pass through than through air; but if bismuth be placed

there instead of iron, fewer lines will pass through it than through the air previous to its introduction.

If an iron sphere be placed in a uniform magnetic field (Fig. 174) the effort of the lines will be to run as much as possible through the sphere. This action proceeds on the principle that the potential energy of a system always tends to as small a value as possible; for when the same number of lines pass through iron as through air they have less energy in unit volume of iron.

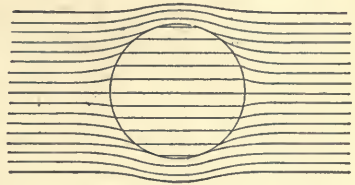

Fig. 175.

If the sphere in Fig. 175 be bismuth the effort of the magnetic lines will be to avoid it. There are fewer lines of induction in it than in air. For the same number of lines the energy per unit volume is greater in bismuth than in air.

When the lines of force pass from air to a paramagnetic substance they are bent away from the normal in the substance; but when they pass from air to a diamagnetic substance they are bent toward the normal.

313. Movement of Paramagnetic and Diamagnetic Bodies in a Magnetic Field. —

Faraday examined the magnetic behavior of a large number of bodies in the intense field between the pointed poles of a powerful electromagnet. A small bar of iron suspended between the poles (Fig. 176) turns in the axial direction ab , while a bar of bismuth sets its longer axis in the equatorial direction cd . If the

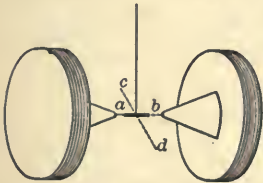

Fig. 176.

bismuth is in the form of a cube or lump it is repelled toward one side. Iron moves into the stronger parts of the field and bismuth into the weaker. They are examples of the two classes into which bodies are divided with respect to the action of magnetism on them.

These movements may be satisfactorily explained by the relative permeability of the body and the medium in which it is suspended. Feebly magnetic bodies behave as if they were diamagnetic when surrounded by a more highly magnetic medium. A small glass tube containing a weak solution of ferric chloride is paramagnetic in air; but when suspended in a stronger solution of ferric chloride, it takes a cross-position like a diamagnetic body. When, therefore, any substance assumes the equatorial position, the only inference which can justly be drawn from this behavior is that its permeability is less than that of the air or other medium surrounding it.

In general, liquids are diamagnetic; liquid oxygen and solutions of salts of the magnetic metals are exceptions.

314. Magne-crystallic Action.— In crystalline bodies the permeability may vary with the direction. Such a substance is said to be *æolotropic*. Tyndall found that the magnetic axis or line of greatest permeability in a crystal is in general an axis of greatest density, and it is this axis that tends to place itself either along the magnetic field or across it according as the crystal is paramagnetic or diamagnetic.

Directions of unequal induction or permeability can be produced artificially by pressure. Thus, a small roll of powdered bismuth, made adhesive by mixing with gun-water, will set itself across the field between the poles of the excited magnet; but if it be squeezed flat by

mechanical pressure, it will then turn in the axial position. The lines of pressure transverse to the thickness are then the lines of closest proximity of the particles and the lines of most powerful induction.

315. Magnetic Induction and Magnetic Force. — If a long iron bar be placed in a uniform magnetic field parallel to the lines of force, the lines of force in the bar are called lines of *magnetic induction*. They will be parallel to the axis of the bar in the portions distant from the ends. If a narrow crevasse perpendicular to the lines of induction be made in the bar, the flux of force in the crevasse continues as a flux of induction in the iron. In the air the flux may be considered indifferently as induction or force. Lines of induction are consequently continuous throughout the magnetic circuit. Near the ends of the bar the lines of induction have not the same direction as the lines of force of the uniform field. The poles induced in the bar produce lines of force running counter to the lines of induction in the iron. In some æolotropic substances the axis of magnetization does not coincide with the lines of force of the impressed magnetic field.

316. Curves of Magnetization. — When an iron bar or ring is subjected to a gradually increasing magnetizing force, the flux of induction through it increases at first slowly, then very rapidly, and after this very slowly. The ratio between \mathcal{B} and \mathcal{H} decreases toward a constant quantity, which equals unity in the limit. If the magnetizing force \mathcal{H} be plotted horizontally and the induction \mathcal{B} vertically, the resulting curve represents the successive stages in the magnetization of iron. In Fig. 177 *a* is the curve for mild steel, *b* for wrought iron, and *c* for cast iron.

If the ratio of \mathcal{B} to \mathcal{H} were constant, the curve of magnetization would be a straight line. Since the curve is concave toward the horizontal axis, except for very small values of \mathcal{H} , μ is not a constant, but decreases with increase of induction.

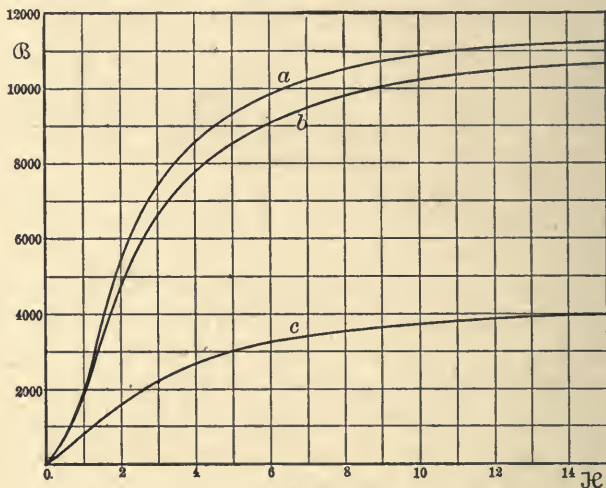

Fig. 177.

Beyond the bend of the curve the iron is said to be approaching saturation. For good soft iron this stage is reached when \mathcal{B} equals from 16,000 to 18,000 lines per square centimetre, with \mathcal{H} from 50 to 200.

317. **Hysteresis.** — If the magnetization is carried through a complete cycle by increasing the magnetizing force by successive steps from zero to some definite value, decreasing it from that value by small steps through zero to an equal value in the other direction, and then again reducing it to zero and completing the cycle, the curve

connecting \mathcal{B} and \mathcal{H} will not be the same with decreasing values of \mathcal{H} as with increasing ones (Fig. 178). The induction \mathcal{B} lags behind the magnetizing force. Thus, when \mathcal{H} is reduced to zero from its maximum positive value, \mathcal{B} has the value Ob , and \mathcal{H} must be given a negative

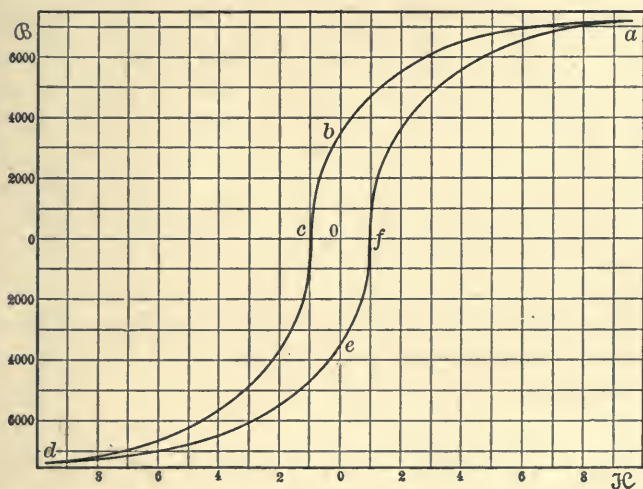

Fig. 178.

tive value equal to Oe before the induction becomes zero. So when \mathcal{H} returns from its maximum value in the other direction to zero, the induction decreases only to the value Oe . This phenomenon of the lag of the induction behind the magnetizing force Ewing has called *magnetic hysteresis*. The result of plotting the corresponding values of \mathcal{B} and \mathcal{H} through a complete cycle is a curve enclosing an area, and this area represents the heat lost per cubic centimetre in the iron in carrying it through a single cycle.¹

¹ Ewing's *Mag. Ind. in Iron and other Metals*.

318. Remanence and Coercive Force. — A cyclic magnetization curve, exhibiting hysteresis, serves among other things to give definiteness to the terms remanence or retentivity and coercive force. The residual value of \mathcal{B} when \mathcal{H} is reduced to zero is Ob (Fig. 178). This value is the *remanence*. It depends on the quality of the iron and the limit to which \mathcal{B} has been pushed. The figure relates to a closed magnetic circuit consisting of a ring. The value of \mathcal{H} required to reduce this residual induction to zero, viz., Oc , is the measure of the *coercive force*. Mechanical vibration applied by external forces has the effect of diminishing residual magnetism, coercive force, and hysteresis. If the iron in thin plates be carried rapidly through successive cycles of magnetization by alternating currents, a vibration will be set up in the plates unless they are rigidly clamped together. Any vibration resulting from this cause absorbs energy and increases the area of the hysteresis curve.

319. Law of the Magnetic Circuit. — The idea of a magnetic circuit in a vague form is older than that of an electric circuit, for it appears to go back to Euler in 1761. Later Joule¹ asserted that the resistance to induction is proportional to the length of a closed magnetic circuit; and Faraday insisted that the lines of magnetic force are always closed curves. He also made the very apt comparison of an electromagnet with open magnetic circuit to a voltaic cell immersed in an electrolyte of poor conductivity. The low permeability of the air corresponds to the low conductivity of the electrolyte.

Maxwell gave mathematical expression to Faraday's

¹ *Reprint of Sci. Papers*, Vol. I., p. 34.

ideas. He says: "In isotropic media the magnetic induction depends on the magnetic force in a manner which exactly corresponds with that in which the electric current depends on the electromotive force."¹

But the first definite expression of the law of the magnetic circuit in the form of an equation, like the equation expressing Ohm's law, was given by Rowland in 1873; he says expressly that it "is similar to the law of Ohm."²

In 1883 Bosanquet introduced the term "magnetomotive force," corresponding to electromotive force in the electric circuit. We may then write

$$\text{Magnetic flux} = \frac{\text{Magnetomotive force}}{\text{Magnetic reluctance}}.$$

Before attempting to write a more definite equation for the magnetic circuit, it is necessary to introduce certain general propositions which determine the magnetomotive force.

320. **Rotation of a Closed Circuit in a Magnetic Field.**—Conceive a current of I C.G.S. units flowing through the half circle $abcd$ (Fig. 179), and let there be a unit magnetic pole at the centre P . Then the field produced

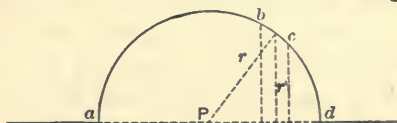

at P by the current urges the pole in a direction normal to the plane of the ring. The circuit is urged by an equal force in the opposite direction. Let bc be unit length of the curve. Then by Ampère's law of the reciprocal mechanical action between a magnet and a current, which has been experimentally demonstrated, we have

¹ *Elec. and Mag.*, Vol. II., p. 51.

² *Phil. Mag.*, Vol. XLVI., August, 1873.

(286) the force at P due to the current I in the length bc of the conductor equal to I/r^2 . Hence, the work done in rotating the arc bc through 360° about the axis ad against this force is $f \times bc \times 2\pi r'$. But this is f times the area of that portion of the spherical surface generated by bc during the rotation. Hence, the entire work done against the magnetic reaction between the whole semi-circumference and the unit pole at the centre, for one revolution, is the product of f and the surface of the sphere whose radius is r , or

$$W = f \times 4\pi r^2 = \frac{I}{r^2} \times 4\pi r^2 = 4\pi I.$$

Since 4π lines of force radiate from unit pole, and all of these are cut by the semi-circle during one rotation around the axis ad , it follows that *the work done is the product of the whole number of lines cut by the conductor and the strength of the current flowing through it.*

Suppose, further that the rotation takes place in a period t , that R is the resistance of the conductor between the points a and d , and E the potential difference between the same points. Then from the law of conservation of energy the whole electrical work done is the sum of the energy spent in heat and the work done in rotating the conductor in the magnetic field. We may therefore write

$$ERt = I^2Rt + 4\pi I$$

as the energy equation.

Therefore,
$$E = IR + \frac{4\pi}{t},$$

and

$$I = \frac{E - \frac{4\pi}{t}}{R}.$$

This is an expression for the current in the form of Ohm's

law. It shows that there is generated by the rotation an E.M.F. equal to $4\pi/t$. But this fraction is the rate at which the 4π lines of force from the unit pole are cut by the conductor. *The E.M.F. generated by a conductor cutting across lines of magnetic force is, therefore, the rate at which they are cut.*

These two propositions we have derived from Ampère's law and the conservation of energy applied to a particular case. While the method is not a perfectly general one, the results are of general application. In estimating the number of lines cut or the rate of cutting them, attention must be paid to the direction in which they are cut, and the algebraic sum must be taken in all cases.

321. Force at a Point due to a Straight Current of Indefinite Length (Th., 335). — Let ab (Fig. 180) be a portion of the straight conductor conveying a current of strength I , and let P be a point at a distance r from it. Then if we imagine a unit pole at P , and if the conductor be carried round it at the constant distance r , or the pole round the conductor at the same distance, all the lines of force from the pole will be cut once. Hence, the work done will be $4\pi I$. If the field produced by the current at the point P is \mathcal{H} , the work done is the product of the field intensity and the distance $2\pi r$, or $2\pi r \mathcal{H}$. Hence

$$2\pi r \mathcal{H} = 4\pi I,$$

or

$$\mathcal{H} = 2I/r.$$

If the current is in amperes, then the force in dynes at the point is

$$\mathcal{H} = 2I/10r.$$

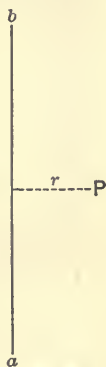

Fig. 180.

322. Force within a Helix. — Let AB (Fig. 181) represent a section through the axis of a long helix, and let unit pole be at the point P .

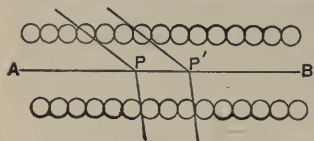

Fig. 181.

Let there be n turns of wire in a length of one centimetre parallel to the axis of the helix, each turn carrying a current I . Then if the unit pole be carried along the axis from P to P' , a distance of one centimetre, each of the 4π lines of force from this pole will be cut by n turns of wire. Hence, the whole number of lines cut will be $4\pi n$, and the work done $4\pi nI$. Since the distance moved is one centimetre, the force is numerically equal to the work, or

$$\mathcal{H} = 4\pi nI.$$

If the current is in amperes,

$$\mathcal{H} = 4\pi nI/10.$$

This is the value of the field at points distant from the ends of the helix. At the ends only half as many lines would be cut by a movement of one centimetre, and the field is only $2\pi nI/10$.

If the helix or solenoid forms a closed curve, so that there are no ends to the helix, the field along the magnetic axis will be everywhere the same.

323. Magnetomotive Force. — The electromotive force in a circuit is the work required to carry unit quantity of electricity entirely round the circuit (186). So the *magnetomotive force* is the work done in carrying a unit pole once round the magnetic circuit. If L is the length of the solenoid, the work done will be L times the strength of field or $4\pi nIL$, if the field is uniform. If it be not

uniform, then the magnetomotive force is the "line-integral" of the field intensity round the whole magnetic circuit. Now nL is the entire number of turns of wire in the solenoid. Let this be denoted by N ; then the magnetomotive force is

$$\mathcal{F} = 4\pi NI/10,$$

if the current is expressed in amperes. NI is called the *ampere-turns*. The magnetomotive force in a long solenoid is, therefore, 1.257 times the ampere-turns.

324. Reluctance (Th., 369). — The magnetic reluctance of a bar of iron is "its resistance to lines of force." It may be calculated from its length, its sectional area, and its permeability, just as the electrical resistance of a conductor may be calculated from its length, its cross-section, and its specific conductivity. Let the length of the bar be l cms., its section S square cms., and its permeability μ . Then its reluctance is

$$\mathcal{R}_0 = l/\mu S.$$

Let us apply this formula to the case of the closed circuit of an electro-magnet (Fig. 182). It is made up of two parts, the core and the armature. Let the lengths, sections, and permeabilities be denoted by l_1 , and l_2 , S_1 and S_2 , and μ_1 and μ_2 respectively. Then the reluctance of the whole circuit is

$$\mathcal{R}_0 = \frac{l_1}{\mu_1 S_1} + \frac{l_2}{\mu_2 S_2}.$$

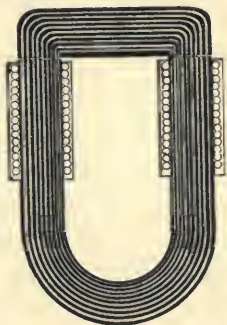

Fig. 182.

325. Law of the Magnetic Circuit applied. — When the magnetic circuit is not closed, the lines of induction must be forced across the air-gap between the faces of the iron parts of the circuit. Suppose the armature removed a short distance l_3 from the poles (Fig. 183). Then the length of the circuit is thereby increased $2l_3$ cms., and additional reluctance is introduced equal to $2l_3/S_3$, where S_3 is the cross-section of the air traversed by the induction. The permeability of the air is unity, and does not appear in the expression.

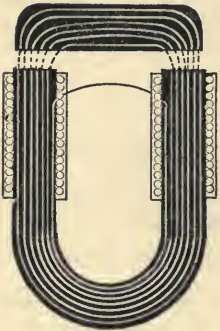

Fig. 183.

We may therefore write for the flux of magnetic induction

$$\Phi = \frac{4\pi NI}{10 \left\{ \frac{l_1}{\mu_1 S_1} + \frac{l_2}{\mu_2 S_2} + \frac{2l_3}{S_3} \right\}},$$

where I is expressed in amperes.

While this expression is simple in theory it is rendered difficult of application because μ , unlike specific conductivity, is not a constant, but is a function of the magnetization or induction in the iron. In applying the formula to any particular magnetic circuit it is necessary to know the curve of magnetization or the quality of iron used, and to ascertain from it or from tables the values of μ corresponding to the degree of saturation which it is desired to use. When this has been determined the formula gives the number of ampere-turns of excitation required. For open magnetic circuits an allowance must be made for leakage of lines of force through the air between parts of the magnet. This leakage requires excitation, but contributes nothing to the purpose for which the magnet is

designed. The allowance for it must be estimated from experience with the particular form of magnet employed. The electromagnets of dynamos are designed by a process similar to this.

326. Motion in Electromagnetic Systems.— Whenever any part of an electromagnetic system is movable, for example, the armature of an electromagnet, the tendency is always to move in a direction to reduce the magnetic reluctance and so to increase the magnetic flux. When the armature approaches the poles, the air-gap is shortened, the reluctance is diminished, and more lines of induction traverse the magnetic circuit. So when any change tends to occur in the configuration of the parts of an electromagnetic system, it is always such as to make the magnetic flux a maximum.

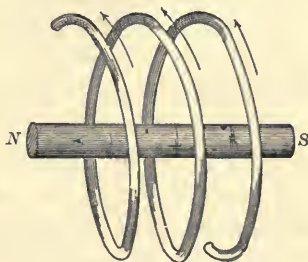

Fig. 184.

The same law may be applied to the dynamic action between conductors conveying currents. Their relative movements are in a direction to make the flux of magnetic lines around them a maximum. Hence, two circuits tend to move toward coincidence. Each is urged to a position that will make the lines of force common to the two as numerous as possible. Similar statements hold with respect to a magnet and a circuit. When a bar magnet and a helix come into a relative position where the middle point of the former coincides with the mean plane of the latter, the lines of force of the two are identical in direction through the helix, and the position is one of stable equilibrium (Fig. 184).

327. **Superficial Magnetization by Electric Discharges.**—Steel needles or small steel rods may be magnetized by the passage of an electric discharge around them, or even at right angles to their length. It has long been known that lightning flashes sometimes magnetize hard steel. If a Leyden jar be discharged through a strip of tin foil across which lies a sewing-needle, the needle will be magnetized by the discharge. Better results will be obtained by surrounding the needle with an open helix of rubber-covered wire and discharging through it. It was with simple means like these that Joseph Henry discovered the oscillatory character of the Leyden-jar discharge.

Anomalous results have sometimes been observed in the relation of the poles to the direction of the discharge around the needles or rods, the poles being turned in the direction opposite to what the rule would lead one to expect. This result is due to the oscillatory discharge combined with the superficial character of the magnetism imparted. If small steel rods, magnetized by electric discharges, be examined by removing the external portions with acid, it will be found that the magnetized part is confined to a thin shell, the underlying parts remaining unmagnetized. If a second discharge succeeds the first in the opposite direction, it will reduce the external magnetism to zero if the magnetism of half the shell is reversed. Two shells of equal magnetic moment will then be superposed in opposite senses. If therefore the reverse discharge have more than half the magnetizing effect of the first, the resultant magnetism will be apparently "anomalous;" but it is accounted for by the direct and reverse discharges, and does not constitute an exception to the law of magnetization.

Fig. 185 contains the curves obtained from two glass-hard steel rods, 6 cms. long and 1.8 mms. in diameter, magnetized by ten successive discharges of a small Leyden jar

all in the same direction.¹ The relation of the two magnetizing coils was such that the first reverse oscillation was more powerful with B than with A . The data for these curves were obtained by removing successive portions of the outside with acid and measuring the magnetic moments after each removal. Moments are plotted as ordinates, and decreasing weights as abscissas. The moment of B at first increases to a maximum, and then decreases parallel to the A -curve. B had a thin external shell magnetized in a sense opposite to that of the underlying portions. When this had all been removed, the magnetic moment was a maximum.

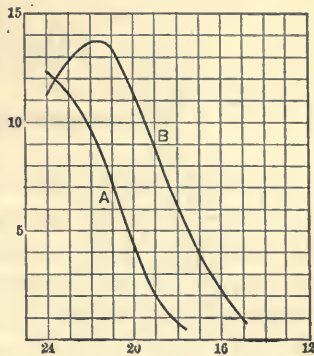

Fig. 185.

PROBLEMS.

1. An iron bar 50 cms. long and 3 cms. in diameter was magnetized to 15,780 lines per square centimetre, when μ equaled 800. Find the reluctance and the total induction through the bar.
2. A ring of soft iron 20 cms. in diameter and 3 sq. cms. sectional area is wound uniformly with a magnetizing helix. Find the number of ampere-turns required to magnetize to 13,640 lines per square centimetre, with μ equal to 2,200; what will be the total induction?
3. A straight wire carries a current of 10 amperes; find the force in dynes on a pole of strength 20 at a distance of 5 cms. from the wire.
4. A conductor is bent into a circle of 15 cms. radius; find the current through it which will deflect a short magnet at its centre 45° if the horizontal intensity of the earth's field is 0.25.
5. An electric motor is wound with 128 wires on the outside of the armature; the total magnetic flux through it is 1,250,000 lines; find the work done in ergs in one revolution when a current of 50 amperes flows through each wire; also find the power in kilowatts when there are 960 revolutions per minute.

¹ *Amer. Jour. Sci.*, XXXI., April, 1886.

CHAPTER XXIV.

ELECTROMAGNETIC INDUCTION.

328. *Faraday's Discovery.* — It has been seen that Oersted's discovery led speedily to the discovery of magnetization by electric currents, and to the mechanical action between conductors conveying them. Faraday completed this correlated group of electromagnetic phenomena by discovering in 1831 the laws of the electromagnetic induction of currents, or the laws under which induced currents are produced by means of other currents or by magnets.¹ These discoveries are of great interest, and it is of the utmost importance that the student should familiarize himself with the laws of induced currents, and should connect them with the phenomena and laws developed in the last three chapters.

Induced electromotive forces and currents are those produced by the action of magnets and other currents. Strictly only electromotive forces are induced; currents flow as a consequence when the circuit in which the electromotive force is generated is closed. But the electromotive force may still be induced whether the circuit is closed or not.

All modern methods of producing large currents for commercial purposes by dynamo machines, and all induction coils and alternate current transformers, are based on electromagnetic induction.

¹ Maxwell's *Elec. and Mag.*, Vol. II., p. 163.

329. **Induction by Magnets.** — Let a coil of insulated wire of many turns be connected to a sensitive galvanometer (Fig. 186), and thrust into it the pole *B* of a bar magnet. The galvanometer will indicate a transient current, which will continue to flow only during the motion of the magnet. If the magnet be withdrawn from the coil a transient induced current will flow in the reverse direction.

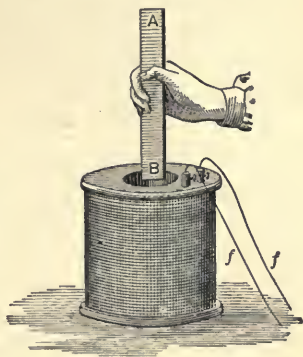

Fig. 186

When the magnet enters the coil it carries with it its lines of force, and they are therefore cut across by the spirals of the coil. Now it will be seen in Art. 320 that the reasoning there employed is independent

of the electromotive force *E*. Hence, this may be made equal to zero, and the conclusion still holds that the E.M.F. generated by cutting across lines of

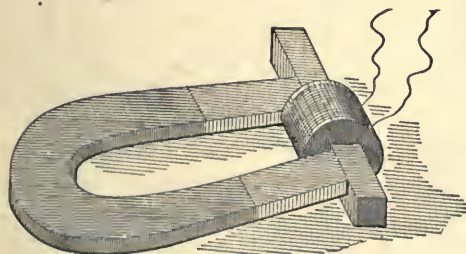

Fig. 187.

force is equal to the rate at which they are cut by the conductor. For most cases it is better to express the E.M.F. induced as *the rate of change* of the magnetic induction through an electric circuit.

If a coil of fine wire be wound around the armature of a magnet (Fig. 187), then when the armature is in contact

with the poles the flux of induction through the coils is a maximum. When it is pulled away the magnetic flux through the armature and the coil decreases rapidly, and a direct E.M.F. is generated. This experiment illustrates Faraday's method of producing electric currents by the aid of magnetism.

330. Direction and Value of an Induced Electromotive Force. — The numerical value of an induced electromotive force in C.G.S. units may be expressed as follows :

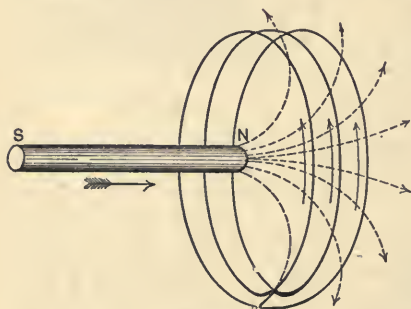

Fig. 188.

The E.M.F. induced is equal to the rate of change of the number of lines of force threading through the circuit.

If $d\Phi$ is the change in the magnetic flux through the circuit taking place in the short time dt , the induced E.M.F. is

$$E = -d\Phi/dt.$$

The minus sign indicates that a direct E.M.F. corresponds to a decrease in the flux of induction. It is to be noted that number of lines of force, magnetic induction, and magnetic flux are all equivalent expressions.

The direction of the induced E.M.F. Faraday determined by experiment, but it can be deduced from considerations with which we are already familiar. Let the magnet NS (Fig. 188) be thrust into the helix. Then if an E.M.F. is generated and a current circulates through the coil, the energy of the current must be derived from the

work done in moving the magnet. There must therefore be a resistance opposing this movement; this resistance is due to the helix considered as a magnetic shell, and the current must flow around it in a direction to make a *N* pole of the side entered by the *N* pole of the magnet. Its direction is therefore against the motion of watch-hands as indicated by the arrows. If the observer looks along the positive direction of the lines of force, a current flowing with watch-hands is said to be *direct*; if opposite to watch-hands, it is *indirect*. Therefore we have the following law relating to the direction of the induced E.M.F.:

An increase in the number of lines of force threading through a helix produces an indirect E.M.F., while a decrease in the number of lines produces a direct E.M.F.

The minus sign in the expression above corresponds to this statement.

331. Induction by Currents (J. J. T., 374).—Since a current through a solenoid produces a magnetic field equivalent to that of a magnet, the same induction effects will be produced by inserting a helix conveying a current into the long coil (Fig. 189) as by thrusting in the magnet. Let the circuit *P* include a battery and a key, and the circuit *S* a galvanometer. The former is called the *primary*, and the latter the *secondary*.

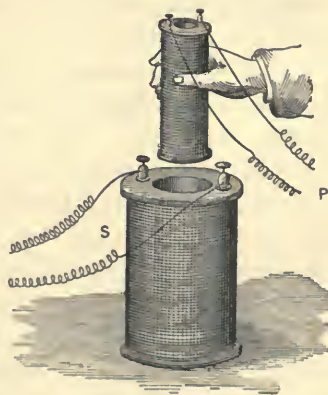

Fig. 189.

If the current through *P* is kept constant while the coil is moved about, then when *P* approaches *S* an E.M.F.

is generated in S tending to send a current in the opposite direction to that round P ; while if P is moved away from S , the E.M.F. induced in S is in the direction of the current round P . These electromotive forces in S act only so long as P is moving. If P is kept fixed while S is moved, the results are the same.

Next, let P be in a fixed position near S with the key open. Then on closing the key in P the galvanometer needle will be deflected. This deflection is not a permanent one, but the needle oscillates and finally returns to its initial position of rest, indicating the passage of a sudden discharge through the galvanometer. The direction of this momentary current is opposite to that through P . On opening the key another similar momentary current passes through S , but in the same direction as through P . Thus the starting or stopping of a current in P is accompanied by the induction of another current in a neighboring circuit S .

The sudden increase of the current in P produces an opposite current in S , and the sudden decrease of the current in P produces a current through S in the same direction as through P .

If while P remains inside of S , or coaxial with it, a bar of soft iron is placed within it, there is an increase of magnetic flux through both P and S , and the E.M.F. generated in S is in the same direction as that produced by closing the key in P , moving P toward S , or increasing the current through P . The withdrawal of the iron produces the opposite effects to its insertion in the coil.

The law of the direction and magnitude of the E.M.F. generated inductively by another current is the same as that given in the last article. When the magnetic flux changes, an E.M.F. is produced equal to the rate of change

in the magnetic flux passing through the circuit. The positive direction of the E.M.F. and of the flux through the circuit are related to each other as are the rotation and translation of a right-handed screw.

332. **Faraday's Ring.** — Faraday wound upon an iron ring two coils of wire *P* and *S* (Fig. 190). When a battery and a key were included in the circuit *P* and a galvanometer in *S*, whenever the circuit of *P* was closed or opened a momentary current was produced in the closed circuit *S*. In this experiment the iron is the medium through which the induction between *P* and *S* takes



Fig. 190.

place. The current through *P* magnetizes the iron ring as a closed magnetic circuit. The starting of the current in the circuit *P* sends magnetic lines through *S* and produces in it an inverse current; the stopping of the primary current withdraws lines and produces a direct current through the secondary. A larger deflection of the galvanometer will be produced by the first closing of the primary circuit than by opening it, or by closing it a second time unless the current be reversed. The reason is that the ring forms a closed magnetic circuit, and its retentivity or remanence is so great that only a small part of the lines of force drop out when the magnetizing current ceases to flow. But if the current through the primary be reversed, all the lines will be taken out and will be put in again the other way round. Hence, a large induction will take place in *S*. A closed magnetic circuit is not well adapted, therefore, to produce induction effects by merely opening and closing the primary circuit.

The relation between P and S is a mutual one. If S is made the primary, induced electromotive forces will be generated in P as the secondary. The Faraday ring with its two coils of wire is the type of the modern transformer for alternating currents.

333. An Inductive System a Conservative System.

— It will be instructive to look at a system of two circuits, or of a circuit and a magnet, as a conservative system. The action between the parts of the system always tends to maintain unchanged the number of lines of force threading through the circuits. Thus in Fig. 188 the approach of the magnet to the coil increases the magnetic flux through it, and the induced current is in a direction to send a counter flux through the coil so as to keep the magnetic induction through it constant. In Fig. 190 the primary current produces a magnetic flux in the ring, and the current induced in the secondary produces a magnetic flux in the other direction round the ring; that is, the induced current opposes the change in the flux.

After the magnetizing current has produced a steady magnetic flux through the iron, the opening of the primary induces a secondary current in the same direction round the ring as the primary, and this tends to maintain the flux of induction through the iron unchanged. The same principle may be applied to two coils without iron. There is no exception to the law that the induced currents are always in a direction to conserve the magnetic flux through the circuit in which the induction takes place. This law means that the magnetic flux through a circuit does not change abruptly — a property of the magnetic field analogous to inertia in matter.

334. **Lenz's Law** (J. J. T., 432; Max., II., 177).—When induced currents are produced by the motion of a conductor in a magnetic field, the circuit is acted on by a mechanical force. Lenz's law is that the direction of this force always tends to stop the motion which gives rise to it. Lenz's law is a particular case of the property of conservation described in the last article. Every action on an electromagnetic system, which involves a transformation of energy, sets up reactions tending to preserve unchanged the state of the system.

Let E be the E.M.F. generated, I the induced current, X the mechanical force parallel to the axis of x , and u the velocity of the circuit in the direction x ; then the work done on the circuit is Xu , and this is represented by the electrical activity, or the product of the current and the E.M.F.; hence

$$Xu = EI.$$

An example of Lenz's law is afforded by a coil revolving in a magnetic field. The mechanical action of the field on the current induced in the coil produces a couple tending to stop the rotation. The oscillations of the coil of a d'Arsonval galvanometer (292) subside quickly when the coil is short-circuited. The galvanometer is then a magneto-electric machine, and the currents induced in the closed coil bring it to rest.

335. **Arago's Rotations.**—When a magnet is suspended horizontally over a copper disk and the disk is rotated, induced currents are produced in it. These give rise to a force opposing the rotation. Since the force between the disk and the magnet is a mutual one, a couple acts on the magnet and turns it, if it is free to move, in the same

direction as the disk. Or if the magnet is spun round a vertical axis and the disk is movable, it is dragged after the magnet. These motions are called Arago's *rotations*;

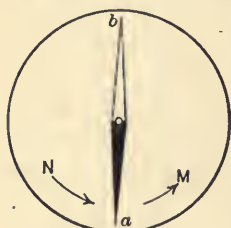

Fig. 191.

they were discovered by Arago, but were first explained by Faraday. Induced currents flow in closed circuits through the disk, and the action between them and the magnet tends to stop the disk; or if the magnet oscillates, the induced currents damp its motions. Thus in Fig. 191, if the needle *ab* oscillates over the disk as it moves in the direction of the arrows, a current is induced on the *M* side which repels the needle, and one on the *N* side attracting it; or the current under it flows from the centre toward the circumference if *a* is a N-seeking pole.

336. Other Examples of Lenz's Law. — Let a copper cube or cylinder be suspended between the pointed poles of a powerful electromagnet (Fig. 192). The cube may be set rotating by twisting the thread and releasing it. When the electromagnet is excited the cube is instantly brought to rest; it begins to spin again as soon as the current is cut off, and is again arrested on closing the circuit. This resistance to motion in a magnetic field is sometimes called magnetic friction.



Fig. 192.

In another experiment a disk of copper is made to rotate rapidly between the poles of an electromagnet (Fig. 193). When the magnet is excited the disk appears to meet with a sudden resistance. Foucault found that if it is forced to rotate it is heated by the induced currents flowing in it. These induced currents

in masses of metal are often called Foucault currents. There is a pair of eddy currents in the part of the disk passing the poles; and these currents, as in Arago's rotations, hold the disk back.

The drag due to eddy currents is proportional to the speed and to the square of the magnetic field; for the force is proportional to the field and the current, and the current is proportional to the field and the speed. When the field is constant the force is therefore proportional to the speed of rotation.

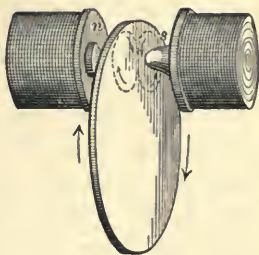

Fig. 193.

The principle is employed to produce damping in rotatory meters. A copper disk, attached to the shaft to which is connected a dial train, rotates between the poles of fixed magnets. The drag on the copper disk keeps the speed proportional to the torque.

337. Coefficient of Mutual Induction. — The preceding examples of induction by currents all belong to the class of *mutual* induction between two circuits. If we calculate the E.M.F. generated by mutual induction, we shall find that it contains a factor depending on the relative position of the two circuits, the number of turns of wire in each, and the reluctance of their common magnetic circuit.

For definiteness take the case of Faraday's ring (Fig. 190). Let N_1 and N_2 be the number of turns of wire on P and S respectively. By Art. 322 the magnetic flux through the helix P is

$$\Phi = 4\pi N_1 I / 10 \mathcal{R},$$

where I is the current in amperes and \mathcal{R} is the reluctance

of the iron ring (324). When the current is passed through the coil P , if all the magnetic lines run through S , the total number of lines cut by the N_2 turns in the secondary will be

$$N_2\Phi = 4\pi N_1 N_2 I / 10 \mathcal{F}_b.$$

The quantity $4\pi N_1 N_2 / \mathcal{F}_b$, due to the passage of one C.G.S. electromagnetic unit of current through the primary coil P , is called the *coefficient of mutual induction* M . Usually the magnetic flux through the secondary is somewhat less than that through the primary. The coefficient M then denotes the number of lines of force common to the two coils due to one C.G.S. unit of current through the primary, multiplied by the number of turns of wire in the secondary. The practical unit of mutual inductance is the *henry*. It is equal to 10^9 C.G.S. units as calculated above. Applied to mutual induction, it is the induction in the secondary when the E.M.F. induced is one volt, while the inducing current in the primary varies at the rate of one ampere per second.

Let dI/dt be the rate at which the current varies in the primary. Then

$$E = -M \cdot dI/dt.$$

E will be in volts if M is in henrys, I in amperes, and t in seconds.

338. Self-Induction. — Joseph Henry discovered that a current through a helix with parallel spirals of wire acts inductively on its own circuit, producing what he called the *extra current*. No spark is produced when such a circuit is closed, but a bright spark breaks across the gap when the circuit is opened. The effects are not very marked unless the helix contains an iron core.

Even a single circuit is a conservative system as regards

the magnetic flux through it. When the current magnetizes the core, the effect is the same as if a magnet had been plunged into the helix; that is, the induced E.M.F. is a counter E.M.F. tending to prevent the flux of magnetic induction through the circuit. The result is that the current in such a circuit does not reach its maximum value abruptly, but only after a short interval depending on the value of the *coefficient of self-induction*, or simply the *inductance*. When the circuit is opened the induced E.M.F. is direct and tends to prolong the current, or to resist the diminution in the magnetic flux.

Let there be N turns of wire on the coil. Then

$$\Phi = 4\pi NI/10\mathcal{R}.$$

The total cutting by the N spirals, if all the lines pass through them, is

$$N\Phi = 4\pi N^2 I/10\mathcal{R}.$$

This expression divided by the interval required for the change of flux to take place is the E.M.F. of self-induction. The lines cut when 10 amperes (one C.G.S. unit) pass through the coil is the value of the inductance L , or

$$L = 4\pi N^2/\mathcal{R}.$$

The value of the induced E.M.F. depends on the rate of change of magnetic flux; and since the self-induction prevents the current from reaching its steady value at once, during this variable state the rate of increase is not uniform; it is better therefore to express the inductance differently. If di/dt is the rate at which the current changes value, where i is its instantaneous value, then the induced E.M.F. is

$$e = -L \cdot di/dt.$$

The unit of inductance, the *henry*, is the inductance in a

circuit when the E.M.F. induced in this circuit is one volt, while the inducing current varies at the rate of one ampere per second.

339. Growth of Current in Inductive Circuits. — When a constant E.M.F. is impressed on a circuit possessing self-induction, the current does not attain its permanent value instantly. During the variable stage its value is not given by the simple application of Ohm's law; the inductance is another quality of the circuit, besides its resistance, which determines the instantaneous value of the current. This inductance is a property of a circuit in virtue of which the passage of a current through it is accompanied by the absorption of energy in the form of a magnetic field. If no other work is done, part of the energy flowing out from the source is converted into heat, and the rest is stored in the ether as the potential energy of the magnetic field. This storage of energy goes on while the current is rising from nothing to its steady value. The energy so stored is equal to $\frac{1}{2}LI^2$, where I is the steady value of the current given by Ohm's law.¹ The work represented by this energy is done by the current against the E.M.F. of self-induction. A circuit has large self-induction, therefore, when a relatively large quantity of energy is stored in its field while the current is rising to its final value.

The student should note that the inductance L is a con-

¹ The induced E.M.F. is $L\frac{di}{dt}$, and the work done in the element of time dt is $L\frac{di}{dt}idt$, or $Lidi$. If this expression is integrated between the limits 0 and I , the whole work done, or the energy stored in the magnetic field when the current reaches its greatest value I , is

$$\int_0^I Lidi = \frac{1}{2}LI^2.$$

stant for any given form of circuit only when this circuit consists of non-magnetic material and is surrounded by a non-magnetic medium. If it contains iron, then L changes with the value of the magnetic flux, because the reluctance is dependent on the permeability, and the permeability changes with the degree of magnetization of the iron.

340. Helmholtz's Equation. — The equation first given by von Helmholtz expresses the value of the current in an inductive circuit at any time t after a constant E.M.F. has been applied to it. If E is the impressed E.M.F., R the resistance of the circuit, i the value of the current at any time t after closing the circuit, then the effective E.M.F. required to produce the current i is Ri , and we have the equation

$$E = Ri + L \frac{di}{dt}.$$

The impressed E.M.F. is equal to the sum of the induced and effective electromotive forces. The solution¹ of this equation, if L is constant, is

$$i = I(1 - e^{-Rt/L}).$$

¹ Divide the equation of electromotive forces by R and

$$\frac{E}{R} = i + \frac{L}{R} \frac{di}{dt},$$

or

$$I - i = T \frac{di}{dt} \text{ (where } T = L/R \text{)}.$$

Whence

$$\frac{dt}{T} = \frac{di}{I - i}.$$

Integrating, $-\frac{t}{T} = \log(I - i) + \text{constant}$ ($= -\log I$, for when t is zero i is zero, and $\log I + \text{constant} = 0$).

Hence
$$-\frac{t}{T} = \log(I - i) - \log I = \log \frac{I - i}{I},$$

and

$$\frac{I - i}{I} = e^{-Rt/L},$$

or

$$i = I(1 - e^{-Rt/L}).$$

After t seconds, therefore, the current falls short of its maximum value by a quantity $Ie^{-Rt/L}$. The quotient of the inductance by the resistance L/R is called the "time-constant" of the circuit. It is the time required for the current to reach 0.632 of its final value; for when T (or L/R) equals t , Rt/L becomes unity. Then

$$1 - e^{-Rt/L} = 1 - e^{-1} = \frac{\epsilon - 1}{\epsilon}.$$

Substitute for ϵ its value 2.7183 and the expression equals 0.632. If, for example, L were 2 henrys and R 1 ohm, the time-constant would be two seconds; or in two seconds the current would rise to 0.632 of its final value. This retardation in the growth of the current is due to the fact that it has to create magnetic fields. Energy is stored up in these fields, and the resistance to the work done on them is manifested as an opposing electromotive force.

As this opposition dies away, the effective electromotive force increases, and the current rises to the value given by Ohm's law.

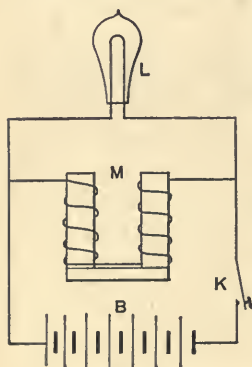

Fig. 194.

341. Energy stored in a Magnetic Field. — Let M (Fig. 194) be a large electromagnet, B a storage battery, L an incandescent lamp of a normal voltage equal to that of the battery, and K a circuit-breaker. The circuit is divided between the electromagnet and the lamp; and

since the former is of very low resistance in comparison with the latter, when the current reaches its steady state most of it will go through the coils of the magnet. The lamp is non-inductive; on closing the circuit, the self-

induction of the electromagnet acts against the current, like a large resistance, and sends most of it round through the lamp. It accordingly lights up at first, but quickly becomes dim, as the current grows to its steady value through M .

On breaking the circuit and cutting off the battery entirely, the lamp again flashes up brightly. The lamp and the electromagnet are then together on a closed circuit. The energy stored in the magnetic field, as a strain in the ether about it, is converted into electric energy, and a reverse current through the lamp lights it for an instant. This example illustrates not only self-induction, but the storage of energy in the ether about an electromagnet.

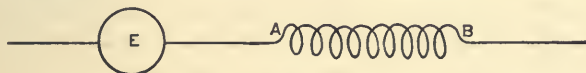

Fig. 195.

While the iron core in a helix greatly increases the self-induction, it would be a mistake to assume that the induction may not be very appreciable without it. A steady direct current was sent through an electro-dynamometer E and a coil of wire AB without an iron core (Fig. 195). The current was such that the potential difference between the terminals AB was 27 volts. The direct current was then replaced by an alternating current of the same mean square value as indicated by the electro-dynamometer (301). The energy expended on the coil AB was then the same as before, since none was absorbed by iron as heat by reason of hysteresis. The energy lost was all converted into heat, and was equal to I^2R or 27 I watts. But with an alternating current the potential difference between the terminals of

AB was 100 volts. A pressure of 100 volts was necessary to force the same current through a coil that required only 27 volts for a direct current. The difference must be ascribed to the self-induction of the coil.

342. The Induction Coil. — An induction coil is commonly employed to obtain transient electric flashes of high E.M.F. in rapid succession. In modern terms it is a step-up transformer, with open magnetic circuit. About an iron core, consisting of a bundle of fine iron wires to avoid the production of induced currents through the mass of metal in the core, is wound a primary coil of comparatively few turns of stout wire; outside of this, and as carefully insulated from it as possible, is the secondary composed of a very large number of turns of fine wire. In Spottiswood's great coil, which gave a $42\frac{1}{2}$ -inch spark, the secondary contained 280 miles of wire wound in 340,000 turns.

The primary must be provided with a circuit-breaker if the coil is to be used with direct currents. It is commonly made automatic by a vibrating device actuated by the core and similar to that of a vibrating electric bell.

In large coils the secondary is wound in flat spirals, and these are slipped on over the primary and separated from one another by insulating rings. The difference of potential between adjacent turns of wire is then not so large as when the entire coil is wound in layers from end to end, and it is easier to maintain the insulation. The ratio of the transformation of the electromotive force is nearly the same as the ratio between the number of turns of wire on the primary and secondary.

343. Action of the Coil. — While the quantity of electricity flowing through the closed secondary coil is the

same at "make" and "break" of the primary, still the E.M.F. induced in breaking the circuit is so much higher than in making it that the inductive effects are chiefly those belonging to the former. This result is brought about largely by the condenser.

On closing the primary circuit the counter E.M.F. due to self-induction reduces the time rate of change of the current on which the E.M.F. induced in the secondary depends; but on breaking the primary circuit the self-

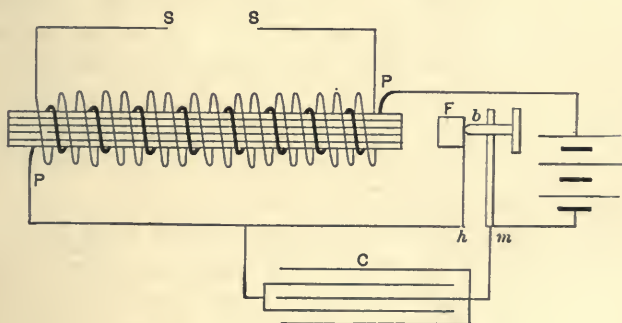

Fig. 196.

induction of the primary generates a direct E.M.F. which tends to prolong the current and prevent its abrupt fall to zero by sparking across the break. The condenser is added for the purpose of suppressing this spark and aiding in the abrupt descent of the primary current to zero. Fig. 196 represents the essential parts of an induction coil; *PP* is the primary and *SS* the secondary. The circuit is automatically opened at the point *b* by the attraction of the core on the small mass of soft iron *F*, which is mounted on a spring.

The condenser *C* is joined to the points *h* and *m* on opposite sides of the break. When the primary circuit

is opened at *b*, the extra current flows into the condenser; but as there is a complete discharge circuit for the condenser back through the primary in the opposite direction to the battery current, the condenser discharge thus aids in demagnetizing the core, or in rapidly reducing the magnetic flux by actually producing a negative one.

Lord Rayleigh has shown¹ that the best results are secured when the capacity of the condenser is just great enough to absorb a charge at a rate equal to the full delivery of the primary current during the time the break-points are separating beyond the residual sparking-distance. The condenser then causes an electric *recoil* in the current and returns the charge stored up as an equal current in the reverse direction through the primary, thus doubling the change in the flux and doubling the induced E.M.F. and current in the secondary; for the removal of all the lines of force in one direction and the insertion of them in the reverse direction amounts to a double diminution of them. The conditions are then those described by the word *resonance*. The current through the primary is rendered oscillatory by means of the condenser. Instead of absorbing the energy represented by the spark when no condenser is used, the condenser stores the energy momentarily and then returns it to the primary, and by mutual induction to the secondary, to be expended there as a longer spark or a greater current.

344. Discharges in Partial Vacua. — Many remarkable luminous effects, which are but imperfectly understood, are produced when the discharges from an induction coil pass through residual gases under a low pressure in glass vessels. Such discharges will pass through the air

¹ *Phil. Mag.*, 1870, p. 428; Fleming's *Alter. Current Trans.*, Vol. I., p. 383.

left in receivers exhausted by a good mechanical air-pump, but the best results are obtained with tubes exhausted by a mercurial air-pump to a pressure of about 2 mms. of mercury and permanently sealed. Platinum electrodes are melted into the glass at the two ends. The celebrity of the tubes made by Geissler gave to them the name "Geissler tubes." Some of the patterns are shown in Fig. 197.

The luminous effects are more intense in the narrow connecting tubes than in the larger bulbs. The cathode

exhibits a bluish or violet glow, while the light at the anode is of smaller extent, but brighter. The colors given by a gas depend on its nature. The narrow portions of a tube containing hydrogen glow with a brilliant crimson. Vapor of

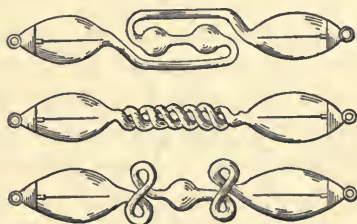

Fig. 197.

water gives the same color, indicating the dissociation of the vapor by the discharge. Tubes containing carbon dioxide emit a pale gray light, but show splendid stratifications. The glow when examined by the spectroscope gives the lines characteristic of the gas in the bulb.

Fluorescent materials in Geissler tubes are beautifully luminous. Uranium glass, and solutions of quinine, æsculin, and naphthaline-red in tubes surrounding the exhausted one, are among the best examples of fluorescent bodies. Kerosene oil also shows marked fluorescence.

The *striae* or *stratifications* of the tube consist of portions of greater luminosity separated by darker intervals. They originate apparently at the positive and become more numerous up to a definite point of the exhaustion, after which they broaden out and diminish in number. J. J.

Thomson has produced striæ throughout a tube 50 feet long, except near the cathode. They present a peculiar flickering unstable motion, similar to that sometimes observed during auroral displays. The striæ are hotter than the darker spaces between them.

345. Discharges in High Vacua. — When the exhaustion of a bulb is carried to a millionth of an atmosphere, the phenomena of the electric discharge entirely change character. Such tubes can scarcely be said to conduct at all, apparently because of some difficulty which the discharge encounters at the electrodes, for J. J. Thomson has shown that high vacua are good conductors.¹ These tubes have been investigated by Crookes with great skill, and they are therefore called “Crookes tubes.”

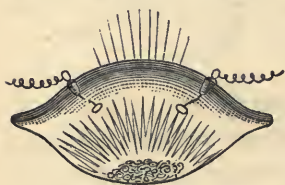

Fig. 198.

When the exhaustion has been carried to a millionth of an atmosphere, the mean free path of the molecules is increased a million fold and becomes comparable with the dimensions of the containing vessel. The disorderly motions of the molecules of the residual gas may then be directed by electrical or thermal means along definite paths. The characteristic light of a Geissler tube then almost entirely disappears by the broadening of the dark space about the cathode till it reaches the opposite wall of the bulb. The residual electrified gas is projected entirely across the bulb in radiant streams, and the bombarded walls of the tube exhibit remarkable phosphorescent effects, the color depending on the kind of glass and on

¹*Electrician*, June 7, 1895.

the substances, such as diamond, ruby, or various sulphides, subjected to this molecular cannonade (Fig 198).

Evidence is abundant that the projected molecules of the residual gas move in straight lines, except as they are deflected by a magnet or by mutual repulsion. The discharge in a Geissler tube is acted on by a magnet like a

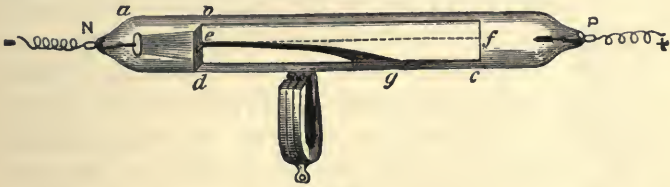

Fig. 199.

flexible conductor conveying a current; but the stream of radiant matter, as Crookes calls it, when once deflected by a magnet does not recover its former direction of motion after passing the magnet (Fig. 199).

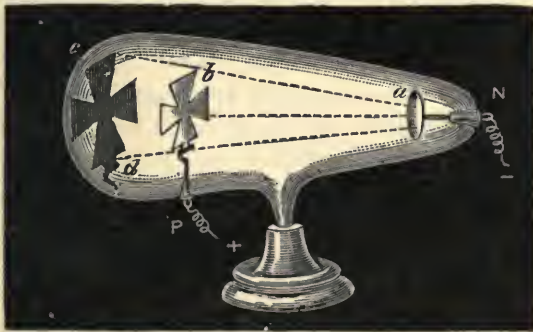

Fig. 200.

Any obstructions placed in the path of these "cathode rays" appears to stop them and casts a shadow by protecting the wall of the tube behind it from the bombardment (Fig. 200). If such obstruction consists of delicately

poised vanes, they are set moving by this molecular wind. If the cathode is made concave, the paths of the molecules cross at the focus, and glass or even platinum may be fused at this point (Fig. 201).



Fig. 201.

Two parallel streams of such flying molecules are deflected by a magnet, but repel each other like charges of the same sign. Hence their velocity is probably less than that of light, for at this speed they would act like two currents; but their electrostatic repulsion is not offset by their electrodynamic attraction as parallel currents.

346. Cathode Rays.—The projection of electrified molecules of the residual gas from the cathode plate of a Crookes tube is not the only action going on at that electrode. Hertz discovered that the emanations or “rays” from the cathode are not transmitted through mica, glass, or other transparent substances, but that they do pass through metallic foil. By means of vacuum tubes with a small window of aluminium foil at one end, Lenard demonstrated that the “rays” from the cathode pass through aluminium into the air, where they retain the remarkable property of exciting phosphorescence. Apparently these rays can be produced only in a good vacuum; but when they have passed through a medium pervious to them into the air they retain their characteristic properties. Professor Röntgen, of Würzburg, has just discovered that these cathode rays, or some unknown radiations from the phosphorescent glass, pass through opaque bodies like wood, paper, hard rubber, aluminium, etc., and

that they affect a sensitized photographic plate. In this way it has been found possible to photograph objects entirely concealed from view, such as the bones of the living hand or coins in a leather purse. These pictures are silhouettes or shadows. The unknown rays producing this effect seem not to be refrangible, and as far as now known are not reflected. Röntgen says that they originate at the part of the tube which exhibits bright phosphorescence; if so, they are not the cathode rays of Lenard, from which they are differentiated in several ways. The Lenard rays are deflected by a magnet, while the Röntgen rays are not; the former are quickly quenched in air at atmospheric pressure, while the latter can be detected at a distance of two metres from the source; the former do not pass through glass, while the latter do. Aluminium is permeable to both. Röntgen has shown that his unknown rays will pass through 200 times as thick a sheet of aluminium as of platinum.

It has long been suspected that there are longitudinal as well as transverse vibrations in the ether; some physicists have contended that they *must* exist. Röntgen is inclined to ascribe the remarkable phenomenon that he has discovered to such longitudinal disturbances in the ether.

347. **The Telephone.** — The transmitter and the receiver for the electric transmission of speech may be identical instruments, but in practice they are usually different. The transmission is commonly effected by having a rounded platinum pin pressed lightly by a delicate spring against a polished carbon surface and mounted in contact with an elastic diaphragm. This platinum-carbon contact forms part of a local electric circuit. The contact resistance is varied by the vibrations of the dia-

phragm, so that the strength of the current is modified in accordance with the aëreal movements constituting sound in the neighborhood of the mouthpiece of the instrument. The current, thus moulded by the voice, passes through the primary of a small induction coil, while the secondary pulses are sent to the transmitting line.

The receiver (Fig. 202) consists of a thin iron diaphragm *D* held in close proximity to the pole of a small electromagnet *BB*, which in turn is mounted on the end of a permanent magnet *M*. The electric pulses coming

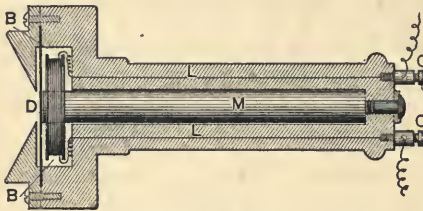

Fig. 202.

through the line actuate the electromagnet and so vary the magnetic field at the pole. When the current runs in one direction the attraction between the magnet and

the disk is increased; when it flows in the other direction it is diminished. The disk is thus forced to repeat the vibrations of the diaphragm in the transmitter, and it throws the air in contact with it into similar vibrations and reproduces the sounds.

The receiver may also be used as a transmitter. The to-and-fro motion of the iron disk, in conforming to the sound-waves impinging on it, varies the magnetic induction between it and the pole. A movement of the lines of force in the field near the end of the magnet is thus brought about; and this variation in the magnetic flux through the coil produces induced currents in it, which are transmitted to the distant station, where they actuate the receiver in the manner described.

CHAPTER XXV.

DYNAMOS AND MOTORS.

348. **Ideal Simple Dynamo.** — A dynamo is a machine for converting the energy of mechanical motion into the energy of an electric current. It is a generator of electromotive force, and is based on the principles of electromagnetic induction discovered by Faraday. It consists of a system of conductors, called an *armature*, revolving in

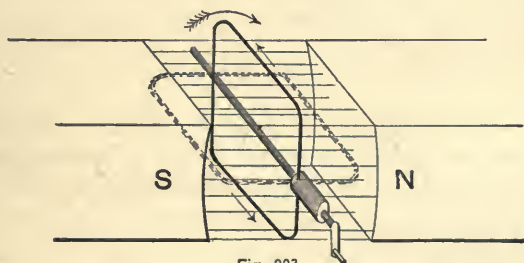

Fig. 203.

a magnetic field in such a way as to vary continuously the magnetic flux through them.

Suppose a single loop of wire to revolve in a uniform magnetic field between the poles NS of a magnet (Fig. 203) around a horizontal axis in the direction of the arrow. The loop of wire in the position in the figure encloses the maximum magnetic flux. When it has revolved through an angle θ the flux through it will be reduced to $\Phi \cos \theta$, where Φ is the maximum; for the pro-

jection of the loop on the plane perpendicular to the field varies as the cosine of the angle of displacement from that plane. After a quarter turn the loop does not enclose any lines of force; as it revolves further they thread through in the opposite direction, and this is equivalent to a continued diminution of the magnetic flux through the loop. During the second half-revolution the opposite changes take place; when the loop has revolved through 360° it returns to its initial relation to the magnetic field.

The magnetic flux through the loop varies therefore as the cosine of the angle of displacement θ . During the first half-revolution a direct current flows around the loop in the direction of the arrows; during the second half it is reversed. The E.M.F. therefore changes sign twice every revolution. Such a loop, or a coil composed of a number of parallel turns, generates an alternating electromotive force.

349. Law of the Electromotive Force. — The induced electromotive force is not equal to the total magnetic flux through the circuit, but to the rate of change of that flux. Now the total flux varies as the cosine of the angle defining the position of the loop; and when the flux is a maximum, its rate of change is a minimum and conversely. Hence when θ is zero or 180° the E.M.F. generated is zero; while for the positions 90° and 270° the E.M.F. is a maximum. The trigonometrical function that is related in this way to the cosine is the sine.¹ Hence the law of the variation of the electromotive force, generated by the revolution of the loop in a uniform magnetic field, is the same as the variation in the value of the sine of the angle of position. If, therefore, we plot uniform distances

¹The differential of the cosine is minus the sine.

along a straight line to represent equal increments of θ , and erect perpendiculars to denote the values of the corresponding sines of θ , the curve connecting the extremities of the ordinates will be a sine curve. In Fig. 204 the heavy line *I* is the cosine curve, representing the changes

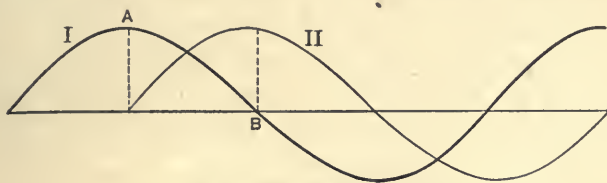

Fig. 204.

in the magnetic flux; the light line *II* is the sine curve, whose ordinates denote the rate of change of the flux, or the induced E.M.F. Their maximum values differ by 90° , or a quarter of a period. When the magnetic flux decreases through its zero value at *B*, its rate of change is greatest and there the E.M.F. is a maximum.

The current in such a loop is an alternating one, having alternately numerically equal values in opposite directions through the loop. To make it unidirectional in the external circuit a two-part commutator must be used (Fig. 205). The two parts of the split tube, insulated from each other and mounted on the shaft, are connected with the two terminals of the rotating coil. The brushes leading to the external circuit are so placed that they exchange contacts with the two commutator segments in passing through the positions where the current changes its direction through the coil. The pulses are then all in one direction in the external



Fig. 205.

circuit. Alternate loops of the sine curve are thus reversed, so that all of them lie on the same side of the zero line.

350. **The Drum Armature.** — The modern *Drum Armature* for direct currents (Fig. 206) is an evolution from the shuttle armature with a single coil. If a second coil be wound around an iron core with its plane at right angles to the first, it will generate electromotive forces differing in phase from the first by a quarter of a period.



Fig. 206.

When the two are rectified in the external circuit they combine to give a fluctuating current of twice the frequency of either, superposed on a current of constant value, so that the resulting current never drops to zero. By increasing the number of sections of the coils wound at equal angular distances around the outside of the armature core, the E.M.F. and current are rendered nearly constant in the external circuit. The sections are all joined in series and the junctions between them are connected to the commutator bars, which are insulated from one another. When the brushes bear on opposite bars, it will be readily seen that the current has two paths through the armature; so that one brush is constantly positive and the other negative. By this arrangement the potential difference between the brushes is kept up to the highest value given by half the coils in series. The brushes must

be placed near that part of the field where the E.M.F. in any coil passes through zero and reverses.

351. The Field-Magnet. — The magnetic field in direct current machines is produced by a large electro-magnet excited by a current from the armature. The residual magnetism of the cores is sufficient to start the induced current; and when the entire current is carried around the coils of the field-magnet, the dynamo is connected *in series*. The circuit of a series dynamo is shown in Fig. 207. Such a machine is adapted to furnish constant currents only; it is employed in arc-lighting.

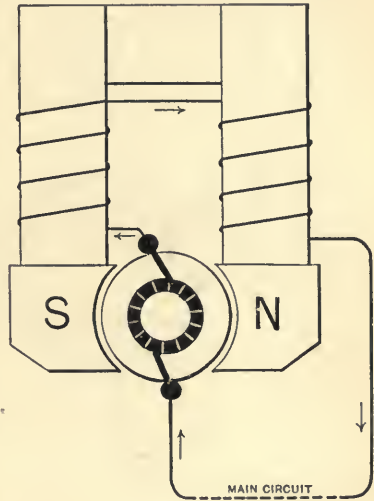

Fig. 207.

The field may also be excited by a *shunt winding*, consisting of many turns of wire connected as a shunt to the external circuit. In Fig. 208 this shunt circuit is shown connected to the brushes. It is employed on circuits requiring a constant potential difference between the main conductors. When the current changes as a result of a change in the external resistance, the excitation of the field-magnet remains nearly the same and the E.M.F. generated is therefore nearly constant.

A *compound-wound* dynamo consists of a combination of shunt and series coils on the field-magnet. It is designed to maintain the potential difference more nearly constant

than is possible with a simple shunt machine. When a current flows through the armature, there is in consequence of its resistance a loss of potential difference between the brushes.

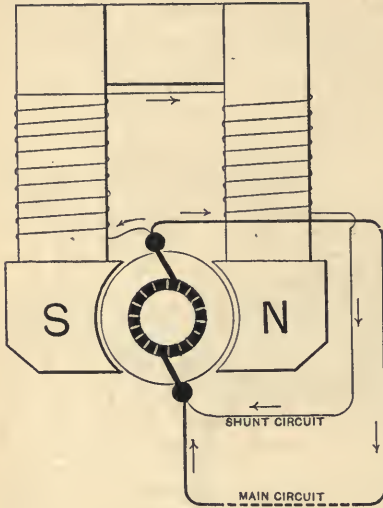

Fig. 208.

This loss occasions a further loss of voltage by reducing the exciting current through the field-magnet. Hence by carrying the whole current around the field-magnet in a series coil of a few turns, the increased excitation thus produced makes up for the loss of potential in the armature and maintains a constant potential difference between the brushes. If the armature were without resistance,

compounding would not be necessary to keep the potential difference constant at the brushes, except for the demagnetizing effect of the armature considered as an electromagnet.

An *over-compounded* machine has enough series turns to more than compensate for the loss of potential when a larger current flows through the armature. Hence the potential difference between the brushes will increase with an increase of load. The object is to compensate for a further loss of potential in the mains, so as to maintain the potential difference constant at some distant centre of distribution.

352. The Gramme Ring. — The Gramme ring is a different type of armature. It is a laminated iron ring wound continuously with a large number of turns of wire, all coiled in one direction and joined in series. Fig. 209 shows diagrammatically the relation of the several parts of the machine. The eight coils are wound right-handedly, and each junction between coils is joined to a commutator bar. In this figure the upper brush is the positive, and the current flows from it around the external circuit back to the lower brush.

When a coil is in the highest position in the figure, the maximum flux passes through it; as the ring rotates the flux through the coil de-

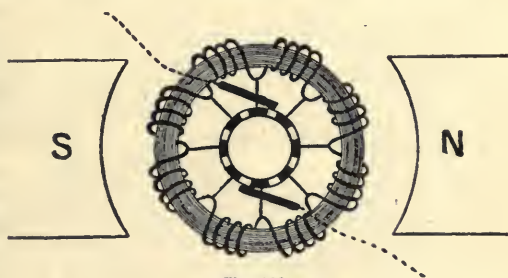

Fig. 209.

creases, and after a quarter revolution all the lines are taken out; they then begin to thread through the other way. The current through each coil reverses twice during each revolution, and there are two circuits through the armature, exactly as in the drum type. In both cases the iron, which is used to increase the magnetic flux through the armature coils, must be laminated by planes at right angles to the axis of rotation, for the purpose of preventing induction currents in the iron. These currents would heat it and waste energy.

353. Reactions in the Field of a Dynamo and a Motor. — An electric motor for direct currents is constructed in the same manner as a generator. The study

of a magnetic field through which a current is passing throws much light on the interactions between the field and the armature. Fig. 210 is the field between unlike poles distorted by a current through the loop of wire which came up through one hole and went down through the other. The lines of force are so distorted that some of them thread through the loop. Now if we conceive this loop to rotate counter-clockwise around an axis perpendicular to the plane of the paper, then it is clear that



Fig. 210.

mechanical force must be applied to keep up the motion, because the tension along the lines of force drags the loop back. The armature therefore turns against the magnetic forces or torque of the field acting on it. When used as a generator, the field of the machine is distorted in the direction of the rotation.

If, on the contrary, we conceive this loop of wire to rotate as an armature under the action of the magnetic stress on it, then the relative density of the lines in different parts of the field remains the same and the armature reverses its motion.

When the machine is used as a generator mechanical

power is converted into electrical energy, because the rotation of the armature is kept up against the internal magnetic actions in the field. Work is then done on the machine as a generator. When it is used as a motor electrical energy is converted into mechanical energy, because the rotation takes place in the direction of the magnetic effort between the field and the armature. Work is then done by the machine as a motor.

354. Direction of Rotation as a Motor.—A series machine when used as a motor runs in the opposite direction to its motion as a generator. Its rotation will be in the same direction whether the current goes through it one way or the other, since it is reversed through the armature when it is reversed through the field.

A shunt machine runs in the same direction as a motor and as a generator. If in Fig. 208 the current from an external source enters by the lower brush, as in the figure, its direction through the armature remains unchanged; but it goes through the field coils in the opposite direction to the arrows, and the armature and the field are now in parallel with reference to the external source; when used as a generator the external circuit and the field are in parallel with respect to the armature as the source of the electric pressure. The field is therefore reversed. But as a motor the machine runs *with* the magnetic torque, and as a generator *against* it; so that running with the torque when the field only is reversed is the same as running against it before the field is reversed. It is clear then that the shunt machine runs in the same direction whether it is used as a motor or a generator.

The same is true of a compound-wound machine so long as the ampere-turns of the shunt coil overbalance those of

the series; the two coils act against each other when the machine runs as a motor.

355. Counter Electromotive Force in a Motor.—The armature of an electric motor revolves in a magnetic field and generates an E.M.F. A little consideration will show that this E.M.F. must be an opposing one tending to reduce the current through it. In Fig. 211 a generator and a motor are connected together. The direction of

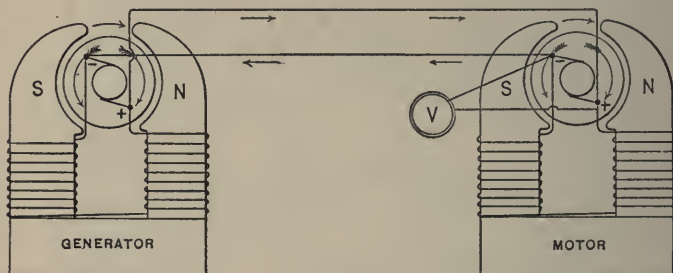

Fig. 211.

rotation in the two machines is the same. The direction of the electromotive forces generated in both armatures is shown by the arrows. They are toward the lower brush in both, because both armatures revolve in the same direction in similar fields. But in the generator the current runs in the same direction as the E.M.F. generated in its armature, while in the motor it runs against this generated E.M.F. Its own E.M.F. therefore opposes the current.

If the motor is provided with a fly-wheel to keep up its speed when the current from the generator is cut off, a voltmeter placed across its terminals, as *V* in the figure, will show only a slightly diminished E.M.F. immediately after the circuit is broken, if there is no load on the motor

to produce a quick slackening of the speed. The voltmeter shows no reversal of the current when the generator is cut off. This fact shows that the positive brush of the generator is connected to the positive of the motor, or that the E.M.F. of the motor is a back E.M.F. The voltmeter may be replaced by an incandescent lamp; it will glow nearly as brightly for a few seconds directly after the main circuit is opened as before.

356. Work done by a Motor. — We have seen in Articles 235 and 320 that the work done against an opposing E.M.F. is measured electrically by the product of this E.M.F. and the current. Now the total work done on the motor is the product of the E.M.F. applied to its terminals and the current, or EI . The difference between the two, $EI - E'I$, is the energy converted into heat (236). With an electrically perfect motor, therefore, the work done by it is the difference between the whole energy applied to it and the waste in heat, or the work done against its counter E.M.F., $E'I$.

The two factors of the power, measured mechanically, are the *torque* and the *speed*. The torque is the moment of the couple producing the rotation; it is proportional both to the strength of the field and the current in the armature. If the field is kept constant, the torque is proportional to the current, and the E.M.F. to the speed. Hence we may write

$$IE' = AnT,$$

where T is the torque, n the number of rotations per second, and A a constant.

When the motor is working under a fixed load, an increase of the field increases the torque and therefore decreases the speed n ; weakening the field on the other

hand diminishes the torque and increases the speed. Both these conclusions follow from the constancy of the product nT under the assumed condition of a fixed load. In both cases the speed changes till the counter E.M.F. acquires the same value that it had before the change was made in the field.

357. Electrical Efficiency of a Motor. — If W and W' denote the power expended on the motor and the power given out by the motor respectively, then the electrical efficiency, or conversion-factor, is

$$\frac{W'}{W} = e = \frac{IE'}{IE} = \frac{E'}{E},$$

or the ratio of the counter E.M.F. to the applied E.M.F. If the applied E.M.F. is a constant, the efficiency increases with the counter E.M.F. Now the effective E.M.F. producing the current is $E - E'$, and the larger E' the smaller is this difference and the smaller the current. When the current is small work is done at a slow rate, but a larger fraction of the power applied is spent in useful work. It is necessary to point out that this relation assumes an electrically perfect motor. Since a certain current is needed to make the motor run at the required speed without doing any useful work, the useful current is the difference between the whole current and the current required to run the motor up to speed without load. It is therefore evident that a practical motor does not have its highest commercial efficiency when working under the smallest loads, for then a large fraction of the current does not contribute to the useful work done.

The work done by a motor per second is

$$E'I = E' \frac{E - E'}{R}.$$

Since R is constant the work done will be a maximum when the product $E'(E - E')$ is a maximum. Now the sum of the two factors of this product is the applied E.M.F., E ; and when the sum of two factors is a constant their product is greatest when they are equal to each other. The condition for maximum activity is then

$$E' = E - E', \text{ or } E' = \frac{1}{2}E.$$

A motor does work at the greatest rate when the current is reduced by the counter electromotive force to half the value it would have if the motor were standing still. The efficiency is then only 50 per cent.

358. Efficiency of Transmission. — When power is transmitted to a distance electrically, high efficiency requires high electromotive force. This is equally true whether the energy is used for lighting or for power. The energy lost in the line as heat is I^2R watts, where R is the resistance of the line. To keep this waste small while the power transmitted is increased, the voltage must be raised. The current depends on the difference between the applied and the counter electromotive forces $E - E'$, while the power put into the circuit is IE watts and the power given out by the motor IE' watts. If the difference $E - E'$ is kept constant, the current and the waste in heat will remain constant, while the power transmitted will be proportional to the applied E.M.F. The factor that determines the heat waste is controlled by keeping the current small; while the other factor that enters into the measure of the power transmitted, that is, the electromotive force, is raised. The other way of reducing the energy lost in the line is to reduce the resistance; but this method involves the use of a quantity of copper the cost of which is prohibitive.

359. **Alternators.**—The armatures already described generate alternating electromotive forces that follow the law of variation of a sine curve more or less closely. A complete series of changes in the electromotive force or current represented by this curve is called a *period*, and the number of periods in a second is the *frequency* of the alternations. In two-pole machines the frequency is the same as the number of revolutions per second.

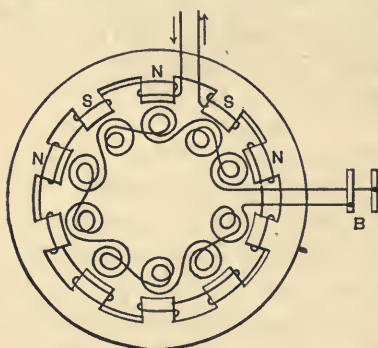

Fig. 212.

When the alternating current is utilized in the external circuit, the frequency is restricted to a lower limit of about 25 and a higher one of about 150. If the frequency is less than 25 per second the eye can detect the variations in the brightness of an incandescent lamp; while for frequencies much above 130

or 140 the effects of self-induction are greatly exaggerated. Within the above limits multipolar machines must be used to avoid excessive speed of revolution. The frequency n is then the speed of rotation multiplied by the number of *pairs of poles*.

The circuit through the armature of an alternator is of the simplest kind. The field is separately excited so that the polarity of the poles remains fixed. It will readily be seen that the successive armature coils must be so connected that the circuit reverses in direction around the coils from one to the next (Fig. 212). For high voltage they are all joined in series. A complete period is the time required for a coil to pass from one pole to the next one of the same sign.

360. Lag of Current behind the Electromotive Force.

— When an alternating electromotive force is applied to a circuit possessing inductance one of the novel and essential facts is that the current reaches its maximum value later than the electromotive force ; and, as a consequence, Ohm's law is no longer adequate to give its value. The effect of self-induction is not only to introduce an additional electromotive force, but to produce a lag of the current in phase behind the electromotive force impressed on the circuit by the generator.

Let an alternating current, following the simple harmonic law, be represented by the heavy sine curve I of Fig. 204. Then, since the induced electromotive force is proportional to the rate of change of the current when there is no iron in or about the circuit, the induced E. M. F. curve may be represented by the light line II . This is also a sine curve, since the differential coefficient of a sine function

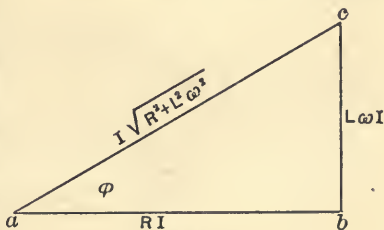

Fig. 213.

is itself a sine function. But the latter curve reaches its maximum value a quarter of a period later than the former. When the current is a maximum at A its rate of change is zero, and when it diminishes through its zero at B its rate of change is a maximum. The induced electromotive force and the current are said to be in quadrature.

The effective electromotive force producing the current by Ohm's law must correspond in phase with the current itself. The maximum induced and effective electromotive forces may therefore be represented by the two adjacent sides of a right triangle (Fig. 213), where bc

is the induced E.M.F. and ab the effective E.M.F.; the hypotenuse ac is therefore the maximum impressed E.M.F. (I., 31). But the current agrees in phase with ab ; it therefore lags behind the impressed electromotive force by the angle ϕ . In the absence of capacity in the circuit, this angle becomes zero only when the inductance is zero.

The instantaneous values of the several electromotive forces may be found by revolving the triangle around a as a centre, and projecting the three sides upon some straight line through a , as in Part I., Fig. 18.

361. Value of an Alternating Current. — The instantaneous value of an alternating current following the law of sines is

$$i = I \sin \theta = I \sin \omega t,$$

where I is its maximum value and ω the angular velocity $2\pi n$ (I., 33).

If the induced electromotive force is proportional to the change-rate of the current (338), then

$$L \cdot di/dt = L\omega I \cos \omega t,$$

since the rate of change of the sine is the cosine. This is the expression for the instantaneous value of the induced electromotive force. Its maximum value is $L\omega I$, the maximum value of the cosine of an angle being unity. Therefore in the triangle of electromotive forces (Fig. 213), the side bc equals $L\omega I$. Also ab equals RI , because it is the effective electromotive force, and by Ohm's law it is the product of the resistance and the current. Therefore ac equals $I(R^2 + L^2\omega^2)^{\frac{1}{2}}$; but the hypotenuse is the maximum impressed electromotive force. Then

$$E = I(R^2 + L^2\omega^2)^{\frac{1}{2}},$$

and

$$I = \frac{E}{(R^2 + L^2\omega^2)^{\frac{1}{2}}}.$$

The expression $(R^2 + L^2\omega^2)^{\frac{1}{2}}$ is called the *impedance*. The impedance shows that the effect of inductance on the value of the current is equivalent to additional resistance.

Also from the figure

$$\tan \phi = \frac{L\omega}{R}.$$

It is evident, therefore, that the angle of lag increases with the coefficient of self-induction L and with the frequency ($\omega = 2\pi n$). In these equations I and E denote the maximum current and impressed electromotive force. The current lags as if the angle in the auxiliary circle of reference were $\omega t - \phi$ instead of ωt . We may therefore write for the instantaneous current

$$i = \frac{E}{(R^2 + L^2\omega^2)^{\frac{1}{2}}} \sin(\omega t - \phi),$$

where the term ϕ is added to show that the current lags behind the electromotive force E .

The effect of capacity in series is to produce a lead instead of a lag of the current, and the one offsets the other when $L\omega = 1/C\omega$.¹

362. Virtual Volts and Amperes.— All practical instruments for measuring alternating currents and pressures take account of the "square root of the mean square" values and not the arithmetical mean. Thus the electro-dynamometer (301), the Kelvin balances (302), and the electrostatic voltmeter (147) all integrate the forces operating them, and these are proportional to the squares of the current and of the electric pressure. If the current and the electromotive force follow the sine law, the mean given by these instruments is 0.707 of the maximum

¹ Carhart and Patterson's *Electrical Measurements*, p. 239.

values. When a voltmeter on an alternating circuit reads 70.7, the voltage alternately rises to +100 and sinks to -100 as positive and negative maxima. The values given by these instruments are *virtual* volts and *virtual* amperes.

The virtual values exceed the arithmetical mean values by 10 per cent.¹ A continuous current and an alternating current of equal virtual value have the same heating effect; but a continuous current equal to the arithmetical mean of the alternating one will have a smaller heating effect in the ratio of 1 to 1.23 (or $\overline{.637^2}$ to $\overline{.707^2}$).

363. Choking Coils. — Consider a circuit with small resistance and large inductance. The current will then depend largely on the latter; or, if R is negligible,

$$I = E/L\omega.$$

This formula holds either for maximum or for virtual values. Coils with a divided iron core, having small resistance and large self-induction, are called *choking coils*. Thus if n were 134, L 100 henrys, and E 1,000 volts, the current through the coil of negligible resistance would be only 0.012 ampere. A current of about this value flows through the primary of a transformer on a thousand-volt circuit when the secondary is open. It is approximately independent of the resistance.

364. Wattmeters. — The measurement of power in circuits conveying alternating currents cannot be made in the same way as when continuous currents are employed,

¹ The mean of the squares of the sines throughout a half-period is 1/2. The square root of the mean square value is therefore $1/\sqrt{2}$ of the maximum, or 0.707. The mean value of the sines throughout a half-period, on the contrary, is $2/\pi$, or 0.637.

where the energy spent on any part of the circuit is measured by finding the current through it and the potential difference between its extreme points; for the potential difference and the alternating current are not in step unless the circuit is non-inductive. Thus in the example of Art. 341, the energy expended on the coil with the alternating current was apparently $100 I$ watts, while in reality it was only $27 I$ watts. When the electromotive force and current differ in phase, one of them is sometimes positive while the other is negative; hence a part of their instantaneous products are positive and part negative. During that part of the period when this product is negative the circuit is restoring power to the source. The integrated difference between the two products is the work done.

Power on alternating circuits may be measured by a wattmeter. If the movable coil of an electro-dynamometer, consisting of several turns of wire, be disconnected from the field coil and be connected in series with sufficient non-inductive resistance as a shunt to the circuit in which the power is to be measured, while the fixed coil is connected in series with this circuit, the indications of the instrument will be proportional to the integrated sum of the instantaneous products of the electric pressure and the current. When the instrument, which is then called a *wattmeter*, has been properly calibrated, it measures the power expended in watts. It is of course equally applicable to continuous currents.

365. Transformers (J. J. T., 405). — A transformer is an induction coil with a primary of many turns, a secondary of a smaller number, and a closed magnetic circuit. It is employed with alternating currents as a "step-down"

instrument for the purpose of reducing the high electromotive force on the transmitting line to a low electromotive force for lighting and power. It is entirely reversible and can be used equally well for the "step-up" process with alternating currents.

The primary and secondary coils are wound round an iron core (Fig. 214), but are insulated from each other as

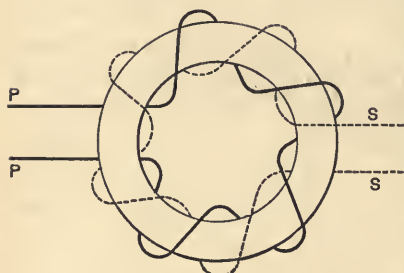

Fig. 214.

perfectly as possible. In practical transformers the iron encloses the wire rather than the reverse.

The iron serves as a path for the flux of magnetic induction. The student should notice that the relation of the current and the flux is a reciprocal

one, so that they may always exchange places. With either relative arrangement of the iron and the coils, nearly all the lines of induction produced by the primary pass also through the secondary, and *vice versa*.

When the secondary is open the transformer acts simply as a "choking coil;" the current passing through the primary is then only the very small one required to magnetize the iron for the generation of the counter E.M.F., which is then nearly equal to the impressed E.M.F. When the secondary is closed the currents in the primary and secondary are nearly in the inverse ratio of the turns of wire on the two, or N_2/N_1 , where N_1 denotes the turns on the primary and N_2 the number on the secondary. The electromotive forces generated in them, when there is no magnetic leakage, is directly as the ratio of transformation N_1/N_2 . The energy in the secondary circuit is therefore

nearly the same as that expended on the primary. The small difference is chargeable to loss in the copper of the primary and to losses in heating the iron on account of hysteresis and Foucault currents.

The secondary current is nearly opposite in phase to the primary, and causes a diminution in the apparent self-induction of the primary coil, so that the larger the secondary current the larger the primary. The transformer is therefore nearly self-governing. The power absorbed by the primary increases as the resistance of the secondary decreases; but it reaches a maximum for a particular value of the secondary resistance, below which the energy absorbed by the transformer decreases. This critical value of the resistance is larger the higher the frequency.

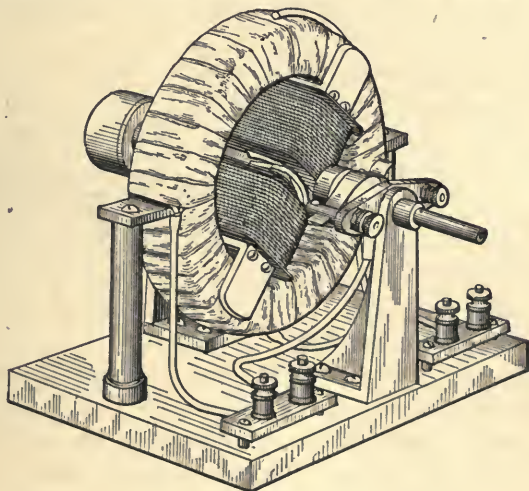

Fig. 215.

366. Polyphase Currents.—It has long been known that two or more alternating currents of the same frequency, but differing in phase by any desired quantity, may be

obtained from one generator. If, instead of a commutator, four insulated rings on the shaft be connected to four equidistant points of either a drum armature or a Gramme

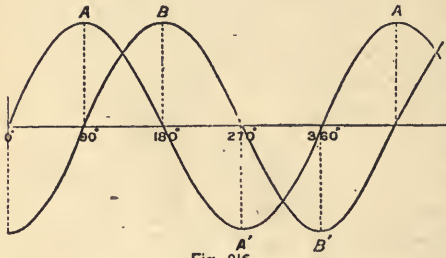

Fig. 216.

ring, the currents in the externally separate circuits will differ in phase by a quarter of a period. In the small laboratory machine of Fig. 215 the exciting current flows through the revolving field-magnet by way

of the brushes bearing on the two rings. The armature is a stationary ring wound continuously on a laminated iron core, with four conductors leading from points 90° apart. Each pair, 180° apart, compose an alternating circuit. It is obvious that one current passes through its maximum at the same instant that the other passes through its minimum value (Fig. 216).

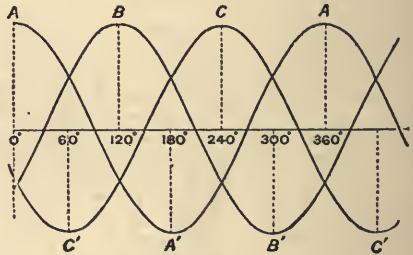

Fig. 217.

In a similar way three-phase currents will pass through conductors 120° apart. If there are but three conductors, each one serves as a return for the other two, since the algebraic sum of either two currents is at any instant equal to the third (Fig. 217).

367. The Rotatory Field. — When an alternating current passes through a coil of wire without iron it produces

an alternating magnetic field along its axis. If the current follows the sine law, the magnetic flux will follow the sine law also. Let two such coils be set with their axes at right angles, and let the equal alternating currents through them differ in phase by a quarter of a period. Two simple harmonic motions of equal amplitude, at right angles, and differing in phase by a quarter of a period, combine to produce uniform circular motion (I., 29). Hence the two coils, *AA* and *BB* (Fig. 218), will produce in a similar way a rotatory magnetic field near their common centre. Ferraris (1888) mounted within them a hollow copper

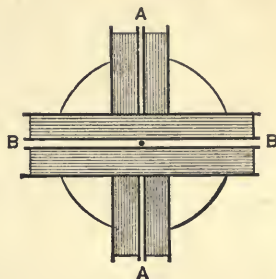

Fig. 218.

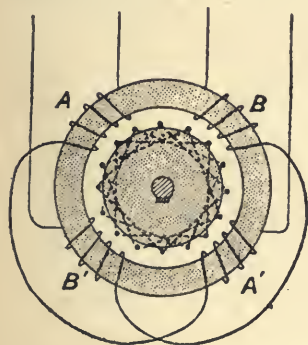

Fig. 219.

cylinder on pivots at top and bottom. When the two-phase currents from the small machine (Fig. 215) are sent through the Ferraris apparatus, the copper cylinder is set rotating. The rotation of the field produces currents in the copper, as in Arago's rotations. By Lenz's law the motion of the cylinder is in a direction to check the action going on; hence the cyl-

inder is dragged around in the same direction as the rotation of the field; for, if the speed of the cylinder were the same as that of the field, no current would be induced. If one current is reversed with respect to the other, that is, if its phase is changed by 180° , the direction of rotation of both the field and the cylinder is reversed. The cylinder

tends to run up to synchronism with the field, but never reaches it; the difference in their speeds is just sufficient to produce currents to supply the requisite torque. If the rotation of the field produces a direct E.M.F., the rotation of the cylinder, which is equivalent to the rotation of the field in the other direction, produces a counter E.M.F., and the latter is always smaller than the former.

368. **Induction Motor.** — A rotation of the field may also be produced by winding the coils of the two circuits

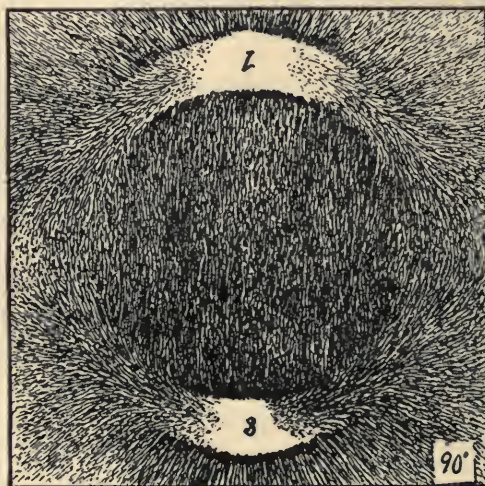

Fig. 220.

on an iron ring (Fig. 219). The coils A and A' are wound so as to make consequent poles at B and B' , while the coils B and B' produce consequent poles at A and A' . When one of these currents is a maximum, the poles in the ring are concentrated as in Fig. 220, which was made from a

photograph. Fig. 221 shows the field an eighth of a period later, when the two currents have the same instantaneous value. Both poles have spread out uniformly a quarter of the way around the ring in the direction of the rotation. As the first current diminishes further

toward zero, these broad poles contract their posterior

ends; and, after a quarter of a period, are again concentrated at points 90° in advance of the starting-point. The poles thus move round the ring by a motion which may be compared to that of a "measuring worm."

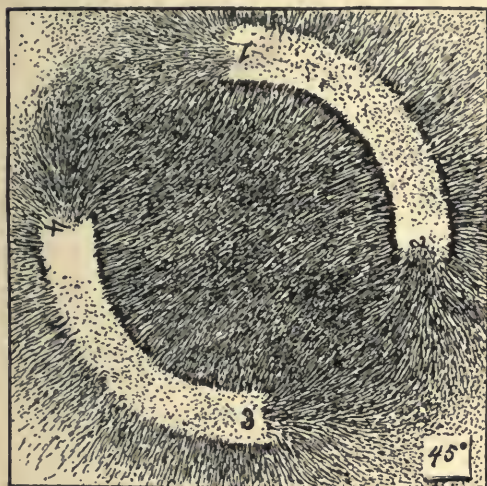

Fig. 221.

Inside the ring is mounted a "rotor," consisting of a lami-

nated iron cylinder with heavy conductors embedded in its periphery and running parallel with its axis of rotation. They are connected together at the ends of the cylinder so as to form a "squirrel-cage" of copper. The induced currents through this cage produce a torque which drags the cylinder after the rotating field. Three-phase induction motors are constructed on a similar plan (Fig. 222).

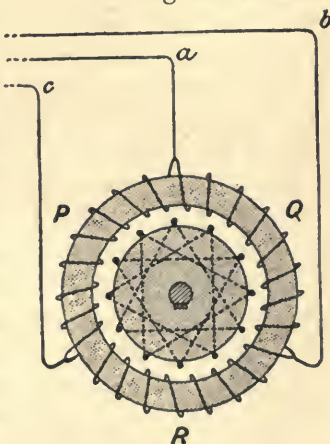

Fig. 222

CHAPTER XXVI.

ELECTRIC OSCILLATIONS AND WAVES.

369. *Oscillatory Discharges.* — Allusion has already been made to the oscillatory character of the discharge of a Leyden jar. It was discovered by Joseph Henry in 1842 by studying the singular phenomena of the magnetic effects produced by it in small steel needles, which were not always found to be magnetized in the expected direction. In 1853 Lord Kelvin gave the mathematical theory of electric oscillations, and in 1858 Fedderson analyzed the spark of a small discharge into a number of images by a revolving mirror. Such a discharge consists of electric surges first in one direction and then the other. The charge departs itself as if it possessed inertia; when the condenser is suddenly discharged through a low resistance, the first rush surges beyond the condition of equilibrium, and the condenser is charged in the opposite sense; a reverse discharge follows, and so on,—each successive oscillation being weaker than the preceding, till after a few surges the oscillations cease. That such is the character of the discharge of a Leyden jar has been abundantly demonstrated by experiment.

When the coatings are connected by a discharger of self-induction L and negligible resistance, the electrostatic energy, $\frac{1}{2}Q^2/C$, disappears and becomes the electromagnetic energy of the discharge current, $\frac{1}{2}LI^2$. This in turn is reconverted into the electrostatic energy of a reverse charge

of the jar; a second conversion into the electromagnetic form follows, and so on. Each conversion of the energy from the potential form to the kinetic or the reverse is accompanied by a loss of heat, till the energy is all expended.

The oscillations of a small Leyden jar, charged by connecting its two coatings with the secondary terminals of an induction coil, can be readily exhibited to a large number of persons. It is convenient, though not essential, to close and open the primary circuit by means of a seconds pendulum. A pointed strip of tin foil must be brought over from the inner coating of the jar so as to leave a small spark gap between it and a point connected with the outer coating. At every break of the primary circuit a spark will leap across this gap if the adjustments are properly made. If it is viewed in a four-square mirror rotating with moderate speed, it is found to consist of from about four to twelve successive images. A single observer may view it by a telescope after reflection from a mirror on the end of a tuning-fork making about 100 vibrations a second. The rate of oscillation in this case is comparatively slow on account of the large self-induction of the secondary coil, but the whole series of oscillations takes place in the "incredibly short space of time occupied by a spark."

370. Period of an Oscillation. — Whether a discharge is oscillatory or only intermittent depends on the relation between the resistance and self-induction of the discharge circuit and the capacity of the condenser.

If R denotes the resistance in ohms, L the self-induction in henrys, and C the capacity in farads, the discharge will be oscillatory when

$$R < \sqrt{4L/C}.$$

¹ *Phil. Mag.* (4) 5, p. 393.

When R is small the period of the oscillations is

$$T = 2\pi\sqrt{CL}.$$

This formula corresponds with the condition required for capacity to neutralize self-induction (361), when $L\omega = 1/C\omega$. Since $\omega = 2\pi n$ and $T = 1/n$, if we solve the equation $L\omega = 1/C\omega$ for T , we obtain the expression above for the period, $2\pi\sqrt{CL}$.

When the jar is discharged through a low resistance, oscillations take place because the choking reactions due to self-induction are neutralized by the capacity. The oscillations then continue, like the vibrations of a tuning-fork, till their energy is expended partly in heat and partly in a manner to be described presently.

371. Electrical Resonance. — If the period of oscillation of a Leyden jar is determined by its capacity and self-induction, it should be possible to apply to the phenomenon the principle of resonance in

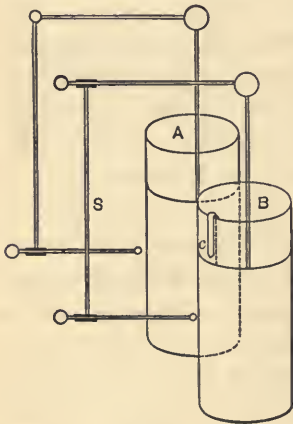

Fig. 223.

Sound (I., 151), provided the inductive effects of discharge currents are conveyed to other condensers. This has been done. The oscillatory character of a condenser discharge is demonstrated by its power of evoking oscillations of the same period in neighboring condensers. The following instructive experiment is due to Lodge:¹ Two similar Leyden jars are connected to

discharge circuits of equal size (Fig. 223); but while that

¹ *Modern Views of Electricity*, p. 338.

of *A* is interrupted by a spark gap, that of *B* is complete and is adjustable by means of the slider *S*.

If now the coatings of *A* are connected to the two electrodes of an influence machine, this jar discharges across the gap, and the oscillations at every discharge disturb the circuit of *B*, exciting in it feebler oscillations of the same period. By tuning the two circuits to unison by moving the slider, the oscillations in *B* become sufficiently violent to make it overflow through the tin-foil strip *c*, which comes over from the inner coating and nearly touches the border of the outer one. This provides an easy overflow path, so that when the jars are near together and the two discharge circuits are parallel, every discharge of *A* is accompanied by a bright spark at the air gap *c*.

372. **Electromagnetic Waves.**— When a current is established through a conductor a magnetic field is set up about it, and when the current is increased the magnetic field is increased also; the magnetic lines enlarge and new ones push out from the conductor. When the circuit is opened or reversed, these lines close in on the conductor and restore to it the energy stored in the ether through an E.M.F. of self-induction. But when the current oscillates with extreme rapidity, part of the energy radiates into space, or electromagnetic waves are set up in the surrounding medium. With the slow alternations employed commercially the loss by electromagnetic radiation is inappreciable, but such is no longer the case when the rate equals a million or more a second, as in the oscillations of a Leyden jar.

Joseph Henry appears to have been the first to detect electromagnetic waves radiating from a circuit running round a room when an inch spark from the prime con-

ductor of a frictional machine was thrown on to the end of the circuit. Sewing-needles were magnetized in a parallel circuit thirty feet below, with two floors and ceilings intervening. He says: "The diffusion of motion in this case is almost comparable with that of a spark from a flint and steel in the case of light." Thanks to the remarkable researches of Hertz, we now know it to be the same. The magnetic field produced by the discharge through the one conductor spread with the velocity of light to the closed circuit below, where a part of its energy was absorbed by cutting through the circuit, and produced an electric flow sufficient to magnetize the needles placed in the helix.

The energy stored in a Leyden jar is not all dissipated in the heat of the spark, but some of it is radiated into space in the form of electric and magnetic waves.

373. Maxwell's Electromagnetic Theory of Light. — The foundation of Maxwell's theory was laid by the experiments of Faraday in electrostatic and electromagnetic induction. These premise a medium as the agency through which induction takes place. When, therefore, a periodic disturbance, like the discharge of a Leyden jar, induces similar disturbances in conductors about it, they do not occur simultaneously with the initial one, but later and later in proportion as the conductors in which they are induced are more and more remote from the source. In other words, the inductive action proceeds from the source in the form of electric and magnetic waves.

Maxwell saw that it is not philosophical to fill all space with a new medium whenever any new phenomenon is to be explained, and that the evidence for the existence of such a medium will be strengthened if it can be shown

that the properties which must be attributed to it to account for electromagnetic phenomena are of the same kind as those which we attribute to the luminiferous ether. He therefore proposed the theory that waves of light are not mere mechanical motions, but consist of undulations partly electrical and partly magnetic; oscillating electric displacements are accompanied by oscillating magnetic forces at right angles to them; both lie in the plane of the wave, or are at right angles to its direction of propagation.

Maxwell arrived at the conclusion that the propagation of an electromagnetic disturbance through the ether takes place in accordance with the laws governing the transfer of motion through an elastic solid, and that the speed of propagation is

$$v = 1/\sqrt{\mu K},$$

where μ and K are the permeability and the dielectric constant respectively. For all transparent media μ is nearly unity. Hence the speed of light through two transparent media should be inversely as the square roots of their dielectric constants. If the velocity of light in a vacuum be taken as unity, the absolute index of refraction (I., 187) equals $1/v$. Therefore the square of the index of refraction of any substance should equal K , if the electromagnetic theory is true. The agreement between the two is not very close except for waves of great length. The index of refraction corresponding to waves of longest period should be selected, because these are the only ones whose motion can be compared with the slow processes by which the capacity of the dielectric is determined.

According to the same theory the velocity of propagation should be the number of electrostatic units of quantity in one electromagnetic unit. Michelson's value

for the speed of light (1882) is 2.9985×10^{10} , and Rowland's determination of the ratio v is 2.9815×10^{10} , both in centimetres per second. So far, therefore, the probabilities favored Maxwell's theory, but no decisive test had been applied.

374. Hertz's Researches.¹— To Hertz belongs the credit of having put the theory of electromagnetic waves to the test of experiment, and of demonstrating the truth

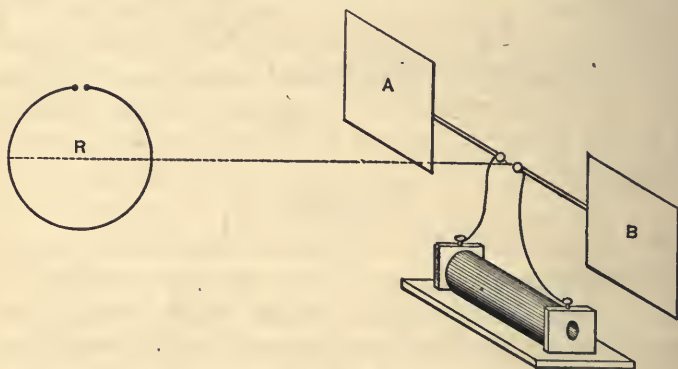

Fig. 224.

of Maxwell's theory of light. The simplicity of his appliances is no less remarkable than the magnitude of the results derived from them. With the insight of genius he seized on the only available means of producing electric waves short enough to be measurable, viz., the disturbances propagated outward from the discharge of a condenser of small capacity.

Hertz's apparatus to serve as the source of the waves he called an *oscillator* (Fig. 224). It consisted of two metallic plates *A* and *B* 40 cms. square and mounted 60 cms.

¹ Hertz's *Electric Waves*, Trans. by D. E. Jones.

apart. The balls at the spark gap were kept brightly polished. The receiver, or *resonator*, was a circle 70 cms. in diameter, and its spark gap was adjustable by means of a micrometer screw. The oscillator was connected to the induction coil. The plates formed a condenser of small capacity with air as the dielectric, and the discharge across from ball to ball was oscillatory. This oscillation had a definite period, and hence a succession of electrostatic and electromagnetic waves of equal period were emitted by it. The half period was $1/100,000,000$ of a second.

The finite speed of the wave was demonstrated by placing a large sheet of zinc on a distant wall of the room and observing the sparks produced at the small break in the resonator in different positions along the dotted base line. The metal acted as a reflector, so that stationary waves were produced by interference between the direct and reflected waves precisely as in Sound. The nodes and antinodes were detected with considerable precision. The distance between them determined the wave-length, and the product of the wave-length and the frequency of the oscillation gave the velocity. This was found to be of the same order of magnitude as the known velocity of light, though the data for calculating the period are somewhat uncertain. Professor Trowbridge has since measured the velocity of electric waves by a direct method, with a result agreeing very well with the velocity of light.

By the aid of large parabolic zinc reflectors Hertz demonstrated that electric waves are reflected to a focus in the same manner as light. He also constructed a huge prism of asphaltum and measured its index of refraction. Gratings consisting of parallel conducting bars exhibited polarization effects.

Thus Hertz demonstrated that the waves radiating from an oscillatory discharge spark and the associated condenser are capable of reflection, refraction, and polarization the same as light. They possess all the characteristics of light, and are light except in point of wave-length. Maxwell's theory does not replace the undulatory theory of light, but supplies the mechanism of the undulations.

375. Faraday's Magneto-optic Rotations.—The first definite relation between light and magnetism was established by Faraday in 1845. A beam of plane polarized light is transmitted through a transparent diamagnetic medium. When a magnetic force is made to act in the direction of the rays of light within the medium, the plane of polarization is rotated in the direction in which the current must circulate around the beam to produce the given magnetic field.

Let a beam of light, polarized by transmission through a Nicol's prism (I., 229), pass through a prism of heavy glass (borosilicate of lead), with parallel polished ends and placed in a powerful magnetic field, whose direction coincides with that of the beam of light. A second Nicol's prism as an analyzer receives the beam, and is turned so as to cut off all the light. The glass can be conveniently placed in the magnetic field by boring holes through the pole pieces attached to a large electromagnet. The holes and the glass prism are all arranged in line for the transmission of the polarized light.

When the magnet is excited light passes through the analyzer. It may be extinguished by rotating it through a small angle, but it will not be possible to produce complete extinction; colors will appear, showing that the angle of rotation is a function of the wave-length. It is nearly

inversely as the square of the wave-length. If the electromagnet is large, it will be evident that time is required to magnetize it, inasmuch as the transmitted light grows sensibly in intensity for a second or more after closing the circuit through the coils. On the other hand, Professor Lodge has shown that the rotation of the beam of light, first in one direction and then in the other, follows the oscillations of the discharge of a Leyden jar through the coils producing the field without iron.

376. Verdet's Constant. — The angle through which the plane of polarization is turned depends on the following:

(1) It is proportional to the distance which the beam travels within the medium. The direction of the plane of polarization therefore changes continuously from incidence to emergence.

(2) It depends on the nature of the medium. In some paramagnetic substances it is opposite in direction to the current producing the magnetization.

(3) It is proportional to the resolved part of the magnetic field in the direction of the beam.

This last fact was discovered by Verdet. The three laws may be combined in one formula,

$$\theta = w l \mathcal{H} \cos a,$$

where w is Verdet's constant determined by the nature of the substance. $\mathcal{H} \cos a$ is the component of the field in the direction of the beam, and l is the distance between the points of incidence and emergence. The expression $l \mathcal{H} \cos a$ is the difference in magnetic potential between the point where the beam of light enters and leaves the medium. Lord Rayleigh found for carbon bisulphide at

18° C. the constant 0.04202 in minutes of arc for a magnetic potential difference of one C.G.S. unit.

377. **Explanation of Magneto-optic Rotation.** — A ray of plane polarized light may be resolved into two circularly polarized rays of the same period, each of half the amplitude of the plane rectilinear vibration, and with the motions in opposite directions round the circles (I., 32). If now one of these circular vibrations be accelerated the plane of the resultant rectilinear harmonic motion will be rotated in the direction of the accelerated circular component, since the resulting motion always lies in the plane of symmetry. The circular vibration in the direction of the rotation performs a larger number of vibrations within the transparent medium than the other one. This mode of stating what has taken place is independent of any theory of light, and depends only on facts ascertained by experiment.

The direction of the rotation in space is the same whether the light passes one way or the other through the magnetic field. Hence the effect may be increased by passing the same beam back and forth by reflection along the same magnetic field.

Magnetism consists of something in the ether analogous to a whirl. This whirl apparently increases one of the circular components of the plane polarized beam and so rotates the plane of polarization.

APPENDIX.

TABLE I.

Absolute Dilatation of Mercury (S., 51).

Temp. by air ther- mometer.	Dilatation from 0° to t° C.	Mean coefficient between 0° and t° C.	Coefficient referred to vol. at 0°.	True coefficient.
000017905	.00017905
10	.001792	.00017925	.00017950	.00017922
20	.003590	.00017951	.00018001	.00017938
30	.005393	.00017976	.00018051	.00017955
40	.007201	.00018002	.00018102	.00017972
50	.009013	.00018027	.00018152	.00017989
60	.010831	.00018052	.00018203	.00018006
70	.012655	.00018078	.00018253	.00018024
80	.014482	.00018102	.00018304	.00018041
90	.016315	.00018128	.00018354	.00018059
100	.018153	.00018153	.00018405	.00018076
110	.019996	.00018178	.00018455	.00018092
120	.021844	.00018203	.00018505	.00018109
130	.023697	.00018228	.00018556	.00018125
140	.025555	.00018254	.00018606	.00018142
150	.027419	.00018279	.00018657	.00018159
160	.029287	.00018304	.00018707	.00018175
170	.031160	.00018329	.00018758	.00018190
180	.033039	.00018355	.00018808	.00018206
190	.034922	.00018380	.00018859	.00018221
200	.036811	.00018405	.00018909	.00018237
210	.038704	.00018430	.00018959	.00018252
220	.040603	.00018456	.00019010	.00018267
230	.042506	.00018481	.00019061	.00018282
240	.044415	.00018506	.00019111	.00018297
250	.046329	.00018531	.00019161	.00018313
260	.048247	.00018557	.00019212	.00018327
270	.050171	.00018582	.00019262	.00018341
280	.052100	.00018607	.00019313	.00018355
290	.054034	.00018632	.00019363	.00018370
300	.055973	.00018658	.00019413	.00018384
310	.057917	.00018683	.00019464	.00018398
320	.059866	.00018708	.00019515	.00018412
330	.061820	.00018733	.00019565	.00018426
340	.063778	.00018758	.00019616	.00018440
350	.065743	.00018784	.00019666	.00018453

TABLE II.

Volume and Density of Distilled Water after Rosetti (S., 54).

Temperature.	Volume.	Density.	Temperature.	Volume.	Density.
— 10°	1.001858	.998145	14°	1.000701	.999299
— 9	1.001575	.998427	15	1.000841	.999160
— 8	1.001317	.998685	16	1.000999	.999002
— 7	1.001089	.998911	17	1.001160	.998841
— 6	1.000883	.999118	18	1.001348	.998654
— 5	1.000702	.999298	19	1.001542	.998460
— 4	1.000545	.999455	20	1.001744	.998259
— 3	1.000410	.999590	21	1.001957	.998047
— 2	1.000297	.999703	22	1.002177	.997826
— 1	1.000203	.999797	23	1.002405	.997601
0	1.000129	.999871	24	1.002641	.997367
1	1.000072	.999928	25	1.002888	.997120
2	1.000031	.999969	26	1.003144	.996866
3	1.000009	.999991	27	1.003408	.996603
4	1.000000	1.000000	28	1.003682	.996331
5	1.000010	.999990	29	1.003965	.996051
6	1.000030	.999970	30	1.004253	.995765
7	1.000067	.999933	40	1.00770	.99235
8	1.000114	.999886	50	1.01195	.98820
9	1.000176	.999824	60	1.01691	.98338
10	1.000253	.999747	70	1.02256	.97794
11	1.000345	.999655	80	1.02887	.97194
12	1.000451	.999549	90	1.03567	.96556
13	1.000570	.999430	100	1.04312	.95865

TABLE III.

Pressure of Aqueous Vapor in Mms. of Mercury (G., 130).

t° C.	Mms.	t° C.	Mms.	t° C.	Mms.	t° C.	Atmos.
-10	2.08	16	13.54	90	525.39	100	1.0
- 9	2.26	17	14.42	95	633.69	110	1.4
- 8	2.46	18	15.36	99	733.21	120	1.96
- 7	2.67	19	16.35	99.1	735.85	130	2.67
- 6	2.89	20	17.39	99.2	738.50	140	3.57
- 5	3.13	21	18.50	99.3	741.16	150	4.7
- 4	3.39	22	19.66	99.4	743.83	160	6.1
- 3	3.66	23	20.89	99.5	746.50	170	7.8
- 2	3.96	24	22.18	99.6	749.18	180	9.9
- 1	4.27	25	23.55	99.7	751.87	190	12.4
0	4.60	26	24.99	99.8	754.57	200	15.4
1	4.94	27	26.51	99.9	757.28	210	18.8
2	5.30	28	28.10	100	760.00	220	22.9
3	5.69	29	29.78	100.1	762.73	230	27.5
4	6.10	30	31.55	100.2	765.46		
5	6.53	35	41.83	100.3	768.20		
6	7.00	40	54.91	100.4	771.95		
7	7.49	45	71.39	100.5	773.71		
8	8.02	50	91.98	100.6	776.48		
9	8.57	55	117.48	100.7	779.26		
10	9.17	60	148.79	100.8	782.04		
11	9.79	65	186.94	100.9	784.83		
12	10.46	70	233.08	101	787.59		
13	11.16	75	288.50	105	906.41		
14	11.91	80	354.62	110	1075.37		
15	12.70	85	433.00				

TABLE IV.

Specific Resistances in C.G.S. Units at 0° C.¹

Metals.	Spec. Resist.	Temp. Coef. between 0° and 100° C.
Platinum	10,917	0.00367
Gold	2,197	0.00377
Palladium	10,219	0.00354
Silver	1,468	0.00400
Copper	1,561	0.00428
Aluminium 99 %	2,563	0.00423
Iron	9,065	0.00625
Nickel	12,323	0.00622
Tin	13,048	0.00440
Magnesium	4,355	0.00381
Zinc	5,751	0.00406
Cadmium	10,023	0.00419
Lead	20,380	0.00411
Thallium	17,633	0.00398
Alloys.	Spec. Resist.	Temp. Coef. at 15° C.
Platinum-Silver Pt, 33; Ag, 66.	31,582	0.000243
Platinum-Iridium Pt, 80; Ir, 20.	30,896	0.000822
Platinum-Rhodium Pt, 90; Rd, 10.	21,142	0.00143
Gold-Silver Au, 90; Ag, 10.	6,280	0.00124
Aluminium-Silver Al, 94; Ag, 6.	4,641	0.00238
Aluminium-Copper Al, 94; Cu, 6.	2,904	0.00381
Copper-Aluminium Cu, 97; Al, 3.	8,847	0.000897
Manganin Cu, 84; Mn, 12; Ni, 4.	46,678	0.0000
German Silver	29,982	0.000273
Platinoid	41,731	0.00031

¹ Dewar and Fleming, *Phil. Mag.*, Vol. XXXVI., p. 271.

INDEX.

Numbers refer to pages.

- Absorption**, of radiation, 112; two characteristics of, 113.
- Accumulator**, Kelvin's water-dropping, 179.
- Adiabatic lines**, 135.
- Agonic lines**, 325.
- Air thermometer**, constant volume, 39; method of measuring potential of the, 230.
- Alcohol thermometer**, 18.
- Alternators**, 410.
- Amalgam**, 247.
- Ampere**, 334; the, 341.
- Ampère's rule**, 330; stand, 345, 363.
- Andrews**, 76, 85.
- Anions**, 255.
- Arago**, 353; rotations, 379.
- Arc**, electric, 291.
- Armature**, 354; drum, 400; the Gramme, 403.
- Arts**, electrolysis in the, 270.
- Astatic**, pair, Nobili's, 337; mirror galvanometer, 337.
- Athermanous**, 112.
- Atomic heat**, 50.
- Attraction**, and repulsion, 152; due to induction, 173.
- Aurora**, the, 232.
- Ayrton-Mather**, 339.
- Bacon**, 2.
- Balance**, Coulomb's torsion, 161; Kelvin, 349.
- Barlow's wheel**, 347.
- Battery**, Grove's gas, 266; voltaic, 236.
- Bichromate cell**, 246.
- Bidwell**, 314, 321.
- Boiling point**, 15, 69; effect of pressure on, 69.
- Bosanquet**, 363.
- Bottomley's experiment** on regelation, 60.
- Boutigny**, 72.
- Boyle**, 2; thermometer, 19; law, 37; and Charles' laws combined, 38; laws, deduction of, 145, 153.
- Bridges**, Wheatstone's, 279.
- Budde**, 72.
- Bunsen**, 59; cell, 245.
- Caloric**, 2.
- Calorie**, 42.
- Calorimetry**, 42.
- Capacity**, definition of, 201; of insulated sphere, 201; of two concentric spheres, 204; of two parallel plates, 205.
- Carbon**, filament, 292; specific heat of, 48.
- Carnot's cycle**, 136; reversibility of engine, 139.
- Cathode**, 255; rays, 394.

- Cations**, 255.
Cautery, electric, 290.
Cavendish, 218.
Cell, bichromate, 246; Bunsen, 245; chemical action in Daniell, 242; Clark standard, 251; copper oxide, 249; Daniell, 241, 253; data relating to, 252; gravity, 243; Leclanché, 248; Planté's storage, 267; reversibility of Daniell, 262; silver chloride, 250; effect of heat on, 253.
Cells, in multiple series, 283; in parallel, 282; in series, 280.
Celsius, 16.
Change of volume during fusion, 56.
Charge, distribution of, 159; external, 158; redistribution of, 160; residual of Leyden jar, 207.
Charged sphere, force outside of, 165.
Charges, equal and of opposite sign, 156.
Charles, law of, 20.
Chemical action in relation to energy, 244.
Choking coils, 414, 416.
Circular coil, intensity of field at centre of, 333.
Clark standard cell, 252.
Clausius, 141, 147, 268.
Coefficient, of elasticity of a gas, 131; of thermal conductivity, 94.
Coefficients, of dilatation and pressure, table of, 37; of length and volume, relation between, 26.
Coil, the induction, 388.
Coils, choking, 414, 416.
Cold due to evaporation, 76.
Comparator, interferential, 29.
Concentric spheres, capacity of two, 204.
Condensation, effect of electrification on, 225.
Condensers, 202; capacity of, 202; connected in series, energy of, 211; energy expended in charging, 209.
Conduction, by gases, 98; by liquids, 99; by solids, 91; in wood and crystals, 97.
Conductivities, comparison of thermal and electrical, 95; table of, 96.
Conductivity, coefficient of thermal, 94; electrical, 276.
Conductor, equilibrium of a, 191.
Conductors and insulators, 154; distinction between, 214.
Consequent poles, 312.
Constant, Verdet's, 431.
Convection, by hydrogen, 102; currents, 350; electric, of heat, 302; electrolytic, 269; in gases, 100; in liquids, 99.
Cooling, Newton's law of, 124.
Copper, oxide cell, 249; voltameter, 262.
Cores, 354.
Coulomb, 160; the, 341.
Coulomb's law, 168; torsion balance, 161.
Counter E.M.F. in a circuit, 288.
Critical temperature, 85.
Crookes tubes, 392.
Cryolite, 271.
Cubical dilatation of solids, 23.

- Cuneus, 206.
- Current, electromagnetic unit of, 334; heating effect of, 290; intensity of, 233; lag of, behind E.M.F., 411; magnetic relations of, 329; through a circular conductor, magnetic field about, 332.
- Currents, convection, 350; polyphase, 417; steady, 233; theory of production of, 243; value of alternating, 412.
- Curves of magnetization, 359.
- Cycle, Carnot's, 136.
- D'Alibard, 224.
- Daniell cell, 224; chemical action in, 242.
- D'Arsonval galvanometer, 338, 349; Ayrton-Mather form of, 339.
- Davy, experiment, 5, 291, 353.
- Declination, magnetic, 325; variations in, 326.
- Definition of capacity, 201.
- Definitions, 118.
- Deflections, magnetic forces by method of, 317.
- De la Tour, 84.
- Depolarization by chemical means, 241.
- Depretz, 56.
- Dew, 80; point, 79.
- Dewar, 86, 297, 314.
- Diathermancy, of gases, 115; of liquids, 114.
- Diathermanous, 112.
- Dielectric, effect on electric intensity, 221; on the forces between the plates, 221.
- Dielectric polarization, 213.
- Dielectrics, 155.
- Dilatation, of gases, 35; of liquids, 30; of solids, the cubical, 23; of water, 33.
- Dip, magnetic, 327.
- Dipping needle, 327.
- Discharge, with impulsive rush, 228; with steady strain, 227.
- Discharges, in high vacua, 390; oscillatory, 422.
- Discovery, Faraday's, 372.
- Displacement, electric, 215.
- Distribution of charge, 159.
- Dry pile, 234.
- Dulong and Petit, 50, 124; experiments, table of, 47.
- Dynamo, and motor, reactions in field of, 403; compound-wound, 401; ideal simple, 397; over-compounded, 402.
- Earth a magnet, 323.
- Ebullition, 65, 67.
- Effect, Hall, 351; Peltier, 299; Thomson, 301.
- Efficiency, electrical, of a motor, 408; of transmission, 409.
- Electric, arc, 291; cauterly, 290; displacement, 215; energy, conversion of into heat, 286; field and lines of force, 155; heating, 290; intensity, effect of the dielectric on, 168; pressure, 238; strain, 211; transfer in closed circuits, 215; welding, 291.
- Electrical, efficiency of a motor, 408; potential, 188; resonance, 424; units, 341.
- Electricity, and electrification, 150; thermal, 293; three divisions of, 151.

- Electrification**, by influence, 171; effect of, on condensation, 225; two kinds of, 153; with like charges by influence, 173.
- Electro-chemical equivalents**, 259.
- Electrode**, positive, 236; negative, 236.
- Electrodes**, 255.
- Electrodynamics**, 343.
- Electrodynamometer**, 347, 413.
- Electrolysis**, 255; in the arts, 270; quantitative laws of, 258; of copper sulphate, 257; of lead acetate, 258; of sodium sulphate, 257; of water, 256; theory of, 268; with and without polarization, 265.
- Electrolyte**, 237.
- Electrolytes**, 255.
- Electrolytic cell**, polarization of, 264.
- Electromagnetic**, rotations, 346; systems, motion in, 369; theory of light, Maxwell's, 426; waves, 425.
- Electromagnets**, 353.
- Electrometer**, 194; attracted disk, 195; theory and use of, 195; quadrant, 197.
- Electromotive force**, 238; and potential difference, 237; counter, in motor, 406; direction and value of induced, 374; law of, 375, 398.
- Electrophorus**, 176.
- Electroscope**, 157; gold-leaf, 158.
- Electrostatics**, second law of, 163.
- Element**, voltaic, 236.
- Energy**, chemical action in relation to, 244; expended in charging condenser, 209; heat a form of, 1; in a current, division of the, 289; lost in dividing a charge, 209; of similar condensers in parallel, 210; of successive charges, 178; stored in magnetic field, 386; total molecular, 147.
- Equal charges of opposite sign**, 156.
- Equation**, Helmholtz's, 385.
- Equator**, magnetic, 327.
- Equilibrium of a conductor**, 191.
- Equipotential surfaces**, 189.
- Equivalents**, electro-chemical, 259.
- Erman**, 57.
- Euler**, 362.
- Evaporation**, 65; cold due to, 76; in a closed space, 66.
- Ewing's theory of magnetism**, 323.
- Exchanges**, Prevost's theory of, 116.
- Expansion**, 11; linear, 25; of liquids and gases, 12.
- Expression for force in terms of potential**, 190.
- External charge**, 158.
- Extra current**, 382.
- Farad**, 341.
- Faraday**, 83, 155, 159, 218, 258, 350, 362, 426; discovery, 372; experiment, 175; ice-pail experiment, 175; magneto-optic rotations, 430; ring, 377.
- Fahrenheit**, 56.
- Field**, electric, 155; magnet, 401; rotatory, 418.
- Filament**, the carbon, 292.
- Fizeau**, 24.

- Fleming, 297.
 Forbes, 109, 114.
 Force, electromotive, 238; expression for, in terms of potential, 190; magnetomotive, 366; near a charged plane conductor, 168; outside a charged sphere, 165; very near a charged sphere, 167; within a helix, 366.
 Franklin, 208, 224.
 Fraunhofer lines, 110.
 Fusing point, 54.
 Fusion, 54; change of volume during, 56; latent heat of, 61.
 Galileo, 19.
 Galvanometer, 335; astatic mirror, 337; d'Arsonval, 338; potential, 339; tangent, 335.
 Gas, and vapor, distinction between, 86; battery, 266; coefficient of elasticity of, 131; volume proportional to absolute temperature, 38.
 Gases, dilatation of, 35; law of, 146; liquefaction of, 83; specific heat of, 52; theory of the pressure of, 143.
 Gay-Lussac, 56; law of, 146.
 Geissler tubes, 391; striæ in, 391.
 Gilbert, 155; electroscope, 157.
 Gramme ring, 403.
 Gravity cell, 243.
 Gray, 155.
 Grove's gas battery, 266.
 Growth of current in inductive circuits, 384.
 Hall effect, 351.
 Heat absorbed in solution, 63; effect of on resistance, 276; equivalent of a current, 287; laws of development of, 287; modes of transmission, 90; polarization of, 109.
 Helix, force within, 366.
 Helmholtz, 252; equation, 385.
 Henry, 215, 342, 382, 425; the, 342.
 Hertz, 394, 426; researches, 428.
 Holtz influence machine, 180.
 Hooke, 14.
 Hopkinson, 212.
 Horse-shoe magnet, 353.
 Humidity, relative, 78.
 Hydrogen, convection in, 102; mean square of the velocity of, 145.
 Hygrometer, Regnault's, 80.
 Hysteresis, 213, 360.
 Ice-pail experiment, Faraday's, 175.
 Inclination, magnetic, 327.
 Induced, and inducing charges, relation between, 174; electromotive force, 372.
 Inductance, 383.
 Induction, attraction due to, 173; by magnets, 373; coefficient of mutual, 381; coefficient of self, 383; coil, 388; magnetic, and magnetic force, 359; motor, 420; self, 382.
 Inductive, capacity, specific, 217; circuits, growth of current in, 384; system, 378.
 Influence, charging by, 172; electrification by, 171; electrification with like charges by, 173; machine, the Holtz, 180.

- Ingenhausz**, experiment of, 92.
Instability, condition of, 55.
Insulators and conductors, 154;
 distinction between, 214.
**Intensity of field at centre of
 circular coil**, 333.
Inverse squares, law of, 107, 162;
 proof of law, 164.
Ions, 237.
Iron, effect of introducing, 353;
 hysteresis in, 360.
Isoclinic lines, 327.
Isodynamic lines, 327.
Isogonic lines, 325.
Isothermal lines, 133.

J and R, relation between, 130.
Jolly, 39.
Joule, 341, 362.
Joule's experiment, 127.

Kelvin, 141, 194, 198; balances,
 349; water-dropping apparatus,
 179.
Kerr, 212.
Kohlrusch, 212.

Lag, of current behind E.M.F.,
 411; of induction behind mag-
 netizing force, 361.
Langley, 7, 110, 111.
Latent heat, of fusion, 61; of
 vaporization, 74.
Law, Lenz's, 379, 380; of devel-
 opment of heat, 287; of inverse
 squares, 107; of magnetic cir-
 cuit, 368; of magnetic force,
 306, 316; of resistance, 275;
 Ohm's, 273.
Laws of Boyle and Charles com-
 bined, 38.

Leclanché cell, 248; chemical
 action in, 249.
Lemström, 232.
Lenard, 395.
Lenz's law, 379, 380.
Leslie's experiment, 117.
Leyden jar, 206, 211, 228, 370;
 residual charge of, 207; seat of
 the charge in, 208.
Light, Maxwell's electromagnetic
 theory of, 426.
Lightning, an electrical phenom-
 enon, 224; flashes, 226; pro-
 tectors, 229.
Linear expansion, 25; measure-
 ment of, 28.
Lines, isoclinic, 327; isodynamic,
 327; isogonic, 325; isothermal,
 133; of force and electric field,
 155.
Liquefaction of gases, 82; of oxy-
 gen and nitrogen, 87.
Liquid and gaseous states, con-
 tinuity of, 84.
Liquids, convection in, 99; dia-
 thermancy of, 114; dilatation of,
 30.
Local action and amalgamation,
 247.

Machine, Holtz influence, 180;
 Toepler, 182; Wimshurst, 184.
Magne-crystallic action, 358.
Magnetic, circuit, law of, 362, 368;
 equator, 327; field, 308; field
 about a wire, 331; field about
 current through circular con-
 ductor, 332; field, energy stored
 in, 386; fields about parallel cur-
 rents, 343; figures, 310; force
 due to straight current, 365;

force, first law of, 306; second law of, 317; forces by method of deflections, 318; by method of oscillations, 319; inclination, 326; induction, 307; induction and magnetic force, 359; moment, 316; permeability, 355; shielding, 311; substances, 311; susceptibility, 355.

Magnetic relations, Ampère's rule, 330; Moreland's rule, 330; Maxwell's rule, 330; of a current, 329.

Magnetism, and mechanical stress, 320; effects of heat on, 313; Ewing's theory of, 323; molecular, 322.

Magnetization, by electric discharges, 370; curves of, 359.

Magneto-optic rotations, 430; explanation of, 432.

Magnets, 305; artificial, 306; horseshoe, 354; induction by, 313; permanent and temporary, 308.

Mascart, 230.

Material bodies, heat in, 2.

Maxwell, 155, 214, 350, 362, 426.

Maxwell's rule, 330.

McAdie, 231.

Mechanical stress and magnetism, 320.

Melloni, 108, 112, 114.

Melting point, influence of pressure on, 58.

Mendenhall, 232.

Mercury, 13, 346, 347.

Metals and liquids, thermo-electromotive force between, 302.

Michelson, 28, 427.

Molecular hypothesis, 142.

Moreland's rule, 330.

Morley's comparator, 29.

Motor, counter E.M.F. in, 406; direction of rotation as a, 405; electrical efficiency of, 408; induction, 420; work done by, 407.

Motors and dynamos, 397.

Negative, electricity, 154; electrode, 236.

Neutral temperature, 294.

Newton, 114.

Newton's law of cooling, 124.

Nobili's astatic pair, 337.

Oersted's discovery, 329.

Ohm, 274, 341.

Ohm's law, 273.

Oscillation, period of, 423.

Oscillations, comparison of pole-strengths by, 320; magnetic forces by method of, 318.

Oscillator, Hertz's, 428.

Oscillatory discharges, 422.

Osmotic pressure, 243.

Oxygen and nitrogen, liquefaction of, 87.

Parallel, and oblique currents, 345; plates, capacity of two, 205.

Paramagnetic and diamagnetic substances compared, 356.

Peltier effect, 299; experiment to show, 300.

Person, 55.

Petit and Dulong, experiment, 47, 50, 124.

Phosphorus, dilatation of, 58.

Pile, the dry, 234; Volta's, 233.

Plane, conductor, force near a charged, 168.

- Planté's storage cell, 267.
- Polarization**, 240; dielectric, 213; of electrolytic cell, 264; of heat, 109.
- Pole**, unit, 315.
- Poles**, consequent, 312; strength of, 315.
- Pole-strengths** by oscillations, comparison of, 320.
- Polyphase currents**, 417.
- Positive**, electricity, 154; electrode, 236.
- Potential**, difference of, 189; difference of, and E.M.F., 239; electrical, definition of, 188; expression of force in terms of, 190; high, of thunder clouds, 224; loss of, proportional to resistance, 278; of the air, method of measuring, 230; of a sphere, 193; results of observation, 231.
- Practical electrical units**, 341.
- Pressure**, influence of on boiling point, 69; influence of on melting point, 58; of a gas, theory of, 143.
- Preston**, 47.
- Prevost's theory of exchanges**, 116; extension of, 120.
- Primary cells**, 233.
- Production of a current**, theory of, 243.
- Quadrant electrometer**, 197; used heterostatically, 199; used idio-statically, 199.
- Quantity**, unit, of electricity, 164; of heat, 42.
- Radiant energy**, heat the measure of, 110.
- Radiant heat**, 6; and light identical, 7; refraction of, 108.
- Radiation**, 6; appliances for the study of, 104; invisible, reflected like light, 105.
- Ratio of the two specific heats**, 148.
- Rayleigh**, 225, 390, 431.
- Rays**, cathode, 394; Röntgen, 394.
- Reactions in field of dynamo and motor**, 403.
- Redistribution of charge**, 160.
- Refraction of radiant heat**, 108.
- Regelation**, 59.
- Regnault**, 33, 37; conclusions respecting specific heat of gases, 52; hygrometer, 80.
- Relation between induced and inducing charges**, 174; between μ and κ , 355.
- Reluctance**, 367.
- Remanence and coercive force**, 362.
- Researches**, Hertz's, 428.
- Residual**, charge of Leyden jar, 207; magnetism, 353.
- Resinous electricity**, 154.
- Resistance**, 274; effect of heat on, 276; laws of, 275; specific, 275; variation of internal, with current, 283.
- Resonance**, electrical, 424.
- Resonator**, Hertz's, 429.
- Reversibility of Daniell cell**, 262.
- Richmann**, 224.
- Ring**, Faraday's, 377.
- Röntgen**, 394.
- Rogers' comparator**, 28.
- Ross**, 324.
- Rotation**, direction of as a motor,

- 405; Faraday's magneto-optic, 430, 432; in a magnetic field, 363.
- Rotations, Arago's, 379.
- Rotatory field, 418.
- Rowland, 50, 363; experiments, 129, 350.
- Rumford's experiment, 3.
- Safety fuses, 290.
- Scale, centigrade, 16; Fahrenheit's, 16; Réaumur's, 16.
- Schwatke, 324.
- Second law of electrostatics, 163.
- Seebeck, 293, 299.
- Self-Induction, 382.
- Siemens, 212.
- Silver, chloride cell, 250; voltameter, 260.
- Similar condensers in parallel, 210.
- Simple, bodies, atomic heat of, 50; voltaic element, 235, 237.
- Solenoids, 352; effect of introducing iron in, 353.
- Solids, conduction by, 91.
- Solution, heat absorbed in, 63; tension, 243.
- Specific heat, at constant volume, 147; by method of mixtures, 44; of carbon, 48; of gases, 51; of water, 49; ratio of the two, 148; table of Dulong and Petit, 47; variation of, with temperature, 47.
- Speed, 407.
- Sphere, capacity of an insulated, 201; capacity of two concentric, 204; force outside a charged, 165; force very near a charged, 167; potential of, 193.
- Spheroidal state, 65, 72.
- Steady strain, discharge with, 227.
- Stewart, 114, 122.
- Strength of pole, 315.
- Sublimation, 65, 73.
- Successive charges, energy of, 178.
- Surface density, 159.
- Surfaces, equipotential, 189.
- System, the inductive, 378.
- Tait, 96.
- Telephone, the, 395.
- Temperature, definition of, 9; neutral, 294.
- Theory, of electrolysis, 268; of magnetism, 322.
- Thermal, capacity, 45; electricity, 293; E.M.F., variation with temperature, 295.
- Thermodynamics, first law of, 126; second law of, 141.
- Thermo-electric, diagram, 296; series, 298.
- Thermo E.M.F., between metals and liquids, 302; in diagram, 297.
- Thermometer, air, 19; alcohol, 18; Boyle's, 19; constant volume air, 39; fixed points on, 14; Galileo's, 19; mercurial, 13; scales, 15, 16.
- Thermopile, 105, 298.
- Thomson, 58, 350, 392; effect, 301.
- Thunder clouds, high potential, 224.
- Toepler machine, 182.
- Torque, 407.
- Torsion balance, 161.
- Total molecular energy, 147.
- Transfer, electric, in closed circuits, 215.

Transformers, 415.

Transmission, efficiency of electric, 409; of heat, modes of, 90.

Trowbridge, 429.

Tyndall, 115, 119, 358.

Unit, capacity, 341; electromagnetic, 340; magnetic pole, 314; of current, the electromagnetic, 334; of electromagnetic quantity, 340; of electrostatic quantity, 164; potential difference, 340; practical electrical, 341; quantity of heat, 42; resistance, 341; strength of current, 340.

Vacua, discharges in high, 392; discharges in partial, 390.

Value, of alternating current, 412.

Vaporization, 65; latent heat of, 74.

Variation of internal resistance with current, 283.

Velocity, of hydrogen, mean square of, 145.

Verdet's constant, 431.

Villari, critical point, 321; reversal, 321.

Virtual volts and amperes, 413.

Vitreous electricity, 154.

Volt, 341; virtual, 413.

Volta, 176; pile, 233.

Voltaic cells, effect of heat on, 253; element, simple, 235.

Voltmeter, copper, 262; silver, 260.

Volume of gas proportional to temperature, 38.

Water, electrolysis of, 256; specific heat of, 49.

Watt, 342.

Wattmeters, 414.

Waves, electromagnetic, 425.

Weber, 322.

Wells' explanation of dew, 80.

Wheatstone's bridge, 279.

Wiedemann, 321.

Wimshurst machine, 184.

Wollaston's cyclophorus, 77.

Zero, absolute, 20; change of, 17.

Walker's Anatomy, Physiology, and Hygiene.

New Edition, revised and enlarged. By JEROME WALKER, M.D.
12mo, cloth, 495 pages. Price, \$1.20.

THIS is a thorough and careful revision by the author of the book which has for so long been a standard in secondary schools.

The principle which has been kept consistently in mind in the revision is that physiology and anatomy are of little real value unless they lead to a knowledge of hygiene. Primarily, then, the book is practical, and aims to point out constantly the every-day applications of the principles of physiology. The subjects of alcohol and narcotics have been treated in this edition according to the most recent investigations, and so as to comply with the requirements of the laws in various states. The statements throughout are only such as will be accepted as sound by physicians and scientific men. All important points have been brought out fully and distinctly, and without such dry or verbose explanations as render them difficult to remember. Many of the chapters have been revised by specialists in the subjects of which they treat. The result of the revision as a whole is to produce a book which eminent physicians endorse as fair and truthful, which teachers accept as giving constant satisfaction in the class room, and pupils welcome from the practical character of its instruction.

New material has been added to the text, most of it on the subjects of cell life, food, and the nervous system. Thirty-five new illustrations and diagrams are introduced. The chapter on Emergencies has been re-written, with a view to making it thoroughly practical. It contains sound, sensible advice for the treatment of all sorts of injuries and is of undeniable value to the general reader as well as to the pupil.

A great deal of valuable matter has been collected for the appendix and foot-notes, all of which, as is the case with all the new points in the text itself, is thoroughly in accord with the latest research on the various subjects touched upon.

Electrical Measurements.

By Professor HENRY S. CARHART and Asst. Professor G. W. PATTERSON, University of Michigan. 12mo, cloth, 344 pages. Price, \$2.00.

IN this book are presented a graded series of experiments for the use of classes in electrical measurements. Quantitative experiments only have been introduced, and these have been selected with the object of illustrating general methods rather than applications to specific departments of technical work.

The several chapters have been introduced in what the authors believed to be the order of their difficulty. Explanations or demonstrations of the principles involved have been given, as well as descriptions of the methods employed.

The Electrical Engineer, New York: We can recommend this book very highly to all teachers in elementary laboratory work.

The Electrical Journal, Chicago: This is a very well-arranged text-book and an excellent laboratory guide.

Exercises in Physical Measurement.

By Professors L. W. AUSTIN, University of Wisconsin, and C. B. THWING, Syracuse University. 12mo, cloth, 208 pages. Price, \$1.50.

THIS book puts in compact and convenient form such directions for work and such data as are required by a student in his first year in the physical laboratory.

The exercises in Part I. are essentially those included in the *Practicum* of the best German universities. They are exclusively quantitative, and the apparatus required is inexpensive.

Part II. contains such suggestions regarding computations and important physical manipulations as will make unnecessary the purchase of a second laboratory manual.

Part III. contains in tabular form such data as will be needed by the student in making computations and verifying results.

Professor Sarah F. Whiting, Wellesley College: It comprises very nearly the list of exercises which I have found practical in a first-year college course in Physics. I note that while the directions are brief, skill is shown in seizing the very points which need to be emphasized. The Introduction with Part II. gives a very clear presentation of the essential things in Measurements, and of the treatment of errors.

The Elements of Chemistry.

By Professor PAUL C. FREER, University of Michigan. 12mo, cloth, 294 pages. Price, \$1.00.

IN the preparation of this book an attempt has been made to give prominence to what is *essential* in the science of Chemistry, and to make the pupil familiar with the general aspect of chemical changes, rather than to state as many facts as possible. To this end only a few of the most important elements and compounds have been introduced; and the work, both in the text and in the laboratory appendix, has been made *quantitative*.

Chemical equations have been sparingly used, because they are apt to give the pupils false notions of the processes they attempt to record. Considerable space has been given to physical chemistry, and a constant effort has been made to present chemistry as an exact science.

The apparatus required to perform successfully the experiments suggested will not be found expensive, the most costly being such as will form part of the permanent equipment of a laboratory, and if properly handled will not need to be replaced during a long term of years.

Professor Charles Baskerville, University of North Carolina: It is the most excellent book of the character which has ever come to my notice. It is clear, scientific, and thoroughly up to date.

Elements of Chemical Physics.

By JOSIAH PARSONS COOKE. 8vo, cloth, 751 pages. Price, \$4.50.

THIS volume furnishes a full development of the principles of chemical phenomena. It has been prepared on a strictly inductive method and any student with an elementary knowledge of mathematics can easily follow the course of reasoning.

Chemical Tables.

By STEPHEN P. SHARPLES. 12mo, cloth, 199 pages. Price, \$2.00.

Descriptive Inorganic General Chemistry.

A text-book for colleges, by Professor PAUL C. FREER, University of Michigan. Revised Edition. 8vo, cloth, 559 pages. Price, \$3.00.

IT aims to give a systematic course of Chemistry by stating certain initial principles, and connecting logically all the resultant phenomena. In this way the science of Chemistry appears, not as a series of disconnected facts, but as a harmonious and consistent whole.

The relationship of members of the same family of elements is made conspicuous, and resemblances between the different families are pointed out. The connection between reactions is dwelt upon, and where possible they are referred to certain principles which result from the nature of the component elements.

The frequent use of tables and of comparative summaries lessens the work of memorizing and affords facilities for rapid reference to the usual constants, such as specific gravity, melting and boiling points, etc.

Professor Walter S. Haines, Rush Medical College, Chicago: The work is worthy of the highest praise. The typography is excellent, the arrangement of the subjects admirable, the explanations full and clear, and facts and theories are brought down to the latest date. All things considered, I regard it as the best work on inorganic chemistry for somewhat advanced general students of the science with which I am acquainted.

Principles of Chemical Philosophy.

By JOSIAH PARSONS COOKE, late Professor of Chemistry, Harvard University. Revised Edition. 8vo, cloth, 634 pages.

THE object of this book is to present the philosophy of chemistry in such a form that it can be made with profit the subject of college recitations. Part I. of the book contains a statement of the general laws and theories of chemistry, together with so much of the principles of molecular physics as are constantly applied to chemical investigations. Part II. presents the scheme of the chemical elements, and is to be studied in connection with experimental lectures or laboratory work.

