

UC-NRLF

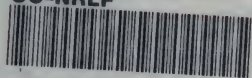

QB 100 288

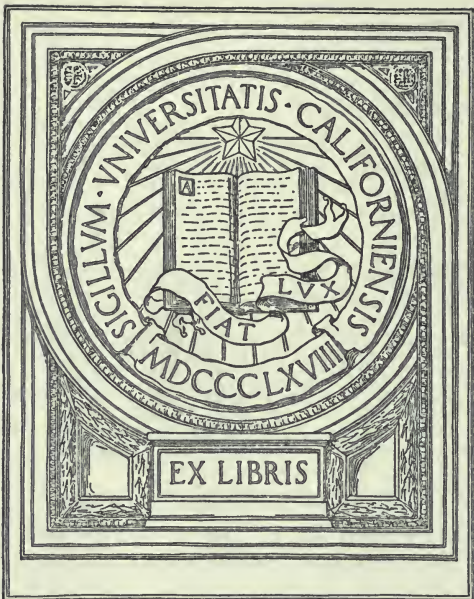

EX LIBRIS



Digitized by the Internet Archive
in 2007 with funding from
Microsoft Corporation

THE ELEMENTS OF
ANALYTIC GEOMETRY

BY

PERCEY F. SMITH, PH.D.

PROFESSOR OF MATHEMATICS IN THE SHEFFIELD SCIENTIFIC SCHOOL
YALE UNIVERSITY

AND

ARTHUR SULLIVAN GALE, PH.D.

FAYERWEATHER PROFESSOR OF MATHEMATICS IN
THE UNIVERSITY OF ROCHESTER



GINN & COMPANY

BOSTON · NEW YORK · CHICAGO · LONDON

Office
562

GENERAL

COPYRIGHT, 1904, BY
ARTHUR SULLIVAN GALE

ALL RIGHTS RESERVED

99.1

The Athenzum Press
GINN & COMPANY • PRO-
PRIETORS • BOSTON • U.S.A.

PREFACE

In preparing this volume the authors have endeavored to write a drill book for beginners which presents the elements of the subject in a manner conforming with modern ideas. The scope of the book is limited only by the assumption that a knowledge of Algebra through quadratics must suffice for any investigation. This does not mean a treatise on conic sections. In fact, the authors have intentionally avoided giving the book this form. Conic sections naturally appear, but chiefly as illustrative of general analytic methods. A chapter is devoted to their study, but the numerous properties of these curves are developed incidentally as applications of methods of general importance.

The subject-matter is rather more than is necessary for the usual course of sixty exercises. It has been made so intentionally, to permit of choice on the part of the teacher, and also in order to include all topics strictly elementary in the sense defined above. The table of contents will show topics not usually treated. For example, in discussing the nature of the locus of the general equation of the second degree (Chapter XII), invariants are introduced. Again, three chapters are devoted to the simple transformations in the plane. After mastering the entire book, the student is assured of an acquaintance with all that is fundamental in modern Analytic Euclidean Geometry.

Attention is called to the method of treatment. The subject is developed after the Euclidean method of definition and theorem,

without, however, adhering to formal presentation. The advantage is obvious, for the student is made sure of the exact nature of each acquisition. Again, each method is summarized in a rule stated in consecutive steps. This is a gain in clearness. Many illustrative examples are worked out in the text.

Emphasis has everywhere been put upon the analytic side, that is, the student is taught to start from the equation. He is shown how to work with the figure as a guide, but is warned not to use it in any other way. Chapter III may be referred to in this connection.

The same methods have been used uniformly for the plane and for space. In this way the extension to three dimensions is made easy and profitable.

Acknowledgments are due to Dr. W. A. Granville for many helpful suggestions, to Professor E. H. Lockwood for suggestions regarding some of the drawings, and to Mr. L. C. Weeks for assistance in proof reading.

NEW HAVEN, CONNECTICUT
December, 1904

CONTENTS

CHAPTER I

REVIEW OF ALGEBRA AND TRIGONOMETRY

SECTION	PAGE
1. Numbers	1
2. Constants	1
3. The quadratic. Typical form	2
4. Special quadratics	4
5. Cases when the roots of a quadratic are not independent	5
6. Variables	10
7. Variation in sign of a quadratic	10
8. Infinite roots	14
9. Equations in several variables	16
10. Functions of an angle in a right triangle	18
11. Angles in general	18
12. Formulas and theorems from Trigonometry	19
13. Natural values of trigonometric functions	21
14. Rules for signs	22
15. Greek alphabet	22

CHAPTER II

CARTESIAN COÖRDINATES

16. Directed line	23
17. Cartesian coördinates	24
18. Rectangular coördinates	25
19. Angles	28
20. Orthogonal projection	29
21. Lengths	31
22. Inclination and slope	34
23. Point of division	38
24. Areas	42
25. Second theorem of projection	47

CHAPTER III

THE CURVE AND THE EQUATION

SECTION	PAGE
26. Locus of a point satisfying a given condition	51
27. Equation of the locus of a point satisfying a given condition	51
28. First fundamental problem	53
29. General equations of the straight line and circle	57
30. Locus of an equation	59
31. Second fundamental problem	60
32. Principle of comparison	62
33. Third fundamental problem. Discussion of an equation	67
34. Symmetry	72
35. Further discussion	73
36. Directions for discussing an equation	74
37. Points of intersection	76
38. Transcendental curves	79
39. Graphical representation in general	83

CHAPTER IV

THE STRAIGHT LINE AND THE GENERAL EQUATION OF THE FIRST DEGREE

40. Introduction	85
41. The degree of the equation of a straight line	85
42. The general equation of the first degree, $Ax + By + C = 0$	86
43. Geometric interpretation of the solution of two equations of the first degree	89
44. Straight lines determined by two conditions	92
45. The equation of the straight line in terms of its slope and the coördinates of any point on the line	95
46. The equation of the straight line in terms of its intercepts	96
47. The equation of the straight line passing through two given points	97
48. The normal form of the equation of the straight line	101
49. The distance from a line to a point	105
50. The angle which a line makes with a second line	109
51. Systems of straight lines	113
52. The system of lines parallel to a given line	116
53. The system of lines perpendicular to a given line	117
54. The system of lines passing through the intersection of two given lines	119
55. The parametric equations of the straight line	123

CHAPTER V

THE CIRCLE AND THE EQUATION $x^2 + y^2 + Dx + Ey + F = 0$

SECTION	PAGE
56. The general equation of the circle	130
57. Circles determined by three conditions	132
58. Systems of circles	136
59. The length of the tangent	144

CHAPTER VI

POLAR COÖRDINATES

60. Polar coördinates	149
61. Locus of an equation	150
62. Transformation from rectangular to polar coördinates	154
63. Applications	156
64. Equation of a locus	157

CHAPTER VII

TRANSFORMATION OF COÖRDINATES

65. Introduction	160
66. Translation of the axes	160
67. Rotation of the axes	162
68. General transformation of coördinates	163
69. Classification of loci	164
70. Simplification of equations by transformation of coördinates	165
71. Application to equations of the first and second degrees	168

CHAPTER VIII

CONIC SECTIONS AND EQUATIONS OF THE SECOND DEGREE

72. Equation in polar coördinates	173
73. Transformation to rectangular coördinates	178
74. Simplification and discussion of the equation in rectangular coördinates. The parabola, $e = 1$	178
75. Simplification and discussion of the equation in rectangular coördinates. Central conics, $e \geq 1$	182
76. Conjugate hyperbolas and asymptotes	189
77. The equilateral hyperbola referred to its asymptotes	191

SECTION	PAGE
78. Focal property of central conics	192
79. Mechanical construction of conics	192
80. Types of loci of equations of the second degree	194
81. Construction of the locus of an equation of the second degree	197
82. Systems of conics	200

CHAPTER IX

TANGENTS AND NORMALS

83. The slope of the tangent	207
84. Equations of tangent and normal	210
85. Equations of tangents and normals to the conic sections	212
86. Tangents to a curve from a point not on the curve	215
87. Properties of tangents and normals to conics	217
88. Tangent to a curve at the origin	221
89. Second method of finding the equation of a tangent	223

CHAPTER X

RELATIONS BETWEEN A LINE AND A CONIC. APPLICATIONS OF THE THEORY OF QUADRATICS

90. Relative positions of a line and conic	226
91. Relative positions of lines of a system and a conic, and of a line and conics of a system	228
92. Tangents to a conic	230
93. Tangent in terms of its slope	233
94. The equation in ρ	235
95. Tangents	237
96. Asymptotic directions and asymptotes	238
97. Centers	240
98. Diameters	241
99. Conjugate diameters of central conics	244

CHAPTER XI

LOCI. PARAMETRIC EQUATIONS

100. Introduction	248
101. Loci defined by a construction and a given curve	249
102. Parametric equations of a curve	253
103. Loci defined by the points of intersection of systems of curves	259

CHAPTER XII

THE GENERAL EQUATION OF THE SECOND DEGREE

SECTION	PAGE
104. Introduction	264
105. Condition for a degenerate conic	264
106. Degenerate conics of a system	267
107. Invariants under a rotation of the axes	269
108. Invariants under a translation of the axes	273
109. Nature of the locus of an equation of the second degree	275
110. Equal conics	278
111. Conics determined by five conditions	279

CHAPTER XIII

EUCLIDEAN TRANSFORMATIONS WITH AN APPLICATION TO SIMILAR CONICS

112. Introduction	281
113. Equal figures	281
114. Translations	282
115. Rotations	282
116. Displacements	284
117. The reflection in a line	287
118. Symmetry transformations	287
119. Congruent and symmetrical conics	291
120. Homothetic transformations	291
121. Similitude transformations	292
122. Similar conics	293

CHAPTER XIV

INVERSION

123. Definition	297
124. Equations of an inversion	297
125. Inversion of conic sections	299
126. Angle formed by two circles	303
127. Angles invariant under inversion	304
128. Inversion of systems of straight lines	306
129. Inversion of a system of concentric circles	307
130. Orthogonal systems of circles	308

CHAPTER XXII

QUADRIC SURFACES AND EQUATIONS OF THE SECOND DEGREE
IN THREE VARIABLES

SECTION	PAGE
176. Quadric surfaces	397
177. Simplification of the general equation of the second degree in three variables	398
178. The ellipsoid $\frac{x^2}{a^2} + \frac{y^2}{b^2} + \frac{z^2}{c^2} = 1$	400
179. The hyperboloid of one sheet $\frac{x^2}{a^2} + \frac{y^2}{b^2} - \frac{z^2}{c^2} = 1$	401
180. The hyperboloid of two sheets $\frac{x^2}{a^2} - \frac{y^2}{b^2} - \frac{z^2}{c^2} = 1$	402
181. The elliptic paraboloid $\frac{x^2}{a^2} + \frac{y^2}{b^2} = 2cz$	405
182. The hyperbolic paraboloid $\frac{x^2}{a^2} - \frac{y^2}{b^2} = 2cz$	406
183. Rectilinear generators	408

CHAPTER XXIII

RELATIONS BETWEEN A LINE AND QUADRIC. APPLICATIONS OF THE
THEORY OF QUADRATICS

184. The equation in ρ . Relative positions of a line and quadric	410
185. Tangent planes	411
186. Polar planes	412
187. Circumscribed cones	412
188. Asymptotic directions and cones	415
189. Centers	419
190. Diametral planes	419
INDEX	423



ANALYTIC GEOMETRY

CHAPTER I

REVIEW OF ALGEBRA AND TRIGONOMETRY

1. Numbers. The numbers arising in carrying out the operations of Algebra are of two kinds, *real* and *imaginary*.

A *real number* is a number whose square is a *positive* number. Zero also is a real number.

A *pure imaginary number* is a number whose square is a *negative* number. Every such number reduces to the square root of a negative number, and hence has the form $b\sqrt{-1}$, where b is a real number, and $(\sqrt{-1})^2 = -1$.

An *imaginary* or *complex number* is a number which may be written in the form $a + b\sqrt{-1}$, where a and b are real numbers, and b is not zero. Evidently the square of an imaginary number is in general also an imaginary number, since

$$(a + b\sqrt{-1})^2 = a^2 - b^2 + 2ab\sqrt{-1},$$

which is imaginary if a is not equal to zero.

2. Constants. A quantity whose value remains unchanged is called a *constant*.

Numerical or *absolute constants* retain the same values in all problems, as 2, -3, $\sqrt{7}$, π , etc.

Arbitrary constants, or *parameters*, are constants to which any one of an unlimited set of numerical values may be assigned, and these assigned values are retained throughout the investigation.

Arbitrary constants are denoted by letters, usually by letters from the first part of the alphabet. In order to increase the number of symbols at our

disposal, it is convenient to use *primes (accents)* or *subscripts* or both. For example:

Using primes,

a' (read "a prime or a first"), a'' (read "a double prime or a second"), a''' (read "a third"), are all different constants.

Using subscripts,

b_1 (read "b one"), b_2 (read "b two"), are different constants.

Using both,

c_1' (read "c one prime"), c_3'' (read "c three double prime"), are different constants.

3. The quadratic. Typical form. Any quadratic equation may by transposing and collecting the terms be written in the Typical Form

$$(1) \quad Ax^2 + Bx + C = 0,$$

in which the *unknown* is denoted by x . The coefficients A , B , C are arbitrary constants, and may have any values whatever, except that A cannot equal zero, since in that case the equation would be no longer of the second degree. C is called the **constant term**.

The left-hand member

$$(2) \quad Ax^2 + Bx + C$$

is called a **quadratic**, and any quadratic may be written in this Typical Form, in which the letter x represents the unknown. The quantity $B^2 - 4AC$ is called the **discriminant** of either (1) or (2), and is denoted by Δ .

That is, the discriminant Δ of a quadratic or quadratic equation in the Typical Form is equal to the square of the coefficient of the first power of the unknown diminished by four times the product of the coefficient of the second power of the unknown by the constant term.

The roots of a quadratic are those numbers which make the quadratic equal to zero when substituted for the unknown.

The roots of the quadratic (2) are also said to be roots of the quadratic equation (1). A root of a quadratic equation is said to **satisfy** that equation.

In Algebra it is shown that (2) or (1) has two roots, x_1 and x_2 , obtained by solving (1), namely,

$$(3) \quad \begin{cases} x_1 = -\frac{B}{2A} + \frac{1}{2A} \sqrt{B^2 - 4AC}, \\ x_2 = -\frac{B}{2A} - \frac{1}{2A} \sqrt{B^2 - 4AC}. \end{cases}$$

Adding these values, we have

$$(4) \quad x_1 + x_2 = -\frac{B}{A}.$$

Multiplying gives

$$(5) \quad x_1 x_2 = \frac{C}{A}.$$

Hence

Theorem I. *The sum of the roots of a quadratic is equal to the coefficient of the first power of the unknown with its sign changed divided by the coefficient of the second power.*

The product of the roots equals the constant term divided by the coefficient of the second power.

The quadratic (2) may be written in the form

$$(6) \quad Ax^2 + Bx + C \equiv^* A(x - x_1)(x - x_2),$$

as may be readily shown by multiplying out the right-hand member and substituting from (4) and (5).

For example, since the roots of $3x^2 - 4x + 1 = 0$ are 1 and $\frac{1}{3}$, we have identically $3x^2 - 4x + 1 \equiv 3(x - 1)(x - \frac{1}{3})$.

The character of the roots x_1 and x_2 as *numbers* (§ 1) when the coefficients A, B, C are real numbers evidently depends entirely upon the discriminant. This dependence is stated in

Theorem II. *If the coefficients of a quadratic are real numbers, and if the discriminant be denoted by Δ , then*

when Δ is positive the roots are real and unequal;

when Δ is zero the roots are real and equal;

when Δ is negative the roots are imaginary.

* The sign \equiv is read "is identical with," and means that the two expressions connected by this sign differ only in form.

In the three cases distinguished by Theorem II the quadratic may be written in three forms in which only *real numbers* appear. These are

$$(7) \begin{cases} Ax^2 + Bx + C \equiv A(x - x_1)(x - x_2), \text{ from (6), if } \Delta \text{ is positive;} \\ Ax^2 + Bx + C \equiv A(x - x_1)^2, \text{ from (6), if } \Delta \text{ is zero;} \\ Ax^2 + Bx + C \equiv A \left[\left(x + \frac{B}{2A} \right)^2 + \frac{4AC - B^2}{4A^2} \right], \text{ if } \Delta \text{ is negative.} \end{cases}$$

The last identity is proved thus:

$$\begin{aligned} Ax^2 + Bx + C &\equiv A \left(x^2 + \frac{B}{A}x + \frac{C}{A} \right) \\ &\equiv A \left(x^2 + \frac{B}{A}x + \frac{B^2}{4A^2} + \frac{C}{A} - \frac{B^2}{4A^2} \right), \end{aligned}$$

adding and subtracting $\frac{B^2}{4A^2}$ within the parenthesis.

$$\therefore Ax^2 + Bx + C \equiv A \left[\left(x + \frac{B}{2A} \right)^2 + \frac{4AC - B^2}{4A^2} \right]. \quad \text{Q.E.D.}$$

4. Special quadratics. If one or both of the coefficients B and C in (1), p. 2, is zero, the quadratic is said to be **special**.

CASE I. $C = 0$.

Equation (1) now becomes, by factoring,

$$(1) \quad Ax^2 + Bx \equiv x(Ax + B) = 0.$$

Hence the roots are $x_1 = 0$, $x_2 = -\frac{B}{A}$. Therefore one root of a quadratic equation is zero if the constant term of that equation is zero. And *conversely*, if zero is a root of a quadratic, the constant term must disappear. For if $x = 0$ satisfies (1), p. 2, by substitution we have $C = 0$.

CASE II. $B = 0$.

Equation (1), p. 2, now becomes

$$(2) \quad Ax^2 + C = 0.$$

From Theorem I, p. 3, $x_1 + x_2 = 0$, that is,

$$(3) \quad x_1 = -x_2.$$

Therefore, if the coefficient of the first power of the unknown in a quadratic equation is zero, the roots are equal numerically but have opposite signs. Conversely, if the roots of a quadratic equation are numerically equal but opposite in sign, then the coefficient of the first power of the unknown must disappear. For, since the sum of the roots is zero, we must have, by Theorem I, $B = 0$.

CASE III. $B = C = 0$.

Equation (1), p. 2, now becomes

$$(4) \quad Ax^2 = 0.$$

Hence the roots are both equal to zero, since this equation requires that $x^2 = 0$, the coefficient A being, by hypothesis, always different from zero.

5. Cases when the roots of a quadratic are not independent.

If a relation exists between the roots x_1 and x_2 of the Typical Form

$$Ax^2 + Bx + C = 0,$$

then this relation imposes a *condition* upon the coefficients A , B , and C , which is expressed by an equation involving these constants.

For example, if the roots are equal, that is, if $x_1 = x_2$, then $B^2 - 4AC = 0$, by Theorem II, p. 3.

Again, if one root is zero, then $x_1x_2 = 0$; hence $C = 0$, by Theorem I, p. 3.

This correspondence may be stated in parallel columns thus:

Quadratic in Typical Form

<i>Relation between the roots</i>	<i>Equation of condition satisfied by the coefficients</i>
---------------------------------------	----------------------------------------------------------------

In many problems the coefficients involve one or more arbitrary constants, and it is often required to find the equation of condition satisfied by the latter when a given relation exists between the roots. Several examples of this kind will now be worked out.

Ex. 1. What must be the value of the parameter k if zero is a root of the equation

$$(1) \quad 2x^2 - 6x + k^2 - 3k - 4 = 0?$$

Solution. Here $A = 2$, $B = -6$, $C = k^2 - 3k - 4$. By Case I, p. 4, zero is a root when, and only when, $C = 0$.

$$\therefore k^2 - 3k - 4 = 0.$$

Solving, $k = 4$ or -1 . *Ans.*

Ex. 2. For what values of k are the roots of the equation

$$kx^2 + 2kx - 4x = 2 - 3k$$

real and equal?

Solution. Writing the equation in the Typical Form, we have

$$(2) \quad kx^2 + (2k - 4)x + (3k - 2) = 0.$$

Hence, in this case,

$$A = k, \quad B = 2k - 4, \quad C = 3k - 2.$$

Calculating the discriminant Δ , we get

$$\begin{aligned} \Delta &= (2k - 4)^2 - 4k(3k - 2) \\ &= -8k^2 - 8k + 16 = -8(k^2 + k - 2). \end{aligned}$$

By Theorem II, p. 3, the roots are real and equal when, and only when, $\Delta = 0$.

$$\therefore k^2 + k - 2 = 0.$$

Solving, $k = -2$ or 1 . *Ans.*

Verifying by substituting these answers in the given equation (2):

when $k = -2$, the equation (2) becomes $-2x^2 - 8x - 8 = 0$, or $-2(x+2)^2 = 0$;

when $k = 1$, the equation (2) becomes $x^2 - 2x + 1 = 0$, or $(x-1)^2 = 0$.

Hence, for these values of k , the left-hand member of (2) may be transformed as in (7), p. 4.

Ex. 3. What equation of condition must be satisfied by the constants a , b , k , and m if the roots of the equation

$$(3) \quad (b^2 + a^2m^2)y^2 + 2a^2kmy + a^2k^2 - a^2b^2 = 0$$

are equal?

Solution. The equation (3) is already in the Typical Form; hence

$$A = b^2 + a^2m^2, \quad B = 2a^2km, \quad C = a^2k^2 - a^2b^2.$$

By Theorem II, p. 3, the discriminant Δ must vanish; hence

$$\Delta = 4a^4k^2m^2 - 4(b^2 + a^2m^2)(a^2k^2 - a^2b^2) = 0.$$

Multiplying out and reducing,

$$a^2b^2(k^2 - a^2m^2 - b^2) = 0. \quad \text{Ans.}$$

Ex. 4. For what values of k do the common solutions of the simultaneous equations

$$(4) \quad 3x + 4y = k,$$

$$(5) \quad x^2 + y^2 = 25$$

become identical?

Solution. Solving (4) for y , we have

$$(6) \quad y = \frac{1}{4}(k - 3x).$$

Substituting in (5) and arranging in the Typical Form gives

$$(7) \quad 25x^2 - 6kx + k^2 - 400 = 0.$$

Let the roots of (7) be x_1 and x_2 . Then substituting in (6) will give the corresponding values y_1 and y_2 of y , namely,

$$(8) \quad y_1 = \frac{1}{4}(k - 3x_1), \quad y_2 = \frac{1}{4}(k - 3x_2),$$

and we shall have two common solutions (x_1, y_1) and (x_2, y_2) of (4) and (5). But, by the condition of the problem, *these solutions must be identical*. Hence we must have

$$(9) \quad x_1 = x_2 \text{ and } y_1 = y_2.$$

If, however, the first of these is true ($x_1 = x_2$), then from (8) y_1 and y_2 will also be equal.

Therefore the two common solutions of (4) and (5) become identical when, and only when, the roots of the equation (7) are equal; that is, when the discriminant Δ of (7) vanishes (Theorem II, p. 3).

$$\therefore \Delta = 36k^2 - 100(k^2 - 400) = 0.$$

Solving,

$$k^2 = 625,$$

$$k = 25 \text{ or } -25. \quad \text{Ans.}$$

Verification. Substituting each value of k in (7),

when $k = 25$, the equation (7) becomes $x^2 - 6x + 9 = 0$, or $(x - 3)^2 = 0$; $\therefore x = 3$;

when $k = -25$, the equation (7) becomes $x^2 + 6x + 9 = 0$, or $(x + 3)^2 = 0$; $\therefore x = -3$.

Then from (6), substituting corresponding values of k and x ,

$$\text{when } k = 25 \text{ and } x = 3, \text{ we have } y = \frac{1}{4}(25 - 9) = 4;$$

$$\text{when } k = -25 \text{ and } x = -3, \text{ we have } y = \frac{1}{4}(-25 + 9) = -4.$$

Therefore the two common solutions of (4) and (5) are identical for each of these values of k , namely,

$$\text{if } k = 25, \text{ the common solutions reduce to } x = 3, y = 4;$$

$$\text{if } k = -25, \text{ the common solutions reduce to } x = -3, y = -4.$$

PROBLEMS

1. Calculate the discriminant of each of the following quadratics, determine the sum, the product, and the character of the roots, and write each quadratic in one of the forms (7), p. 4.

- | | |
|------------------------|---------------------------------|
| (a) $2x^2 - 6x + 4$. | (i) $5x^2 - x - 1$. |
| (b) $x^2 - 9x - 10$. | (j) $7x^2 - 6x - 1$. |
| (c) $1 - x - x^2$. | (k) $3x^2 - 5$. |
| (d) $4x^2 - 4x + 1$. | (l) $2x^2 + x - 8$. |
| (e) $5x^2 + 10x + 5$. | (m) $2x^2 + x + 8$. |
| (f) $3x^2 - 5x - 22$. | (n) $6x^2 - x - 5$. |
| (g) $2x^2 + 13$. | (o) $10x^2 + 60x + 90$. |
| (h) $9x^2 - 6x + 1$. | (p) $7x^2 + 7x + \frac{7}{4}$. |

2. For what real values of the parameter k will one root of each of the following equations have the value assigned?

One root to be zero:

- | | |
|----------------------------------------|-----------------------------------------------------------|
| (a) $6x^2 + 5kx - 3k^2 + 3 = 0$. | <i>Ans.</i> $k = \pm 1$. |
| (b) $2k - 3x^2 + 6x - k^2 + 3 = 0$. | <i>Ans.</i> $k = -1$ or 3 . |
| (c) $x^2 + 10x + k^2 + 3 = 0$. | <i>Ans.</i> None. |
| (d) $10x^2 - mx + 3k^2 - 8k + 2 = 0$. | <i>Ans.</i> $k = \frac{4}{3} \pm \frac{1}{3} \sqrt{10}$. |

One root to be -2 :

- | | |
|-----------------------------------|------------------------------------------|
| (e) $x^2 - 2kx + 3 = 0$. | <i>Ans.</i> $k = -\frac{7}{4}$. |
| (f) $kx^2 - x + 3k^2 - 1 = 0$. | <i>Ans.</i> $k = -\frac{1}{3}$ or -1 . |
| (g) $k^2x^2 + 6x = k^2 - 16$. | <i>Ans.</i> None. |
| (h) $kx^2 + 2kx = -3$. | <i>Ans.</i> None. |
| (i) $10x^2 - 7kx + k^2 + 9 = 0$. | <i>Ans.</i> $k = -7$. |

3. For what real values of k and m will both roots of each of the following quadratic equations be zero?

- | | |
|------------------------------------------------|--------------------------------------------------|
| (a) $5x^2 + mx + k - 5 = x$. | <i>Ans.</i> $k = 5, m = 1$. |
| (b) $x^2 + (3k - m)x + k^2 - 4 = 0$. | <i>Ans.</i> $k = \pm 2, m = \pm 6$. |
| (c) $2x^2 + (m^2 + 1)x + k^2 = 0$. | <i>Ans.</i> None. |
| (d) $x^2 + (m^2 + 2k - 3m)x + 4k - 6m = 0$. | <i>Ans.</i> $k = 0, m = 0$. |
| (e) $t^2 + (m^2 + k^2 - 5)t + k + m + 1 = 0$. | <i>Ans.</i> $k = 1, m = -2$
$k = -2, m = 1$. |

4. For what real values of the parameter are the roots of the following equations equal? Verify your answers.

- | | |
|------------------------------|--------------------------------------|
| (a) $kx^2 - 3x - 1 = 0$. | <i>Ans.</i> $k = -\frac{9}{4}$. |
| (b) $x^2 - kx + 9 = 0$. | <i>Ans.</i> $k = \pm 6$. |
| (c) $2kx^2 + 3kx + 12 = 0$. | <i>Ans.</i> $k = \frac{3}{2}$. |
| (d) $2x^2 + kx - 1 = 0$. | <i>Ans.</i> None. |
| (e) $5x^2 - 3x + 5k^2 = 0$. | <i>Ans.</i> $k = \pm \frac{3}{10}$. |

- (f) $x^2 + kx + k^2 + 2 = 0$. *Ans.* None.
 (g) $x^2 + 2kx - k - \frac{1}{4} = 0$. *Ans.* $k = -\frac{1}{2}$.
 (h) $x^2 + 2bx + 2b^2 + 3b - 4 = 0$. *Ans.* $b = -4$ or 1 .
 (i) $(m + 2)x^2 - 2mx + 1 = 0$. *Ans.* $m = -1$ or 2 .
 (j) $(m^2 + 4)x^2 + 3x + 2 = 0$. *Ans.* None.
 (k) $x^2 + (l - 3)x - 1 = 0$. *Ans.* None.
 (l) $(c^2 - 8)y^2 - (2c - 1)y + \frac{1}{2} = 0$. *Ans.* None.
 (m) $ax^2 + 2(a + 3)z + 16 = 0$. *Ans.* $a = 1$ or 9 .

5. Derive the equation of condition in order that the roots of the following equations may be equal.

- (a) $m^2x^2 + 2kmx - 2px = -k^2$. *Ans.* $p(p - 2km) = 0$.
 (b) $x^2 + 2mpx + 2bp = 0$. *Ans.* $p(m^2p - 2b) = 0$.
 (c) $2mx^2 + 2bx + a^2 = 0$. *Ans.* $b^2 = 2a^2m$.
 (d) $(1 + m^2)x^2 + 2bmx + (b^2 - r^2) = 0$. *Ans.* $b^2 = r^2(1 + m^2)$.
 (e) $(b^2 - a^2m^2)y^2 - 2b^2ky = a^2b^2m^2 - b^2k^2$. *Ans.* $a^2b^2m^2(k^2 - a^2m^2 + b^2) = 0$.
 (f) $(A + m^2B)x^2 + 2bmBx + b^2B + C = 0$. *Ans.* $b^2AB + m^2BC + AC = 0$.

6. For what real values of the parameter do the common solutions of the following pairs of simultaneous equations become identical?

- (a) $x + 2y = k$, $x^2 + y^2 = 5$. *Ans.* $k = \pm 5$.
 (b) $y = mx - 1$, $x^2 = 4y$. *Ans.* $m = \pm 1$.
 (c) $2x - 3y = b$, $x^2 + 2x = 3y$. *Ans.* $b = 0$.
 (d) $y = mx + 10$, $x^2 + y^2 = 10$. *Ans.* $m = \pm 3$.
 (e) $lx + y - 2 = 0$, $x^2 - 8y = 0$. *Ans.* None.
 (f) $x + 4y = c$, $x^2 + 2y^2 = 9$. *Ans.* $c = \pm 9$.
 (g) $x^2 + y^2 - x - 2y = 0$, $x + 2y = c$. *Ans.* $c = 0$ or 5 .
 (h) $x^2 + 4y^2 - 8x = 0$, $mx - y - 2m = 0$. *Ans.* None.
 (i) $x^2 + y^2 - k = 0$, $3x - 4y = 25$. *Ans.* $k = 25$.
 (j) $x^2 - y^2 + 2x - y = 3$, $4x + y = c$. *Ans.* $c = -12$ or 3 .
 (k) $2xy - 3x - y = 0$, $y + 3x + k = 0$. *Ans.* $k = -6$ or 0 .
 (l) $x^2 + 4y^2 - 8y = 0$, $x = c$. *Ans.* $c = \pm 2$.
 (m) $x^2 + 4y^2 - 8y = 0$, $y = b$. *Ans.* $b = 0, 2$.
 (n) $2x^2 + 3y^2 = 35$, $4x + 9y = k$. *Ans.* $k = \pm 35$.
 (o) $x^2 + xy + 2x + y = 0$, $y = -2x + b$. *Ans.* $b = -4$ or 0 .

7. If the common solutions of the following pairs of simultaneous equations are to become identical, what is the corresponding equation of condition?

- (a) $bx + ay = ab$, $y^2 = 2px$. *Ans.* $ap(2b^2 + ap) = 0$.
 (b) $y = mx + b$, $Ax^2 + By = 0$. *Ans.* $B(m^2B - 4bA) = 0$.
 (c) $y = m(x - a)$, $By^2 + Dx = 0$. *Ans.* $D(4am^2B - D) = 0$.
 (d) $bx + ay = ab$, $2xy + c^2 = 0$. *Ans.* $ab(ab + 2c^2) = 0$.
 (e) $kx - y = c$, $Ax^2 + By^2 = C$. *Ans.* $c^2AB - k^2BC - AC = 0$.
 (f) $x \cos \alpha + y \sin \alpha = p$, $x^2 + y^2 = r^2$. *Ans.* $p^2 = r^2$.

6. Variables. A *variable* is a quantity to which, in the same investigation, an unlimited number of values can be assigned. In a particular problem the variable may, in general, assume any value within certain limits imposed by the nature of the problem. It is convenient to indicate these limits by *inequalities*.

For example, if the variable x can assume any value between -2 and 5 , that is, if x must be greater* than -2 and less than 5 , the simultaneous inequalities

$$x > -2, x < 5,$$

are written in the more compact form

$$-2 < x < 5.$$

Similarly, if the conditions of the problem limit the values of the variable x to any negative number less than or equal to -2 , and to any positive number greater than or equal to 5 , the conditions

$$x < -2 \text{ or } x = -2, \text{ and } x > 5 \text{ or } x = 5$$

are abbreviated to

$$x \leq -2 \text{ and } x \geq 5.$$

7. Variation in sign of a quadratic. In many problems it is important to determine the algebraic signs of the results obtained by substituting in a quadratic different values for the variable unknown, that is, to determine the algebraic signs of the values of a quadratic for given values of the variable. The discussion of this question depends upon the definitions of greater and less already given, the precise point necessary being the statement:

If a is a given real constant and x a real variable, then

$$(1) \quad \begin{cases} \text{when } x < a, x - a \text{ is a negative number;} \\ \text{when } x > a, x - a \text{ is a positive number.} \end{cases}$$

By the aid of this statement and the identities (7), p. 4, we easily prove

*The meaning of *greater* and *less* for *real* numbers (§ 1) is defined as follows: a is greater than b when $a - b$ is a positive number, and a is less than b when $a - b$ is negative. Hence any negative number is less than any positive number; and if a and b are both negative, then a is *greater* than b when the *numerical* value of a is *less* than the numerical value of b .

Thus $3 < 5$, but $-3 > -5$. Therefore changing signs throughout an inequality reverses the inequality sign.

Theorem III. *If the discriminant of a quadratic is positive, the value of the quadratic* and the coefficient of the second power differ in sign for all values of the variable lying between the roots, and agree in sign for all other values.*

If the discriminant is zero or negative, the value of the quadratic and the coefficient of the second power always agree in sign.

Proof. Denoting the variable by x , and writing the quadratic in the Typical Form, (1), p. 2, we have, by (7), p. 4,

CASE I. $Ax^2 + Bx + C \equiv A(x - x_1)(x - x_2)$ if Δ is positive.

CASE II. $Ax^2 + Bx + C \equiv A(x - x_1)^2$ if Δ is zero.

CASE III. $Ax^2 + Bx + C \equiv A \left[\left(x + \frac{B}{2A} \right)^2 + \frac{4AC - B^2}{4A^2} \right]$ if Δ is negative.

Consider these cases in turn.

CASE I. Since the roots are unequal, let $x_1 < x_2$. Then, by (1), we have at once

$$(x - x_1)(x - x_2) \text{ is negative when } x_1 < x < x_2,$$

since $x - x_1$ is positive, and $x - x_2$ is negative;

$$(x - x_1)(x - x_2) \text{ is positive when } x < x_1 \text{ or } x > x_2,$$

since $x - x_1$ and $x - x_2$ are both negative or both positive.

Therefore the quadratic has the sign of $-A$ in one case, and of A in the other.

CASE II. Since $(x - x_1)^2$ is positive (p. 1), the sign of the quadratic agrees with that of A .

CASE III. Since Δ is negative, $4AC - B^2 \equiv -\Delta$ is positive; hence the expression within the brackets is always positive, and the sign is the same as that of A . Q.E.D.

For example, consider the quadratic

$$2t^2 - 3t + 1.$$

Here $\Delta = 9 - 8 = +1$, $A = 2$, and the roots are $\frac{1}{2}$ and 1.

$$\therefore 2t^2 - 3t + 1 \equiv 2(t - \frac{1}{2})(t - 1).$$

*It is assumed that all the numbers involved are *real*. Also, since the value of the quadratic is zero for a value of the variable equal to a root, any such value of the variable is excluded.

If now any real number be substituted for t in the quadratic, it will be found that

when $\frac{1}{2} < t < 1$, the quadratic $2t^2 - 3t + 1 < 0$;

when $t < \frac{1}{2}$ or $t > 1$, the quadratic $2t^2 - 3t + 1 > 0$.

Again, consider the quadratic in r ,

$$3r^2 + 4r + 9.$$

Here $\Delta = 16 - 108 = -92$, and $A = 3$. Hence, by Theorem III, if any real number whatever be substituted for r , the result will always be a positive number.

Applications of Theorem III. The following examples illustrate applications of Theorem III.

Ex. 1. Determine all real values of the variable for which the following radicals are real.

$$(a) \sqrt{3 - 2x - x^2}; \quad (b) \sqrt{2y^2 + 3y + 9}.$$

Solution. Consider the quadratic under the radical.

In (a), $\Delta = 4 + 12 = 16$, $A = -1$, and the roots are 1 and -3 .

Applying Theorem III,

when $-3 < x < 1$, the quadratic $3 - 2x - x^2 > 0$;

when $x < -3$ or $x > 1$, the quadratic $3 - 2x - x^2 < 0$.

Since under the condition of the problem the given quadratic must be either positive or zero, we have $-3 \leq x \leq 1$. *Ans.*

In (b), $\Delta = 9 - 72 = -63$, and $A = 2$. Hence, by Theorem III, the quadratic is positive, and therefore the square root is real for every real value of y . *Ans.*

Ex. 2. For what values of the parameter k are the roots of the equation

$$(2) \quad kx^2 + 2kx - 4x = 2 - 3k$$

(a) real and unequal? (b) imaginary?

Solution. Writing the equation in the Typical Form,

$$kx^2 + (2k - 4)x + 3k - 2 = 0,$$

we find

$$(3) \quad \Delta \equiv B^2 - 4AC = -8(k^2 + k - 2).$$

(See Ex. 2, p. 6.)

By Theorem II, p. 3,

(a) the roots are real and unequal if $-8(k^2 + k - 2) > 0$;

(b) the roots are imaginary if $-8(k^2 + k - 2) < 0$.

Applying Theorem III to the quadratic

$$-8(k^2 + k - 2),$$

we have, since $\Delta = 64 + 512 = 576$, $A = -8$, and the roots are -2 and 1 ,
 when $-2 < k < 1$, the quadratic $-8(k^2 + k - 2) > 0$;
 when $k < -2$ or $k > 1$, the quadratic $-8(k^2 + k - 2) < 0$.

Hence

(a) the roots of (2) are real and unequal if $-2 < k < 1$;

(b) the roots of (2) are imaginary if $k < -2$ or $k > 1$. *Ans.*

Ex. 3. Show that the simultaneous equations

$$(4) \quad y = mx + 3$$

$$(5) \quad 4x^2 + y^2 + 6x - 16 = 0$$

have two real and distinct common solutions for every real value of m .

Solution. Substituting the value of y from (4) in (5), and arranging the result in the Typical Form, we get

$$(6) \quad (4 + m^2)x^2 + (6m + 6)x - 7 = 0.$$

Calculating the discriminant of (6), we find, neglecting the positive factor 4,

$$(7) \quad 16m^2 + 18m + 37.$$

Applying Theorem III, p. 11, to the quadratic (7),

$$\Delta = 324 - 64 \cdot 37 \text{ is negative, } A = 16.$$

Therefore the quadratic (7) has a positive value for every real value of m , and hence the roots of (6) are, by Theorem II, p. 3, always real and unequal. That is, (6) always has two real roots, x_1 and x_2 , and from (4) we find the corresponding real values of y , namely, y_1 and y_2 , so that the equations (4) and (5) have two real and distinct common solutions, (x_1, y_1) , (x_2, y_2) , for every value of m . Q. E. D.

PROBLEMS

1. Write inequalities to express that the values of the variable named are limited as stated.

(a) x has any value from 0 to 5 inclusive.

(b) y has any positive value.

(c) t has any negative value.

(d) x has any value less than -2 or greater than -1 .

(e) r has any value from -3 to 8 inclusive.

(f) z has any negative value, or any positive value not less than 3.

(g) x has any value not less than -8 nor greater than 2.

2. Determine the sign of each of the quadratics of the first problem on p. 8 for all values of the variable.

3. Determine all real values of the variable for which the square root of the quadratics of problem 1, p. 8, are real.

4. Determine all real values of the parameter for which the roots of each equation of problem 4, p. 8, are (a) real and unequal; (b) imaginary.

5. In problem 6, p. 9, find all real values of the parameter in each case such that the two common solutions are (a) real and unequal; (b) imaginary.

6. Determine the algebraic sign of the value of the cubic

$$2(x+1)(x-2)(x-4)$$

for any value of the variable.

Hint. In this case the roots are $-1, 2, 4$ in the order of magnitude. Hence, when $x < -1$, each factor is negative [(1), p. 10] and the cubic is negative, etc.

Ans. For $x < -1$, cubic < 0 ; $-1 < x < 2$, cubic > 0 ; $2 < x < 4$, cubic < 0 ; $4 < x$, cubic > 0 .

7. Determine the sign of the value of each of the following quantics for any value of the variable.

Hint. From Algebra we know that any quantic with real coefficients may be resolved into real factors of the first and second degrees. The sign of each factor for any value of the variable may then be determined by (1), p. 10, and Theorem III, p. 11. It is well first to arrange the real roots of the quantic in the order of magnitude, and then it is necessary to consider only values of the variable less than any root, lying between each successive pair, and greater than any root, as in problem 6.

- | | |
|---------------------------------|--------------------------------------|
| (a) $(x+1)(2x^2-4x+7)$. | (f) $(x^2-9)(x^2-16)(x^2-25)$. |
| (b) $(x^2-2x-3)(x^3-4x^2)$. | (g) $(3x^2-12)(2-x)(3-2x)(5x+4)$. |
| (c) $(3x+8)(x^2-4x+4)(x^3-1)$. | (h) $(x-1)^2(3+2x)(4-5x)(6-x)^3$. |
| (d) $(2x^2+3)(x^2-4)(x^4-1)$. | (i) $7(x^2-4)(9-x^2)(16-x^2)$. |
| (e) $(2x+3)(x-1)(x+2)(x-3)$. | (j) $(x^2-8)(2x^2-8)(3x^2-27)$. |
| | (k) $(2x+8)^2(9-3x)(7-6x)(12-11x)$. |

8. Infinite roots. Consider the quadratic equation

$$(1) \quad Ax^2 + Bx + C = 0,$$

whose roots are x_1 and x_2 [(3), p. 3].

Then the equation

$$(2) \quad Cx^2 + Bx + A = 0,$$

obtained from (1) by reversing the order of the coefficients, has the roots* $\frac{1}{x_1}$ and $\frac{1}{x_2}$, that is, the *reciprocals* of the roots of (1).

Let us now fix the values † of B and C , but allow A to diminish indefinitely in numerical value, that is, allow A to approach zero. Then, in (2), since $\frac{A}{C}$ (Theorem I, p. 3) is the product of the roots, this product must also approach zero. Therefore one root of (2) must approach zero; and hence its reciprocal, that is, one root of (1), must *increase* indefinitely.

Again, let us in (1) and (2) fix the value † of C only, and assume that both B and A approach zero. Then, in (2), both the sum, $-\frac{B}{C}$, and the product, $\frac{A}{C}$, of the roots approach zero, and hence both roots also approach zero. Hence their reciprocals, the roots of (1), must increase indefinitely.

This reasoning establishes

Theorem IV. *If the coefficient of the second power in a quadratic equation is variable and approaches zero as a limit, then one root of the equation becomes infinite. ‡ If the coefficient of the first power is also variable and approaches zero as a limit, then both roots become infinite.*

Ex. 1. What value must the variable k approach as a limit in order that a root of the equation

$$3x^2 + 2kx - k^2x^2 - 3 - 2kx^2 = 0$$

may become infinite?

Solution. Arranging the equation in the Typical Form, we have

$$(k^2 + 2k - 3)x^2 - 2kx + 3 = 0.$$

If $k^2 + 2k - 3 = 0$, then one root must become infinite. Hence k must approach 1 or -3 . *Ans.*

* This theorem is demonstrated in Algebra and may be easily verified thus:

The equation whose roots are $\frac{1}{x_1}$ and $\frac{1}{x_2}$ is $(x - \frac{1}{x_1})(x - \frac{1}{x_2}) = 0$.

Multiplying out and reducing, this becomes $x_1x_2 \cdot x^2 - (x_1 + x_2) \cdot x + 1 = 0$.

By Theorem I, p. 3, $x_1x_2 = \frac{C}{A}$, $x_1 + x_2 = -\frac{B}{A}$, and substitution of these values and multiplication by A gives (2).

† We give C a value different from zero.

‡ A variable whose numerical value becomes greater than any assigned number is said to "become infinite."

Ex. 2. What values must k and m approach in order to make both roots of the equation

$$(b^2 - a^2m^2)x^2 - 2a^2kmx - a^2k^2 - a^2b^2 = 0$$

become infinite?

Solution. By Theorem IV we must have

$$b^2 - a^2m^2 = 0, \text{ or } m = \pm \frac{b}{a},$$

and

$$2a^2km = 0, \text{ or } k = 0.$$

Hence m must approach $+\frac{b}{a}$ or $-\frac{b}{a}$, and k must approach zero. *Ans.*

PROBLEMS

1. What real value must the parameter approach as a limit in each of the following equations in order to make a root become infinite?

(a) $kx^2 - 3x + 5 = 0.$

(d) $(m^2 - 4)x^2 - 3x + 8 = 0.$

(b) $(k^2 - 1)x^2 + 6x - 5 = 0.$

(e) $(c^2 - 3)y^2 + 2cy - 6 = 0.$

(c) $2x^2 - 3x + k^2x^2 + 5 = kx^2.$

(f) $2b^2y^2 - 3y - 3by^2 + 2 = -2y^2.$

2. What real values must the parameters k and m approach in order that both roots of each of the following equations may become infinite?

(a) $m^2x^2 + (2k - m + 1)x + 6 = 0.$

(b) $(m^2 - 3m + 2)y^2 + (3k - 2m)y + 2 = 0.$

(c) $(m^2 + k^2 - 25)t^2 + (m - 7k + 25)t + 8 = 0.$

(d) $m^2x^2 + 3kx + k^2x^2 - 4mx + 25x - 25x^2 = 2.$

(e) $(m^2 + 3)x^2 + (2k - 5)x + 8 = 0.$

9. Equations in several variables. In Analytic Geometry we are concerned chiefly with equations in two or more variables.

An equation is *said to be satisfied* by any given set of values of the variables if the equation reduces to a numerical equality when these values are substituted for the variables.

For example, $x = 2, y = -3$ satisfy the equation

$$2x^2 + 3y^2 = 35,$$

since

$$2(2)^2 + 3(-3)^2 = 35.$$

Similarly, $x = -1, y = 0, z = -4$ satisfy the equation

$$2x^2 - 3y^2 + z^2 - 18 = 0,$$

since

$$2(-1)^2 - 3.0 + (-4)^2 - 18 = 0.$$

An equation is said to be **algebraic** in any number of variables, for example x, y, z , if it can be transformed into an equation each of whose members is a sum of terms of the form $ax^m y^n z^p$, where a is a constant and m, n, p are positive integers or zero.

Thus the equations
$$x^4 + x^2 y^2 - z^3 + 2x - 5 = 0,$$

$$x^5 y + 2x^2 y^2 = -y^3 + 5x^2 + 2 - x$$
 are algebraic.

The equation
$$x^{\frac{1}{2}} + y^{\frac{1}{2}} = a^{\frac{1}{2}}$$
 is algebraic.

For, squaring, we get $x + 2x^{\frac{1}{2}}y^{\frac{1}{2}} + y = a$.

Transposing,
$$2x^{\frac{1}{2}}y^{\frac{1}{2}} = a - x - y.$$

Squaring,
$$4xy = a^2 + x^2 + y^2 - 2ax - 2ay + 2xy.$$

Transposing,
$$x^2 + y^2 - 2xy - 2ax - 2ay + a^2 = 0.$$
 Q.E.D.

The **degree** of an algebraic equation is equal to the highest degree of any of its terms.* An algebraic equation is said to be **arranged with respect to the variables** when all its terms are transposed to the left-hand side and written in the order of descending degrees.

For example, to *arrange* the equation

$$2x'^2 + 3y' + 6x' - 2x'y' - 2 + x'^3 = x'^2 y' - y'^2$$

with respect to the variables x', y' , we transpose and rewrite the terms in the order

$$x'^3 - x'^2 y' + 2x'^2 - 2x'y' + y'^2 + 6x' + 3y' - 2 = 0.$$

This equation is of the third degree.

An equation which is not algebraic is said to be **transcendental**.

Examples of transcendental equations are

$$y = \sin x, \quad y = 2^x, \quad \log y = 3x.$$

PROBLEMS

1. Show that each of the following equations is algebraic; arrange the terms according to the variables x, y , or x, y, z , and determine the degree.

(a) $x^2 + \sqrt{y-5} + 2x = 0.$

(b) $x^3 + y + 3x = 0.$

(c) $xy + 3x^4 + 6x^2y - 7xy^3 + 5x - 6 + 8y = 2xy^2.$

(d) $x + y + z + x^2z - 3xy - 2z^2 = 5.$

(e) $y = 2 + \sqrt{x^2 - 2x - 5}.$

* The degree of any term is the sum of the exponents of the variables in that term.

$$(f) y = x + 5 + \sqrt{2x^2 - 6x + 3}.$$

$$(g) x = -\frac{1}{2}D + \sqrt{\frac{D^2}{4} - F - Ey - y^2}.$$

$$(h) y = Ax + B + \sqrt{Lx^2 + Mx + N}.$$

2. Show that the homogeneous quadratic *

$$Ax^2 + Bxy + Cy^2$$

may be written in one of the three forms below analogous to (7), p. 4, if the discriminant $\Delta \equiv B^2 - 4AC$ satisfies the condition given :

CASE I. $Ax^2 + Bxy + Cy^2 \equiv A(x - l_1y)(x - l_2y)$, if $\Delta > 0$;

CASE II. $Ax^2 + Bxy + Cy^2 \equiv A(x - l_1y)^2$, if $\Delta = 0$;

CASE III. $Ax^2 + Bxy + Cy^2 \equiv A \left[\left(x + \frac{B}{2A}y \right)^2 + \frac{4AC - B^2}{4A^2}y^2 \right]$, if $\Delta < 0$.

10. **Functions of an angle in a right triangle.** In any right triangle one of whose acute angles is A , the functions of A are defined as follows :

$$\begin{aligned} \sin A &= \frac{\text{opposite side}}{\text{hypotenuse}}, & \csc A &= \frac{\text{hypotenuse}}{\text{opposite side}}, \\ \cos A &= \frac{\text{adjacent side}}{\text{hypotenuse}}, & \sec A &= \frac{\text{hypotenuse}}{\text{adjacent side}}, \\ \tan A &= \frac{\text{opposite side}}{\text{adjacent side}}, & \cot A &= \frac{\text{adjacent side}}{\text{opposite side}}. \end{aligned}$$

From the above the theorem is easily derived :

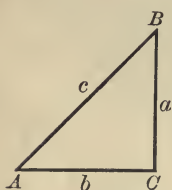

In a right triangle a side is equal to the product of the hypotenuse and the sine of the angle opposite to that side, or of the hypotenuse and the cosine of the angle adjacent to that side.

11. **Angles in general.** In Trigonometry an angle XOA is considered as generated by the line OA rotating from an initial position OX . The angle is positive when OA rotates from OX counter-clockwise, and negative when the direction of rotation of OA is clockwise.

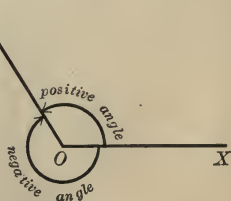

* The coefficients A, B, C and the numbers l_1, l_2 are supposed real.

The fixed line OX is called the *initial line*, the line OA the *terminal line*.

Measurement of angles. There are two important methods of measuring angular magnitude, that is, there are two unit angles.

Degree measure. The unit angle is $\frac{1}{360}$ of a complete revolution, and is called a *degree*.

Circular measure. The unit angle is an angle whose subtending arc is equal to the radius of that arc, and is called a *radian*.

The fundamental relation between the unit angles is given by the equation

$$180 \text{ degrees} = \pi \text{ radians } (\pi = 3.14159 \dots).$$

Or also, by solving this,

$$1 \text{ degree} = \frac{\pi}{180} = .0174 \dots \text{ radians,}$$

$$1 \text{ radian} = \frac{180}{\pi} = 57.29 \dots \text{ degrees.}$$

These equations enable us to change from one measurement to another. In the higher mathematics circular measure is always used, and will be adopted in this book.

The generating line is conceived of as rotating around O through as many revolutions as we choose. Hence the important result:

Any real number is the circular measure of some angle, and conversely, any angle is measured by a real number.

12. Formulas and theorems from Trigonometry.

$$1. \cot x = \frac{1}{\tan x}; \sec x = \frac{1}{\cos x}; \csc x = \frac{1}{\sin x}.$$

$$2. \tan x = \frac{\sin x}{\cos x}; \cot x = \frac{\cos x}{\sin x}$$

$$3. \sin^2 x + \cos^2 x = 1; 1 + \tan^2 x = \sec^2 x; 1 + \cot^2 x = \csc^2 x.$$

$$4. \sin(-x) = -\sin x; \csc(-x) = -\csc x;$$

$$\cos(-x) = \cos x; \sec(-x) = \sec x;$$

$$\tan(-x) = -\tan x; \cot(-x) = -\cot x.$$

$$\begin{aligned} 5. \quad \sin(\pi - x) &= \sin x; \quad \sin(\pi + x) = -\sin x; \\ \cos(\pi - x) &= -\cos x; \quad \cos(\pi + x) = -\cos x; \\ \tan(\pi - x) &= -\tan x; \quad \tan(\pi + x) = \tan x; \end{aligned}$$

$$\begin{aligned} 6. \quad \sin\left(\frac{\pi}{2} - x\right) &= \cos x; \quad \sin\left(\frac{\pi}{2} + x\right) = \cos x; \\ \cos\left(\frac{\pi}{2} - x\right) &= \sin x; \quad \cos\left(\frac{\pi}{2} + x\right) = -\sin x; \\ \tan\left(\frac{\pi}{2} - x\right) &= \cot x; \quad \tan\left(\frac{\pi}{2} + x\right) = -\cot x. \end{aligned}$$

$$7. \quad \sin(2\pi - x) = \sin(-x) = -\sin x, \text{ etc.}$$

$$8. \quad \sin(x + y) = \sin x \cos y + \cos x \sin y.$$

$$9. \quad \sin(x - y) = \sin x \cos y - \cos x \sin y.$$

$$10. \quad \cos(x + y) = \cos x \cos y - \sin x \sin y.$$

$$11. \quad \cos(x - y) = \cos x \cos y + \sin x \sin y.$$

$$12. \quad \tan(x + y) = \frac{\tan x + \tan y}{1 - \tan x \tan y}. \quad 13. \quad \tan(x - y) = \frac{\tan x - \tan y}{1 + \tan x \tan y}.$$

$$14. \quad \sin 2x = 2 \sin x \cos x; \quad \cos 2x = \cos^2 x - \sin^2 x; \quad \tan 2x = \frac{2 \tan x}{1 - \tan^2 x}.$$

$$15. \quad \sin \frac{x}{2} = \pm \sqrt{\frac{1 - \cos x}{2}}; \quad \cos \frac{x}{2} = \pm \sqrt{\frac{1 + \cos x}{2}}; \quad \tan \frac{x}{2} = \pm \sqrt{\frac{1 - \cos x}{1 + \cos x}}.$$

16. *Theorem. Law of sines.* In any triangle the sides are proportional to the sines of the opposite angles;

that is,
$$\frac{a}{\sin A} = \frac{b}{\sin B} = \frac{c}{\sin C}.$$

17. *Theorem. Law of cosines.* In any triangle the square of a side equals the sum of the squares of the two other sides diminished by twice the product of those sides by the cosine of their included angle;

that is,
$$a^2 = b^2 + c^2 - 2bc \cos A.$$

18. *Theorem. Area of a triangle.* The area of any triangle equals one half the product of two sides by the sine of their included angle;

that is,
$$\text{area} = \frac{1}{2} ab \sin C = \frac{1}{2} bc \sin A = \frac{1}{2} ca \sin B.$$

13. Natural values of trigonometric functions.

Angle in Radians	Angle in Degrees	Sin	Cos	Tan	Cot		
.0000	0°	.0000	1.0000	.0000	∞	90°	1.5708
.0873	5°	.0872	.9962	.0875	11.430	85°	1.4835
.1745	10°	.1736	.9848	.1763	5.671	80°	1.3963
.2618	15°	.2588	.9659	.2679	3.732	75°	1.3090
.3491	20°	.3420	.9397	.3640	2.747	70°	1.2217
.4363	25°	.4226	.9063	.4663	2.145	65°	1.1345
.5236	30°	.5000	.8660	.5774	1.732	60°	1.0472
.6109	35°	.5736	.8192	.7002	1.428	55°	.9599
.6981	40°	.6428	.7660	.8391	1.192	50°	.8727
.7854	45°	.7071	.7071	1.0000	1.000	45°	.7854
		Cos	Sin	Cot	Tan	Angle in Degrees	Angle in Radians

Angle in Radians	Angle in Degrees	Sin	Cos	Tan	Cot	Sec	Csc
0	0°	0	1	0	∞	1	∞
$\frac{\pi}{2}$	90°	1	0	∞	0	∞	1
π	180°	0	-1	0	∞	-1	∞
$\frac{3\pi}{2}$	270°	-1	0	∞	0	∞	-1
2π	360°	0	1	0	∞	1	∞

Angle in Radians	Angle in Degrees	Sin	Cos	Tan	Cot	Sec	Csc
0	0°	0	1	0	∞	1	∞
$\frac{\pi}{6}$	30°	$\frac{1}{2}$	$\frac{\sqrt{3}}{2}$	$\frac{\sqrt{3}}{3}$	$\sqrt{3}$	$\frac{2\sqrt{3}}{3}$	2
$\frac{\pi}{4}$	45°	$\frac{\sqrt{2}}{2}$	$\frac{\sqrt{2}}{2}$	1	1	$\sqrt{2}$	$\sqrt{2}$
$\frac{\pi}{3}$	60°	$\frac{\sqrt{3}}{2}$	$\frac{1}{2}$	$\sqrt{3}$	$\frac{\sqrt{3}}{3}$	2	$\frac{2\sqrt{3}}{3}$
$\frac{\pi}{2}$	90°	1	0	∞	0	∞	1

14. Rules for signs.

Quadrant	Sin	Cos	Tan	Cot	Sec	Csc
First	+	+	+	+	+	+
Second	+	-	-	-	-	+
Third	-	-	+	+	-	-
Fourth	-	+	-	-	+	-

15. Greek alphabet.

Letters	Names	Letters	Names	Letters	Names
A α	Alpha	I ι	Iota	P ρ	Rho
B β	Beta	K κ	Kappa	Σ σ ς	Sigma
Γ γ	Gamma	Λ λ	Lambda	T τ	Tau
Δ δ	Delta	M μ	Mu	Υ υ	Upsilon
E ε	Epsilon	N ν	Nu	Φ φ	Phi
Z ζ	Zeta	Ξ ξ	Xi	X χ	Chi
H η	Eta	O ο	Omicron	Ψ ψ	Psi
Θ θ	Theta	Π π	Pi	Ω ω	Omega

Γ γ *di-gamma*

Ϟ ϟ *Koppa*

CHAPTER II

CARTESIAN COÖRDINATES

16. Directed line. Let $X'X$ be an indefinite straight line, and let a point O , which we shall call the **origin** be chosen upon it. Let a unit of length be adopted and assume that lengths measured from O to the right are *positive*, and to the left *negative*.

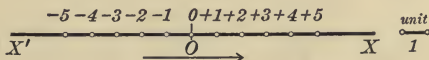

Then any *real* number (p. 1), if taken as the measure of the length of a line OP , will determine a point P on the line. Conversely, to each point P on the line will correspond a real number, namely, the measure of the length OP , with a positive or negative sign according as P is to the right or left of the origin.

The direction established upon $X'X$ by passing from the origin to the points corresponding to the positive numbers is called the **positive direction** on the line. A **directed line** is a straight line upon

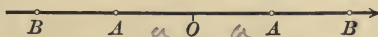

which an origin, a unit of length, and a positive direction have been assumed.

An arrowhead is usually placed upon a directed line to indicate the positive direction.

If A and B are any two points of a directed line such that

$$OA = a, \quad OB = b,$$

then the length of the segment AB is always given by $b - a$; that is, the length of AB is the difference of the numbers corresponding to B and A . This statement is evidently equivalent to the following definition:

For all positions of two points A and B on a directed line, the length AB is given by

$$(1) \quad AB = OB - OA,$$

where O is the origin.

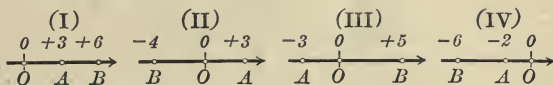

Illustrations.

In Fig. I. $AB = OB - OA = 6 - 3 = +3$; $BA = OA - OB = 3 - 6 = -3$;

II. $AB = OB - OA = -4 - 3 = -7$; $BA = OA - OB = 3 - (-4) = +7$;

III. $AB = OB - OA = +5 - (-3) = +8$; $BA = OA - OB = -3 - 5 = -8$;

IV. $AB = OB - OA = -6 - (-2) = -4$; $BA = OA - OB = -2 - (-6) = +4$.

The following properties of lengths on a directed line are obvious:

$$(2) \quad AB = -BA.$$

(3) AB is positive if the direction from A to B agrees with the positive direction on the line, and negative if in the contrary direction.

The phrase "distance between two points" should not be used if these points lie upon a directed line. Instead, we speak of the length AB , remembering that the lengths AB and BA are *not* equal, but that $AB = -BA$.

17. Cartesian* coördinates. Let $X'X$ and $Y'Y$ be two directed

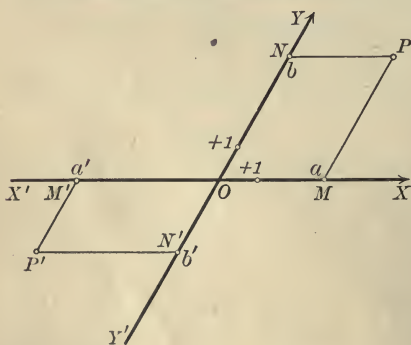

lines intersecting at O , and let P be any point in their plane. Draw lines through P parallel to $X'X$ and $Y'Y$ respectively. Then, if

$$OM = a, \quad ON = b,$$

the numbers a, b are called the **Cartesian coördinates** of P , a the **abscissa** and b the **ordinate**. The directed lines $X'X$ and $Y'Y$ are called the

* So called after René Descartes, 1596-1650, who first introduced the idea of coördinates into the study of Geometry.

axes of coördinates, $X'X$ the axis of abscissas, $Y'Y$ the axis of ordinates, and their intersection O the origin.

The coördinates a, b of P are written (a, b) , and the symbol $P(a, b)$ is to be read: "The point P , whose coördinates are a and b ."

Any point P in the plane determines two numbers, the coördinates of P . Conversely, given two real numbers a' and b' , then a point P' in the plane may always be constructed whose coördinates are (a', b') . For lay off $OM' = a'$, $ON' = b'$, and draw lines parallel to the axes through M' and N' . These lines intersect at $P'(a', b')$. Hence

Every point determines a pair of real numbers, and conversely, a pair of real numbers determines a point.

The imaginary numbers of Algebra have no place in this representation, and for this reason elementary Analytic Geometry is concerned only with the real numbers of Algebra.

18. Rectangular coördinates. A rectangular system of coördinates is determined when the axes $X'X$ and $Y'Y$ are perpendicular

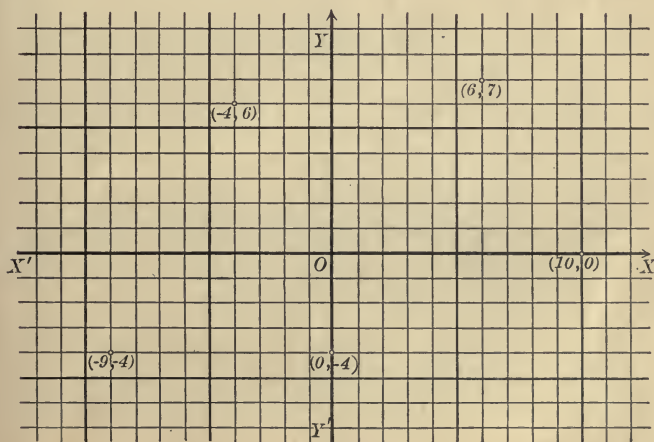

to each other. This is the usual case, and will be assumed unless otherwise stated.

The work of plotting points in a rectangular system is much simplified by the use of *coördinate* or *plotting paper*, constructed by ruling off the plane into equal squares, the sides being parallel to the axes.

In the figure, p. 25, several points are plotted, the unit of length being assumed equal to one division on each axis. The method is simply this:

Count off from O along $X'X$ a number of divisions equal to the given abscissa, and then from the point so determined a number of divisions equal to the given ordinate, observing the

Rule for signs:

Abscissas are positive or negative according as they are laid off to the right or left of the origin. Ordinates are positive or negative according as they are laid off above or below the axis of x .

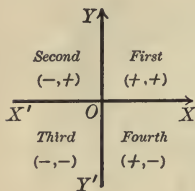

Rectangular axes divide the plane into four portions called *quadrants*; these are numbered as in the figure, in which the proper signs of the coördinates are also indicated.

PROBLEMS

- Plot accurately the points $(3, 2)$, $(3, -2)$, $(-4, 3)$, $(6, 0)$, $(-5, 0)$, $(0, 4)$.
- Plot accurately the points $(1, 6)$, $(3, -2)$, $(-2, 0)$, $(4, -3)$, $(-7, -4)$, $(-2, 4)$, $(0, -1)$, $(\sqrt{3}, \sqrt{2})$, $(-\sqrt{5}, 0)$.
- What are the coördinates of the origin? *Ans.* $(0, 0)$.
- In what quadrants do the following points lie if a and b are positive numbers: $(-a, b)$? $(-a, -b)$? $(b, -a)$? (a, b) ?
- To what quadrants is a point limited if its abscissa is positive? negative? its ordinate is positive? negative?
- Plot the triangle whose vertices are $(2, -1)$, $(-2, 5)$, $(-8, -4)$.
- Plot the triangle whose vertices are $(-2, 0)$, $(5\sqrt{3} - 2, 5)$, $(-2, 10)$.
- Plot the quadrilateral whose vertices are $(0, -2)$, $(4, 2)$, $(0, 6)$, $(-4, 2)$.

9. If a point moves parallel to the axis of x , which of its coördinates remains constant? if parallel to the axis of y ?

10. Can a point move if its abscissa is zero? Where? Can it move if its ordinate is zero? Where? Can it move if both abscissa and ordinate are zero? Where will it be?

11. Where may a point be found if its abscissa is 2? if its ordinate is -3 ?

12. Where do all those points lie whose abscissas and ordinates are equal?

13. Two sides of a rectangle of lengths a and b coincide with the axes of x and y respectively. What are the coördinates of the vertices of the rectangle if it lies in the first quadrant? in the second quadrant? in the third quadrant? in the fourth quadrant?

14. Construct the quadrilateral whose vertices are $(-3, 6)$, $(-3, 0)$, $(3, 0)$, $(3, 6)$. What kind of a quadrilateral is it?

15. Join $(3, 5)$ and $(-3, -5)$; also $(3, -5)$ and $(-3, 5)$. What are the coördinates of the point of intersection of the two lines?

16. Show that (x, y) and $(x, -y)$ are symmetrical with respect to $X'X$; (x, y) and $(-x, y)$ with respect to $Y'Y$; and (x, y) and $(-x, -y)$ with respect to the origin.

17. A line joining two points is bisected at the origin. If the coördinates of one end are $(a, -b)$, what will be the coördinates of the other end?

18. Consider the bisectors of the angles between the coördinate axes. What is the relation between the abscissa and ordinate of any point of the bisector in the first and third quadrants? second and fourth quadrants?

19. A square whose side is $2a$ has its center at the origin. What will be the coördinates of its vertices if the sides are parallel to the axes? if the diagonals coincide with the axes?

$$\text{Ans. } (a, a), (a, -a), (-a, -a), (-a, a); \\ (a\sqrt{2}, 0), (-a\sqrt{2}, 0), (0, a\sqrt{2}), (0, -a\sqrt{2}).$$

20. An equilateral triangle whose side is a has its base on the axis of x and the opposite vertex above $X'X$. What are the vertices of the triangle if the center of the base is at the origin? if the lower left-hand vertex is at the origin?

$$\text{Ans. } \left(\frac{a}{2}, 0\right), \left(-\frac{a}{2}, 0\right), \left(0, \frac{a\sqrt{3}}{2}\right); \\ (0, 0), (a, 0), \left(\frac{a}{2}, \frac{a\sqrt{3}}{2}\right).$$

19. Angles. The angle between two intersecting directed lines is defined to be the angle made by their positive directions. In the figures the angle between the directed lines is the angle marked θ .

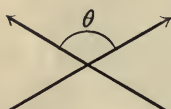

If the directed lines are parallel, then the angle between them is zero or π according as the positive directions agree or do not agree.

Evidently the angle between two directed lines may have any value from 0 to π inclusive.

Reversing the direction of either directed line changes θ to the supplement $\pi - \theta$. If both directions are reversed, the angle is unchanged.

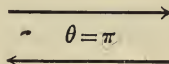
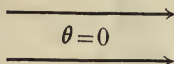

When it is desired to assign a positive direction to a line intersecting $X'X$, we shall always assume the *upward direction* as *positive* (see figures).

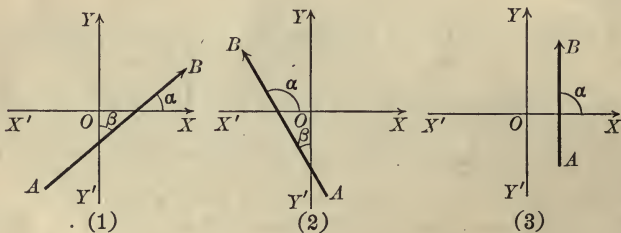

Theorem I. If α and β are the angles between a line directed upward and the rectangular axes OX and OY , then

$$(I) \quad \cos \beta = \sin \alpha.$$

Proof. The figures are typical of all possible cases.

In Fig. 1,
$$\beta = \frac{\pi}{2} - \alpha,$$

and hence
$$\cos \beta = \cos \left(\frac{\pi}{2} - \alpha \right) = \sin \alpha. \quad (\text{by 6, p. 20})$$

In Fig. 2, $\beta = \alpha - \frac{\pi}{2},$

and hence $\cos \beta = \cos \left(\alpha - \frac{\pi}{2} \right) = \sin \alpha.$
(by 4 and 6, p. 19)

In Fig. 3, $\alpha = \frac{\pi}{2}, \beta = 0.$

$\therefore \cos \beta = 1 = \sin \alpha.$ Q. E. D.

The positive direction of a line parallel to $X'X$ will be assumed to agree with the positive direction of $X'X$, that is, to the right. Hence for such a line $\alpha = 0, \beta = \frac{\pi}{2}$, and the relation (I) still holds, since

$$\cos \beta = \cos \frac{\pi}{2} = 0 = \sin 0 = \sin \alpha.$$

PROBLEMS

1. Show that for lines directed downward $\cos \beta = -\sin \alpha.$
2. What are the values of α and β for a line directed N.E. ? N.W. ? S.E. ? S.W. ? (The axes are assumed to indicate the four cardinal points of the compass.)
3. Find the relation between the α 's and β 's of two perpendicular lines directed upward.
Ans. $\alpha' - \alpha = \frac{\pi}{2}; \beta' + \beta = \frac{\pi}{2}.$

20. Orthogonal projection. The orthogonal projection of a point upon a line is the foot of the perpendicular let fall from the point upon the line.

Thus in the figure

M is the orthogonal projection of P on $X'X$;
 N is the orthogonal projection of P on $Y'Y$;
 P' is the orthogonal projection of P' on $X'X$.

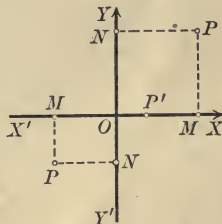

If A and B are two points of a directed line, and M and N their projections upon a second directed line CD , then MN is called the projection of AB upon CD .

Theorem II. First theorem of projection. *If A and B are points upon a directed line making an angle γ with a second directed line CD , then the*

(II) **projection of the length AB upon $CD = AB \cos \gamma$.**

Proof. In the figures let

a = the numerical length of AB ,

l = the numerical length of AS or BT ;

then a and l are positive numbers giving the lengths of the respective lines, as in Plane Geometry. Now apply the definition of the cosine to the right triangles ABS and ABT (p. 18).

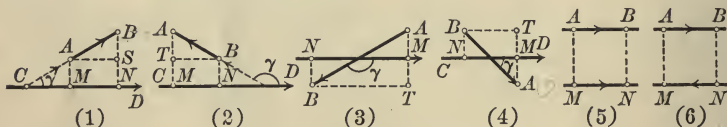

In Fig. 1,

$$l = a \cos BAS = a \cos \gamma,$$

$$MN = l, \quad AB = a.$$

$$\therefore MN = AB \cos \gamma.$$

In Fig. 2,

$$l = a \cos ABT = a \cos (\pi - \gamma)$$

$$= -a \cos \gamma,$$

(by 5, p. 20)

$$MN = l, \quad AB = -a.$$

$$\therefore MN = AB \cos \gamma.$$

In Fig. 3,

$$l = a \cos ABT = a \cos (\pi - \gamma)$$

$$= -a \cos \gamma,$$

$$MN = -l, \quad AB = a.$$

$$\therefore MN = AB \cos \gamma.$$

In Fig. 4,

$$l = a \cos ABT = a \cos \gamma,$$

$$MN = -l, \quad AB = -a.$$

$$\therefore MN = AB \cos \gamma.$$

In Fig. 5,

$$\gamma = 0, \quad MN = l, \quad AB = a.$$

Hence

$$MN = AB = AB \cos 0 \text{ (since } \cos 0 = 1 \text{)}.$$

$$\therefore MN = AB \cos \gamma.$$

In Fig. 6,

$$\gamma = \pi, \quad MN = -l, \quad AB = a.$$

Hence

$$MN = -AB = AB \cos \pi \text{ (since } \cos \pi = -1 \text{)}.$$

$$\therefore MN = AB \cos \gamma.$$

Consider any two given points

$$P_1(x_1, y_1), P_2(x_2, y_2).$$

Then in the figure

$M_1M_2 =$ projection of P_1P_2 on $X'X$,

$N_1N_2 =$ projection of P_1P_2 on $Y'Y$.

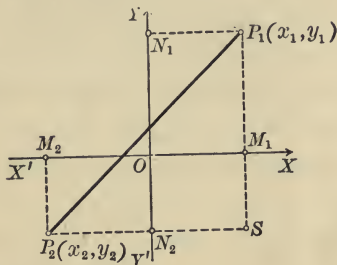

But by (1), p. 24,

$$M_1M_2 = OM_2 - OM_1 = x_2 - x_1,$$

$$N_1N_2 = ON_2 - ON_1 = y_2 - y_1.$$

Hence

Theorem III. *Given any two points $P_1(x_1, y_1), P_2(x_2, y_2)$; then*

$$(III) \quad \begin{cases} x_2 - x_1 = \text{projection of } P_1P_2 \text{ on } X'X; \\ y_2 - y_1 = \text{projection of } P_1P_2 \text{ on } Y'Y. \end{cases}$$

21. Lengths. We may now easily prove the important

Theorem IV. *The length l of the line joining two points $P_1(x_1, y_1), P_2(x_2, y_2)$ is given by the formula*

$$(IV) \quad l = \sqrt{(x_1 - x_2)^2 + (y_1 - y_2)^2}.$$

Proof. Draw lines through P_1 and P_2 parallel to the axes to form the right triangle P_1SP_2 .

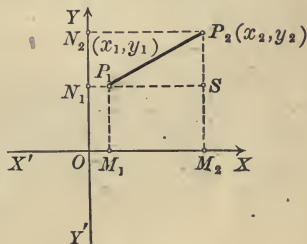

Then

$$SP_1 = M_2M_1 = x_1 - x_2, \quad (\text{by III})$$

$$P_2S = N_2N_1 = y_1 - y_2, \quad (\text{by III})$$

$$P_1P_2 = \sqrt{P_2S^2 + SP_1^2};$$

and hence

$$l = \sqrt{(x_1 - x_2)^2 + (y_1 - y_2)^2}.$$

Q.E.D.

The method used in deriving (IV) for *any* positions of P_1 and P_2 is the following:

Construct a right triangle by drawing lines parallel to the axes through P_1 and P_2 . The sides of this triangle are equal to the projections of the length P_1P_2 upon the axes. But these projections are always given by (III), or by (III) with one or both signs changed. The required length is then the square root of the sum of the *squares* of these projections, so that the change in sign mentioned may be neglected. A number of different figures should be drawn to make the method clear.

Ex. 1. Find the length of the line joining the points $(1, 3)$ and $(-5, 5)$.

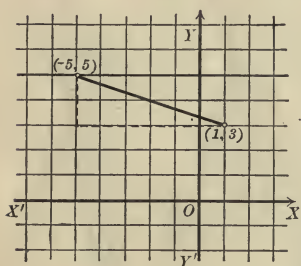

Solution. Call $(1, 3)$ P_1 , and $(-5, 5)$ P_2 .

Then

$$x_1 = 1, y_1 = 3, \text{ and } x_2 = -5, y_2 = 5;$$

and substituting in (IV), we have

$$l = \sqrt{(1 + 5)^2 + (3 - 5)^2} = \sqrt{40} = 2\sqrt{10}.$$

It should be noticed that we are simply finding the hypotenuse of a right triangle whose sides are 6 and 2.

Remark. The fact that formulas (III) and (IV) are true for *all* positions of the points P_1 and P_2 is of fundamental importance. The application of these formulas to any given problem is therefore simply a matter of direct substitution, as the example worked out above illustrates. In deriving such general formulas, since it is immaterial in what quadrants the assumed points lie, it is most convenient to draw the figure so that the points lie in the first quadrant, or, in general, so that *all the quantities assumed as known shall be positive.*

PROBLEMS

1. Find the projections on the axes and the length of the lines joining the following points:

(a) $(-4, -4)$ and $(1, 3)$. *Ans.* Projections 5, 7; length = $\sqrt{74}$.

(b) $(-\sqrt{2}, \sqrt{3})$ and $(\sqrt{3}, \sqrt{2})$.

Ans. Projections $\sqrt{3} + \sqrt{2}$, $\sqrt{2} - \sqrt{3}$; length = $\sqrt{10}$.

(c) $(0, 0)$ and $\left(\frac{a}{2}, \frac{a\sqrt{3}}{2}\right)$. *Ans.* Projections $\frac{a}{2}, \frac{a}{2}\sqrt{3}$; length = a .

(d) $(a + b, c + a)$ and $(c + a, b + c)$.

Ans. Projections $c - b, b - a$; length = $\sqrt{(b - c)^2 + (a - b)^2}$.

2. Find the projections of the sides of the following triangles upon the axes:

(a) $(0, 6), (1, 2), (3, -5)$.

(b) $(1, 0), (-1, -5), (-1, -8)$.

(c) $(a, b), (b, c), (c, d)$.

3. Find the lengths of the sides of the triangles in problem 2.

4. Work out formulas (III) and (IV), (a) if $x_1 = x_2$; (b) if $y_1 = y_2$.

5. Find the lengths of the sides of the triangle whose vertices are $(4, 3), (2, -2), (-3, 5)$.

6. Show that the points $(1, 4), (4, 1), (5, 5)$ are the vertices of an isosceles triangle.

7. Show that the points $(2, 2), (-2, -2), (2\sqrt{3}, -2\sqrt{3})$ are the vertices of an equilateral triangle.

8. Show that $(3, 0), (6, 4), (-1, 3)$ are the vertices of a right triangle. What is its area?

9. Prove that $(-4, -2), (2, 0), (8, 6), (2, 4)$ are the vertices of a parallelogram. Also find the lengths of the diagonals.

10. Show that $(11, 2), (6, -10), (-6, -5), (-1, 7)$ are the vertices of a square. Find its area.

11. Show that the points $(1, 3), (2, \sqrt{6}), (2, -\sqrt{6})$ are equidistant from the origin, that is, show that they lie on a circle with its center at the origin and its radius $\sqrt{10}$.

12. Show that the diagonals of any rectangle are equal.

13. Find the perimeter of the triangle whose vertices are $(a, b), (-a, b), (-a, -b)$.

14. Find the perimeter of the polygon formed by joining the following points two by two in order:

$(6, 4), (4, -3), (0, -1), (-5, -4), (-2, 1)$.

15. One end of a line whose length is 13 is the point $(-4, 8)$; the ordinate of the other end is 3. What is its abscissa? *Ans.* 8 or -16.

16. What equation must the coördinates of the point (x, y) satisfy if its distance from the point $(7, -2)$ is equal to 11?

17. What equation expresses algebraically the fact that the point (x, y) is equidistant from the points $(2, 3)$ and $(4, 5)$?

18. If the angle XOY (Fig., p. 24) equals ω , show that the length of the line joining $P_1(x_1, y_1)$ and $P_2(x_2, y_2)$ is given by

$$l = \sqrt{(x_1 - x_2)^2 + (y_1 - y_2)^2 + 2(x_1 - x_2)(y_1 - y_2)\cos\omega}.$$

19. If $\omega = \frac{\pi}{3}$, find distance between the points $(-3, 3)$ and $(4, -2)$.

Ans. $\sqrt{39}$.

20. If $\omega = \frac{\pi}{3}$, find the perimeter of the triangle whose vertices are $(1, 3)$, $(2, 7)$, $(-4, -4)$.

Ans. $\sqrt{21} + \sqrt{223} + \sqrt{109}$.

21. If $\omega = \frac{\pi}{6}$, find the perimeter of triangle $(1, 2)$, $(-2, -4)$, $(3, -5)$.

Ans. $3\sqrt{5 + 2\sqrt{3}} + \sqrt{26 - 5\sqrt{3}} + \sqrt{53 - 14\sqrt{3}}$.

22. Prove that $(6, 6)$, $(7, -1)$, $(0, -2)$, $(-2, 2)$ lie on a circle whose center is at $(3, 2)$.

23. If $\omega = \frac{3\pi}{4}$, find the distance between $(\sqrt{3}, \sqrt{2})$, $(-\sqrt{2}, \sqrt{3})$.

Ans. $\sqrt{10 + \sqrt{2}}$.

24. Show that the sum of the projections of the sides of a polygon upon either axis is zero if each side is given a direction established by passing continuously around the perimeter.

22. Inclination and slope. The inclination of a line is the angle between the axis of x and the line when the latter is given the upward direction (p. 28).

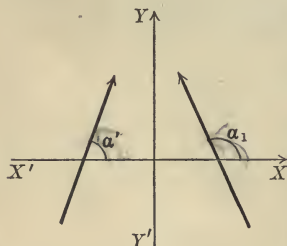

The slope of a line is the tangent of its inclination.

The inclination of a line will be denoted by $\alpha, \alpha_1, \alpha_2, \alpha'$, etc.; its slope by m, m_1, m_2, m' , etc., so that $m = \tan \alpha$, $m_1 = \tan \alpha_1$, etc.

The inclination may be any angle from 0 to π inclusive (p. 28). The slope may be any real number, since the tangent of an angle in the first two quadrants may be any number positive or negative. The slope of a line parallel to $X'X$ is of course zero, since the inclination is 0 or π . For a line parallel to $Y'Y$ the slope is infinite.

Theorem V. *The slope m of the line passing through two points $P_1(x_1, y_1), P_2(x_2, y_2)$ is given by*

$$(V) \quad m = \frac{y_2 - y_1}{x_2 - x_1}$$

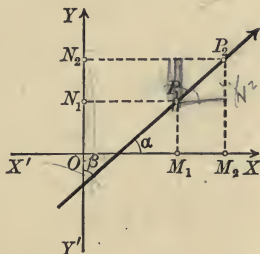

Proof. $M_1M_2 = x_2 - x_1$ (by (III), p. 31)
 $= P_1P_2 \cos \alpha$ (by (II), p. 30)

$$(1) \quad \therefore P_1P_2 \cos \alpha = x_2 - x_1.$$

Similarly, $N_1N_2 = y_2 - y_1$ (by (III), p. 31)
 $= P_1P_2 \cos \beta$ (by (II), p. 30)

$$(2) \quad \therefore P_1P_2 \cos \beta = y_2 - y_1.$$

But $\cos \beta = \sin \alpha$ (by (I), p. 28)

Hence, from (2),

$$(3) \quad P_1P_2 \sin \alpha = y_2 - y_1.$$

Dividing (3) by (1), $\tan \alpha = m = \frac{y_2 - y_1}{x_2 - x_1} = \frac{y_2 - y_1}{x_2 - x_1}$. Q. E. D.

Remark. Formula (V) may be verified by constructing a right triangle whose hypotenuse is P_1P_2 , as on p. 31, whence $\tan \alpha$ ($= \tan \angle SP_1P_2$) is found directly as the ratio of the opposite side, $SP_2 = y_2 - y_1$, to the adjacent side, $P_1S = x_2 - x_1$.*

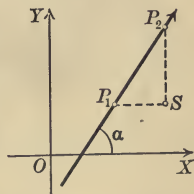

* To construct a line passing through a given point P_1 whose slope is a positive fraction $\frac{a}{b}$, we mark a point S b units to the right of P_1 and a point P_2 a units above S , and draw P_1P_2 . If the slope is a negative fraction, $-\frac{a}{b}$, then either S must lie to the left of P_1 or P_2 must lie below S .

Theorem VI. *If two lines are parallel, their slopes are equal; if perpendicular, the slope of one is the negative reciprocal of the slope of the other, and conversely.*

Proof. Let α_1 and α_2 be the inclinations and m_1 and m_2 the slopes of the lines.

If the lines are parallel, $\alpha_1 = \alpha_2$. $\therefore m_1 = m_2$.

If the lines are perpendicular, as in the figure,

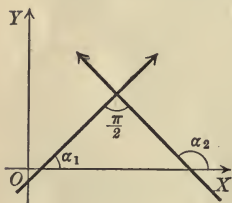

$$\alpha_2 = \alpha_1 + \frac{\pi}{2}, \text{ or } \alpha_1 = \alpha_2 - \frac{\pi}{2}.$$

$$\therefore m_1 = \tan \alpha_1 = \tan \left(\alpha_2 - \frac{\pi}{2} \right)$$

$$= -\cot \alpha_2 \quad (\text{by 4 and 6, p. 19})$$

$$= -\frac{1}{\tan \alpha_2} \quad (\text{by 1, p. 19})$$

$$\therefore m_1 = -\frac{1}{m_2} \quad \text{Q. E. D.}$$

The converse is proved by retracing the steps with the assumption, in the second part, that α_2 is greater than α_1 .

PROBLEMS

1. Find the slope of the line joining (1, 3) and (2, 7). Ans. 4.

2. Find the slope of the line joining (2, 7) and (-4, -4). Ans. $\frac{11}{6}$.

3. Find the slope of the line joining $(\sqrt{3}, \sqrt{2})$ and $(-\sqrt{2}, \sqrt{3})$.
Ans. $2\sqrt{6} - 5$.

4. Find the slope of the line joining $(a + b, c + a)$, $(c + a, b + c)$.
Ans. $\frac{b - a}{c - b}$.

5. Find the slopes of the sides of the triangle whose vertices are (1, 1), (-1, -1), $(\sqrt{3}, -\sqrt{3})$.
Ans. $1, \frac{1 + \sqrt{3}}{1 - \sqrt{3}}, \frac{1 - \sqrt{3}}{1 + \sqrt{3}}$.

6. Prove by means of slopes that (-4, -2), (2, 0), (8, 6), (2, 4) are the vertices of a parallelogram.

7. Prove by means of slopes that (3, 0), (6, 4), (-1, 3) are the vertices of a right triangle.

8. Prove by means of slopes that (0, -2), (4, 2), (0, 6), (-4, 2) are the vertices of a rectangle, and hence, by (IV), of a square.

9. Prove by means of their slopes that the diagonals of the square in problem 8 are perpendicular.

10. Prove by means of slopes that $(10, 0)$, $(5, 5)$, $(5, -5)$, $(-5, 5)$ are the vertices of a trapezoid.

11. Show that the line joining (a, b) and $(c, -d)$ is parallel to the line joining $(-a, -b)$ and $(-c, d)$.

12. Show that the line joining the origin to (a, b) is perpendicular to the line joining the origin to $(-b, a)$.

13. What is the inclination of a line parallel to $Y'Y$? perpendicular to $Y'Y$?

14. What is the slope of a line parallel to $Y'Y$? perpendicular to $Y'Y$?

15. What is the inclination of the line joining $(2, 2)$ and $(-2, -2)$?

$$\text{Ans. } \frac{\pi}{4}.$$

16. What is the inclination of the line joining $(-2, 0)$ and $(-5, 3)$?

$$\text{Ans. } \frac{3\pi}{4}.$$

17. What is the inclination of the line joining $(3, 0)$ and $(4, \sqrt{3})$?

$$\text{Ans. } \frac{\pi}{3}.$$

18. What is the inclination of the line joining $(3, 0)$ and $(2, \sqrt{3})$?

$$\text{Ans. } \frac{2\pi}{3}.$$

19. What is the inclination of the line joining $(0, -4)$ and $(-\sqrt{3}, -5)$?

$$\text{Ans. } \frac{\pi}{6}.$$

20. What is the inclination of the line joining $(0, 0)$ and $(-\sqrt{3}, 1)$?

$$\text{Ans. } \frac{5\pi}{6}.$$

21. Prove by means of slopes that $(2, 3)$, $(1, -3)$, $(3, 9)$ lie on the same straight line.

22. Prove that the points $(a, b+c)$, $(b, c+a)$, and $(c, a+b)$ lie on the same straight line.

23. Prove that $(1, 5)$ is on the line joining the points $(0, 2)$ and $(2, 8)$ and is equidistant from them.

24. Prove that the line joining $(3, -2)$ and $(5, 1)$ is perpendicular to the line joining $(10, 0)$ and $(13, -2)$.

23. Point of division. Let P_1 and P_2 be two fixed points on a directed line. Any third point on the line, as P or P' , is said

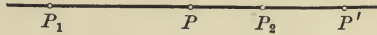

“to divide the line into two segments,” and is called a **point of division**. The division is called **internal** or **external** according as the point falls within or without P_1P_2 . The position of the point of division depends upon the *ratio* of its distances from P_1 and P_2 . Since, however, the line is directed, some convention must be made as to the manner of reading these distances. We therefore adopt the rule:

If P is a point of division on a directed line passing through P_1 and P_2 , then P is said to divide P_1P_2 into the segments P_1P and PP_2 . The **ratio of division** is the value of the ratio* $\frac{P_1P}{PP_2}$.

We shall denote this ratio by λ , that is,

$$\lambda = \frac{P_1P}{PP_2}.$$

If the division is internal, P_1P and PP_2 agree in direction and therefore in sign, and λ is therefore positive. In external division λ is negative. The *sign* of λ therefore indicates whether the point of division P is within or without the segment P_1P_2 ; and the *numerical value* determines whether P lies nearer P_1 or P_2 . The distribution of λ is indicated in the figure.

$$\frac{-1 < \lambda < 0 \quad \lambda = 0 \quad \lambda > 0 \quad \lambda = \infty \quad -\infty < \lambda < -1}{P_1 \qquad \qquad \qquad P_2}$$

That is, λ may have any positive value between P_1 and P_2 , any negative value between 0 and -1 to the left of P_1 , and any negative value between -1 and $-\infty$ to the right of P_2 . The value -1 for λ is excluded.

*To assist the memory in writing down this ratio, notice that the point of division P is written *last* in the numerator and *first* in the denominator.

Introducing coördinates, we next prove

Theorem VII. Point of division. *The coördinates (x, y) of the point of division P on the line joining $P_1(x_1, y_1), P_2(x_2, y_2)$, such that the ratio of the segments is*

$$\frac{P_1P}{PP_2} = \lambda,$$

are given by the formulas

$$(VII) \quad x = \frac{x_1 + \lambda x_2}{1 + \lambda}, \quad y = \frac{y_1 + \lambda y_2}{1 + \lambda}.$$

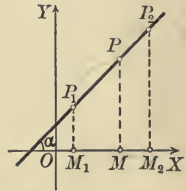

Proof. Given $\lambda = \frac{P_1P}{PP_2}.$

Let α be the inclination of the line P_1P_2 . Project P_1, P, P_2 upon the axis of x .

Then, by the first theorem of projection [(II), p. 30],

$$M_1M = P_1P \cos \alpha,$$

$$MM_2 = PP_2 \cos \alpha.$$

Dividing, $\frac{M_1M}{MM_2} = \frac{P_1P}{PP_2} = \lambda.$ (by hypothesis)

But $M_1M = x - x_1,$
 $MM_2 = x_2 - x.$ (by (III), p. 31)

Substituting, $\frac{x - x_1}{x_2 - x} = \lambda.$

Clearing of fractions and solving for $x,$

$$x = \frac{x_1 + \lambda x_2}{1 + \lambda}.$$

Similarly,

$$y = \frac{y_1 + \lambda y_2}{1 + \lambda}.$$

Q.E.D.

Corollary. Middle point. *The coördinates (x, y) of the middle point of the line joining $P_1(x_1, y_1), P_2(x_2, y_2)$ are found by taking the averages of the given abscissas and ordinates; that is,*

$$x = \frac{1}{2}(x_1 + x_2), \quad y = \frac{1}{2}(y_1 + y_2).$$

For if P is the middle point of P_1P_2 , then $\lambda = \frac{P_1P}{PP_2} = 1.$

Ex. 1. Find the point P dividing $P_1(-1, -6)$, $P_2(3, 0)$ in the ratio $\lambda = -\frac{1}{4}$.

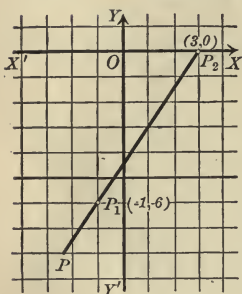

Solution. Applying (VII), $x_1 = -1$, $y_1 = -6$,
 $x_2 = 3$, $y_2 = 0$.

$$\therefore x = \frac{-1 - \frac{1}{4} \cdot 3}{1 - \frac{1}{4}} = \frac{-\frac{7}{4}}{\frac{3}{4}} = -2\frac{1}{3},$$

$$y = \frac{-6 - \frac{1}{4} \cdot 0}{1 - \frac{1}{4}} = \frac{-6}{\frac{3}{4}} = -8.$$

Hence P is $(-2\frac{1}{3}, -8)$. *Ans.*

Ex. 2. Find the coördinates of the point of intersection of the medians of a triangle whose vertices are (x_1, y_1) , (x_2, y_2) , (x_3, y_3) .

Solution. By Plane Geometry we have to find the point P on the median AD such that $AP = \frac{2}{3} AD$, that is, $AP : PD :: 2 : 1$, or $\lambda = 2$.

By the Corollary, D is $[\frac{1}{2}(x_2 + x_3), \frac{1}{2}(y_2 + y_3)]$.

To find P , apply (VII), remembering that A corresponds to (x_1, y_1) and D to (x_2, y_2) .

$$\text{This gives } x = \frac{x_1 + 2 \cdot \frac{1}{2}(x_2 + x_3)}{1 + 2},$$

$$y = \frac{y_1 + 2 \cdot \frac{1}{2}(y_2 + y_3)}{1 + 2}.$$

$$\therefore x = \frac{1}{3}(x_1 + x_2 + x_3), \quad y = \frac{1}{3}(y_1 + y_2 + y_3). \quad \text{Ans.}$$

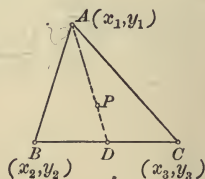

Hence the abscissa of the intersection of the medians of a triangle is the average of the abscissas of the vertices, and similarly for the ordinate.

The *symmetry* of these answers is evidence that the particular median chosen is immaterial, and the *formulas therefore prove the fact of the intersection of the medians*.

PROBLEMS

- Find the coördinates of the middle point of the line joining $(4, -6)$ and $(-2, -4)$. *Ans.* $(1, -5)$.
- Find the coördinates of the middle point of the line joining $(a+b, c+d)$ and $(a-b, d-c)$. *Ans.* (a, d) .
- Find the middle points of the sides of the triangle whose vertices are $(2, 3)$, $(4, -5)$, and $(-3, -6)$; also find the lengths of the medians.
- Find the coördinates of the point which divides the line joining $(-1, 4)$ and $(-5, -8)$ in the ratio $1 : 3$. *Ans.* $(-2, 1)$.
- Find the coördinates of the point which divides the line joining $(-3, -5)$ and $(6, 9)$ in the ratio $2 : 5$. *Ans.* $(-\frac{3}{7}, -1)$.

6. Find the coördinates of the point which divides the line joining (2, 6) and (-4, 8) into segments whose ratio is $-\frac{4}{3}$. *Ans.* (-22, 14).

7. Find the coördinates of the point which divides the line joining (-3, -4) and (5, 2) into segments whose ratio is $-\frac{2}{3}$. *Ans.* (-19, -16).

8. Find the coördinates of the points which trisect the line joining the points (-2, -1) and (3, 2). *Ans.* $(-\frac{1}{3}, 0)$, $(\frac{4}{3}, 1)$.

9. Prove that the middle point of the hypotenuse of a right triangle is equidistant from the three vertices.

10. Show that the diagonals of the parallelogram whose vertices are (1, 2), (-5, -3), (7, -6), (1, -11) bisect each other.

11. Prove that the diagonals of any parallelogram mutually bisect each other.

12. Show that the lines joining the middle points of the opposite sides of the quadrilateral whose vertices are (6, 8), (-4, 0), (-2, -6), (4, -4) bisect each other.

13. In the quadrilateral of problem 12 show by means of slopes that the lines joining the middle points of the adjacent sides form a parallelogram.

14. Show that in the trapezoid whose vertices are (-8, 0), (-4, -4), (-4, 4), and (4, -4) the length of the line joining the middle points of the non-parallel sides is equal to one half the sum of the lengths of the parallel sides. Also prove that it is parallel to the parallel sides.

15. In what ratio does the point (-2, 3) divide the line joining the points (-3, 5) and (4, -9)? *Ans.* $\frac{1}{6}$.

16. In what ratio does the point (16, 3) divide the line joining the points (-5, 0) and (2, 1)? *Ans.* $-\frac{3}{2}$.

17. Given the triangle whose vertices are (-5, 3), (1, -3), (7, 5); show that a line joining the middle points of any two sides is parallel to the third side and equal to one half of it.

18. If (2, 1), (3, 3), (6, 2) are the middle points of the sides of a triangle, what are the coördinates of the vertices of the triangle?

Ans. (-1, 2), (5, 0), (7, 4).

19. Three vertices of a parallelogram are (1, 2), (-5, -3), (7, -6). What are the coördinates of the fourth vertex?

Ans. (1, -11), (-11, 5), or (13, -1).

20. The middle point of a line is (6, 4), and one end of the line is (5, 7). What are the coördinates of the other end? *Ans.* (7, 1).

21. The vertices of a triangle are (2, 3), (4, -5), (-3, -6). Find the coördinates of the point where the medians intersect (center of gravity).

22. Find the area of the isosceles triangle whose vertices are $(1, 5)$, $(5, 1)$, $(-9, -9)$ by finding the lengths of the base and altitude.

23. A line AB is produced to C so that $BC = \frac{1}{2} AB$. If the points A and B have the coördinates $(5, 6)$ and $(7, 2)$ respectively, what are the coördinates of C ? Ans. $(8, 0)$.

24. Show that formula (VII) holds for oblique coördinates, that is, $\angle XOY$ may have any value.

25. How far is the point bisecting the line joining the points $(5, 5)$ and $(3, 7)$ from the origin? What is the slope of this last line? Ans. $2\sqrt{13}, \frac{3}{2}$.

24. Areas. In this section the problem of determining the area of any polygon the coördinates of whose vertices are given will be solved. We begin with

Theorem VIII. *The area of a triangle whose vertices are the origin, $P_1(x_1, y_1)$, and $P_2(x_2, y_2)$ is given by the formula*

$$(VIII) \quad \text{Area of triangle } OP_1P_2 = \frac{1}{2}(x_1y_2 - x_2y_1).$$

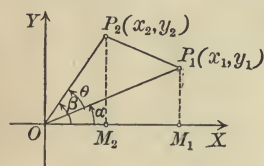

Proof. In the figure let

$$\alpha = \angle XOP_1,$$

$$\beta = \angle XOP_2,$$

$$\theta = \angle P_1OP_2.$$

$$(1) \quad \therefore \theta = \beta - \alpha.$$

By 18, p. 20,

$$(2) \quad \text{Area } \triangle OP_1P_2 = \frac{1}{2} OP_1 \cdot OP_2 \sin \theta$$

$$= \frac{1}{2} OP_1 \cdot OP_2 \sin(\beta - \alpha) \quad [\text{by (1)}]$$

$$(3) \quad = \frac{1}{2} OP_1 \cdot OP_2 (\sin \beta \cos \alpha - \cos \beta \sin \alpha).$$

(by 9, p. 20)

But in the figure

$$\sin \beta = \frac{M_2P_2}{OP_2} = \frac{y_2}{OP_2}, \quad \cos \beta = \frac{OM_2}{OP_2} = \frac{x_2}{OP_2},$$

$$\sin \alpha = \frac{M_1P_1}{OP_1} = \frac{y_1}{OP_1}, \quad \cos \alpha = \frac{OM_1}{OP_1} = \frac{x_1}{OP_1}.$$

Substituting in (3) and reducing, we obtain

$$\text{Area } \triangle OP_1P_2 = \frac{1}{2}(x_1y_2 - x_2y_1).$$

Q.E.D.

Ex. 1. Find the area of the triangle whose vertices are the origin, $(-2, 4)$, and $(-5, -1)$.

Solution. Denote $(-2, 4)$ by P_1 , $(-5, -1)$ by P_2 .

Then

$$x_1 = -2, y_1 = 4, x_2 = -5, y_2 = -1.$$

Substituting in (VIII),

$$\text{Area} = \frac{1}{2}[-2 \cdot -1 - (-5) \cdot 4] = 11.$$

Then Area = 11 unit squares.

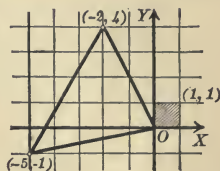

If, however, the formula (VIII) is applied by denoting $(-2, 4)$ by P_2 , and $(-5, -1)$ by P_1 , the result will be -11 .

The two figures are as follows :

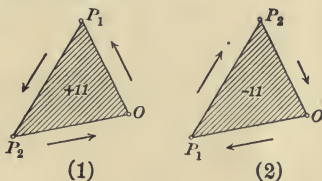

The cases of *positive* and *negative* area are distinguished by

Theorem IX. *Passing around the perimeter in the order of the vertices O, P_1, P_2 ,*

if the area is on the left, as in Fig. 1, then (VIII) gives a positive result;

if the area is on the right, as in Fig. 2, then (VIII) gives a negative result.

Proof. When the area is on the left as in Fig. 1, then in (1), p. 42, we have $\beta > \alpha$, and hence θ is positive. Therefore $\sin \theta$ is positive and the product in (2), p. 42, which gives the area of OP_1P_2 , is also positive. But when the area is on the right, as in Fig. 2, we have $\beta < \alpha$, and hence θ is negative. Then $\sin \theta$ is negative, and hence also the product in (2), p. 42, which gives the area of OP_1P_2 .

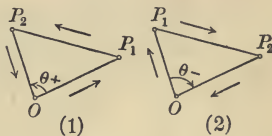

Q. E. D.

Formula (VIII) is easily applied to any polygon by regarding its area as made up of triangles with the origin as a common vertex. Consider any triangle.

Theorem X. *The area of a triangle whose vertices are $P_1(x_1, y_1)$, $P_2(x_2, y_2)$, $P_3(x_3, y_3)$ is given by*

$$(X) \quad \text{Area } \triangle P_1P_2P_3 = \frac{1}{2}(x_1y_2 - x_2y_1 + x_2y_3 - x_3y_2 + x_3y_1 - x_1y_3).$$

This formula gives a positive or negative result according as the area lies to the left or right in passing around the perimeter in the order $P_1P_2P_3$.

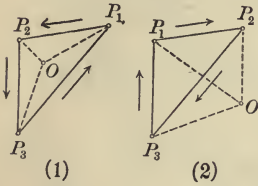

Proof. Two cases must be distinguished according as the origin is within or without the triangle.

Fig. 1, origin within the triangle.

By inspection,

$$(5) \quad \text{Area } \triangle P_1P_2P_3 = \triangle OP_1P_2 + \triangle OP_2P_3 + \triangle OP_3P_1,$$

since these areas all have the same sign.

Fig. 2, origin without the triangle. By inspection,

$$(6) \quad \text{Area } \triangle P_1P_2P_3 = \triangle OP_1P_2 + \triangle OP_2P_3 + \triangle OP_3P_1,$$

since OP_1P_2 , OP_3P_1 have the same sign, but OP_2P_3 the opposite sign, the algebraic sum giving the desired area.

By (VIII), $\triangle OP_1P_2 = \frac{1}{2}(x_1y_2 - x_2y_1)$,

$$\triangle OP_2P_3 = \frac{1}{2}(x_2y_3 - x_3y_2), \quad \triangle OP_3P_1 = \frac{1}{2}(x_3y_1 - x_1y_3).$$

Substituting in (5) and (6), we have (X).

Also in (5) the area is positive, in (6) negative.

Q.E.D.

An easy way to apply (X) is given by the following

Rule for finding the area of a triangle.

First step. Write down the vertices in two columns, abscissas in one, ordinates in the other, repeating the coördinates of the first vertex.

x_1	\cdot	y_1
x_2		y_2
x_3		y_3
x_1		y_1

Second step. Multiply each abscissa by the ordinate of the next row, and add results. This gives $x_1y_2 + x_2y_3 + x_3y_1$.

Third step. Multiply each ordinate by the abscissa of the next row, and add results. This gives $y_1x_2 + y_2x_3 + y_3x_1$.

Fourth step. Subtract the result of the third step from that of the second step, and divide by 2. This gives the required area, namely, formula (X).

It is easy to show in the same manner that the rule applies to any polygon, if the following caution be observed in the first step :

Write down the coördinates of the vertices in an order agreeing with that established by passing continuously around the perimeter, and repeat the coördinates of the first vertex.

Ex. 2. Find the area of the quadrilateral whose vertices are (1, 6), (-3, -4), (2, -2), (-1, 3).

Solution. Plotting, we have the figure from which we choose the *order* of the vertices as indicated by the arrows. Following the rule :

First step. Write down the vertices in order.

1	6
-1	3
-3	-4
2	-2
1	6

Second step. Multiply each abscissa by the ordinate of the next row, and add. This gives

$$1 \times 3 + (-1 \times -4) + (-3 \times -2) + 2 \times 6 = 25.$$

Third step. Multiply each ordinate by the abscissa of the next row and add. This gives

$$6 \times -1 + 3 \times -3 + (-4 \times 2) + (-2 \times 1) = -25.$$

Fourth step. Subtract the result of the third step from the result of the second step, and divide by 2.

$$\therefore \text{Area} = \frac{25 + 25}{2} = 25 \text{ unit squares. } \text{Ans.}$$

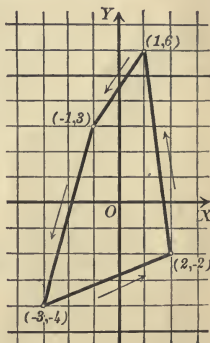

The result has the positive sign, since the area is on the *left*.

PROBLEMS

1. Find the area of the triangle whose vertices are (2, 3), (1, 5), (-1, -2).
Ans. $\frac{11}{2}$.

2. Find the area of the triangle whose vertices are (2, 3), (4, -5), (-3, -6).
Ans. 29.

3. Find the area of the triangle whose vertices are (8, 3), (-2, 3), (4, -5).
Ans. 40.

4. Find the area of the triangle whose vertices are (a, 0), (-a, 0), (0, b).
Ans. ab.

5. Find the area of the triangle whose vertices are (0, 0), (x₁, y₁), (x₂, y₂).
Ans. $\frac{x_1 y_2 - x_2 y_1}{2}$.

6. Find the area of the triangle whose vertices are $(a, 1)$, $(0, b)$, $(c, 1)$.

$$\text{Ans. } \frac{(a-c)(b-1)}{2}$$

7. Find the area of the triangle whose vertices are (a, b) , (b, a) , $(c, -c)$.

$$\text{Ans. } \frac{1}{2}(a^2 - b^2)$$

8. Find the area of the triangle whose vertices are $(3, 0)$, $(0, 3\sqrt{3})$, $(6, 3\sqrt{3})$.

$$\text{Ans. } 9\sqrt{3}$$

9. Prove that the area of the triangle whose vertices are the points $(2, 3)$, $(5, 4)$, $(-4, 1)$ is zero, and hence that these points all lie on the same straight line.

10. Prove that the area of the triangle whose vertices are the points $(a, b+c)$, $(b, c+a)$, $(c, a+b)$ is zero, and hence that these points all lie on the same straight line.

11. Prove that the area of the triangle whose vertices are the points $(a, c+a)$, $(-c, 0)$, $(-a, c-a)$ is zero, and hence that these points all lie on the same straight line.

12. Find the area of the quadrilateral whose vertices are $(-2, 3)$, $(-3, -4)$, $(5, -1)$, $(2, 2)$.

$$\text{Ans. } 31$$

13. Find the area of the pentagon whose vertices are $(1, 2)$, $(3, -1)$, $(6, -2)$, $(2, 5)$, $(4, 4)$.

$$\text{Ans. } 18$$

14. Find the area of the parallelogram whose vertices are $(10, 5)$, $(-2, 5)$, $(-5, -3)$, $(7, -3)$.

$$\text{Ans. } 96$$

15. Find the area of the quadrilateral whose vertices are $(0, 0)$, $(5, 0)$, $(9, 11)$, $(0, 3)$.

$$\text{Ans. } 41$$

16. Find the area of the quadrilateral whose vertices are $(7, 0)$, $(11, 9)$, $(0, 5)$, $(0, 0)$.

$$\text{Ans. } 59$$

17. Show that the area of the triangle whose vertices are $(4, 6)$, $(2, -4)$, $(-4, 2)$ is four times the area of the triangle formed by joining the middle points of the sides.

18. Show that the lines drawn from the vertices $(3, -8)$, $(-4, 6)$, $(7, 0)$ to the medial point of the triangle divide it into three triangles of equal area.

19. Given the quadrilateral whose vertices are $(0, 0)$, $(6, 8)$, $(10, -2)$, $(4, -4)$; show that the area of the quadrilateral formed by joining the middle points of its adjacent sides is equal to one half the area of the given quadrilateral.

25. Second theorem of projection.

Lemma I. *If M_1, M_2, M_3 are any three points on a directed line, then in all cases*

$$M_1M_3 = M_1M_2 + M_2M_3.$$

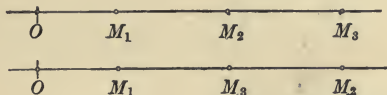

Proof. Let O be the origin.

By (1), p. 24, $M_1M_2 = OM_2 - OM_1,$

$$M_2M_3 = OM_3 - OM_2.$$

Adding, $M_1M_2 + M_2M_3 = OM_3 - OM_1.$

But by (1), p. 24, $M_1M_3 = OM_3 - OM_1.$

$$\therefore M_1M_3 = M_1M_2 + M_2M_3.$$

Q.E.D.

This result is easily extended to prove

Lemma II. *If $M_1, M_2, M_3, \dots, M_{n-1}, M_n$ are any n points on a directed line, then in all cases*

$$M_1M_n = M_1M_2 + M_2M_3 + M_3M_4 + \dots + M_{n-1}M_n,$$

the lengths in the right-hand member being so written that the second point of each length is the first point of the next.

The line joining the first and last points of a broken line is called the closing line.

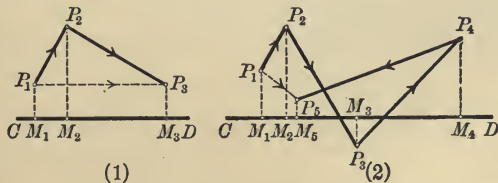

Thus in Fig. 1 the closing line is P_1P_3 ; in Fig. 2 the closing line is P_1P_5 .

Theorem XI. Second theorem of projection. *If each segment of a broken line be given the direction determined in passing continuously from one extremity to the other, then the algebraic sum of the projections of the segments upon any directed line equals the projection of the closing line.*

Proof. The proof results immediately from the Lemmas. For in Fig. 1

$$M_1M_2 = \text{projection of } P_1P_2;$$

$$M_2M_3 = \text{projection of } P_2P_3;$$

$$M_1M_3 = \text{projection of closing line } P_1P_3.$$

But by Lemma I

$$M_1M_2 + M_2M_3 = M_1M_3,$$

and the theorem follows.

Similarly in Fig. 2.

Q. E. D.

Corollary. *If the sides of a closed polygon be given the direction established by passing continuously around the perimeter, the sum of the projections of the sides upon any directed line is zero.*

For the closing line is now zero.

Ex. 1. Find the projection of the line joining the origin and $(5, 3)$ upon a line passing through $(-5, 0)$ whose inclination is $\frac{\pi}{4}$.

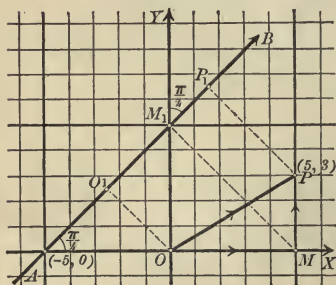

Solution. In the figure, applying the second theorem of projection,

$$\begin{aligned} \text{proj. of } OP \text{ on } AB & \\ &= \text{proj. of } OM + \text{proj. of } MP \\ &= OM \cos \frac{\pi}{4} + MP \cos \frac{\pi}{4} \end{aligned}$$

(by first theorem of projection, p. 30)

$$= \frac{5}{2} \sqrt{2} + \frac{3}{2} \sqrt{2} = 4 \sqrt{2}. \text{ Ans.}$$

The essential point in the solution of problems like Ex. 1 is the replacing of the given line, by means of Theorem XI, by a broken line with two segments which are parallel to the axes.

Ex. 2. Find the perpendicular distance from the line passing through $(4, 0)$, whose inclination is $\frac{2\pi}{3}$, to the point $(10, 2)$.

Solution. In the figure draw OC perpendicular to the given line AB .

$$\angle XAS = \frac{2\pi}{3}, \text{ or } 120^\circ.$$

$$\therefore \angle XOS = 30^\circ, \angle SOY = 60^\circ.$$

Required the perpendicular distance RP .

Project the broken line OMP upon OC . Then, by the second theorem of projection,

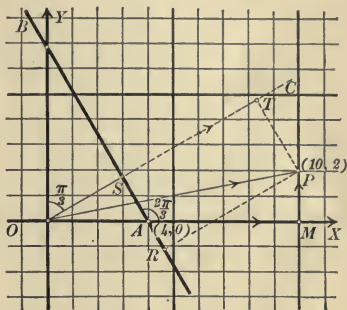

$$\begin{aligned} \text{proj. of } OP &= \text{proj. of } OM + \text{proj. of } MP \\ &= OM \cos \angle XOS + MP \cos \angle SOY \\ &= 10 \cdot \frac{1}{2} \sqrt{3} + 2 \cdot \frac{1}{2} \\ &= 1 + 5\sqrt{3}. \end{aligned}$$

(1) But in the figure

$$\begin{aligned} \text{proj. of } OP &= OS + ST \\ &= OA \cos XOS + RP \\ &= 4 \cdot \frac{1}{2} \sqrt{3} + RP. \end{aligned}$$

(2) From (1) and (2),

$$\begin{aligned} RP + 2\sqrt{3} &= 1 + 5\sqrt{3}. \\ RP &= 1 + 3\sqrt{3}. \quad \text{Ans.} \end{aligned}$$

PROBLEMS

1. Four points lie on the axis of abscissas at distances of 1, 3, 6, and 10 respectively from the origin. Find P_1P_4 by Lemma II.

2. A broken line joins continuously the points $(-1, 4)$, $(3, 6)$, $(6, -2)$, $(8, 1)$, $(1, -1)$. Show that the second theorem of projection holds when the segments are projected on the X -axis.

3. Show by means of a figure that the projection of the broken line joining the points $(1, 2)$, $(5, 4)$, $(-1, -4)$, $(3, -1)$, and $(1, 2)$ upon any line is zero.

4. Find the projection of the line joining the points $(2, 1)$ and $(5, 3)$ upon a line passing through the point $(-1, 1)$ whose inclination is $\frac{\pi}{6}$.

$$\text{Ans. } \frac{3\sqrt{3} + 2}{2}.$$

5. What is the projection of the line joining these same points upon any line whose inclination is $\frac{\pi}{6}$? Why?

6. Find the projection of the line joining the points $(-1, 3)$ and $(2, 4)$ upon any line whose inclination is $\frac{3}{4}\pi$. *Ans.* $-\sqrt{2}$.

7. Find the projection of the broken line joining the points $(-1, 4)$, $(3, 6)$, and $(5, 0)$ upon a line whose inclination is $\frac{\pi}{4}$. Verify your result by finding the projection of the closing line. *Ans.* $\sqrt{2}$.

8. Find the projection of the broken line joining $(0, 0)$, $(4, 2)$, and $(6, -3)$ upon a line whose inclination is $\frac{2\pi}{3}$. *Ans.* $\frac{-6 - 3\sqrt{3}}{2}$.

9. Show that the projection of the sides of the triangle $(2, 1)$, $(-1, 5)$, $(-3, 1)$ upon a line whose inclination is $\frac{\pi}{6}$ is zero.

10. Find the perpendicular distance from the point $(6, 3)$ to a line passing through the point $(-4, 0)$ with an inclination of $\frac{\pi}{4}$. *Ans.* $\frac{7}{\sqrt{2}}$.

11. Find the perpendicular distance from the point $(-5, -1)$ to a line passing through the point $(6, 0)$ and having an inclination of $\frac{3}{4}\pi$. *Ans.* $6\sqrt{2}$.

12. A line of inclination $\frac{\pi}{6}$ passes through the point $(5, 0)$. Find the perpendicular distance to the parallel line passing through the point $(0, 2)$. *Ans.* $\frac{5 + 2\sqrt{3}}{2}$.

CHAPTER III

THE CURVE AND THE EQUATION

26. Locus of a point satisfying a given condition. The curve* (or group of curves) passing through all points which satisfy a given condition, and through no other points, is called the locus of the point satisfying that condition.

For example, in Plane Geometry, the following results are proved:

The perpendicular bisector of the line joining two fixed points is the locus of all points equidistant from these points.

The bisectors of the adjacent angles formed by two lines is the locus of all points equidistant from these lines.

To solve any locus problem involves two things:

1. To draw the locus by constructing a sufficient number of points satisfying the given condition and therefore lying on the locus.

2. To discuss the nature of the locus, that is, to determine properties of the curve.†

Analytic Geometry is peculiarly adapted to the solution of both parts of a locus problem.

27. Equation of the locus of a point satisfying a given condition. Let us take up the locus problem, making use of coördinates. If any point P satisfying the given condition and therefore lying on the locus be given the coördinates (x, y) , then the given condition will lead to an equation involving the variables x and y . The following example illustrates this fact, which is of fundamental importance.

* The word "curve" will hereafter signify *any continuous line*, straight or curved.

† As the only loci considered in Elementary Geometry are straight lines and circles, the complete loci may be constructed by ruler and compasses, and the second part is relatively unimportant.

Ex. 1. Find the equation in x and y if the point whose locus is required shall be equidistant from $A(-2, 0)$ and $B(-3, 8)$.

Solution. Let $P(x, y)$ be any point on the locus. Then by the given condition

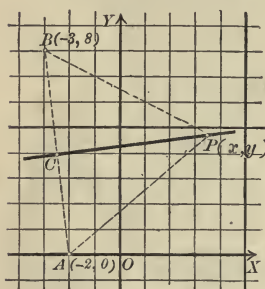

$$(1) \quad PA = PB.$$

But, by formula IV, p. 31,

$$PA = \sqrt{(x+2)^2 + (y-0)^2},$$

$$PB = \sqrt{(x+3)^2 + (y-8)^2}.$$

Substituting in (1),

$$(2) \quad \sqrt{(x+2)^2 + (y-0)^2} \\ = \sqrt{(x+3)^2 + (y-8)^2}.$$

Squaring and reducing,

$$(3) \quad 2x - 16y + 69 = 0.$$

In the equation (3), x and y are *variables* representing the coördinates of any point on the locus, that is, of any point on the perpendicular bisector of the line AB . This equation has two important and characteristic properties:

1. The coördinates of any point on the locus may be substituted for x and y in the equation (3), and the result will be true.

For let $P_1(x_1, y_1)$ be any point on the locus. Then $P_1A = P_1B$, by definition. Hence, by formula IV, p. 31,

$$(4) \quad \sqrt{(x_1+2)^2 + y_1^2} = \sqrt{(x_1+3)^2 + (y_1-8)^2},$$

or, squaring and reducing,

$$(5) \quad 2x_1 - 16y_1 + 69 = 0.$$

Therefore x_1 and y_1 satisfy (3).

2. Conversely, every point whose coördinates satisfy (3) will lie upon the locus.

For if $P_1(x_1, y_1)$ is a point whose coördinates satisfy (3), then (5) is true, and hence also (4) holds. Q. E. D.

In particular, the coördinates of the middle point C of A and B , namely, $x = -2\frac{1}{2}$, $y = 4$ (Corollary, p. 39), satisfy (3), since $2(-2\frac{1}{2}) - 16 \times 4 + 69 = 0$.

This example illustrates the following *correspondence* between Pure and Analytic Geometry as regards the locus problem:

Locus problem

Pure Geometry

The geometrical condition (satisfied by every point on the locus).

Analytic Geometry

An equation in the variables x and y representing coördinates (satisfied by the coördinates of every point on the locus).

This discussion leads to the fundamental definition :

The **equation of the locus** of a point satisfying a given condition is an equation in the variables x and y representing coördinates such that (1) the coördinates of every point on the locus will satisfy the equation; and (2) conversely, every point whose coördinates satisfy the equation will lie upon the locus.

This definition shows that the equation of the locus must be tested *in two ways* after derivation, as illustrated in the example of this section and in those following.

From the above definition follows at once the

Corollary. *A point lies upon a curve when and only when its coördinates satisfy the equation of the curve.*

28. First fundamental problem. *To find the equation of a curve which is defined as the locus of a point satisfying a given condition.*

The following rule will suffice for the solution of this problem in many cases :

Rule. *First step.* Assume that $P(x, y)$ is any point satisfying the given condition and is therefore on the curve.

Second step. Write down the given condition.

Third step. Express the given condition in coördinates and simplify the result. The final equation, containing x, y , and the given constants of the problem, will be the required equation.

Ex. 1. Find the equation of the straight line passing through $P_1(4, -1)$ and having an inclination of $\frac{3\pi}{4}$.

Solution. First step. Assume $P(x, y)$ any point on the line.

Second step. The given condition, since the inclination α is $\frac{3\pi}{4}$, may be written

$$(1) \quad \text{Slope of } P_1P = \tan \alpha = -1.$$

Third step. From (V), p. 35,

$$(2) \quad \text{Slope of } P_1P = \tan \alpha = \frac{y_1 - y_2}{x_1 - x_2} = \frac{y + 1}{x - 4}.$$

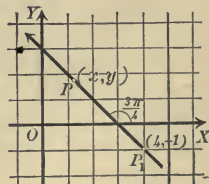

[By substituting (x, y) for (x_1, y_1) , and $(4, -1)$ for (x_2, y_2) .]

$$\therefore \text{ from (1), } \quad \frac{y+1}{x-4} = -1,$$

or

$$(3) \quad x + y - 3 = 0. \quad \text{Ans.}$$

To prove that (3) is the required equation :

1. The coördinates (x_1, y_1) of any point on the line will satisfy (3), for the line joins (x_1, y_1) and $(4, -1)$, and its slope is -1 ; hence, by (V), p. 35, substituting $(4, -1)$ for (x_2, y_2) ,

$$-1 = \frac{y_1 + 1}{x_1 - 4}, \text{ or } x_1 + y_1 - 3 = 0,$$

and therefore x_1 and y_1 satisfy the equation (3).

2. Conversely, any point whose coördinates satisfy (3) is a point on the straight line. For if (x_1, y_1) is any such point, that is, if $x_1 + y_1 - 3 = 0$, then also $-1 = \frac{y_1 + 1}{x_1 - 4}$ is true, and (x_1, y_1) is a point on the line passing through $(4, -1)$ and having an inclination equal to $\frac{3\pi}{4}$. Q. E. D.

Ex. 2. Find the equation of a straight line parallel to the axis of y and at a distance of 6 units to the right.

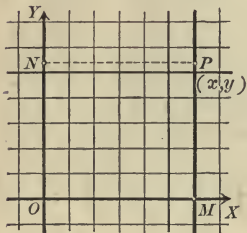

Solution. First step. Assume that $P(x, y)$ is any point on the line, and draw NP perpendicular to OY .

Second step. The given condition may be written

$$(4) \quad NP = 6.$$

Third step. Since $NP = OM = x$, (4) becomes

$$(5) \quad x = 6. \quad \text{Ans.}$$

The equation (5) is the required equation :

1. The coördinates of every point satisfying the given condition may be substituted in (5). For if $P_1(x_1, y_1)$ is any such point, then by the given condition $x_1 = 6$, that is, (x_1, y_1) satisfies (5).

2. Conversely, if the coördinates (x_1, y_1) satisfy (5), then $x_1 = 6$, and $P_1(x_1, y_1)$ is at a distance of six units to the right of YY' . Q. E. D.

The method above illustrated of proving that the derived equation has the two characteristic properties of the equation of the locus should be carefully studied and applied to each of the following examples.

Ex. 3. Find the equation of the locus of a point whose distance from $(-1, 2)$ is always equal to 4.

Solution. First step. Assume that $P(x, y)$ is any point on the locus.

Second step. Denoting $(-1, 2)$ by C , the given condition is

$$(6) \quad PC = 4.$$

Third step. By formula (IV), p. 31,

$$PC = \sqrt{(x+1)^2 + (y-2)^2}.$$

Substituting in (6),

$$\sqrt{(x+1)^2 + (y-2)^2} = 4.$$

Squaring and reducing,

$$(7) \quad x^2 + y^2 + 2x - 4y - 11 = 0.$$

This is the required equation, namely, the equation of the circle whose center is $(-1, 2)$ and radius equals 4. The method of proof is the same as that of the preceding examples.

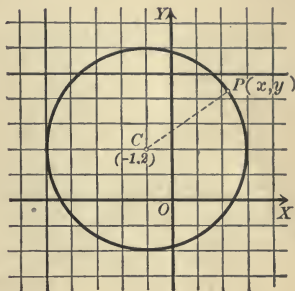

PROBLEMS

- Find the equation of a line parallel to OY and
 - at a distance of 4 units to the right.
 - at a distance of 7 units to the left.
 - at a distance of 2 units to the right of $(3, 2)$.
 - at a distance of 5 units to the left of $(2, -2)$.
- What is the equation of a line parallel to OY and $a - b$ units from it? How does this line lie relative to OY if $a > b > 0$? if $0 > b > a$?
- Find the equation of a line parallel to OX and
 - at a distance of 3 units above OX .
 - at a distance of 6 units below OX .
 - at a distance of 7 units above $(-2, -3)$.
 - at a distance of 5 units below $(4, -2)$.
- What is the equation of XX' ? of YY' ?
- Find the equation of a line parallel to the line $x = 4$ and 3 units to the right of it. Eight units to the left of it.
- Find the equation of a line parallel to the line $y = -2$ and 4 units below it. Five units above it.
- How does the line $y = a - b$ lie if $a > b > 0$? if $b > a > 0$?
- What is the equation of the axis of x ? of the axis of y ?

9. What is the equation of the locus of a point which moves always at a distance of 2 units from the axis of x ? from the axis of y ? from the line $x = -5$? from the line $y = 4$?

10. What is the equation of the locus of a point which moves so as to be equidistant from the lines $x = 5$ and $x = 9$? equidistant from $y = 3$ and $y = -7$?

11. What are the equations of the sides of the rectangle whose vertices are $(5, 2)$, $(5, 5)$, $(-2, 2)$, $(-2, 5)$?

In problems 12 and 13, P_1 is a given point on the required line, m is the slope of the line, and α its inclination.

12. What is the equation of a line if

- | | |
|-------------------------------------------------------|----------------------------------------------------|
| (a) P_1 is $(0, 3)$ and $m = -3$? | <i>Ans.</i> $3x + y - 3 = 0$. |
| (b) P_1 is $(-4, -2)$ and $m = \frac{1}{3}$? | <i>Ans.</i> $x - 3y - 2 = 0$. |
| (c) P_1 is $(-2, 3)$ and $m = \frac{\sqrt{2}}{2}$? | <i>Ans.</i> $\sqrt{2}x - 2y + 6 + 2\sqrt{2} = 0$. |
| (d) P_1 is $(0, 5)$ and $m = \frac{\sqrt{3}}{2}$? | <i>Ans.</i> $\sqrt{3}x - 2y + 10 = 0$. |
| (e) P_1 is $(0, 0)$ and $m = -\frac{3}{2}$? | <i>Ans.</i> $2x + 3y = 0$. |
| (f) P_1 is (a, b) and $m = 0$? | <i>Ans.</i> $y = b$. |
| (g) P_1 is $(-a, b)$ and $m = \infty$? | <i>Ans.</i> $x = -a$. |

13. What is the equation of a line if

- | | |
|-----------------------------------------------------------|---------------------------------------------------|
| (a) P_1 is $(2, 3)$ and $\alpha = 45^\circ$? | <i>Ans.</i> $x - y + 1 = 0$. |
| (b) P_1 is $(-1, 2)$ and $\alpha = 45^\circ$? | <i>Ans.</i> $x - y + 3 = 0$. |
| (c) P_1 is $(-a, -b)$ and $\alpha = 45^\circ$? | <i>Ans.</i> $x - y = b - a$. |
| (d) P_1 is $(5, 2)$ and $\alpha = 60^\circ$? | <i>Ans.</i> $\sqrt{3}x - y + 2 - 5\sqrt{3} = 0$. |
| (e) P_1 is $(0, -7)$ and $\alpha = 60^\circ$? | <i>Ans.</i> $\sqrt{3}x - y - 7 = 0$. |
| (f) P_1 is $(-4, 5)$ and $\alpha = 0^\circ$? | <i>Ans.</i> $y = 5$. |
| (g) P_1 is $(2, -3)$ and $\alpha = 90^\circ$? | <i>Ans.</i> $x = 2$. |
| (h) P_1 is $(3, -3\sqrt{3})$ and $\alpha = 120^\circ$? | <i>Ans.</i> $\sqrt{3}x + y = 0$. |
| (i) P_1 is $(0, 3)$ and $\alpha = 150^\circ$? | <i>Ans.</i> $\sqrt{3}x + 3y - 9 = 0$. |
| (j) P_1 is (a, b) and $\alpha = 135^\circ$? | <i>Ans.</i> $x + y = a + b$. |

14. Are the points $(3, 9)$, $(4, 6)$, $(5, 5)$ on the line $3x + 2y = 25$?

15. Find the equation of the circle with

- | | |
|----------------------------------------------|--------------------------------------------------------------------|
| (a) center at $(3, 2)$ and radius = 4. | <i>Ans.</i> $x^2 + y^2 - 6x - 4y - 3 = 0$. |
| (b) center at $(12, -5)$ and $r = 13$. | <i>Ans.</i> $x^2 + y^2 - 24x + 10y = 0$. |
| (c) center at $(0, 0)$ and radius = r . | <i>Ans.</i> $x^2 + y^2 = r^2$. |
| (d) center at $(0, 0)$ and $r = 5$. | <i>Ans.</i> $x^2 + y^2 = 25$. |
| (e) center at $(3a, 4a)$ and $r = 5a$. | <i>Ans.</i> $x^2 + y^2 - 2a(3x + 4y) = 0$. |
| (f) center at $(b + c, b - c)$ and $r = c$. | <i>Ans.</i> $x^2 + y^2 - 2(b + c)x - 2(b - c)y + 2b^2 + c^2 = 0$. |

16. Find the equation of a circle whose center is $(5, -4)$ and whose circumference passes through the point $(-2, 3)$.

17. Find the equation of a circle having the line joining $(3, -5)$ and $(-2, 2)$ as a diameter.

✓ 18. Find the equation of a circle touching each axis at a distance 6 units from the origin.

19. Find the equation of a circle whose center is the middle point of the line joining $(-6, 8)$ to the origin and whose circumference passes through the point $(2, 3)$.

20. A point moves so that its distances from the two fixed points $(2, -3)$ and $(-1, 4)$ are equal. Find the equation of the locus and plot.

$$\text{Ans. } 3x - 7y + 2 = 0.$$

21. Find the equation of the perpendicular bisector of the line joining

(a) $(2, 1)$, $(-3, -3)$.

$$\text{Ans. } 10x + 8y + 13 = 0$$

(b) $(3, 1)$, $(2, 4)$.

$$\text{Ans. } x - 3y + 5 = 0.$$

(c) $(-1, -1)$, $(3, 7)$.

$$\text{Ans. } x + 2y - 7 = 0.$$

(d) $(0, 4)$, $(3, 0)$.

$$\text{Ans. } 6x - 8y + 7 = 0.$$

(e) (x_1, y_1) , (x_2, y_2) .

$$\text{Ans. } 2(x_1 - x_2)x + 2(y_1 - y_2)y + x_2^2 - x_1^2 + y_2^2 - y_1^2 = 0.$$

22. Show that in problem 21 the coordinates of the middle point of the line joining the given points satisfy the equation of the perpendicular bisector.

23. Find the equations of the perpendicular bisectors of the sides of the triangle $(4, 8)$, $(10, 0)$, $(6, 2)$. Show that they meet in the point $(11, 7)$.

24. Express by an equation that the point (h, k) is equidistant from $(-1, 1)$ and $(1, 2)$; also from $(1, 2)$ and $(1, -2)$. Then show that the point $(\frac{3}{2}, 0)$ is equidistant from $(-1, 1)$, $(1, 2)$, $(1, -2)$.

29. **General equations of the straight line and circle.** The methods illustrated in the preceding section enable us to state the following results:

1. A straight line parallel to the axis of y has an equation of the form $x = \text{constant}$.

2. A straight line parallel to the axis of x has an equation of the form $y = \text{constant}$.

Theorem I. *The equation of the straight line passing through a point $B(0, b)$ on the axis of y and having its slope equal to m is*

$$(I) \quad y = mx + b.$$

Proof. First step. Assume that $P(x, y)$ is any point on the line.

Second step. The given condition may be written

$$\text{Slope of } PB = m.$$

Third step. Since by Theorem V, p. 35,

$$\text{Slope of } PB = \frac{y - b}{x - 0},$$

[Substituting (x, y) for (x_1, y_1) and $(0, b)$ for (x_2, y_2)]

then
$$\frac{y - b}{x} = m, \text{ or } y = mx + b.$$

Q. E. D.

Theorem II. *The equation of the circle whose center is a given point (α, β) and whose radius equals r is*

$$(II) \quad x^2 + y^2 - 2\alpha x - 2\beta y + \alpha^2 + \beta^2 - r^2 = 0.$$

Proof. First step. Assume that $P(x, y)$ is any point on the locus.

Second step. If the center (α, β) be denoted by C , the given condition is

$$PC = r.$$

Third step. By (IV), p. 31,

$$PC = \sqrt{(x - \alpha)^2 + (y - \beta)^2}.$$

$$\therefore \sqrt{(x - \alpha)^2 + (y - \beta)^2} = r.$$

Squaring and transposing, we have (II).

Q. E. D.

Corollary. *The equation of the circle whose center is the origin $(0, 0)$ and whose radius is r is*

$$x^2 + y^2 = r^2.$$

The following facts should be observed :

Any straight line is defined by an equation of the *first degree* in the variables x and y .

Any circle is defined by an equation of the *second degree* in the variables x and y , in which the *terms of the second degree consist of the sum of the squares of x and y .*

30. Locus of an equation. The preceding sections have illustrated the fact that a locus problem in Analytic Geometry leads at once to an equation in the variables x and y . This equation having been found or being given, the complete solution of the locus problem requires two things, as already noted in the first section (p. 51) of this chapter, namely,

1. To draw the locus by plotting a sufficient number of points whose coördinates satisfy the given equation, and through which the locus therefore passes.

2. To discuss the nature of the locus, that is, to determine properties of the curve.

These two problems are respectively called :

1. Plotting the locus of an equation (second fundamental problem).

2. Discussing an equation (third fundamental problem).

For the present, then, we concentrate our attention upon some given equation in the variables x and y (one or both) and start out with the definition :

The **locus of an equation** in two variables representing coördinates is the curve or group of curves passing through all points whose coördinates satisfy that equation,* and through such points only.

From this definition the truth of the following theorem is at once apparent :

Theorem III. *If the form of the given equation be changed in any way (for example, by transposition, by multiplication by a constant, etc.), the locus is entirely unaffected.*

* An equation in the variables x and y is not necessarily satisfied by the coördinates of any points. For coördinates are *real* numbers, and the form of the equation may be such that it is satisfied by no real values of x and y . For example, the equation

$$x^2 + y^2 + 1 = 0$$

is of this sort, since, when x and y are real numbers, x^2 and y^2 are necessarily positive (or zero), and consequently $x^2 + y^2 + 1$ is always a positive number greater than or equal to 1, and therefore *not* equal to zero. Such an equation therefore has *no locus*. The expression "the locus of the equation is imaginary" is also used.

An equation may be satisfied by the coördinates of a *finite* number of points only. For example, $x^2 + y^2 = 0$ is satisfied by $x = 0$, $y = 0$, but by no other real values. In this case the group of points, one or more, whose coördinates satisfy the equation, is called the locus of the equation.

We now take up in order the solution of the second and third fundamental problems.

31. Second fundamental problem.

Rule to plot the locus of a given equation.

*First step. Solve the given equation for one of the variables in terms of the other.**

Second step. By this formula compute the values of the variable for which the equation has been solved by assuming real values for the other variable.

Third step. Plot the points corresponding to the values so determined.†

Fourth step. If the points are numerous enough to suggest the general shape of the locus, draw a smooth curve through the points.

Since there is no limit to the number of points which may be computed in this way, it is evident that the locus may be drawn as *accurately as may be desired* by simply plotting a sufficiently large number of points.

Several examples will now be worked out and the arrangement of the work should be carefully noted.

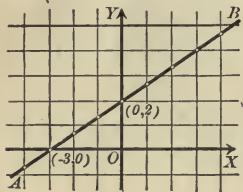

Ex. 1. Draw the locus of the equation

$$2x - 3y + 6 = 0.$$

Solution. First step. Solving for y ,

$$y = \frac{2}{3}x + 2.$$

Second step. Assume values for x and compute y , arranging results in the form :

Thus, if

$$x = 1, \quad y = \frac{2}{3} \cdot 1 + 2 = 2\frac{2}{3},$$

$$x = 2, \quad y = \frac{2}{3} \cdot 2 + 2 = 3\frac{1}{3},$$

etc.

Third step. Plot the points found.

Fourth step. Draw a smooth curve through these points.

x	y	x	y
0	2	0	2
1	$2\frac{2}{3}$	-1	$1\frac{1}{3}$
2	$3\frac{1}{3}$	-2	$\frac{2}{3}$
3	4	-3	0
4	$4\frac{2}{3}$	-4	$-\frac{2}{3}$
etc.	etc.	etc.	etc.

* The form of the given equation will often be such that solving for one variable is simpler than solving for the other. *Always choose the simpler solution.*

† Remember that *real* values only may be used as coördinates.

Ex. 2. Plot the locus of the equation

$$y = x^2 - 2x - 5.$$

Solution. First step. The equation as given is solved for y .

Second step. Computing y by assuming values of x , we find the table of values below :

x	y	x	y
0	-3	0	-3
1	-4	-1	0
2	-3	-2	5
3	0	-3	12
4	5	-4	21
5	12	etc.	etc.
6	21		
etc.	etc.		

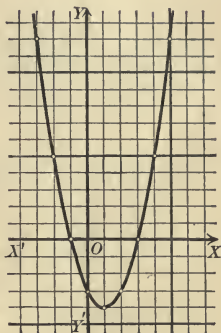

Third step. Plot the points.

Fourth step. Draw a smooth curve through these points. This gives the curve of the figure.

Ex. 3. Plot the locus of the equation

$$x^2 + y^2 + 6x - 16 = 0.$$

First step. Solving for y ,

$$y = \pm \sqrt{16 - 6x - x^2}.$$

Second step. Compute y by assuming values of x .

x	y	x	y
0	± 4	0	± 4
1	± 3	-1	± 4.6
2	0	-2	± 4.9
3	imag.	-3	± 5
4	"	-4	± 4.9
5	"	-5	± 4.6
6	"	-6	± 4
7	"	-7	± 3
		-8	0
		-9	imag.

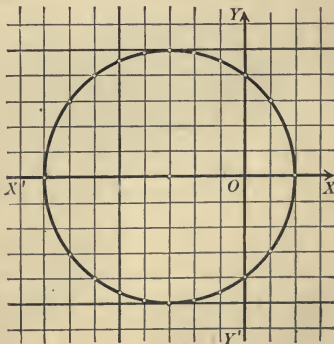

For example, if $x = 1$, $y = \pm \sqrt{16 - 6 - 1} = \pm 3$;

if $x = 3$, $y = \pm \sqrt{16 - 18 - 9} = \pm \sqrt{-11}$,

an imaginary number ;

if $x = -1$, $y = \pm \sqrt{16 + 6 - 1} = \pm 4.6$,

etc.

Third step. Plot the corresponding points.

Fourth step. Draw a smooth curve through these points.

PROBLEMS

1. Plot the locus of each of the following equations.

(a) $x + 2y = 0$.

(p) $x^2 + y^2 = 9$.

(b) $x + 2y = 3$.

(q) $x^2 + y^2 = 25$.

(c) $3x - y + 5 = 0$.

(r) $x^2 + y^2 + 9x = 0$.

(d) $y = 4x^2$.

(s) $x^2 + y^2 + 4y = 0$.

(e) $x^2 + 4y = 0$.

(t) $x^2 + y^2 - 6x - 16 = 0$.

(f) $y = x^2 - 3$.

(u) $x^2 + y^2 - 6y - 16 = 0$.

(g) $x^2 + 4y - 5 = 0$.

(v) $4y = x^2 - 8$.

(h) $y = x^2 + x + 1$.

(w) $4x = y^4 + 8$.

(i) $x = y^2 + 2y - 3$.

(j) $4x = y^3$.

(x) $y = \frac{x}{1 + x^2}$.

(k) $4x = y^3 - 1$.

(y) $x = \frac{1 - y^2}{1 + y^2}$.

(l) $y = x^3 - 1$.

(m) $y = x^3 - x$.

(n) $y = x^3 - x^2 - 5$.

(z) $x = \frac{2}{1 + y^2}$.

(o) $x^2 + y^2 = 4$.

2. Show that the following equations have *no locus* (footnote, p. 59).

(a) $x^2 + y^2 + 1 = 0$.

(f) $x^2 + y^2 + 2x + 2y + 3 = 0$.

(b) $2x^2 + 3y^2 = -8$.

(g) $4x^2 + y^2 + 8x + 5 = 0$.

(c) $x^2 + 4 = 0$.

(h) $y^4 + 2x^2 + 4 = 0$.

(d) $x^4 + y^2 + 8 = 0$.

(i) $9x^2 + 4y^2 + 18x + 8y + 15 = 0$.

(e) $(x + 1)^2 + y^2 + 4 = 0$.

(j) $x^2 + xy + y^2 + 3 = 0$.

Hint. Write each equation in the form of a sum of squares, or solve for one variable and apply Theorem III, p. 11, to the quadratic under the radical.

32. Principle of comparison. In Ex. 1, p. 60, and Ex. 3, p. 61, we can determine the nature of the locus, that is, *discuss the equation*, by making use of the formulas (I) and (II), p. 58. The method is important and is known as the **principle of comparison**.

The nature of the locus of a given equation may be determined by comparison with a general known equation, if the latter becomes identical with the given equation by assigning particular values to its coefficients.

The method of making the comparison is explained in the following

Rule. *First step.* Change the form* of the given equation (if necessary) so that one or more of its terms shall be identical with one or more terms of the general equation.

Second step. Equate coefficients of corresponding terms in the two equations, supplying any terms missing in the given equation with zero coefficients.

Third step. Solve the equations found in the second step for the values† of the coefficients of the general equation.

Ex. 1. Show that $2x - 3y + 6 = 0$ is the equation of a straight line (Fig., p. 60).

Solution. First step. Compare with the general equation (I), p. 58,

$$(1) \quad y = mx + b.$$

Put the given equation in the form of (1) by solving for y ,

$$(2) \quad y = \frac{2}{3}x + 2.$$

Second step. The right-hand members are now identical. Equating coefficients of x ,

$$(3) \quad m = \frac{2}{3}.$$

Equating constant terms,

$$(4) \quad b = 2.$$

Third step. Equations (3) and (4) give the values of the coefficients m and b , and these are possible values, since, p. 34, the slope of a line may have any real value whatever, and of course the ordinate b of the point $(0, b)$ in which a line crosses the Y -axis may also be any real number. Therefore the equation $2x - 3y + 6 = 0$ represents a straight line passing through $(0, 2)$ and having a slope equal to $\frac{2}{3}$. Q.E.D.

* This transformation is called "putting the given equation in the form" of the general equation.

† The values thus found may be impossible (for example, imaginary) values. This may indicate one of two things, — that the given equation has no locus, or that it cannot be put in the form required.

Ex. 2. Show that the locus of

$$(5) \quad x^2 + y^2 + 6x - 16 = 0$$

is a circle (Fig., p. 61).

Solution. First step. Compare with the general equation (II), p. 58,

$$(6) \quad x^2 + y^2 - 2\alpha x - 2\beta y + \alpha^2 + \beta^2 - r^2 = 0.$$

The right-hand members of (5) and (6) agree, and also the first two terms, $x^2 + y^2$.

Second step. Equating coefficients of x ,

$$(7) \quad -2\alpha = 6.$$

Equating coefficients of y ,

$$(8) \quad -2\beta = 0.$$

Equating constant terms,

$$(9) \quad \alpha^2 + \beta^2 - r^2 = -16.$$

Third step. From (7) and (8),

$$\alpha = -3, \beta = 0.$$

Substituting these values in (9) and solving for r , we find

$$r^2 = 25, \text{ or } r = 5.$$

Since α , β , r may be any real numbers whatever, the locus of (5) is a circle whose center is $(-3, 0)$ and whose radius equals 5.

PROBLEMS

1. Plot the locus of each of the following equations. Prove that the locus is a straight line in each case, and find the slope m and the point of intersection with the axis of y , $(0, b)$.

$$(a) \quad 2x + y - 6 = 0.$$

$$\text{Ans. } m = -2, b = 6.$$

$$(b) \quad x - 3y + 8 = 0.$$

$$\text{Ans. } m = \frac{1}{3}, b = 2\frac{2}{3}.$$

$$(c) \quad x + 2y = 0.$$

$$\text{Ans. } m = -\frac{1}{2}, b = 0.$$

$$(d) \quad 5x - 6y - 5 = 0.$$

$$\text{Ans. } m = \frac{5}{6}, b = -\frac{5}{6}.$$

$$(e) \quad \frac{1}{2}x - \frac{2}{3}y - \frac{1}{8} = 0.$$

$$\text{Ans. } m = \frac{3}{4}, b = -\frac{3}{16}.$$

$$(f) \quad \frac{x}{5} - \frac{y}{6} - 1 = 0.$$

$$\text{Ans. } m = \frac{6}{5}, b = -6.$$

$$(g) \quad 7x - 8y = 0.$$

$$\text{Ans. } m = \frac{7}{8}, b = 0.$$

$$(h) \quad \frac{3}{2}x - \frac{2}{3}y - \frac{7}{8} = 0.$$

$$\text{Ans. } m = \frac{9}{4}, b = -1\frac{5}{16}.$$

2. Plot the locus of each of the equations following, and prove that the locus is a circle, finding the center (α, β) and the radius r in each case.

(a) $x^2 + y^2 - 16 = 0.$

Ans. $(\alpha, \beta) = (0, 0); r = 4.$

(b) $x^2 + y^2 - 49 = 0.$

Ans. $(\alpha, \beta) = (0, 0); r = 7.$

(c) $x^2 + y^2 - 25 = 0.$

Ans. $(\alpha, \beta) = (0, 0); r = 5.$

(d) $x^2 + y^2 + 4x = 0.$

Ans. $(\alpha, \beta) = (-2, 0); r = 2.$

(e) $x^2 + y^2 - 8y = 0.$

Ans. $(\alpha, \beta) = (0, 4); r = 4.$

(f) $x^2 + y^2 + 4x - 8y = 0.$

Ans. $(\alpha, \beta) = (-2, 4); r = \sqrt{20}.$

(g) $x^2 + y^2 - 6x + 4y - 12 = 0.$

Ans. $(\alpha, \beta) = (3, -2); r = 5.$

(h) $x^2 + y^2 - 4x + 9y - \frac{3}{4} = 0.$

Ans. $(\alpha, \beta) = (2, -\frac{9}{2}); r = 5.$

(i) $3x^2 + 3y^2 - 6x - 8y = 0.$

Ans. $(\alpha, \beta) = (1, \frac{4}{3}); r = \frac{5}{3}.$

The following problems illustrate cases in which the locus problem is *completely solved* by analytic methods, since the loci may be easily drawn and their nature determined.

3. Find the equation of the locus of a point whose distances from the axes XX' and YY' are in a constant ratio equal to $\frac{2}{3}$.

Ans. The straight line $2x - 3y = 0.$

4. Find the equation of the locus of a point the sum of whose distances from the axes of coördinates is always equal to 10.

Ans. The straight line $x + y - 10 = 0.$

5. A point moves so that the difference of the squares of its distances from $(3, 0)$ and $(0, -2)$ is always equal to 8. Find the equation of the locus and plot.

Ans. The parallel straight lines $6x + 4y + 3 = 0, 6x + 4y - 13 = 0.$

6. A point moves so as to be always equidistant from the axes of coördinates. Find the equation of the locus and plot.

Ans. The perpendicular straight lines $x + y = 0, x - y = 0.$

7. A point moves so as to be always equidistant from the straight lines $x - 4 = 0$ and $y + 5 = 0$. Find the equation of the locus and plot.

Ans. The perpendicular straight lines $x - y - 9 = 0, x + y + 1 = 0.$

8. Find the equation of the locus of a point the sum of the squares of whose distances from $(3, 0)$ and $(-3, 0)$ always equals 68. Plot the locus.

Ans. The circle $x^2 + y^2 = 25.$

9. Find the equation of the locus of a point which moves so that its distances from $(8, 0)$ and $(2, 0)$ are always in a constant ratio equal to 2. Plot the locus.

Ans. The circle $x^2 + y^2 = 16.$

10. A point moves so that the ratio of its distances from $(2, 1)$ and $(-4, 2)$ is always equal to $\frac{1}{2}$. Find the equation of the locus and plot.

Ans. The circle $3x^2 + 3y^2 - 24x - 4y = 0.$

In the proofs of the following theorems the choice of the axes of coördinates is left to the student, since no mention is made of either coördinates or equations in the problem. In such cases always choose the axes in the most convenient manner possible.

11. A point moves so that the sum of its distances from two perpendicular lines is constant. Show that the locus is a straight line.

Hint. Choosing the axes of coördinates to coincide with the given lines, the equation is $x + y = \text{constant}$.

12. A point moves so that the difference of the squares of its distances from two fixed points is constant. Show that the locus is a straight line.

Hint. Draw XX' through the fixed points, and YY' through their middle point. Then the fixed points may be written $(a, 0)$, $(-a, 0)$, and if the "constant difference" be denoted by k , we find for the locus $4ax = k$ or $4ax = -k$.

13. A point moves so that the sum of the squares of its distances from two fixed points is constant. Prove that the locus is a circle.

Hint. Choose axes as in problem 12.

14. A point moves so that the ratio of its distances from two fixed points is constant. Determine the nature of the locus.

Ans. A circle if the constant ratio is not equal to unity and a straight line if it is.

The following problems illustrate the

Theorem. *If an equation can be put in the form of a product of variable factors equal to zero, the locus is found by setting each factor equal to zero and plotting the locus of each equation separately.*

15. Draw the locus of $4x^2 - 9y^2 = 0$.

Solution. Factoring,

$$(1) \quad (2x - 3y)(2x + 3y) = 0.$$

Then, by the theorem, the locus consists of the straight lines

$$(2) \quad 2x - 3y = 0,$$

$$(3) \quad 2x + 3y = 0.$$

Proof. 1. The coördinates of any point (x_1, y_1) which satisfy (1) will satisfy either (2) or (3).

For if (x_1, y_1) satisfies (1),

$$(4) \quad (2x_1 - 3y_1)(2x_1 + 3y_1) = 0.$$

This product can vanish only when one of the factors is zero. Hence either

$$2x_1 - 3y_1 = 0,$$

and therefore (x_1, y_1) satisfies (2);

or

$$2x_1 + 3y_1 = 0,$$

and therefore (x_1, y_1) satisfies (3).

2. A point (x_1, y_1) on either of the lines defined by (2) and (3) will also lie on the locus of (1).

For if (x_1, y_1) is on the line $2x - 3y = 0$, then (Corollary, p. 53)

$$(5) \quad 2x_1 - 3y_1 = 0.$$

Hence the product $(2x_1 - 3y_1)(2x_1 + 3y_1)$ also vanishes, since by (5) the first factor is zero, and therefore (x_1, y_1) satisfies (1).

Therefore every point on the locus of (1) is also on the locus of (2) and (3), and conversely. This proves the theorem for this example. Q.E.D.

16. Show that the locus of each of the following equations is a pair of straight lines, and plot the lines.

(a) $x^2 - y^2 = 0.$

(j) $3x^2 + xy - 2y^2 + 6x - 4y = 0.$

(b) $9x^2 - y^2 = 0.$

(k) $x^2 - y^2 + x + y = 0.$

(c) $x^2 = 9y^2.$

(l) $x^2 - xy + 5x - 5y = 0.$

(d) $x^2 - 4x - 5 = 0.$

(m) $x^2 - 2xy + y^2 + 6x - 6y = 0.$

(e) $y^2 - 6y = 7.$

(n) $x^2 - 4y^2 + 5x + 10y = 0.$

(f) $y^2 - 5xy + 6y = 0.$

(o) $x^2 + 4xy + 4y^2 + 5x + 10y + 6 = 0.$

(g) $xy - 2x^2 - 3x = 0.$

(p) $x^2 + 3xy + 2y^2 + x + y = 0.$

(h) $xy - 2x = 0.$

(q) $x^2 - 4xy - 5y^2 + 2x - 10y = 0.$

(i) $xy = 0.$

(r) $3x^2 - 2xy - y^2 + 5x - 5y = 0.$

17. Show that the locus of $Ax^2 + Bx + C = 0$ is a pair of parallel lines, a single line, or that there is no locus according as $\Delta = B^2 - 4AC$ is positive, zero, or negative.

18. Show that the locus of $Ax^2 + Bxy + Cy^2 = 0$ is a pair of intersecting lines, a single line, or a point according as $\Delta = B^2 - 4AC$ is positive, zero, or negative. *made by mag. ll*

33. Third fundamental problem. Discussion of an equation.

The method explained of solving the second fundamental problem gives no knowledge of the required curve except that it passes through all the points whose coördinates are determined as satisfying the given equation. Joining these points gives a curve more or less like the exact locus. Serious errors may be

made in this way, however, since *the nature of the curve between any two successive points plotted is not determined*. This objection is somewhat obviated by determining *before plotting* certain properties of the locus by a discussion of the given equation now to be explained.

The nature and properties of a locus depend upon the form of its equation, and hence the steps of any discussion must depend upon the particular problem. In every case, however, the following questions should be answered.

1. *Is the curve a closed curve or does it extend out infinitely far?*
2. *Is the curve symmetrical with respect to either axis or the origin?*

The method of deciding these questions is illustrated in the following examples.

Ex. 1. Plot the locus of

$$(1) \quad x^2 + 4y^2 = 16.$$

Discuss the equation.

Solution. First step. Solving for x ,

$$(2) \quad x = \pm 2\sqrt{4 - y^2}.$$

Second step. Assume values of y and compute x . This gives the table.

Third step. Plot the points of the table.

Fourth step. Draw a smooth curve through these points.

x	y	x	y
± 4	0	± 4	0
± 3.4	1	± 3.4	-1
± 2.7	$1\frac{1}{2}$	± 2.7	$-1\frac{1}{2}$
0	2	0	-2
imag.	3	imag.	-3

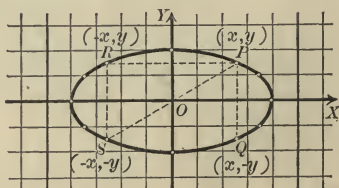

Discussion. 1. Equation (1) shows that neither x nor y can be indefinitely great, since x^2 and $4y^2$ are positive for all real values and their sum must equal 16. Therefore neither x^2 nor $4y^2$ can exceed 16. Hence *the curve is a closed curve*.

A second way of proving this is the following:

From (2), the ordinate y cannot exceed 2 nor be less than -2, since the expression $4 - y^2$ beneath the radical must not be negative. (2) also shows that x has values only from -4 to 4 inclusive.

2. To determine the symmetry with respect to the axes we proceed as follows:

The equation (1) contains no odd powers of x or y ; hence it may be written in any one of the forms

$$(3) \quad (x)^2 + 4(-y)^2 = 16, \text{ replacing } (x, y) \text{ by } (x, -y);$$

$$(4) \quad (-x)^2 + 4(y)^2 = 16, \text{ replacing } (x, y) \text{ by } (-x, y);$$

$$(5) \quad (-x)^2 + 4(-y)^2 = 16, \text{ replacing } (x, y) \text{ by } (-x, -y).$$

The transformation of (1) into (3) corresponds in the figure to replacing each point $P(x, y)$ on the curve by the point $Q(x, -y)$. But the points P and Q are symmetrical with respect to XX' , and (1) and (3) have the same locus (Theorem III, p. 59). Hence the locus of (1) is unchanged if each point is changed to a second point symmetrical to the first with respect to XX' . Therefore *the locus is symmetrical with respect to the axis of x* . Similarly from (4), *the locus is symmetrical with respect to the axis of y* , and from (5), *the locus is symmetrical with respect to the origin*.

The locus is called an ellipse.

Ex. 2. Plot the locus of

$$(6) \quad y^2 - 4x + 15 = 0.$$

Discuss the equation.

Solution. First step. Solve the equation for x , since a square root would have to be extracted if we solved for y . This gives

$$(7) \quad x = \frac{1}{4}(y^2 + 15).$$

x	y
$3\frac{3}{4}$	0
4	± 1
$4\frac{3}{4}$	± 2
6	± 3
$7\frac{3}{4}$	± 4
10	± 5
$12\frac{3}{4}$	± 6
etc.	etc.

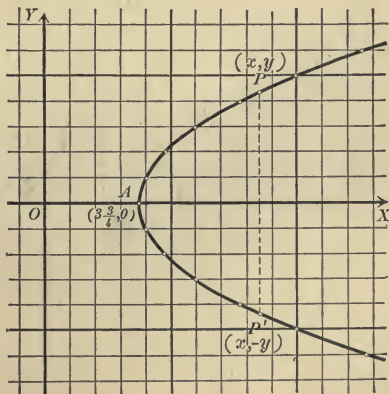

Second step. Assume values for y and compute x .

Since y^2 only appears in the equation, positive and negative values of y give the same value of x . The calculation gives the table on p. 69.

For example, if $y = \pm 3$,
then $x = \frac{1}{4}(9 + 15) = 6$, etc.

Third step. Plot the points of the table.

Fourth step. Draw a smooth curve through these points.

Discussion. 1. From (7) it is evident that x increases as y increases. Hence the curve extends out indefinitely far from both axes.

2. Since (6) contains no odd powers of y , the equation may be written in the form

$$(-y)^2 - 4(x) + 15 = 0$$

by replacing (x, y) by $(x, -y)$. Hence the locus is symmetrical with respect to the axis of x .

The curve is called a parabola.

Ex. 3. Plot the locus of the equation

$$(8) \quad xy - 2y - 4 = 0.$$

Solution. First step. Solving for y ,

$$(9) \quad y = \frac{4}{x-2}.$$

Second step. Compute y , assuming values for x .

x	y	x	y
0	-2	0	-2
1	-4	-1	$-\frac{4}{3}$
$1\frac{1}{2}$	-8	-2	-1
$1\frac{3}{4}$	-16	-4	$-\frac{2}{3}$
2	∞	-5	$-\frac{4}{7}$
$2\frac{1}{4}$	16	:	:
$2\frac{1}{2}$	8	-10	$-\frac{1}{3}$
3	4	etc.	etc.
4	2		
5	$\frac{4}{3}$		
6	1		
:			
12	0.4		
etc.	etc.		

When $x = 2$, $y = \frac{4}{0} = \infty$.

In such cases we assume values differing slightly from 2, both less and greater, as in the table.

Third step. Plot the points.

Fourth step. Draw the curve as in the figure in this case, the curve having two branches.

1. From (9) it appears that y diminishes and approaches zero as x increases indefinitely. The curve therefore extends indefinitely far to the right and left, approaching constantly the axis of x . If we solve (8) for x and write the result in the form

$$x = 2 + \frac{4}{y},$$

it is evident that x approaches 2 as y increases indefinitely. Hence the locus extends both upward and downward indefinitely far, approaching in each case the line $x = 2$.

2. The equation cannot be transformed by any one of the three substitutions

$$(x, y) \text{ into } (x, -y),$$

$$(x, y) \text{ into } (-x, y),$$

$$(x, y) \text{ into } (-x, -y),$$

without altering it in such a way that the new equation will not have the same locus. The locus is therefore not symmetrical with respect to either axis, nor with respect to the origin.

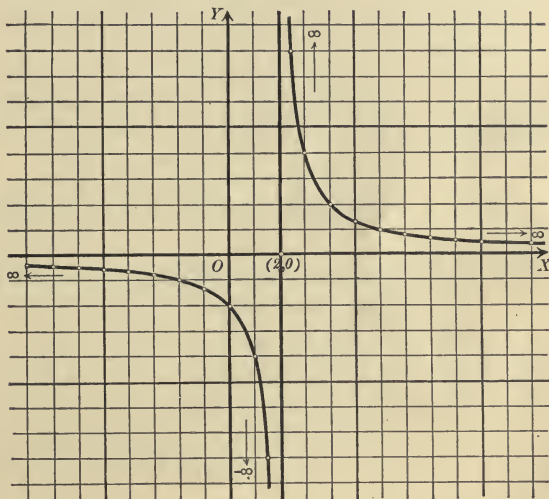

This curve is called an hyperbola.

Ex. 4. Draw the locus of the equation

(10) $4y = x^3.$

Solution. First step. Solving for y ,

$$y = \frac{1}{4}x^3.$$

Second step. Assume values for x and compute y . Values of x must be taken between the integers in order to give points not too far apart.

For example, if

$$x = 2\frac{1}{2},$$

$$y = \frac{1}{4} \cdot 12\frac{5}{8} = \frac{125}{32} = 3\frac{9}{32}, \text{ etc.}$$

x	y	x	y
0	0	0	0
1	$\frac{1}{4}$	-1	$-\frac{1}{4}$
$1\frac{1}{2}$	$\frac{27}{32}$	$-1\frac{1}{2}$	$-\frac{27}{32}$
2	2	-2	-2
$2\frac{1}{2}$	$3\frac{29}{32}$	$-2\frac{1}{2}$	$-3\frac{29}{32}$
3	$6\frac{3}{4}$	-3	$-6\frac{3}{4}$
$3\frac{1}{2}$	$10\frac{23}{32}$	$-3\frac{1}{2}$	$-10\frac{23}{32}$

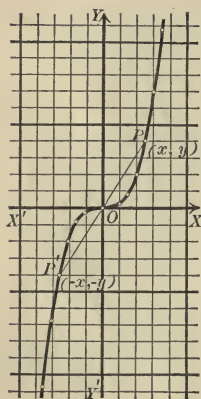

Third step. Plot the points thus found.

Fourth step. The points determine the curve of the figure.

Discussion. 1. From the given equation (10), x and y increase simultaneously, and therefore the curve extends out indefinitely from both axes.

2. In (10) there are no even powers nor constant term, so that by changing signs the equation may be written in the form

$$4(-y) = (-x)^3,$$

replacing (x, y) by $(-x, -y)$.

Hence the locus is symmetrical with respect to the origin.

The locus is called a cubical parabola.

34. Symmetry. In the above examples we have assumed the definition:

If the points of a curve can be arranged in pairs which are symmetrical with respect to an axis or a point, then the curve itself is said to be **symmetrical** with respect to that axis or point.

The method used for testing an equation for symmetry of the locus was as follows: if (x, y) can be replaced by $(x, -y)$ throughout the equation without affecting the locus, then if (a, b) is on the locus, $(a, -b)$ is also on the locus, and the points of the latter occur in pairs symmetrical with respect to XX' , etc. Hence

Theorem IV. *If the locus of an equation is unaffected by replacing y by $-y$ throughout its equation, the locus is symmetrical with respect to the axis of x .*

If the locus is unaffected by changing x to $-x$ throughout its equation, the locus is symmetrical with respect to the axis of y .

If the locus is unaffected by changing both x and y to $-x$ and $-y$ throughout its equation, the locus is symmetrical with respect to the origin.

These theorems may be made to assume a somewhat different form if the equation is *algebraic* in x and y (p. 17). The locus of an algebraic equation in the variables x and y is called an **algebraic curve**. Then from Theorem IV follows

3

Theorem V. *Symmetry of an algebraic curve. If no odd powers of y occur in an equation, the locus is symmetrical with respect to XX' ; if no odd powers of x occur, the locus is symmetrical with respect to YY' . If every term is of even* degree, or every term of odd degree, the locus is symmetrical with respect to the origin.*

35. Further discussion. In this section we treat of three more questions which enter into the discussion of an equation.

3. Is the origin on the curve?

This question is settled by

Theorem VI. *The locus of an algebraic equation passes through the origin when there is no constant term in the equation.*

Proof. The coördinates $(0, 0)$ satisfy the equation when there is no constant term. Hence the origin lies on the curve (Corollary, p. 53). Q. E. D.

4. What values of x and y are to be excluded?

Since coördinates are real numbers we have the

Rule to determine all values of x and y which must be excluded.

First step. Solve the equation for x in terms of y , and from this result determine all values of y for which the computed value of x will be imaginary. These values of y must be excluded.

Second step. Solve the equation for y in terms of x , and from this result determine all values of x for which the computed value of y will be imaginary. These values of x must be excluded.

The **intercepts** of a curve on the axis of x are the abscissas of the points of intersection of the curve and XX' .

The intercepts of a curve on the axis of y are the ordinates of the points of intersection of the curve and YY' .

Rule to find the intercepts.

Substitute $y = 0$ and solve for real values of x . This gives the intercepts on the axis of x .

Substitute $x = 0$ and solve for real values of y . This gives the intercepts on the axis of y .

* The constant term must be regarded as of even (zero) degree.

The proof of the rule follows at once from the definitions. The rule just given explains how to answer the question :

5. What are the intercepts of the locus ?

36. Directions for discussing an equation. Given an equation, the following questions should be answered in order before plotting the locus.

1. *Is the origin on the locus? (Theorem VI).*

2. *Is the locus symmetrical with respect to the axes or the origin? (Theorems IV and V).*

3. *What are the intercepts? (Rule, p. 73).*

4. *What values of x and y must be excluded? (Rule, p. 73).*

5. *Is the curve closed or does it pass off indefinitely far? (§ 33, p. 68).*

Answering these questions constitutes what is called a general discussion of the given equation.

Ex. 1. Give a general discussion of the equation

$$(1) \quad x^2 - 4y^2 + 16y = 0.$$

Draw the locus.

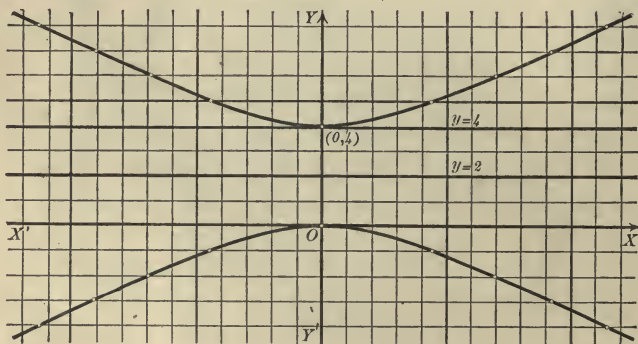

1. Since the equation contains no constant term, the origin is on the curve.
 2. The equation contains no odd powers of x ; hence the locus is symmetrical with respect to YY' .

3. Putting $y = 0$, we find $x = 0$, the intercept on the axis of x . Putting $x = 0$, we find $y = 0$ and 4 , the intercepts on the axis of y .

4. Solving for x ,

$$(2) \quad x = \pm 2\sqrt{y^2 - 4y}.$$

Hence all values of y between 0 and 4 must be excluded, since for such a value $y^2 - 4y$ is negative (Theorem III, p. 11).

Solving for y ,

$$(3) \quad y = 2 \pm \frac{1}{2} \sqrt{x^2 + 16}.$$

Hence no value of x is excluded, since $x^2 + 16$ is always positive.

5. From (3), y increases as x increases, and the curve extends out indefinitely far from both axes.

Plotting the locus, using (2), the curve is found to be as in the figure. The curve is an hyperbola.

PROBLEMS

1. Give a general discussion of each of the following equations and draw the locus.

(a) $x^2 - 4y = 0.$

(n) $9y^2 - x^3 = 0.$

(b) $y^2 - 4x + 3 = 0.$

(o) $9y^2 + x^3 = 0.$

(c) $x^2 + 4y^2 - 16 = 0.$

(p) $2xy + 3x - 4 = 0.$

(d) $9x^2 + y^2 - 18 = 0.$

(q) $x^2 - xy + 8 = 0.$

(e) $x^2 - 4y^2 - 16 = 0.$

(r) $x^2 + xy - 4 = 0.$

(f) $x^2 - 4y^2 + 16 = 0.$

(s) $x^2 + 2xy - 3y = 0.$

(g) $x^2 - y^2 + 4 = 0.$

(t) $2xy - y^3 + 4x = 0.$

(h) $x^2 - y + x = 0.$

(u) $3x^2 - y + x = 0.$

(i) $xy - 4 = 0.$

(v) $4y^2 - 2x - y = 0.$

(j) $9y + x^3 = 0.$

(w) $x^2 - y^2 + 6x = 0.$

(k) $4x - y^3 = 0.$

(x) $x^2 + 4y^2 + 8y = 0.$

(l) $6x - y^4 = 0.$

(y) $9x^2 + y^2 + 18x - 6y = 0.$

(m) $5x - y + y^3 = 0.$

(z) $9x^2 - y^2 + 18x + 6y = 0.$

2. Determine the general nature of the locus in each of the following equations by assuming *particular* values for the arbitrary constants, but not *special* values, that is, values which give the equation an added peculiarity.*

(a) $y^2 = 2mx.$

(f) $x^2 - y^2 = a^2.$

(b) $x^2 - 2my = m^2.$

(g) $x^2 + y^2 = r^2.$

(c) $\frac{x^2}{a^2} + \frac{y^2}{b^2} = 1.$

(h) $x^2 + y^2 = 2rx.$

(d) $2xy = a^2.$

(i) $x^2 + y^2 = 2ry.$

(e) $\frac{x^2}{a^2} - \frac{y^2}{b^2} = 1.$

(j) $x^2 + y^2 = 2ax + 2by.$

(k) $ay^2 = x^3.$

(l) $a^2y = x^3.$

* For example, in (a) and (b) $m=0$ is a special value. In fact, in all these examples zero is a special value for any constant.

3. Draw the locus of the equation

$$y^2 = (x - a)(x - b)(x - c),$$

(a) when $a < b < c$.

(c) when $a < b, b = c$.

(b) when $a = b < c$.

(d) when $a = b = c$.

The loci of the equations (a) to (f) in problem 2 are all of the class known as *conics*, or *conic sections*, — curves following straight lines and circles in the matter of their simplicity.

A **conic section** is the locus of a point whose distances from a fixed point and a fixed line are in a constant ratio.

4. Show that every conic is represented by an equation of the second degree in x and y .

Hint. Take YY' to coincide with the fixed line, and draw XX' through the fixed point. Denote the fixed point by $(p, 0)$ and the constant ratio by e .

$$Ans. (1 - e^2)x^2 + y^2 - 2px + p^2 = 0.$$

5. Discuss and plot the locus of the equation of problem 4,

(a) when $e = 1$. The conic is now called a *parabola* (see p. 70).

(b) when $e < 1$. The conic is now called an *ellipse* (see p. 69).

(c) when $e > 1$. The conic is now called an *hyperbola* (see p. 71).

6. Plot each of the following.

- | | | |
|---------------------------|-------------------------------------|----------------------------------|
| (a) $x^2y - 5 = 0$. | (e) $y = \frac{5}{x^2 - 3x}$. | (i) $x = \frac{y^2}{y - 1}$. |
| (b) $x^2y - y + 2x = 0$. | (f) $y = \frac{4x^2}{x^2 - 4}$. | (j) $x = \frac{y - 2}{y - 3}$. |
| (c) $xy^2 - 4x + 6 = 0$. | (g) $y = \frac{x - 3}{x + 1}$. | (k) $4x = \frac{y^2}{y^2 - 9}$. |
| (d) $x^3y - y + 8 = 0$. | (h) $y = \frac{x^2 - 4}{x^2 + x}$. | (l) $x = \frac{8y}{3 - y^2}$. |

37. Points of intersection. If two curves whose equations are given intersect, the coördinates of each point of intersection must satisfy both equations when substituted in them for the variables (Corollary, p. 53). In Algebra it is shown that *all* values satisfying two equations in two unknowns may be found by regarding these equations as simultaneous in the unknowns and solving. Hence the

Rule to find the points of intersection of two curves whose equations are given.

First step. Consider the equations as simultaneous in the coördinates, and solve as in Algebra.

Second step. Arrange the real solutions in corresponding pairs. These will be the coördinates of all the points of intersection.

Notice that only *real* solutions correspond to common points of the two curves, since coördinates are always real numbers.

Ex. 1. Find the points of intersection of

$$(1) \quad x - 7y + 25 = 0,$$

$$(2) \quad x^2 + y^2 = 25.$$

Solution. First step. Solving

(1) for x ,

$$(3) \quad x = 7y - 25.$$

Substituting in (2),

$$(7y - 25)^2 + y^2 = 25.$$

Reducing, $y^2 - 7y + 12 = 0$.

$$\therefore y = 3 \text{ and } 4.$$

Substituting in (3) [not in (2)],

$$x = -4 \text{ and } +3.$$

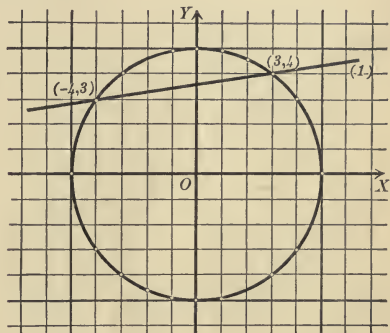

Second step. Arranging, the points of intersection are $(-4, 3)$ and $(3, 4)$. *Ans.*

In the figure the straight line (1) is the locus of equation (1), and the circle the locus of (2).

Ex. 2. Find the points of intersection of the loci of

$$(4) \quad 2x^2 + 3y^2 = 35,$$

$$(5) \quad 3x^2 - 4y = 0.$$

Solution. First step. Solving (5) for x^2 ,

$$(6) \quad x^2 = \frac{4}{3}y.$$

Substituting in (4) and reducing,

$$9y^2 + 8y - 105 = 0.$$

$$\therefore y = 3 \text{ and } -\frac{35}{9}.$$

Substituting in (6) and solving,

$$x = \pm 2 \text{ and } \pm \frac{2}{3}\sqrt{-105}.$$

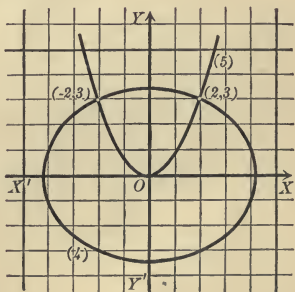

Second step. Arranging the *real* values, we find the points of intersection are $(+2, 3)$, $(-2, 3)$. *Ans.*

In the figure the ellipse (4) is the locus of (4), and the parabola (5) the locus of (5).

PROBLEMS

Find the points of intersection of the following loci.

1. $\left. \begin{array}{l} 7x - 11y + 1 = 0 \\ x + y - 2 = 0 \end{array} \right\}$. *Ans.* $(\frac{7}{6}, \frac{5}{6})$.
2. $\left. \begin{array}{l} x + y = 7 \\ x - y = 5 \end{array} \right\}$. *Ans.* (6, 1).
3. $\left. \begin{array}{l} y = 3x + 2 \\ x^2 + y^2 = 4 \end{array} \right\}$. *Ans.* (0, 2), $(-\frac{6}{5}, -\frac{8}{5})$.
4. $\left. \begin{array}{l} y^2 = 16x \\ y - x = 0 \end{array} \right\}$. *Ans.* (0, 0), (16, 16).
5. $\left. \begin{array}{l} x^2 + y^2 = a^2 \\ 3x + y + a = 0 \end{array} \right\}$. *Ans.* (0, -a), $(-\frac{3a}{5}, \frac{4a}{5})$.
6. $\left. \begin{array}{l} x^2 + y^2 - 4x + 6y - 12 = 0 \\ 2y = 3x + 3 \end{array} \right\}$. *Ans.* $(\frac{1}{3}, \frac{2}{3})$, (-3, -3).
7. $\left. \begin{array}{l} x^2 - y^2 = 16 \\ x^2 = 8y \end{array} \right\}$. *Ans.* $(\pm 4\sqrt{2}, 4)$.
8. $\left. \begin{array}{l} x^2 + y^2 = 41 \\ xy = 20 \end{array} \right\}$. *Ans.* $(\pm 5, \pm 4)$, $(\pm 4, \pm 5)$.
9. $\left. \begin{array}{l} x^2 + y^2 - 6x - 2y - 15 = 0 \\ 9x^2 + 9y^2 + 6x - 6y - 27 = 0 \end{array} \right\}$. *Ans.* (-2, 1), $(-\frac{2}{3}, -\frac{1}{3})$.
10. $\left. \begin{array}{l} x^2 + y^2 = 49 \\ y = 3x + b \end{array} \right\}$. For what values of b are the curves tangent?
Ans. $(\frac{-3b \pm \sqrt{490 - b^2}}{10}, \frac{b \pm 3\sqrt{490 - b^2}}{10})$, $b = \pm 7\sqrt{10}$.
11. $\left. \begin{array}{l} y^2 = 2px \\ x^2 = 2py \end{array} \right\}$. *Ans.* (0, 0), (2p, 2p).
12. $\left. \begin{array}{l} 4x^2 + y^2 = 5 \\ y^2 = 8x \end{array} \right\}$. *Ans.* $(\frac{1}{2}, 2)$, $(\frac{1}{2}, -2)$.
13. $\left. \begin{array}{l} x^2 = 4ay \\ y = \frac{8a^3}{x^2 + 4a^2} \end{array} \right\}$. *Ans.* (2a, a), (-2a, a).
14. $\left. \begin{array}{l} x^2 + y^2 = 100 \\ y^2 = \frac{9x}{2} \end{array} \right\}$. *Ans.* (8, 6), (8, -6).
15. $\left. \begin{array}{l} x^2 + y^2 = 5a^2 \\ x^2 = 4ay \end{array} \right\}$. *Ans.* (2a, a), (-2a, a).
16. $\left. \begin{array}{l} b^2x^2 + a^2y^2 = a^2b^2 \\ x^2 + y^2 = a^2 \end{array} \right\}$. *Ans.* (a, 0), (-a, 0).

17. The two loci $\frac{x^2}{4} - \frac{y^2}{9} = 1$ and $\frac{x^2}{4} + \frac{y^2}{9} = 4$ intersect in four points. Find the lengths of the sides and of the diagonals of the quadrilateral formed by these points.

Ans. Points, $(\pm \sqrt{10}, \pm \frac{3}{2} \sqrt{6})$. Sides, $2\sqrt{10}, 3\sqrt{6}$. Diagonals, $\sqrt{94}$.

Find the area of the triangles and polygons whose sides are the loci of the following equations.

18. $3x + y + 4 = 0, 3x - 5y + 34 = 0, 3x - 2y + 1 = 0$. Ans. 36.

19. $x + 2y = 5, 2x + y = 7, y = x + 1$. Ans. $\frac{3}{2}$.

20. $x + y = a, x - 2y = 4a, y - x + 7a = 0$. Ans. $12a^2$.

21. $x = 0, y = 0, x = 4, y = -6$. Ans. 24.

22. $x - y = 0, x + y = 0, x - y = a, x + y = b$. Ans. $\frac{ab}{2}$.

23. $y = 3x - 9, y = 3x + 5, 2y = x - 6, 2y = x + 14$. Ans. 56.

24. Find the distance between the points of intersection of the curves $3x - 2y + 6 = 0, x^2 + y^2 = 9$. Ans. $\frac{1}{3}\sqrt{13}$.

25. Does the locus of $y^2 = 4x$ intersect the locus of $2x + 3y + 2 = 0$?
Ans. Yes.

26. For what value of a will the three lines $3x + y - 2 = 0, ax + 2y - 3 = 0, 2x - y - 3 = 0$ meet in a point? Ans. $a = 5$.

27. Find the length of the common chord of $x^2 + y^2 = 13$ and $y^2 = 3x + 3$.
Ans. 6.

28. If the equations of the sides of a triangle are $x + 7y + 11 = 0, 3x + y - 7 = 0, x - 3y + 1 = 0$, find the length of each of the medians.
Ans. $2\sqrt{5}, \frac{5}{2}\sqrt{2}, \frac{1}{2}\sqrt{170}$.

Show that the following loci intersect in two coincident points, that is, are tangent to each other.

29. $y^2 - 10x - 6y - 31 = 0, 2y - 10x = 47$.

30. $9x^2 - 4y^2 + 54x - 16y + 29 = 0, 15x - 8y + 11 = 0$.

38. **Transcendental curves.** The equations thus far considered have been *algebraic* in x and y , since powers alone of the variables have appeared. We shall now see how to plot certain so-called *transcendental curves*, in which the variables appear otherwise than in powers. The Rule, p. 60, will be followed.

Ex. 1. Draw the locus of

(1) $y = \log_{10} x.$

Solution. Assuming values for x , y may be computed by a table of logarithms, or, remembering the definition of a logarithm, from (1) will follow

(2) $x = 10^y.$

Hence values may also be assumed for y , and x computed by (2). This is done in the table.

x	y	x	y
1	0	.1	-1
3.1	$\frac{1}{2}$.01	-2
10	1	.001	-3
100	2	.0001	-4
etc.	etc.	etc.	etc.

In plotting,

unit length on XX' is 2 divisions,

unit length on YY' is 4 divisions.

General discussion. 1. The curve does not pass through the origin, since $(0, 0)$ does not satisfy the equation.

2. The curve is not symmetrical with respect to either axis or the origin.

3. In (1), putting $x = 0$,

$$y = \log 0 = -\infty = \text{intercept on } YY'.$$

In (2), putting $y = 0$,

$$x = 10^0 = 1 = \text{intercept on } XX'.$$

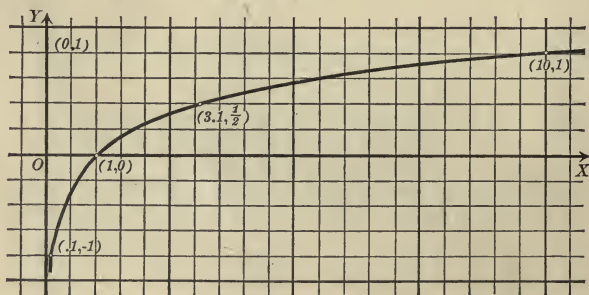

4. From (2), since logarithms of negative numbers do not exist, *all negative values of x are excluded.*

From (2) no value of y is excluded.

5. From (2), as y increases x increases, and the locus extends out indefinitely from both axes.

From (1), as

x approaches zero,

y approaches negative infinity;

so we see that the curve extends down indefinitely and approaches nearer and nearer to YY' .

Ex. 2. Draw the locus of

(3) $y = \sin x$

if the abscissa x is the *circular measure* of an angle (Chapter I, p. 19).

Solution. Assuming values for x and finding the corresponding number of degrees, we may compute y by the table of Natural Sines, p. 21.

For example, if

$$x = 1, \text{ since } 1 \text{ radian} = 57^\circ.29,$$

$$y = \sin 57^\circ.29 = .843.$$

[by (3)]

It will be more convenient for plotting to choose for x such values that the corresponding number of degrees is a whole number. Hence x is expressed in terms of π in the table.

For example, if

$$x = \frac{\pi}{3}, \quad y = \sin \frac{\pi}{3} = \sin 60^\circ = .86.$$

$$x = -\frac{2\pi}{3}, \quad y = \sin -\frac{2\pi}{3} = -\sin \frac{2\pi}{3} \quad (4, \text{ p. } 19)$$

$$= -\sin 120^\circ = -\sin 60^\circ \quad (5, \text{ p. } 20)$$

$$= -.86.$$

In plotting, three divisions being taken as the unit of length, lay off

$$AO = OB = \pi = 3.1416,$$

and divide AO and OB up into *six* equal parts.

The course of the curve beyond B is easily determined from the relation

$$\sin(2\pi + x) = \sin x.$$

$$\text{Hence } y = \sin x = \sin(2\pi + x),$$

that is, the curve is *unchanged* if $x + 2\pi$ be substituted for x . This means, however, that every point is moved a distance 2π to the right. Hence the arc

x	y	x	y
0	0	0	0
$\frac{\pi}{6}$.50	$-\frac{\pi}{6}$	-.50
$\frac{\pi}{3}$.86	$-\frac{\pi}{3}$	-.86
$\frac{\pi}{2}$	1.00	$-\frac{\pi}{2}$	-1.00
$\frac{2\pi}{3}$.86	$-\frac{2\pi}{3}$	-.86
$\frac{5\pi}{6}$.50	$-\frac{5\pi}{6}$	-.50
π	0	$-\pi$	0

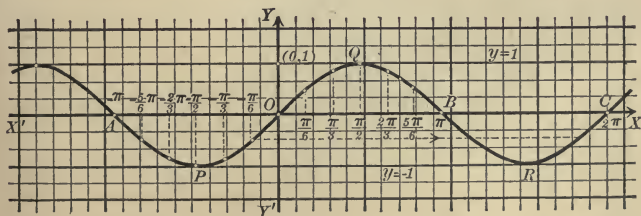

APO may be moved parallel to XX' until A falls on B , that is, into the position BRC , and it will also be a part of the curve in its new position.

Also, the arc OQB may be displaced parallel to XX' until O falls upon C . In this way it is seen that the entire locus consists of an indefinite number of congruent arcs, alternately above and below XX' .

General discussion. 1. The curve passes through the origin, since $(0, 0)$ satisfies the equation.

2. Since $\sin(-x) = -\sin x$, changing signs in (3),

$$-y = -\sin x,$$

or

$$-y = \sin(-x).$$

Hence the locus is unchanged if (x, y) is replaced by $(-x, -y)$, and the curve is *symmetrical with respect to the origin* (Theorem IV, p. 72).

3. In (3), if

$$x = 0,$$

$$y = \sin 0 = 0 = \text{intercept on the axis of } y.$$

Solving (3) for x ,

(4)

$$x = \sin^{-1} y.$$

In (4), if

$$y = 0,$$

$$x = \sin^{-1} 0$$

$$= n\pi, n \text{ being any integer.}$$

Hence the curve cuts the axis of x an indefinite number of times both on the right and left of O , these points being at a distance of π from one another.

4. In (3), x may have any value, since any number is the circular measure of an angle.

In (4), y may have values from -1 to $+1$ inclusive, since the sine of an angle has values only from -1 to $+1$ inclusive.

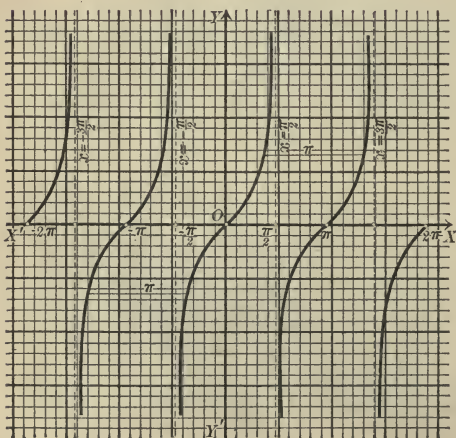

5. The curve extends out indefinitely along XX' in both directions, but is contained entirely between the lines $y = +1$, $y = -1$.

The locus is called the *wave curve*, from its shape, or the *sinusoid*, from its equation (3).

Ex. 3. Draw the locus of $y = \tan x$.

There is no difficulty in obtaining the curve of the figure and in verifying the properties indicated by a discussion similar to the preceding examples.

PROBLEMS

Plot the loci of the following equations.

1. $y = \cos x.$

5. $y = \tan^{-1} x.$

9. $y = \sin 2x.$

2. $y = \cot x.$

6. $y = 2^x.$

10. $y = \tan \frac{x}{2}.$

3. $y = \sec x.$

7. $y = 2 \log_{10} x.$

11. $y = 2 \cos x.$

4. $y = \sin^{-1} x.$

8. $y = (1+x)^{\frac{1}{x}}.$

12. $y = \sin x + \cos x.$

39. Graphical representation in general. Any equation containing two variables may be represented graphically by a curve called the *graph of the equation* by considering the variables as coördinates and plotting the locus in the usual way. This method of representing a given law is widely used in all branches of science.

Ex. 1. Draw the graph of the *Simple Interest Law*, which shall represent the relation between amount and time for a given principal and rate per cent. The law is proven in Algebra to be

$$(1) \quad A = P(1 + rn),$$

where A = amount, P = principal, r = rate, n = number of years.

Solution. For convenience, take $P =$ one dollar.* Let

One division on $OX = 1$ year,

One division on $OY = 1$ dollar,

abscissas = values of n ,

ordinates = values of A .

Then the required graph is the locus of

$$(2) \quad y = rx + 1.$$

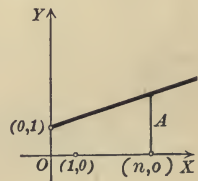

The locus of (2) is a straight line passing through $(0, 1)$ and having a slope equal to r (Theorem I, p. 58).

This graph may be used to solve interest problems. For if the number of years n is given, we merely have to measure off the corresponding ordinate A of the straight line, and this will give the amount of one dollar at the given rate for n years.

* Any other case is obtained by multiplying all the ordinates in the figure by P .

Ex. 2. In Physics it is shown that the volume (v), pressure (p), and absolute temperature (t) of a given mass of a perfect gas are connected by the law

$$(3) \quad pv = kt,$$

k being a constant dependent upon the particular gas.

Draw the graph if the temperature is assumed constant.

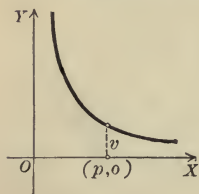

Solution. Assume

one division on OX = unit of pressure,
 one division on OY = unit of volume,
 abscissas = pressures,
 ordinates = volumes.

Then the required graph is the locus of

$$(4) \quad xy = \text{constant.}$$

The curve is one branch* of an hyperbola extending to the right and upward indefinitely, approaching in each case the corresponding axis. Such curves are called isothermals (equal temperatures), and the figure is called the Pressure-Volume Diagram.

PROBLEMS

1. Draw the graph of the Simple Interest Law if the variables are

(a) n and P .

(c) A and P .

(e) P and r .

(b) n and r .

(d) A and r .

2. Draw the graph of the law of Ex. 2 if the variables are

(a) p and t .

(b) v and t .

3. The amount (A) of any principal (P) at compound interest ($r\%$) for n years is given by the *Compound Interest Law*

$$A = P(1 + r)^n.$$

Draw the graph of this law if the variables are

(a) A and P .

(c) A and n .

(e) P and n .

(b) A and r .

(d) P and r .

(f) r and n .

Hint. Take the logarithm of both sides when convenient for computation.

* Since negative volumes have no physical meaning, in many cases only a portion of the entire locus can be made use of in the representation.

CHAPTER IV

THE STRAIGHT LINE AND THE GENERAL EQUATION OF THE FIRST DEGREE

40. The idea of coördinates and the intimate relation connecting a curve and an equation, which results from the introduction of coördinates into the study of Geometry, have been considered in the preceding chapters. Analytic Geometry has to do largely with a more detailed study of particular curves and equations. In this chapter we shall consider in detail the straight line and the general equation of the first degree in the variables x and y representing coördinates.

41. The degree of the equation of a straight line. It was shown in Chapter III (Theorem I, p. 58) that

$$(1) \quad y = mx + b$$

is the equation of the straight line whose slope is m and whose intercept on the Y -axis is b ; m and b may have any values, positive, negative, or zero (p. 34). But if a line is parallel to the Y -axis, its equation may not be put in the form (1); for, in the first place, the line has no intercept on the Y -axis, and, in the second place, its slope is infinite and hence cannot be substituted for m in (1). The equation of a line parallel to the Y -axis is, however, of the form

$$(2) \quad x = \text{constant.}$$

The equation of any line may be put either in the form (1) or (2). As these equations are both of the first degree in x and y we have

Theorem I. *The equation of any straight line is of the first degree in the coördinates x and y .*

42. The general equation of the first degree, $Ax + By + C = 0$.
The equation

$$(1) \quad Ax + By + C = 0,$$

where A , B , and C are arbitrary constants (p. 1), is called the general equation of the first degree in x and y because every equation of the first degree may be reduced to that form.

Equation (1) represents all straight lines.

For the equation $y = mx + b$ may be written $mx - y + b = 0$, which is of the form (1) if $A = m$, $B = -1$, $C = b$; and the equation $x = \text{constant}$ may be written $x - \text{constant} = 0$, which is of the form (1) if $A = 1$, $B = 0$, $C = -\text{constant}$.

Theorem II. (Converse of Theorem I.) *The locus of the general equation of the first degree*

$$Ax + By + C = 0$$

is a straight line.

Proof. Solving (1) for y , we obtain

$$(2) \quad y = -\frac{A}{B}x - \frac{C}{B}.$$

This equation has the same locus as (1) (Theorem III, p. 59).

By Theorem I, p. 58, the locus of (2) is the straight line whose slope is $m = -\frac{A}{B}$ and whose intercept on the Y -axis is $b = -\frac{C}{B}$.

If, however, $B = 0$, it is impossible to write (1) in the form (2). But if $B = 0$, (1) becomes

$$Ax + C = 0,$$

or
$$x = -\frac{C}{A}.$$

The locus of this equation is a straight line parallel to the Y -axis (1, p. 57). Hence in all cases the locus of (1) is a straight line.

Q. E. D.

Corollary I. *The slope of the line*

$$Ax + By + C = 0$$

is $m = -\frac{A}{B}$; that is, the coefficient of x with its sign changed divided by the coefficient of y .

Corollary II. *The lines*

$$Ax + By + C = 0$$

and

$$A'x + B'y + C' = 0$$

are parallel when and only when the coefficients of x and y are proportional; that is,

$$\frac{A}{A'} = \frac{B}{B'}.$$

For two lines are parallel when and only when their slopes are equal (Theorem VI, p. 36); that is, when and only when

$$-\frac{A}{B} = -\frac{A'}{B'}.$$

Changing the signs and applying alternation, we obtain

$$\frac{A}{A'} = \frac{B}{B'}.$$

Corollary III. *The lines*

$$Ax + By + C = 0$$

and

$$A'x + B'y + C' = 0$$

are perpendicular when and only when

$$AA' + BB' = 0.$$

For two lines are perpendicular when and only when the slope of one is the negative reciprocal of the slope of the second (Theorem VI, p. 36); that is,

$$-\frac{A}{B} = \frac{B'}{A'},$$

or

$$AA' + BB' = 0.$$

Corollary IV. *The intercepts of the line*

$$Ax + By + C = 0$$

on the X - and Y -axes are respectively

$$a = -\frac{C}{A} \text{ and } b = -\frac{C}{B}.$$

For the intercept on the X -axis is found (p. 73) by setting $y = 0$ and solving for x , and the intercept on the Y -axis has been found in the above proof.

Corollaries I and IV are given chiefly for purposes of reference. In a numerical example the intercepts are found most simply by applying the general rule already given (p. 73); and the slope is found by reducing the equation to the form

$$y = mx + b,$$

when the coefficient of x will be the slope.

Theorems I and II may be stated together as follows :

The locus of an equation is a straight line when and only when the equation is of the first degree in x and y .

Theorem II asserts that the locus of every equation of the first degree is a straight line. Then, to plot the locus of an equation of the first degree it is merely necessary to plot two points on the locus and draw the straight line passing through them. The two simplest points to plot are those at which the line crosses the axes. But if those points are very near the origin it is better to use but one of them and some other point not near the origin whose coördinates are found by the Rule on p. 60.

Theorem III. *When two equations of the first degree,*

$$(3) \quad Ax + By + C = 0$$

and

$$(4) \quad A'x + B'y + C' = 0,$$

have the same locus, then the corresponding coefficients are proportional; that is,

$$\frac{A}{A'} = \frac{B}{B'} = \frac{C}{C'}.$$

Proof. The lines whose equations are (3) and (4) are by hypothesis identical and hence they have the same slope and the same intercept on the Y -axis. Since they have the same slope,

$$\frac{A}{B} = \frac{A'}{B'}, \quad (\text{Corollary I, p. 86})$$

and since they have the same intercept on the Y -axis,

$$\frac{C}{B} = \frac{C'}{B'}, \quad (\text{Corollary IV, p. 87})$$

by alternation we obtain

$$\frac{A}{A'} = \frac{B}{B'} \quad \text{and} \quad \frac{C}{C'} = \frac{B}{B'};$$

and hence

$$\frac{A}{A'} = \frac{B}{B'} = \frac{C}{C'}.$$

Ex. 1. Find the values of a and b for which the equations

$$2ax + 2y - 5 = 0$$

and

$$4x - 3y + 7b = 0$$

will represent the same straight line.

Solution. These two equations will represent the same straight line if (Theorem III)

$$\frac{2a}{4} = \frac{2}{-3} = \frac{-5}{7b};$$

and hence the required values are obtained by solving

$$\frac{2a}{4} = \frac{2}{-3} \quad \text{and} \quad \frac{2}{-3} = \frac{-5}{7b}$$

for a and b . This gives

$$a = -\frac{4}{3}, \quad b = \frac{15}{14}.$$

43. Geometric interpretation of the solution of two equations of the first degree. If we solve the equations

$$(1) \quad Ax + By + C = 0$$

and

$$(2) \quad A'x + B'y + C' = 0,$$

we obtain the coördinates of the points of intersection of the lines whose equations are (1) and (2) (Rule, p. 76). But if these lines are parallel they do not intersect, and if they are identical they intersect in all of their points. The relation between the *position* of the lines whose equations are (1) and (2) and the *number of solutions* of the simultaneous equations (1) and (2) may be indicated as follows:

<i>Position of lines</i>	<i>Number of solutions of equations</i>
Intersecting lines.	One solution.
Parallel lines.	No solution.
Coincident lines.	An infinite number.

It is sometimes as convenient to be able to determine the *number* of solutions of two equations of the first degree without solving them as it is to be able to determine the *nature* of the roots of a quadratic equation without solving it. The following theorem enables us to do this.

Theorem IV. *Two equations of the first degree,*

$$Ax + By + C = 0$$

and

$$A'x + B'y + C' = 0,$$

have, in general, one solution for x and y ; but if

$$\frac{A}{A'} = \frac{B}{B'},$$

there is no solution unless

$$\frac{A}{A'} = \frac{B}{B'} = \frac{C}{C'},$$

when there is an infinite number of solutions.

The proof follows at once from Corollary II, p. 87, and Theorem III.

PROBLEMS

1. Find the intercepts of the following lines and plot the lines.

(a) $2x + 3y = 6.$

Ans. 3, 2.

(b) $\frac{x}{2} + \frac{y}{4} = 1.$

Ans. 2, 4.

(c) $\frac{x}{3} - \frac{y}{5} = 1.$

Ans. 3, -5.

(d) $\frac{x}{4} + \frac{y}{-2} = 1.$

Ans. 4, -2.

2. Plot the following lines.

(a) $2x - 3y + 5 = 0.$

(c) $\frac{x}{2} + \frac{y}{3} = 1.$

(b) $y - 5 - 4x = 0.$

(d) $\frac{x}{3} - \frac{y}{4} = 1.$

3. Find the equations, and reduce them to the general form, of the lines for which

(a) $m = 2, b = -3.$

Ans. $2x - y - 3 = 0.$

(b) $m = -\frac{1}{2}, b = \frac{3}{2}.$

Ans. $x + 2y - 3 = 0.$

(c) $m = \frac{2}{5}, b = -\frac{5}{2}.$

Ans. $4x - 10y - 25 = 0.$

(d) $\alpha = \frac{\pi}{4}, b = -2.$

Ans. $x - y - 2 = 0.$

(e) $\alpha = \frac{3\pi}{4}, b = 3.$

Ans. $x + y - 3 = 0.$

Hint. Substitute in $y = mx + b.$

4. Find the number of solutions of the following pairs of equations and plot the loci of the equations.

$$(a) \begin{cases} 2x + 3y - 6 = 0. \\ 4x + 6y + 9 = 0. \end{cases} \quad \text{Ans. No solution.}$$

$$(b) \begin{cases} x - y = 1. \\ x + y = 1. \end{cases} \quad \text{Ans. One.}$$

$$(c) \begin{cases} 2 - 3x = y. \\ 6x + 2y = 4. \end{cases} \quad \text{Ans. An infinite number.}$$

$$(d) \begin{cases} 4x - 5y + 20 = 0. \\ 12x - 15y + 6 = 0. \end{cases} \quad \text{Ans. No solution.}$$

5. Plot the lines $2x - 3y + 6 = 0$ and $x - y = 0$. Also plot the locus of $(2x - 3y + 6) + k(x - y) = 0$ for $k = 0, \pm 1, \pm 2$.

6. Select pairs of parallel and perpendicular lines from the following.

$$(a) \begin{cases} L_1: y = 2x - 3. \\ L_2: y = -3x + 2. \\ L_3: y = 2x + 7. \\ L_4: y = \frac{1}{3}x + 4. \end{cases} \quad \text{Ans. } L_1 \parallel L_3; L_2 \perp L_4.$$

$$(b) \begin{cases} L_1: x + 3y = 0. \\ L_2: 8x + y + 1 = 0. \\ L_3: 9x - 3y + 2 = 0. \end{cases} \quad \text{Ans. } L_1 \perp L_3.$$

$$(c) \begin{cases} L_1: 2x - 5y = 8. \\ L_2: 5y + 2x = 8. \\ L_3: 35x - 14y = 8. \end{cases} \quad \text{Ans. } L_2 \perp L_3.$$

7. Show that the quadrilateral whose sides are $2x - 3y + 4 = 0$, $3x - y - 2 = 0$, $4x - 6y - 9 = 0$, and $6x - 2y + 4 = 0$ is a parallelogram.

8. Find the equation of the line whose slope is -2 which passes through the point of intersection of $y = 3x + 4$ and $y = -x + 4$.

$$\text{Ans. } 2x + y - 4 = 0.$$

9. What is the locus of $y = mx + b$ if b is constant and m arbitrary? if m is constant and b arbitrary?

10. Write an equation which will represent all lines parallel to the line

$$(a) y = 2x + 7.$$

$$(c) y - 3x - 4 = 0.$$

$$(b) y = -x + 9.$$

$$(d) 2y - 4x + 3 = 0.$$

11. Write an equation which will represent all lines having the same intercept on the Y-axis as (a), (b), (c), and (d) in problem 10.

12. Find the equation of the line parallel to $2x - 3y = 0$ whose intercept on the Y-axis is -2 .

$$\text{Ans. } 2x - 3y - 6 = 0.$$

13. What is the locus of $Ax + By + C = 0$ if B and C are constant and A arbitrary? if A and B are constant and C arbitrary?

44. Straight lines determined by two conditions. In Elementary Geometry we have many illustrations of the determination of a straight line by two conditions. Thus two points determine a line, and through a given point one line, and only one, can be drawn parallel to a given line. Sometimes, however, there will be two or more lines satisfying the two conditions; thus through a given point outside of a circle we can draw two lines tangent to the circle, and four lines may be drawn tangent to two circles if they do not intersect.

Analytically such facts present themselves as follows. The equation of any straight line is of the form (Theorem II, p. 86)

$$(1) \quad Ax + By + C = 0,$$

and the line is completely determined if the values of two of the coefficients A , B , and C are known in terms of the third.

For example, if $A = 2B$ and $C = -3B$, equation (1) becomes

$$\begin{aligned} & 2Bx + By - 3B = 0, \\ \text{or} \quad & 2x + y - 3 = 0. \end{aligned}$$

Any geometrical condition which the line must satisfy gives rise to an equation between one or more of the coefficients A , B , and C .

Thus if the line is to pass through the origin, we must have $C = 0$ (Theorem VI, p. 73); or if the slope is to be 3, then $-\frac{A}{B} = 3$ (Corollary I, p. 86).

Two conditions which the line must satisfy will then give rise to two equations in A , B , and C from which the values of two of the coefficients may be determined in terms of the third, and the line is then determined.

If these equations are of the first degree, there will be only one line fulfilling the given conditions, for two equations of the first degree have, in general, only one solution (Theorem IV, p. 90). If one equation is a quadratic and the other of the first degree, then there will be two lines fulfilling the conditions, provided that the solutions of the equations are real. And, in general, the number of lines fulfilling the two given conditions will depend on the degrees of the equations in the A , B , and C to which they give rise.

Rule to determine the equation of a straight line which satisfies two conditions.

First step. Assume that the equation of the line is

$$Ax + By + C = 0.$$

Second step. Find two equations between A , B , and C each of which expresses algebraically the fact that the line satisfies one of the given conditions.

Third step. Solve these equations for two of the coefficients A , B , and C in terms of the third.

Fourth step. Substitute the results of the third step in the equation in the first step and divide out the remaining coefficient. The result is the required equation.

Ex. 1. Find the equation of the line through the two points $P_1(5, -1)$ and $P_2(2, -2)$.

Solution. First step. Let the required equation be

$$(1) \quad Ax + By + C = 0.$$

Second step. Since P_1 lies on the locus of (1) (Corollary, p. 53),

$$(2) \quad 5A - B + C = 0;$$

and since P_2 lies on the line,

$$(3) \quad 2A - 2B + C = 0.$$

Third step. Solving (2) and (3) for A and B in terms of C , we obtain

$$A = -\frac{1}{3}C, \quad B = \frac{2}{3}C.$$

Fourth step. Substituting in (1),

$$-\frac{1}{3}Cx + \frac{2}{3}Cy + C = 0.$$

Dividing by C and simplifying, the required equation is

$$x - 3y - 8 = 0.$$

Ex. 2. Find the equation of the line passing through $P_1(3, -2)$ whose slope is $-\frac{1}{4}$.

Solution. First step. Let the required equation be

$$(4) \quad Ax + By + C = 0.$$

Second step. Since P_1 lies on (4),

$$(5) \quad 3A - 2B + C = 0;$$

and since the slope is $-\frac{1}{4}$,

$$(6) \quad -\frac{A}{B} = -\frac{1}{4}.$$

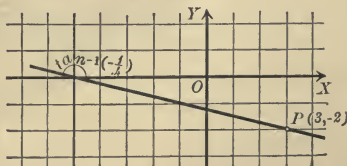
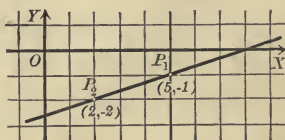

Third step. Solving (5) and (6) for A and C in terms of B , we obtain

$$A = \frac{1}{4}B, \quad C = \frac{5}{4}B.$$

Fourth step. Substituting in (4),

$$\frac{1}{4}Bx + By + \frac{5}{4}B = 0,$$

or

$$x + 4y + 5 = 0.$$

PROBLEMS

1. Find the equation of the line satisfying the following conditions and plot the lines.

- | | |
|--------------------------------------------------|-----------------------------------------------|
| (a) Passing through (0, 0) and (8, 2). | <i>Ans.</i> $x - 4y = 0$. |
| (b) Passing through (-1, 1) and (-3, 1). | <i>Ans.</i> $y - 1 = 0$. |
| (c) Passing through (-3, 1) and slope = 2. | <i>Ans.</i> $2x - y + 7 = 0$. |
| (d) Having the intercepts $a = 3$ and $b = -2$. | <i>Ans.</i> $2x - 3y - 6 = 0$. |
| (e) Slope = -3, intercept on X -axis = 4. | <i>Ans.</i> $3x + y - 12 = 0$. |
| (f) Intercepts $a = -3$ and $b = -4$. | <i>Ans.</i> $4x + 3y + 12 = 0$. |
| (g) Passing through (2, 3) and (-2, -3). | <i>Ans.</i> $3x - 2y = 0$. |
| (h) Passing through (3, 4) and (-4, -3). | <i>Ans.</i> $x - y + 1 = 0$. |
| (i) Passing through (2, 3) and slope = -2. | <i>Ans.</i> $2x + y - 7 = 0$. |
| (j) Having the intercepts 2 and -5. | <i>Ans.</i> $\frac{x}{2} - \frac{y}{5} = 1$. |

2. Find the equation of the line passing through the origin parallel to the line $2x - 3y = 4$.

Ans. $2x - 3y = 0$.

3. Find the equation of the line passing through the origin perpendicular to the line $5x + y - 2 = 0$.

Ans. $x - 5y = 0$.

4. Find the equation of the line passing through the point (3, 2) parallel to the line $4x - y - 3 = 0$.

Ans. $4x - y - 10 = 0$.

5. Find the equation of the line passing through the point (3, 0) perpendicular to the line $2x + y - 5 = 0$.

Ans. $x - 2y - 3 = 0$.

6. Find the equation of the line whose intercept on the Y -axis is 5 which passes through the point (6, 3).

Ans. $x + 3y - 15 = 0$.

7. Find the equation of the line whose intercept on the X -axis is 3 which is parallel to the line $x - 4y + 2 = 0$.

Ans. $x - 4y - 3 = 0$.

8. Find the equation of the line passing through the origin and through the intersection of the lines $x - 2y + 3 = 0$ and $x + 2y - 9 = 0$.

Ans. $x - y = 0$.

9. Find the equation of the straight line whose slope is m which passes through the point $P_1(x_1, y_1)$.

Ans. $y - y_1 = m(x - x_1)$.

10. Find the equation of the straight line whose intercepts are a and b .

$$\text{Ans. } \frac{x}{a} + \frac{y}{b} = 1.$$

11. Find the equation of the straight line passing through the points $P_1(x_1, y_1)$ and $P_2(x_2, y_2)$.

$$\text{Ans. } (y_2 - y_1)x - (x_2 - x_1)y + x_2y_1 - x_1y_2 = 0.$$

12. Show that the result of the last problem may be put in the form

$$\frac{x - x_1}{x_2 - x_1} = \frac{y - y_1}{y_2 - y_1}.$$

Hint. Add and subtract x_1y_1 , factor, transpose, and express as a proportion.

45. The equation of the straight line in terms of its slope and the coördinates of any point on the line. In this section and in those immediately following, the Rule in the preceding section is applied to the determination of general forms of the equations of straight lines satisfying pairs of conditions which occur frequently. These general forms will then enable us to write the equations of certain straight lines with the same ease that the equation $y = mx + b$ enables us to write the equation of the straight line whose slope and intercept on the Y -axis are given.

Theorem V. Point-slope form. *The equation of the straight line which passes through the point $P_1(x_1, y_1)$ and has the slope m is*

$$(V) \quad y - y_1 = m(x - x_1).$$

Proof. First step. Let the equation of the given line be

$$(1) \quad Ax + By + C = 0.$$

Second step. Then, by hypothesis,

$$(2) \quad Ax_1 + By_1 + C = 0$$

and

$$(3) \quad -\frac{A}{B} = m.$$

Third step. Solving (2) and (3) for A and C in terms of B , we obtain

$$A = -mB \text{ and } C = B(mx_1 - y_1).$$

Fourth step. Substituting in (1), we have

$$-mBx + By + B(mx_1 - y_1) = 0.$$

Dividing by B and transposing,

$$y - y_1 = m(x - x_1).$$

Q. E. D.

If P_1 lies on the Y -axis, $x_1 = 0$ and $y_1 = b$, so that this equation becomes $y = mx + b$.

46. The equation of the straight line in terms of its intercepts.

We pass now to the consideration of a line determined by two points, and we consider first the case in which the two points lie on the axes. *This section does not, therefore, apply to lines parallel to one of the axes or to lines passing through the origin*, as in the latter case the two points coincide and hence do not determine a line.

Theorem VI. Intercept form. *If a and b are the intercepts of a line on the X - and Y -axes respectively, then the equation of the line is*

$$(VI) \quad \frac{x}{a} + \frac{y}{b} = 1.$$

Proof. First step. Let the equation of the given line be

$$(1) \quad Ax + By + C = 0.$$

Second step. By definition of the intercepts (p. 73), the points $(a, 0)$ and $(0, b)$ lie on the line; hence

$$(2) \quad Aa + C = 0,$$

$$(3) \quad Bb + C = 0.$$

Third step. Solving (2) and (3) for A and B in terms of C , we obtain

$$A = -\frac{1}{a}C \quad \text{and} \quad B = -\frac{1}{b}C.$$

Fourth step. Substituting in (1), we have

$$-\frac{1}{a}Cx - \frac{1}{b}Cy + C = 0.$$

Dividing by C and transposing,

$$\frac{x}{a} + \frac{y}{b} = 1.$$

Q. E. D.

Ex. 1. Write the equation of the locus of $2x - 6y + 3 = 0$ in terms of its intercepts and plot the line.

Solution. Transposing the constant term, we have

$$2x - 6y = -3.$$

Dividing by -3 ,

$$\frac{2x}{-3} + 2y = 1,$$

or

$$\frac{x}{-\frac{3}{2}} + \frac{y}{\frac{1}{2}} = 1.$$

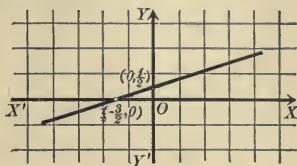

This equation is of the form (VI). Hence

$$a = -\frac{3}{2} \text{ and } b = \frac{1}{2}.$$

Plotting the points $(-\frac{3}{2}, 0)$ and $(0, \frac{1}{2})$ and joining them by a straight line, we have the required line.

47. The equation of the straight line passing through two given points.

Theorem VII. Two-point form. *The equation of the straight line passing through $P_1(x_1, y_1)$ and $P_2(x_2, y_2)$ is*

$$(VII) \quad \frac{x - x_1}{x_2 - x_1} = \frac{y - y_1}{y_2 - y_1}.$$

Proof. Let the equation of the line be

$$(1) \quad Ax + By + C = 0.$$

Then, by hypothesis,

$$(2) \quad Ax_1 + By_1 + C = 0$$

and

$$(3) \quad Ax_2 + By_2 + C = 0.$$

To follow the Rule, p. 93, we must solve (2) and (3) for A and B in terms of C , substitute in (1), and divide by C ; that procedure amounts to *eliminating* A , B , and C from (1), (2), and (3), and that elimination may be more conveniently performed as follows:

Subtract (2) from (1); this gives

$$A(x - x_1) + B(y - y_1) = 0,$$

or

$$(4) \quad A(x - x_1) = -B(y - y_1).$$

Similarly, subtracting (2) from (3), we obtain

$$(5) \quad A(x_2 - x_1) = -B(y_2 - y_1).$$

Dividing (4) by (5), we find

$$\frac{x - x_1}{x_2 - x_1} = \frac{y - y_1}{y_2 - y_1}. \quad \text{Q. E. D.}$$

Corollary. *The condition that three points, $P_1(x_1, y_1)$, $P_2(x_2, y_2)$, and $P_3(x_3, y_3)$ should lie on a line is that*

$$\frac{x_3 - x_1}{x_2 - x_1} = \frac{y_3 - y_1}{y_2 - y_1}.$$

For this is the condition that P_3 should lie on the line (VII) passing through P_1 and P_2 (Corollary, p. 53).

The *method of proving* the corollary should be remembered rather than the corollary itself, as then the condition may be immediately written down from (VII).

PROBLEMS

1. Find, by substitution in the proper formulas, the equations of the lines satisfying the conditions in problem 1, p. 94.

2. Find the equations of the lines fulfilling the following conditions and plot the lines.

- | | |
|--------------------------------------------------------------------------------|----------------------------------|
| (a) Passing through the origin, slope = 3. | <i>Ans.</i> $3x - y = 0$. |
| (b) Passing through $(3, -2)$ and $(0, -1)$. | <i>Ans.</i> $x + 3y + 3 = 0$. |
| (c) Having the intercepts 4 and -3 . | <i>Ans.</i> $3x - 4y - 12 = 0$. |
| (d) \bar{Y} -intercept = 5 and slope = 3. | <i>Ans.</i> $3x - y + 5 = 0$. |
| (e) Passing through $(1, -2)$ and $(3, -4)$. | <i>Ans.</i> $x + y + 1 = 0$. |
| (f) Having the intercepts -1 and -3 . | <i>Ans.</i> $3x + y + 3 = 0$. |
| (g) Passing through $(-\frac{1}{2}, \frac{3}{2})$ and slope = $-\frac{2}{3}$. | <i>Ans.</i> $4x + 6y - 7 = 0$. |
| (h) Passing through $(0, 0)$ and slope = m . | <i>Ans.</i> $y = mx$. |

17 3. Find the equations of the sides of the triangle whose vertices are $(-3, 2)$, $(3, -2)$, and $(0, -1)$.

$$\text{Ans. } 2x + 3y = 0, x + 3y + 3 = 0, \text{ and } x + y + 1 = 0.$$

66 4. Find the equations of the medians of the triangle in problem 3 and show that they meet in a point.

$$\text{Ans. } x = 0, 7x + 9y + 3 = 0, \text{ and } 5x + 9y + 3 = 0.$$

Hint. To show that three lines meet in a point, find the point of intersection of two of them and prove that it lies on the third.

5. Show that the medians of any triangle meet in a point.

Hint. Taking one vertex for origin and one side for the X -axis, the vertices may then be called $(0, 0)$, $(a, 0)$, and (b, c) .

6. Determine whether or not the following sets of points lie on a straight line.

- | | |
|------------------------------------------------------------|------------------|
| (a) $(0, 0)$, $(1, 1)$, $(7, 7)$. | <i>Ans.</i> Yes. |
| (b) $(2, 3)$, $(-4, -6)$, $(8, 12)$. | <i>Ans.</i> Yes. |
| (c) $(3, 4)$, $(1, 2)$, $(5, 1)$. | <i>Ans.</i> No. |
| (d) $(3, -1)$, $(-6, 2)$, $(-\frac{3}{2}, 1)$. | <i>Ans.</i> No. |
| (e) $(5, 6)$, $(\frac{5}{8}, 1)$, $(-1, -\frac{6}{5})$. | <i>Ans.</i> Yes. |
| (f) $(7, 6)$, $(2, 1)$, $(6, -2)$. | <i>Ans.</i> No. |

7. Reduce the following equations to the form (VI) and plot their loci.

- | | |
|-------------------------|-------------------------|
| (a) $2x + 3y - 6 = 0$. | (d) $3x + 4y + 1 = 0$. |
| (b) $x - 3y + 6 = 0$. | (e) $2x - 4y - 7 = 0$. |
| (c) $3x - 4y + 9 = 0$. | (f) $7x - 6y - 3 = 0$. |

8. Find the equations of the lines joining the middle points of the sides of the triangle in problem 3 and show that they are parallel to the sides.

Ans. $4x + 6y + 3 = 0$, $x + 3y = 0$, and $x + y = 0$.

9. Find the equation of the line passing through the origin and through the intersection of the lines $x + 2y = 1$ and $2x - 4y - 3 = 0$.

Ans. $x + 10y = 0$.

10. Show that the diagonals of a square are perpendicular.

Hint. Take two sides for the axes and let the length of a side be a .

11. Show that the line joining the middle points of two sides of a triangle is parallel to the third.

Hint. Choose the axes so that the vertices are $(0, 0)$, $(a, 0)$, and (b, c) .

12. Find the equation of the line passing through the point $(3, -4)$ which has the same slope as the line $2x - y = 3$.

Ans. $2x - y - 10 = 0$.

13. Find the equation of the line passing through the point $(-1, 4)$ which is parallel to the line $3x + y + 1 = 0$.

Ans. $3x + y - 1 = 0$.

14. Two sides of a parallelogram are $2x + 3y - 7 = 0$ and $x - 3y + 4 = 0$. Find the other two sides if one vertex is the point $(3, 2)$.

Ans. $2x + 3y - 12 = 0$ and $x - 3y + 3 = 0$.

15. Find the equation of the line passing through the point $(-2, 3)$ which is perpendicular to the line $x + 2y = 1$.

Ans. $2x - y + 7 = 0$.

16. Show that the three lines $x - 2y = 0$, $x + 2y - 8 = 0$, and $x + 2y - 8 + k(x - 2y) = 0$ meet in a point no matter what value k has.

17. Derive (V) and (VII) by the Rule on p. 53, using Theorem V, p. 35.

18. Derive (VI) and (VII) by the Rule on p. 53, using the theorem that the corresponding sides of similar triangles are proportional.

19. Derive $y = mx + b$ and (V) by the Rule on p. 53, using the definition of the tangent of an acute angle in a right triangle.

20. Derive the equation of the straight line in terms of the perpendicular distance p from the origin to the line and the angle ω which that perpendicular makes with the positive direction of the X -axis.

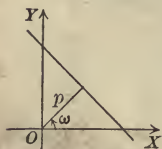

Hint. Find the intercepts in terms of p and ω by solving the right triangles in the figure and substitute in (VI).

$$\text{Ans. } x \cos \omega + y \sin \omega - p = 0.$$

21. What is the locus of (V) if x_1 and y_1 are constant and m arbitrary?

22. What is the locus of (VI) if a is constant and b arbitrary? if b is constant and a arbitrary?

23. Write an equation which represents all lines passing through $(2, -1)$.

24. Write an equation representing all lines whose intercept on the X -axis is 3.

25. Write in two different forms the equation of all lines whose intercept on the Y -axis is -2 .

26. Write an equation representing all lines whose slope is $-\frac{1}{2}$.

27. If the axes are oblique and make an angle of ω , then the equation of a straight line in terms of its inclination α and intercept on the Y -axis b is

$$y = \frac{\sin \alpha}{\sin (\omega - \alpha)} x + b.$$

28. If the angle between the axes is ω , the equation of the line passing through $P_1(x_1, y_1)$ whose inclination is α is

$$y - y_1 = \frac{\sin \alpha}{\sin (\omega - \alpha)} (x - x_1).$$

29. Show that equations (VI) and (VII) hold for oblique coördinates.

48. The normal form of the equation of the straight line.

In the preceding sections the lines considered were determined by two points or by a point and a direction. Both of these methods of determining a line are frequently used in Elementary Geometry, but we have now to consider a line as determined by two conditions which belong essentially to Analytic Geometry.

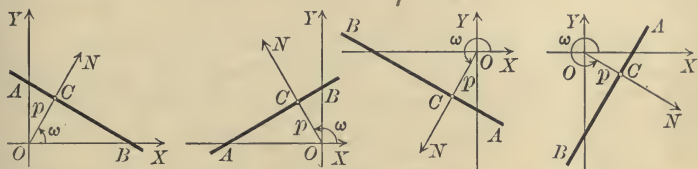

Let AB be any line, and let ON be drawn from the origin perpendicular to AB at C . Let the positive direction on ON be from O toward N , — that is, from the origin toward the line, — and denote the positive directed length OC by p and the positive angle XON , measured, as in Trigonometry (p. 18), from OX as initial line to ON as terminal line, by ω .* Then it is evident from the figures that the position of any line is determined by a pair of values of p and ω , both p and ω being positive and $\omega < 2\pi$.

On the other hand, every line determines a single positive value of p and a single positive value of ω which is less than

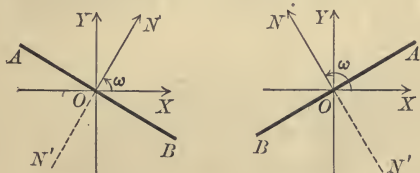

2π , unless $p = 0$. When $p = 0$, however, AB passes through the origin, and the rule given above for the positive direction on ON becomes meaningless. From the figures we see that we can choose for ω either of the angles XON or XON' . When $p = 0$ we shall always suppose that $\omega < \pi$ and that the positive direction on ON is the upward direction.

* ω is not the angle between the directed lines OX and ON , as defined on p. 28.

Theorem VIII. *The normal form* of the equation of the straight line is*

$$(VIII) \quad x \cos \omega + y \sin \omega - p = 0,$$

where p is the perpendicular distance or normal from the origin to the line and ω is the positive angle which that perpendicular makes with the positive direction OX of the X -axis regarded as initial line.

Proof. Let $P(x, y)$ be any point on the given line AB .

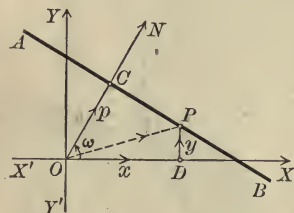

Then since AB is perpendicular to ON , the projection of OP on ON is equal to p (definition, p. 29). By the second theorem of projection (p. 48), the projection of OP on ON is equal to the sum of the projections of OD and DP on ON . Then the condition that P lies on AB is

$$(1) \quad \text{proj. of } OD \text{ on } ON + \text{proj. of } DP \text{ on } ON = p.$$

By the first theorem of projection (p. 30) we have

$$(2) \quad \text{proj. of } OD \text{ on } ON = OD \cos \omega = x \cos \omega,$$

$$(3) \quad \text{proj. of } DP \text{ on } ON = DP \cos \left(\frac{\pi}{2} - \omega \right) = y \sin \omega.$$

For the angle between the directed lines DP and ON equals that between OY and $ON = \frac{\pi}{2} - \omega$.

Substituting from (2) and (3) in (1), we obtain

$$x \cos \omega + y \sin \omega - p = 0.$$

Q. E. D.

To reduce a given equation

$$(4) \quad Ax + By + C = 0$$

to the normal form, we must determine ω and p so that the locus of (4) is identical with the locus of

$$(5) \quad x \cos \omega + y \sin \omega - p = 0.$$

* The designation of this equation is made clear by the definition of the normal in Chapter IX.

Then we must have corresponding coefficients proportional (Theorem III, p. 88).

$$\therefore \frac{\cos \omega}{A} = \frac{\sin \omega}{B} = \frac{-p}{C}.$$

Denote the common value of these ratios by r ; then

$$\begin{aligned} (6) \quad & \cos \omega = rA, \\ (7) \quad & \sin \omega = rB, \text{ and} \\ (8) \quad & -p = rC. \end{aligned}$$

To find r , square (6) and (7) and add; this gives

$$\sin^2 \omega + \cos^2 \omega = r^2(A^2 + B^2).$$

But $\sin^2 \omega + \cos^2 \omega = 1$;

and hence $r^2(A^2 + B^2) = 1$, or

$$(9) \quad r = \frac{1}{\pm \sqrt{A^2 + B^2}}.$$

Equation (8) shows which sign of the radical to use; for since p is positive, r and C must have *opposite* signs, unless $C = 0$. If $C = 0$, then, from (8), $p = 0$, and hence $\omega < \pi$ (p. 101); then $\sin \omega$ is positive, and from (7) r and B must have the *same* signs.

Substituting the value of r from (9) in (6), (7), and (8) gives

$$\cos \omega = \frac{A}{\pm \sqrt{A^2 + B^2}}, \quad \sin \omega = \frac{B}{\pm \sqrt{A^2 + B^2}}, \quad p = -\frac{C}{\pm \sqrt{A^2 + B^2}}.$$

Hence (5) becomes

$$(10) \quad \frac{A}{\pm \sqrt{A^2 + B^2}}x + \frac{B}{\pm \sqrt{A^2 + B^2}}y + \frac{C}{\pm \sqrt{A^2 + B^2}} = 0,$$

which is the normal form of (4). The result of the discussion may be stated in the following

Rule to reduce $Ax + By + C = 0$ to the normal form.

First step. Find the numerical value of $\sqrt{A^2 + B^2}$.

Second step. Give the result of the first step the sign opposite to that of C , or, if $C = 0$, the same sign as that of B .

Third step. Divide the given equation by the result of the second step. The result is the required equation.

The advantages of the normal form of the equation of the straight line over the other forms are twofold. In the first place, *every* line may have its equation in the normal form; whether it is parallel to one of the axes or passes through the origin is immaterial. In the second place, as will be seen in the following section, it enables us to find immediately the distance from a line to a point.

PROBLEMS

1. In what quadrant will ON (Fig., p. 101) lie if $\sin \omega$ and $\cos \omega$ are both positive? both negative? if $\sin \omega$ is positive and $\cos \omega$ negative? if $\sin \omega$ is negative and $\cos \omega$ positive?

2. Find the equations and plot the lines for which

(a) $\omega = 0, p = 5.$

Ans. $x = 5.$

(b) $\omega = \frac{3\pi}{2}, p = 3.$

Ans. $y + 3 = 0.$

(c) $\omega = \frac{\pi}{4}, p = 3.$

Ans. $\sqrt{2}x + \sqrt{2}y - 6 = 0.$

(d) $\omega = \frac{2\pi}{3}, p = 2.$

Ans. $x - \sqrt{3}y + 4 = 0.$

(e) $\omega = \frac{7\pi}{4}, p = 4.$

Ans. $\sqrt{2}x - \sqrt{2}y - 8 = 0.$

3. Reduce the following equations to the normal form and find p and ω .

(a) $3x + 4y - 2 = 0.$

Ans. $p = \frac{2}{5}, \omega = \cos^{-1} \frac{3}{5} = \sin^{-1} \frac{4}{5}.$

(b) $3x - 4y - 2 = 0.$

Ans. $p = \frac{2}{5}, \omega = \cos^{-1} \frac{3}{5} = \sin^{-1} (-\frac{4}{5}).$

(c) $12x - 5y = 0,$

Ans. $p = 0, \omega = \cos^{-1} (-\frac{12}{13}) = \sin^{-1} \frac{5}{13}.$

(d) $2x + 5y + 7 = 0.$

Ans. $p = \frac{7}{\sqrt{29}}, \omega = \cos^{-1} \left(\frac{2}{-\sqrt{29}} \right) = \sin^{-1} \left(\frac{5}{-\sqrt{29}} \right).$

(e) $4x - 3y + 1 = 0.$

Ans. $p = \frac{1}{5}, \omega = \cos^{-1} (-\frac{4}{5}) = \sin^{-1} \frac{3}{5}.$

(f) $4x - 5y + 6 = 0.$

Ans. $p = \frac{6}{\sqrt{41}}, \omega = \cos^{-1} \left(\frac{4}{-\sqrt{41}} \right) = \sin^{-1} \left(\frac{5}{\sqrt{41}} \right).$

4. Find the perpendicular distance from the origin to each of the following lines.

(a) $12x + 5y - 26 = 0.$

Ans. 2.

(b) $x + y + 1 = 0.$

Ans. $\frac{1}{2}\sqrt{2}.$

(c) $3x - 2y - 1 = 0.$

Ans. $\frac{1}{13}\sqrt{13}.$

5. Derive (VIII) when (a) $\frac{\pi}{2} < \omega < \pi$; (b) $\pi < \omega < \frac{3\pi}{2}$; (c) $\frac{3\pi}{2} < \omega < 2\pi$; (d) $p = 0$ and $0 < \omega < \frac{\pi}{2}$.

6. For what values of p and ω will the locus of (VIII) be parallel to the X -axis? the Y -axis? pass through the origin?

7. Find the equations of the lines whose slopes equal -2 , which are at a distance of 5 from the origin.

Ans. $2\sqrt{5}x + \sqrt{5}y - 25 = 0$ and $2\sqrt{5}x + \sqrt{5}y + 25 = 0$.

8. Find the lines whose distance from the origin is 10, which pass through the point (5, 10). *Ans.* $y = 10$ and $4x + 3y = 50$.

9. What is the locus of (VIII) if p is constant and ω arbitrary? if ω is constant and p arbitrary?

10. Write an equation representing all lines whose distance from the origin is 5.

49. The distance from a line to a point. The positive direction on the normal ON drawn through the origin perpendicular to AB (Fig. 1) is *from* O to AB (p. 101); and when AB passes through O (Fig. 2) the positive direction on ON is the *upward* direction.

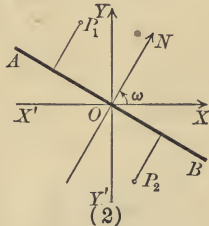
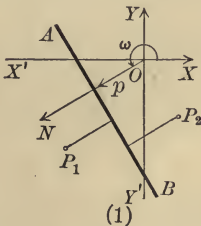

The positive direction on ON is taken to be the *positive direction* on all lines perpendicular to AB . Hence the distance *from* the line AB to the point P_1 is positive if P_1 and the origin are on opposite sides of AB , and negative if P_1 and the origin are on the same side of AB . When AB passes through the origin the distance *from* AB to P_1 is positive if that distance is in the upward direction, and negative if it is in the downward direction. Thus in the figures the distance from AB to P_1 is positive and from AB to P_2 is negative.

Theorem IX. *The distance d from the line*

$$x \cos \omega + y \sin \omega - p = 0$$

to the point $P_1(x_1, y_1)$ is

$$(IX) \quad d = x_1 \cos \omega + y_1 \sin \omega - p.$$

Proof. Let AB be the given line and let ON be perpendicular to AB . By the second theorem of projection (p. 48) we have

proj. of OP_1 on $ON = \text{proj. of } OD \text{ on } ON + \text{proj. of } DP_1 \text{ on } ON.$

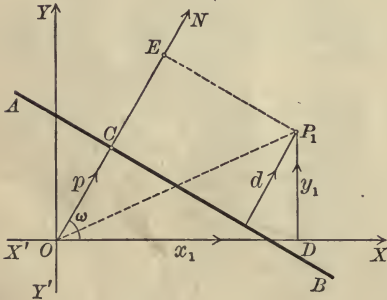

From the figure,

$$\begin{aligned} \text{proj. of } OP_1 \text{ on } ON \\ = OE = p + d. \end{aligned}$$

By the first theorem of projection (p. 30),

$$\begin{aligned} \text{proj. of } OD \text{ on } ON \\ = OD \cos \omega = x_1 \cos \omega, \end{aligned}$$

$$\begin{aligned} \text{proj. of } DP_1 \text{ on } ON \\ = DP_1 \cos \left(\frac{\pi}{2} - \omega \right) \\ = y_1 \sin \omega. \end{aligned}$$

Hence

$$p + d = x_1 \cos \omega + y_1 \sin \omega,$$

and therefore

$$d = x_1 \cos \omega + y_1 \sin \omega - p. \quad \text{Q.E.D.}$$

From this theorem we have at once the

Rule to find the perpendicular distance from a given line to a given point.

First step. Reduce the equation of the given line to the normal form (Rule, p. 103).

Second step. Substitute the coordinates of the given point for x and y in the left-hand side of the equation. The result is the required distance.

The sign of the result will show on which side of the line the point lies.

Ex. 1. Find the distance from the line $4x - 3y + 15 = 0$ to the point $(2, 1)$.

Solution. First step. Reducing the given equation to normal form, we have

$$-\frac{4}{5}x + \frac{3}{5}y - 3 = 0.$$

Second step. Substituting 2 for x and 1 for y , we have

$$d = -\frac{4}{5} \cdot 2 + \frac{3}{5}(1) - 3 = -4.$$

What does the negative sign mean?

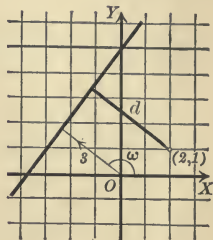

Ex. 2. Prove that the sum of the distances from the legs of an isosceles triangle to any point in the base is constant.

Solution. Take the middle point of the base for origin and the base itself for the X -axis. Then the values of p for the two legs are equal and the values of ω are supplementary. Hence, if the equation of one leg in normal form is

$$x \cos \omega + y \sin \omega - p = 0,$$

then the equation of the other leg is

$$x \cos(\pi - \omega) + y \sin(\pi - \omega) - p = 0,$$

or

$$-x \cos \omega + y \sin \omega - p = 0.$$

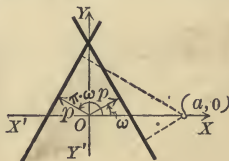

Let $(a, 0)$ be any point in the base. Then the distances from the legs to $(a, 0)$ are respectively $a \cos \omega - p$ and $-a \cos \omega - p$, so that the sum of these distances is $-2p$, that is, a constant.

PROBLEMS

1. Find the distance from the line

(a) $x \cos 45^\circ + y \sin 45^\circ - \sqrt{2} = 0$ to $(5, -7)$.

Ans. $-2\sqrt{2}$.

(b) $\frac{3}{5}x - \frac{4}{5}y - 1 = 0$ to $(2, 1)$.

Ans. $-\frac{3}{5}$.

(c) $3x + 4y + 15 = 0$ to $(-2, 3)$.

Ans. $-\frac{23}{5}$.

(d) $2x - 7y + 8 = 0$ to $(3, -5)$.

Ans. $-\frac{49}{\sqrt{53}}$.

(e) $x - 3y = 0$ to $(0, 4)$.

Ans. $\frac{12}{\sqrt{10}}$.

2. Do the origin and the point $(3, -2)$ lie on the same side of the line $x - y + 1 = 0$?

Ans. Yes.

3. Does the line $2x + 3y + 2 = 0$ pass between the origin and the point $(-2, 3)$? *Ans.* No.

4. Find the lengths of the altitudes of the triangle formed by the lines $2x + 3y = 0$, $x + 3y + 3 = 0$, and $x + y + 1 = 0$.

$$\text{Ans. } \frac{3}{\sqrt{13}}, \frac{6}{\sqrt{10}}, \text{ and } \sqrt{2}.$$

5. Find the distance from the line $Ax + By + C = 0$ to the point $P_1(x_1, y_1)$.

$$\text{Ans. } \frac{Ax_1 + By_1 + C}{\pm \sqrt{A^2 + B^2}}.$$

6. Prove Theorem IX when

(a) $p = 0$, $\omega < \frac{\pi}{2}$; (b) $\frac{\pi}{2} < \omega < \pi$; (c) $\pi < \omega < \frac{3\pi}{2}$; (d) $\frac{3\pi}{2} < \omega < 2\pi$.

7. Find the locus of all points which are equally distant from

$$3x - 4y + 1 = 0 \text{ and } 4x + 3y - 1 = 0.$$

$$\text{Ans. } 7x - y = 0 \text{ and } x + 7y - 2 = 0.$$

8. Find the locus of all points which are twice as far from the line $12x + 5y - 1 = 0$ as from the Y -axis. *Ans.* $14x - 5y + 1 = 0$.

9. Find the locus of points which are k times as far from $4x - 3y + 1 = 0$ as from $5x - 12y = 0$. *Ans.* $(52 - 25k)x - (39 - 60k)y + 13 = 0$.

10. Find the bisectors of the angles formed by the lines in problem 9. *Ans.* $77x - 99y + 13 = 0$ and $27x + 21y + 13 = 0$.

11. Find the distance between the parallel lines,

(a) $\begin{cases} y = 2x + 5, \\ y = 2x - 3. \end{cases}$ *Ans.* $\frac{8}{\sqrt{5}}$. (c) $\begin{cases} 2x - 3y + 4 = 0, \\ 4x - 6y + 9 = 0. \end{cases}$ *Ans.* $\frac{1}{2\sqrt{13}}$.

(b) $\begin{cases} y = -3x + 1, \\ y = -3x + 4. \end{cases}$ *Ans.* $\frac{3}{\sqrt{10}}$. (d) $\begin{cases} y = mx + 3, \\ y = mx - 3. \end{cases}$ *Ans.* $\frac{6}{\sqrt{1+m^2}}$.

12. Derive the normal equation of the line by means of Theorem IX.

13. Prove that the altitudes on the legs of an isosceles triangle are equal.

14. Prove that the three altitudes of an equilateral triangle are equal.

15. Prove that the sum of the distances from the sides of an equilateral triangle to any point is constant.

Hint. Take the center of the triangle for origin, with the X -axis parallel to one side.

16. Find the areas of the triangles formed by the following lines.

- (a) $2x - 3y + 30 = 0, x = 0, x + y = 0.$ Ans. 30.
 (b) $x + y = 2, 3x + 4y - 12 = 0, x - y + 6 = 0.$ Ans. $\frac{4}{3}$.
 (c) $3x - 4y + 12 = 0, x - 3y + 6 = 0, 2x - y = 0.$ Ans. $3\frac{2}{3}$.
 (d) $x + 3y - 3 = 0, 5x - y - 15 = 0, x - y + 1 = 0.$ Ans. 8.

17. Plot the following lines and find the area of the quadrilaterals of which they are the sides.

- (a) $x = y, y = 6, x + y = 0, 3x + 2y - 6 = 0.$ Ans. $16\frac{1}{2}$.
 (b) $x + 2y - 5 = 0, y = 0, x + 4y + 5 = 0, 2x + y - 4 = 0.$ Ans. 18.
 (c) $2x - 4y + 8 = 0, x + y = 0, 2x - y - 4 = 0, 2x + y - 3 = 0.$ Ans. $4\frac{71}{20}$.

50. The angle which a line makes with a second line. The angle between two directed lines has been defined (p. 28) as the angle between their positive directions. When a line is given by means of its equation, no positive direction along the line is fixed. In order to distinguish between the two pairs of equal angles which two intersecting lines make with each other we define the angle which a line makes with a second line to be the positive angle (p. 18) from the second line to the first line.

Thus the angle which L_1 makes with L_2 is the angle θ . We speak always of the "angle which one line makes with a second line," and the use of the phrase "the angle between two lines" should be avoided if those lines are not directed lines. We have thus added a third method of designating angles to those given on p. 18 and p. 28.

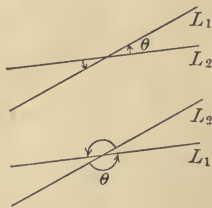

Theorem X. *The angle θ which the line*

$$L_1: A_1x + B_1y + C_1 = 0$$

makes with the line

$$L_2: A_2x + B_2y + C_2 = 0$$

is given by

$$(X) \quad \tan \theta = \frac{A_2B_1 - A_1B_2}{A_1A_2 + B_1B_2}$$

Proof. Let α_1 and α_2 be the inclinations of L_1 and L_2 respectively. Then, since the exterior angle of a triangle equals the sum of the two opposite interior angles, we have

$$\text{In Fig. 1, } \alpha_1 = \theta + \alpha_2, \quad \text{or } \theta = \alpha_1 - \alpha_2,$$

$$\text{In Fig. 2, } \alpha_2 = \pi - \theta + \alpha_1, \quad \text{or } \theta = \pi + (\alpha_1 - \alpha_2).$$

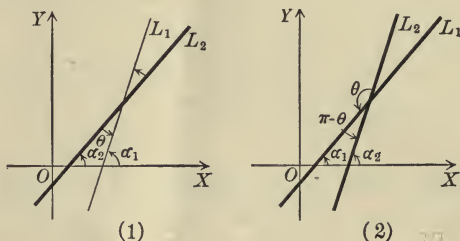

And since (5, p. 20)

$$\tan(\pi + \phi) = \tan \phi,$$

we have, in either case,

$$\begin{aligned} \tan \theta &= \tan(\alpha_1 - \alpha_2) \\ &= \frac{\tan \alpha_1 - \tan \alpha_2}{1 + \tan \alpha_1 \tan \alpha_2}. \quad (\text{by 13, p. 20}) \end{aligned}$$

But $\tan \alpha_1$ is the slope of L_1 and $\tan \alpha_2$ is the slope of L_2 ; hence (Corollary I, p. 86)

$$\tan \theta = \frac{-\frac{A_1}{B_1} + \frac{A_2}{B_2}}{1 + \left(-\frac{A_1}{B_1}\right)\left(-\frac{A_2}{B_2}\right)}.$$

$$\text{Reducing, we get } \tan \theta = \frac{A_2 B_1 - A_1 B_2}{A_1 A_2 + B_1 B_2}.$$

Q. E. D.

Corollary. If m_1 and m_2 are the slopes of two lines, then the angle θ which the first line makes with the second is given by

$$\tan \theta = \frac{m_1 - m_2}{1 + m_1 m_2}.$$

Ex. 1. Find the angles of the triangle formed by the lines whose equations are

$$L: 2x - 3y - 6 = 0,$$

$$M: 6x - y - 6 = 0,$$

$$N: 6x + 4y - 25 = 0.$$

Solution. To see which angles formed by the given lines are the angles of the triangle, we plot the lines, obtaining the triangle ABC . A is the angle which M makes with L , so that M takes the place of L_1 in Theorem X and L of L_2 .

Hence

$$A_1 = 6, B_1 = -1;$$

$$A_2 = 2, B_2 = -3.$$

Then

$$\tan A = \frac{A_2 B_1 - A_1 B_2}{A_1 A_2 + B_1 B_2} = \frac{-2 + 18}{12 + 3} = \frac{16}{15},$$

and hence

$$A = \tan^{-1}\left(\frac{16}{15}\right).$$

B is the angle which L makes with N , and by Corollary III, p. 87, $B = \frac{\pi}{2}$.
 C is the angle which N makes with M , so that if

$$\tan C = \frac{A_2 B_1 - A_1 B_2}{A_1 A_2 + B_1 B_2},$$

we must set

$$A_1 = 6, B_1 = 4;$$

$$A_2 = 6, B_2 = -1.$$

Hence

$$\tan C = \frac{24 + 6}{36 - 4} = \frac{30}{32} = \frac{15}{16},$$

and

$$C = \tan^{-1}\left(\frac{15}{16}\right).$$

We may verify these results. For if $B = \frac{\pi}{2}$, then $A = \frac{\pi}{2} - C$; and hence (6, p. 20, and 1, p. 19) $\tan A = \cot C = \frac{1}{\tan C}$, which is true for the values found.

Ex. 2. Find the equation of the line through $(3, 5)$ which makes an angle of $\frac{\pi}{3}$ with the line $x - y + 6 = 0$.

Solution. Let m_1 be the slope of the required line. Then its equation is (Theorem V, p. 95)

$$(1) \quad y - 5 = m_1(x - 3).$$

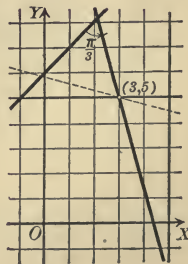
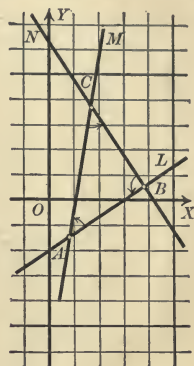

The slope of the given line is $m_2 = 1$, and since the angle which (1) makes with the given line is $\frac{\pi}{3}$, we have (by the Corollary),

$$\tan \frac{\pi}{3} = \frac{m_1 - 1}{1 + m_1},$$

or

$$\sqrt{3} = \frac{m_1 - 1}{1 + m_1},$$

whence

$$m_1 = \frac{1 + \sqrt{3}}{1 - \sqrt{3}} = -(2 + \sqrt{3}).$$

Substituting in (1), we obtain

$$y - 5 = -(2 + \sqrt{3})(x - 3),$$

or

$$(2 + \sqrt{3})x + y - (11 + 3\sqrt{3}) = 0.$$

In Plane Geometry there would be two solutions of this problem, — the line just obtained and the dotted line of the figure. Why must the latter be excluded here?

PROBLEMS

1. Find the angle which the line $3x - y + 2 = 0$ makes with $2x + y - 2 = 0$; also the angle which the second line makes with the first, and show that these angles are supplementary.

Ans. $\frac{3\pi}{4}, \frac{\pi}{4}$.

2. Find the angle which the line

- (a) $2x - 5y + 1 = 0$ makes with the line $x - 2y + 3 = 0$.
- (b) $x + y + 1 = 0$ makes with the line $x - y + 1 = 0$.
- (c) $3x - 4y + 2 = 0$ makes with the line $x + 3y - 7 = 0$.
- (d) $6x - 3y + 3 = 0$ makes with the line $x = 6$.
- (e) $x - 7y + 1 = 0$ makes with the line $x + 2y - 4 = 0$.

In each case plot the lines and mark the angle found by a small arc.

Ans. (a) $\tan^{-1}(-\frac{1}{2})$; (b) $\frac{\pi}{2}$; (c) $\tan^{-1}(\frac{13}{9})$; (d) $\tan^{-1}(-\frac{1}{2})$; (e) $\tan^{-1}(\frac{9}{13})$.

3. Find the angles of the triangle whose sides are $x + 3y - 4 = 0$, $3x - 2y + 1 = 0$, and $x - y + 3 = 0$. Ans. $\tan^{-1}(-\frac{1}{3})$, $\tan^{-1}(\frac{1}{3})$, $\tan^{-1}(2)$.

Hint. Plot the triangle to see which angles formed by the given lines are the angles of the triangle.

4. Find the exterior angles of the triangle formed by the lines $5x - y + 3 = 0$, $y = 2$, $x - 4y + 3 = 0$. Ans. $\tan^{-1}(5)$, $\tan^{-1}(-\frac{1}{4})$, $\tan^{-1}(-\frac{19}{4})$.

5. Find one exterior angle and the two opposite interior angles of the triangle formed by the lines $2x - 3y - 6 = 0$, $3x + 4y - 12 = 0$, $x - 3y + 6 = 0$. Verify the results by formula 12, p. 20.

6. Find the angles of the triangle formed by $3x + 2y - 4 = 0$, $x - 3y + 6 = 0$, and $4x - 3y - 10 = 0$. Verify the results by the formula

$$\tan A + \tan B + \tan C = \tan A \tan B \tan C, \text{ if } A + B + C = 180^\circ.$$

7. Find the line passing through the given point and making the given angle with the given line.

(a) $(2, 1), \frac{\pi}{4}, 2x - 3y + 2 = 0.$ *Ans.* $5x - y - 9 = 0.$

(b) $(1, -3), \frac{3\pi}{4}, x + 2y + 4 = 0.$ *Ans.* $3x + y = 0.$

(c) $(2, -5), \frac{\pi}{4}, x + 3y - 8 = 0.$ *Ans.* $x - 2y - 12 = 0.$

(d) $(x_1, y_1), \phi, y = mx + b.$ *Ans.* $y - y_1 = \frac{m + \tan \phi}{1 - m \tan \phi} (x - x_1).$

(e) $(x_1, y_1), \phi, Ax + By + C = 0.$ *Ans.* $y - y_1 = \frac{B \tan \phi - A}{A \tan \phi + B} (x - x_1).$

8. Show from a figure that it is impossible to draw a line through the intersection of two lines and "making equal angles with those lines" in the sense in which we have defined "the angle which one line makes with a second line." Prove the same thing by formula (X). How are the bisectors of the angles of two lines to be defined?

9. Given two lines $L_1: 3x - 4y - 3 = 0$ and $L_2: 4x - 3y + 12 = 0$; find the equation of the line passing through their point of intersection such that the angle it makes with L_1 is equal to the angle L_2 makes with it.

$$\textit{Ans. } 7x - 7y + 9 = 0.$$

51. Systems of straight lines. An equation of the first degree in x and y which contains a single arbitrary constant will represent an infinite number of lines, for the locus of the equation will be a straight line for any value of the constant, and the locus will be different for different values of the constant.

The lines represented by an equation of the first degree which contains an arbitrary constant are said to form a **system**. An equation which represents all of the lines satisfying a single condition must contain an arbitrary constant, for there is an infinite number of lines satisfying a single condition; hence a single geometrical condition defines a system of lines.

Thus the equation $y = 2x + b$, where b is an arbitrary constant, represents the system of lines having the slope 2; and the equation $y - 5 = m(x - 3)$, where m is an arbitrary constant, represents the system of lines passing through $(3, 5)$.

Second rule to find the equation of a straight line satisfying two conditions.

First step. Write the equation of the system of lines satisfying one condition.

Second step. Determine the arbitrary constant in the equation found in the first step so that the other condition is satisfied.

Third step. Substitute the result of the second step in the result of the first step. This gives the required equation.

This rule is, in general, easier of application than the rule on p. 93. It has already been applied in solving Ex. 2, p. 111, and will find constant application in the following sections. The number of lines satisfying the conditions imposed will be the number of real values of the arbitrary constant obtained in the second step.

Ex. 1. Find the equations of the straight lines having the slope $\frac{3}{4}$ and intersecting the circle $x^2 + y^2 = 4$ in but one point.

Solution. First step. The equation

$$y = \frac{3}{4}x + b$$

represents the system of lines whose slopes are $\frac{3}{4}$ (Theorem I, p. 58).

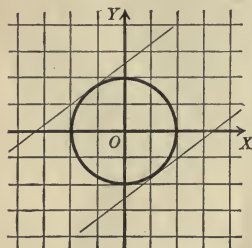

Second step. The coordinates of the intersection of the line and circle are found by solving their equations simultaneously (Rule, p. 76). Substituting the value of y in the line in the equation of the circle, we have

$$x^2 + \left(\frac{3}{4}x + b\right)^2 = 4,$$

$$\text{or } 25x^2 + 24bx + (16b^2 - 64) = 0.$$

The roots of this equation, by hypothesis, must be equal; hence the discriminant must vanish (Theorem II, p. 3); that is,

$$576b^2 - 100(16b^2 - 64) = 0,$$

whence

$$b = \pm \frac{5}{2}.$$

Third step. Substitute these values of b in the equation of the first step. We thus obtain the two solutions

$$y = \frac{3}{4}x + \frac{5}{2}$$

and

$$y = \frac{3}{4}x - \frac{5}{2}.$$

PROBLEMS

1. Write the equations of the systems of lines defined by the following conditions.

- Passing through $(-2, 3)$.
- Having the slope $-\frac{2}{3}$.
- Distance from the origin is 3.
- Having the intercept on the Y -axis $= -3$.
- Passing through $(6, -1)$.
- Having the intercept on the X -axis $= 6$.
- Having the slope $\frac{1}{2}$.
- Having the intercept on the Y -axis $= 5$.
- Distance from the origin $= 4$.

2. What geometric conditions define the systems of lines represented by the following equations?

- $2x - 3y + 4k = 0$.
- $kx - 3y - 7 = 0$.
- $x + y - k = 0$.
- $x + k = 0$.
- $x + 2ky - 3 = 0$.
- $2kx - 3y + 2 = 0$.
- $x \cos \alpha + y \sin \alpha + 5 = 0$.

Hint. Reduce the given equation to one of the well-known forms of the equation of the first degree.

3. Determine k so that

- the line $2x - 3y + k = 0$ passes through $(-2, 1)$. *Ans.* $k = 7$.
- the line $2kx - 5y + 3 = 0$ has the slope 3. *Ans.* $k = \frac{1}{2}$.
- the line $x + y - k = 0$ passes through $(3, 4)$. *Ans.* $k = 7$.
- the line $3x - 4y + k = 0$ has intercept on X -axis $= 2$.
Ans. $k = -6$.
- the line $x - 3ky + 4 = 0$ has intercept on Y -axis $= -3$.
Ans. $k = -\frac{4}{3}$.
- the line $4x - 3y + 6k = 0$ is distant three units from the origin.
Ans. $k = \pm \frac{5}{2}$.

4. Find the equations of the straight lines with the slope $-\frac{5}{12}$ which cut the circle $x^2 + y^2 = 1$ in but one point. *Ans.* $5x + 12y = \pm 13$.

5. Find the equations of the lines passing through the point $(1, 2)$ which cut the circle $x^2 + y^2 = 4$ in but one point. *Ans.* $y = 2$ and $4x + 3y = 10$.

6. Find the equation of the straight line passing through $(-2, 5)$ which makes an angle of 45° with the Y -axis. *Ans.* $x + y - 3 = 0$.

7. Find the equation of the straight line which passes through the point $(2, -1)$ and which is at a distance of two units from the origin.

$$\text{Ans. } x = 2 \text{ and } 3x - 4y = 10.$$

8. Find the equation of the straight line whose slope is $\frac{3}{4}$ such that the distance from the line to the point $(2, 4)$ is 2. Ans. $3x - 4y = 0$.

52. The system of lines parallel to a given line.

Theorem XI. *The system of lines parallel to a given line*

$$Ax + By + C = 0$$

is represented by

$$(XI) \quad Ax + By + k = 0,$$

where k is an arbitrary constant.

Proof. All of the lines of the system represented by (XI) are parallel to the given line (Corollary II, p. 87). It remains to be shown that *all* lines parallel to the given line are represented by (XI). Any line parallel to the given line is determined by some point $P_1(x_1, y_1)$ through which it passes. If P_1 lies on (XI),

then

$$Ax_1 + By_1 + k = 0;$$

and hence

$$k = -Ax_1 - By_1.$$

That is, the value of k may be chosen so that the locus of (XI) passes through *any* point P_1 . Then (XI) represents *all* lines parallel to the given line. Q. E. D.

It should be noticed that the coefficients of x and y in (XI) are the same as those of the given equation.

Ex. 1. Find the equation of the line through the point $P_1(3, -2)$ parallel to the line $L_1: 2x - 3y - 4 = 0$.

Solution. Apply the Rule, p. 114.

First step. The system of lines parallel to the given line is

$$2x - 3y + k = 0.$$

Second step. The required line passes through P_1 ; hence

$$2 \cdot 3 - 3(-2) + k = 0,$$

and therefore $k = -12$.

Third step. Substituting this value of k , the required equation is

$$2x - 3y - 12 = 0$$

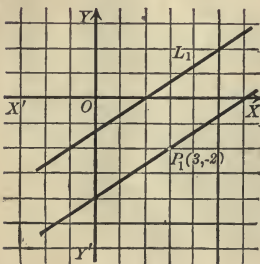

53. The system of lines perpendicular to a given line.

Theorem XII. *The system of lines perpendicular to the given line*

$$Ax + By + C = 0$$

is represented by

$$(XII) \quad Bx - Ay + k = 0,$$

where k is an arbitrary constant.

Proof. All of the lines of the system represented by (XII) are perpendicular to the given line, for (Corollary III, p. 87) $AB - BA = 0$. It remains to be shown that *all* lines perpendicular to the given line are represented by (XII). Any line perpendicular to the given line is determined by some point $P_1(x_1, y_1)$ through which it passes. If P_1 lies on (XII), then

$$Bx_1 - Ay_1 + k = 0,$$

whence

$$k = Ay_1 - Bx_1.$$

That is, the value of k may be chosen so that the locus of (XII) passes through *any* point P_1 . Then (XII) represents all lines perpendicular to the given line. Q. E. D.

Notice that the coefficients of x and y in (XII) are respectively the coefficients of y and x in the given equation with the sign of one of them changed.

Ex. 1. Find the equation of the line through the point $P_1(-1, 3)$ perpendicular to the line $L_1: 5x - 2y + 3 = 0$.

Solution. Apply the Rule, p. 114.

First step. The equation of the system of lines perpendicular to the given line is

$$2x + 5y + k = 0.$$

Second step. The required line passes through P_1 ; hence

$$2(-1) + 5 \cdot 3 + k = 0,$$

or

$$k = -13.$$

Third step. Substitute this value of k . The required equation is then

$$2x + 5y - 13 = 0.$$

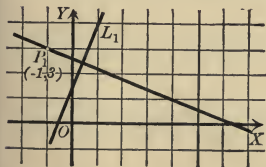

54. The system of lines passing through the intersection of two given lines.

Theorem XIII. *The system of lines passing through the intersection of two given lines*

$$L_1 : A_1x + B_1y + C_1 = 0$$

and

$$L_2 : A_2x + B_2y + C_2 = 0$$

is represented by the equation

$$(XIII) \quad A_1x + B_1y + C_1 + k(A_2x + B_2y + C_2) = 0,$$

where k is an arbitrary constant.

Proof. All of the lines represented by (XIII) pass through the intersection of L_1 and L_2 . For let $P_1(x_1, y_1)$ be the intersection of L_1 and L_2 . Then (Corollary, p. 53)

$$A_1x_1 + B_1y_1 + C_1 = 0$$

and

$$A_2x_1 + B_2y_1 + C_2 = 0.$$

Multiply the second equation by k and add to the first. This gives

$$A_1x_1 + B_1y_1 + C_1 + k(A_2x_1 + B_2y_1 + C_2) = 0.$$

But this is the condition that P_1 lies on (XIII).

That *all* lines through the intersection of L_1 and L_2 are represented by (XIII) follows as in the proofs of Theorems XI and XII.

Q. E. D.

Corollary. *If L_1 and L_2 are parallel, then (XIII) represents the system of lines parallel to L_1 and L_2 .*

For if L_1 and L_2 are parallel, then

$$\frac{A_1}{A_2} = \frac{B_1}{B_2},$$

and hence

$$\frac{A_1}{kA_2} = \frac{B_1}{kB_2}.$$

By composition,

$$\frac{A_1 + kA_2}{A_1} = \frac{B_1 + kB_2}{B_1}.$$

Hence L_1 and (XIII) are parallel (Corollary II, p. 87).

Notice that (XIII) is formed by multiplying the equation of L_2 by k and adding it to the equation of L_1 .

Ex. 1. Find the equation of the line passing through $P_1(2, 1)$ and the intersection of $L_1: 3x - 5y - 10 = 0$ and $L_2: x + y + 1 = 0$.

Solution. Apply the Rule, p. 114. The system of lines passing through the intersection of the given lines is represented by

$$3x - 5y - 10 + k(x + y + 1) = 0.$$

If P_1 lies on this line, then

$$6 - 5 - 10 + k(2 + 1 + 1) = 0;$$

whence $k = \frac{9}{4}$.

Substituting this value of k and simplifying, we have the required equation

$$21x - 11y - 31 = 0.$$

Ex. 2. Find the equation of the line passing through the intersection of $L_1: 2x + y + 1 = 0$ and $L_2: x - 2y + 1 = 0$ and parallel to $L_3: 4x - 3y - 7 = 0$.

Solution. Apply the Rule, p. 114. The equation of every line through the intersection of the first two given lines has the form

$$2x + y + 1 + k(x - 2y + 1) = 0,$$

$$\text{or } (2 + k)x + (1 - 2k)y + (1 + k) = 0.$$

If this line is parallel to the third line (Corollary II, p. 87),

$$\frac{2 + k}{4} = \frac{1 - 2k}{-3};$$

whence $k = 2$.

Substituting and simplifying, we obtain

$$4x - 3y + 3 = 0.$$

The geometrical significance of the value of k in Theorem XIII is given most simply when L_1 and L_2 are in normal form.

Theorem XIV. *The ratio of the distances from*

$$L_1: x \cos \omega_1 + y \sin \omega_1 - p_1 = 0$$

and

$$L_2: x \cos \omega_2 + y \sin \omega_2 - p_2 = 0$$

to any point of the line

$$L: x \cos \omega_1 + y \sin \omega_1 - p_1 + k(x \cos \omega_2 + y \sin \omega_2 - p_2) = 0$$

is constant and equal to $-k$.

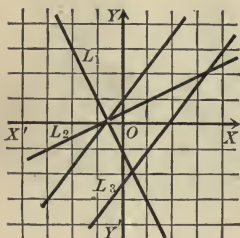
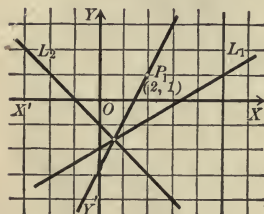

Proof. Let $P_1(x_1, y_1)$ be any point on L . Then

$$x_1 \cos \omega_1 + y_1 \sin \omega_1 - p_1 + k(x_1 \cos \omega_2 + y_1 \sin \omega_2 - p_2) = 0,$$

and hence
$$-k = \frac{x_1 \cos \omega_1 + y_1 \sin \omega_1 - p_1}{x_1 \cos \omega_2 + y_1 \sin \omega_2 - p_2}.$$

The numerator of this fraction is the distance from L_1 to P_1 , and the denominator is the distance from L_2 to P_1 (Theorem IX, p. 106). Hence $-k$ is the ratio of the distances from L_1 and L_2 to any point on L . Q.E.D.

Corollary. *If $k = \pm 1$, then L is the bisector of one of the angles formed by L_1 and L_2 . That is, the equations of the bisectors of the angles between two lines are found by reducing their equations to the normal form and adding and subtracting them.*

For when $k = \pm 1$ the numerical values of the distances from L_1 and L_2 to any point of L are equal.

The angle formed by L_1 and L_2 in which the origin lies, or its vertical angle, is called an **internal angle** of L_1 and L_2 ; and either of the other angles formed by L_1 and L_2 is called an **external angle** of those lines. From the rule giving the *sign* of the distance from a line to a point (p. 105) it follows that L lies in the internal angles of L_1 and L_2 when k is negative, and in the external angles when k is positive. If the origin lies on L_1 or L_2 , the lines must in each case be plotted and the angles in which k is positive found from the figure.

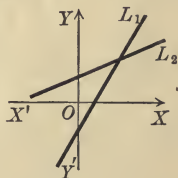

PROBLEMS

1. Find the equation of the line passing through the intersection of $2x - 3y + 2 = 0$ and $3x - 4y - 2 = 0$, (without finding the point of intersection,) which

- (a) passes through the origin.
- (b) is parallel to $5x - 2y + 3 = 0$.
- (c) is perpendicular to $3x - 2y + 4 = 0$.

Ans. (a) $5x - 7y = 0$; (b) $5x - 2y - 50 = 0$; (c) $2x + 3y - 58 = 0$.

2. Find the equations of the lines which pass through the vertices of the triangle formed by the lines $2x - 3y + 1 = 0$, $x - y = 0$, and $3x + 4y - 2 = 0$ which are

(a) parallel to the opposite sides.

(b) perpendicular to the opposite sides.

Ans. (a) $3x + 4y - 7 = 0$, $14x - 21y + 2 = 0$, $17x - 17y + 5 = 0$;

(b) $4x - 3y - 1 = 0$, $21x + 14y - 10 = 0$, $17x + 17y - 9 = 0$.

3. Find the bisectors of the angles formed by the lines $4x - 3y - 1 = 0$ and $3x - 4y + 2 = 0$, and show that they are perpendicular.

Ans. $7x - 7y + 1 = 0$ and $x + y - 3 = 0$.

4. Find the equations of the bisectors of the angles formed by the lines $5x - 12y + 10 = 0$ and $12x - 5y + 15 = 0$. Verify the results by Theorem X.

5. Find the locus of a point the ratio of whose distances from the lines $4x - 3y + 4 = 0$ and $5x + 12y - 8 = 0$ is 13 to 5. *Ans.* $9x + 9y - 4 = 0$.

6. Find the bisectors of the interior angles of the triangle formed by the lines $4x - 3y = 12$, $5x - 12y - 4 = 0$, and $12x - 5y - 13 = 0$. Show that they meet in a point.

Ans. $7x - 9y - 16 = 0$, $7x + 7y - 9 = 0$, $112x - 64y - 221 = 0$.

7. Find the bisectors of the interior angles of the triangle formed by the lines $5x - 12y = 0$, $5x + 12y + 60 = 0$, and $12x - 5y - 60 = 0$, and show that they meet in a point.

Ans. $2y + 5 = 0$, $17x + 7y = 0$, $17x - 17y - 60 = 0$.

8. The sides of a triangle are $3x + 4y - 12 = 0$, $3x - 4y = 0$, and $4x + 3y + 24 = 0$. Show that the bisector of the interior angle at the vertex formed by the first two lines and the bisectors of the exterior angles at the other vertices meet in a point.

9. Find the equation of the line passing through the intersection of $x + y - 2 = 0$ and $x - y + 6 = 0$ and through the intersection of $2x - y + 3 = 0$ and $x - 3y + 2 = 0$. *Ans.* $19x + 3y + 26 = 0$.

Hint. The systems of lines passing through the points of intersection of the two pairs of lines are

$$x + y - 2 + k(x - y + 6) = 0$$

and

$$2x - y + 3 + k'(x - 3y + 2) = 0.$$

These lines will coincide if (Theorem III, p. 88)

$$\frac{1+k}{2+k'} = \frac{1-k}{-1-3k'} = \frac{-2+6k}{3+2k'}.$$

Letting ρ be the common value of these ratios, we obtain

$$1+k = 2\rho + \rho k',$$

$$1-k = -\rho - 3\rho k',$$

and

$$-2+6k = 3\rho + 2\rho k'.$$

From these equations we can eliminate the terms in $\rho k'$ and ρ , and thus find the value of k which gives that line of the first system which also belongs to the second system.

10. Find the equation of the line passing through the intersection of $2x + 5y - 3 = 0$ and $3x - 2y - 1 = 0$ and through the intersection of $x - y = 0$ and $x + 3y - 6 = 0$.
Ans. $43x - 35y - 12 = 0$.

A figure composed of four lines intersecting in six points is called a **complete quadrilateral**. The six vertices determine three diagonals of which two are the diagonals of the ordinary quadrilateral formed by the four lines.

11. Find the equations of the three diagonals of the complete quadrilateral formed by the lines $x + 2y = 0$, $3x - 4y + 2 = 0$, $x - y + 3 = 0$, and $3x - 2y + 4 = 0$.
Ans. $2x - y + 1 = 0$, $x + 2 = 0$, $5x - 6y + 8 = 0$.

12. Show that the bisectors of the angles of any two lines are perpendicular.

13. Find a geometrical interpretation of k in (XI) and (XII).

14. Find the geometrical interpretation of k in (XIII) when L_1 and L_2 are not in normal form.

15. Show that the bisectors of the interior angles of any triangle meet in a point.

16. Show that the bisectors of two exterior angles of a triangle and of the third interior angle meet in a point.

55. The parametric equations of the straight line. The angles α and β between a line directed upward* and the coordinate axes (p. 28) are called the **direction angles** of the line. Their cosines, $\cos \alpha$ and $\cos \beta$, are called the **direction cosines** of the line and satisfy the relation

$$(1) \quad \cos^2 \alpha + \cos^2 \beta = 1.$$

For (Theorem I, p. 28) $\cos \beta = \sin \alpha$ and $\sin^2 \alpha + \cos^2 \alpha = 1$.

Given a line with direction angles α and β passing through $P_1(x_1, y_1)$. Let $P(x, y)$ be any point on this line and denote the variable directed length P_1P by ρ . The projections of P_1P on the axes are respectively (Theorem III, p. 31)

$$x - x_1 \text{ and } y - y_1,$$

or (Theorem II, p. 30)

$$\rho \cos \alpha \text{ and } \rho \cos \beta.$$

* If the line is horizontal we suppose that it is directed to the right, so $\alpha = 0$ and $\beta = \frac{\pi}{2}$.

Hence $x - x_1 = \rho \cos \alpha$ and $y - y_1 = \rho \cos \beta$;

whence $x = x_1 + \rho \cos \alpha$
 $y = y_1 + \rho \cos \beta$.

Hence we have

Theorem XV. Parametric form. *The coördinates of any point $P(x, y)$ on the line through a given point $P_1(x_1, y_1)$ whose direction angles are α and β are given by*

$$(XV) \quad \begin{cases} x = x_1 + \rho \cos \alpha, \\ y = y_1 + \rho \cos \beta, \end{cases}$$

where ρ denotes the variable directed length P_1P .

Equations (XV) are called the **parametric equations** of the straight line because they express the variable coördinates of any point (x, y) on the line in terms of a single variable parameter ρ . As ρ varies from $-\infty$ to $+\infty$ the point $P(x, y)$ describes the line in the positive direction. These equations are important in dealing with problems which involve the distances from a point P_1 on a line to the intersections of that line with a given curve.

Theorem XVI. Symmetric form. *The equation of a straight line in terms of the coördinates of a point $P_1(x_1, y_1)$ on the line and its direction cosines is*

$$(XVI) \quad \frac{x - x_1}{\cos \alpha} = \frac{y - y_1}{\cos \beta}.$$

Hint. Solve (XV) for ρ and equate the two values obtained.

Theorem XVII. *The direction cosines of the line*

$$Ax + By + C = 0$$

are $\cos \alpha = \frac{-B}{\pm \sqrt{A^2 + B^2}}$, $\cos \beta = \frac{A}{\pm \sqrt{A^2 + B^2}}$

when the sign of the radical is the same as that of A .

Proof. Let $P_1(x_1, y_1)$ be a point on the given line. Then (Corollary, p. 53)

$$Ax_1 + By_1 + C = 0.$$

Subtracting from the given equation, we obtain

$$A(x - x_1) + B(y - y_1) = 0.$$

Transpose the second term and divide by $-AB$; this gives

$$\frac{x - x_1}{-B} = \frac{y - y_1}{A}.$$

Dividing this equation by (XVI), we have

$$\frac{\cos \alpha}{-B} = \frac{\cos \beta}{A}.$$

Let r denote the common value of these ratios. Then

$$\cos \alpha = -Br \text{ and } \cos \beta = Ar.$$

Squaring and adding,

$$\cos^2 \alpha + \cos^2 \beta = (A^2 + B^2)r^2.$$

Then from (1), p. 123, $r = \frac{1}{\pm \sqrt{A^2 + B^2}}$,

and hence

$$(2) \quad \cos \alpha = \frac{-B}{\pm \sqrt{A^2 + B^2}} \text{ and } \cos \beta = \frac{A}{\pm \sqrt{A^2 + B^2}}.$$

The sign of the radical must be the same as that of A . Q. E. D.

[For since the line is directed upward, $\beta \leq \frac{\pi}{2}$, and hence $\cos \beta$ is positive.]

Corollary. *If $\cos \alpha$ and $\cos \beta$ are proportional to two numbers a and b , then*

$$\cos \alpha = \frac{a}{\pm \sqrt{a^2 + b^2}}, \quad \cos \beta = \frac{b}{\pm \sqrt{a^2 + b^2}}.$$

The sign of the radical must be the same as that of b .

To reduce the equation of a given straight line to the symmetrical or parametric form it is necessary to know the coördinates of some point on the line (which may be found by the Rule, p. 60) and its direction cosines (which are given by Theorem XVII). Then we can write the required equations by Theorem XV or XVI.

Ex. 1. Plot the line whose parametric equations are $x = 2 - \frac{3}{5}\rho$ and $y = 1 + \frac{4}{5}\rho$.

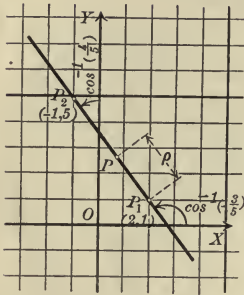

Solution. Comparing with (XV) we see that $P_1(2, 1)$ is a point on the line. A second point will enable us to plot the line. We have at once the table

ρ	x	y
0	2	1
5	-1	5

Hence the line joining the points $P_1(2, 1)$ and $P_2(-1, 5)$ is the required line.

(x, y) , or $(2 - \frac{3}{5}\rho, 1 + \frac{4}{5}\rho)$, are the coördinates of that variable point P on the line whose distance from P_1 is the variable ρ .

Ex. 2. Given the circle $C: x^2 + y^2 = 25$ and the line whose parametric equations are $x = 5 - \frac{3}{5}\rho$ and $y = -3 + \frac{4}{5}\rho$; find the product of the distances from $P_1(5, -3)$ to the points of intersection of the line with C , and the middle point of the chord formed by the line.

Solution. By Theorem XV the coördinates of any point on the line are $(5 - \frac{3}{5}\rho, -3 + \frac{4}{5}\rho)$, where ρ denotes the distance from P_1 to that point. If that point lies on C (Corollary, p. 53),

$$(5 - \frac{3}{5}\rho)^2 + (-3 + \frac{4}{5}\rho)^2 = 25,$$

or, simplifying,

$$(3) \quad \rho^2 - \frac{54}{5}\rho + 9 = 0.$$

The roots of this quadratic are the directed lengths $\rho_1 = P_1P_2$ and $\rho_2 = P_1P_3$, where P_2 and P_3 are the points of intersection of the line and circle. For if $P_2(5 - \frac{3}{5}\rho_1, -3 + \frac{4}{5}\rho_1)$ is on the circle,

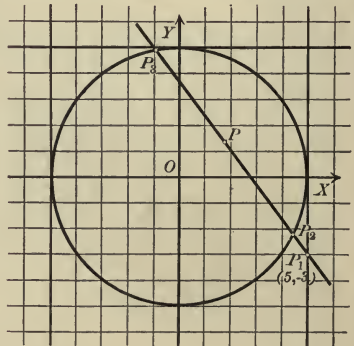

$$(5 - \frac{3}{5}\rho_1)^2 + (-3 + \frac{4}{5}\rho_1)^2 = 25,$$

or

$$\rho_1^2 - \frac{54}{5}\rho_1 + 9 = 0.$$

Hence ρ_1 , and similarly ρ_2 , is a root of (3).

The product of these distances is therefore 9 (Theorem I, p. 3).

Half the sum of these roots is P_1P , or $\frac{27}{5}$ (Theorem I, p. 3). For $\rho = \frac{27}{5}$ we have $x = \frac{44}{5}$ and $y = \frac{32}{5}$, so the middle point of the chord is the point $P(\frac{44}{5}, \frac{32}{5})$.

PROBLEMS

1. Plot the following lines:

$$(a) \begin{cases} x = 2 + \frac{4}{3}\rho, \\ y = -1 + \frac{2}{3}\rho. \end{cases}$$

$$(c) \begin{cases} x = -3 - \frac{11}{3}\rho, \\ y = \frac{5}{3}\rho. \end{cases}$$

$$(b) \begin{cases} x = 1 - \frac{5}{3}\rho, \\ y = 2 + \frac{1}{3}\rho. \end{cases}$$

$$(d) \begin{cases} x = -1 - \frac{1}{\sqrt{5}}\rho, \\ y = 5 + \frac{2}{\sqrt{5}}\rho. \end{cases}$$

2. Prove that if $\cos \alpha$ and $\cos \beta$ are the direction cosines of a line directed upward, then $-\cos \alpha$ and $-\cos \beta$ are the direction cosines of the same line directed downward.

3. Find the coördinates of the points on the line $\begin{cases} x = 3 - \frac{4}{5}\rho \\ y = -2 + \frac{3}{5}\rho \end{cases}$ for which $\rho = 3, -2$, and 4 . Verify the geometric significance of ρ for each of these points by Theorem IV, p. 31.

4. Find the product of the distances from $P_1(2, 1)$ to the intersections of the line $x = 2 - \frac{3}{5}\rho$ and $y = 1 + \frac{4}{5}\rho$ with the circle $x^2 + y^2 = 25$, and explain the sign of the result.
Ans. -20 .

5. Given the ellipse $x^2 + 4y^2 = 16$ and the line $x = x_1 - \frac{4}{5}\rho$ and $y = y_1 + \frac{3}{5}\rho$; find the equation whose roots are the distances from $P_1(x_1, y_1)$ to the points of intersection of the line and ellipse.

$$\text{Ans. } \frac{52}{25}\rho^2 - \frac{8x_1 - 24y_1}{5}\rho + x_1^2 + 4y_1^2 - 16 = 0.$$

6. Find the condition that P_1 in problem 5 should be the middle point of the chord on which it lies.

Hint. The two values of ρ must be numerically equal, with opposite signs.

7. Given the parabola $y^2 = 4x$ and the line $x = 2 + \rho \cos \alpha$, $y = -4 + \rho \cos \beta$; find the condition which $\cos \alpha$ and $\cos \beta$ must satisfy if the line meets the parabola in but one point.

$$\text{Ans. } \cos^2 \alpha + 4 \cos \alpha \cos \beta + 2 \cos^2 \beta = 0.$$

8. If a and b are two numbers such that $a^2 + b^2 = 1$, prove that a and b are the direction cosines of some line.

9. Derive equation (XVI) from Theorem V (p. 95) and Theorem I (p. 28).

10. Prove that the common value of the ratios in (XVI) is the length P_1P .

Hint. Square (XVI), apply the Theorem on the sum of the antecedents and of the consequents, and then take the square root.

11. Derive equations (XV) from (XVI) by means of problem 10.

MISCELLANEOUS PROBLEMS

1. Find the point on the line $3x - 5y + 6 = 0$ which is equidistant from the points $(3, -4)$ and $(2, 1)$.
2. Find the equation of the line through the intersection of the lines $7x + y - 3 = 0$ and $3x + 6y - 11 = 0$ which is perpendicular to the line joining their intersection to the origin.
3. Find the equation of the line through the point $(2, 5)$ such that the portion of the line included between the axes is bisected at that point.
4. Find the equation of the line through the point $(2, -3)$ such that the portion of the line included between the lines $3x + y - 2 = 0$ and $x + 5y + 10 = 0$ is bisected at that point.
5. Prove that the diagonals of a rhombus are perpendicular.
6. If the Y -axis makes an angle of ω with the X -axis, find the equation of the straight line in terms of its intercept b on the Y -axis and its inclination α .
7. If the Y -axis makes an angle of ω with the X -axis, find the equation of the straight line whose inclination is α which passes through $P_1(x_1, y_1)$.
8. If the Y -axis makes an angle of ω' with the X -axis, find the normal form of the equation of the straight line.
9. Find the tangent of the angle which one line makes with another if the axes are oblique.
10. Show that all of the lines for which $m = b$ pass through the same point, and find the coördinates of that point.
11. Show that all of the lines for which $\frac{1}{a} + \frac{1}{b} = \text{constant}$ pass through the same point, and find the coördinates of that point.
12. Prove that all of the lines $Ax + By + C = 0$ for which $A + B + C = 0$ pass through the same point, and find the coördinates of that point.
13. Find the points in which the lines $2x - 3y = 0$, $x + 4y - 2 = 0$, $2x - 3y + \lambda(x + 4y - 2) = 0$, $2x - 3y - \lambda(x + 4y - 2) = 0$ cut the X -axis. Show that the last two points divide the line joining the first two points internally and externally in the same *numerical* ratio.
14. Prove that $Ax + By + C = 0$ represents a straight line by showing that if P_1 and P_2 lie on the locus of the equation, the point which divides P_1P_2 in the ratio λ lies on the locus of the equation.
15. Find the bisectors of the exterior angles of the triangle formed by $2x - 3y + 120 = 0$, $x + y = 0$, and $3x + 4y - 6 = 0$. Show that these lines meet the opposite sides in three points on the same straight line.

16. Find the equation of the line passing through the intersection of $Ax + By + C = 0$ and $A'x + B'y + C' = 0$ which (a) passes through the origin, (b) is parallel to the X -axis, (c) is parallel to the Y -axis.

17. Show that the lines $(A + \lambda A')x + (B + \lambda B')y + (C + \lambda C') = 0$ pass through a point if λ is a variable parameter and the other letters are constant.

18. Let $A_1x + B_1y + C_1 = 0$, $A_2x + B_2y + C_2 = 0$, and $A_3x + B_3y + C_3 = 0$ be three given lines forming a triangle. Show that the equation of any line $Ax + By + C = 0$ may be written in the form

$$\alpha(A_1x + B_1y + C_1) + \beta(A_2x + B_2y + C_2) + \gamma(A_3x + B_3y + C_3) = 0,$$

where α , β , and γ are definite constants.

Hint. Use Theorem III, p. 88.

19. Find the ratio in which the line $2x - 5y + 8 = 0$ divides the line joining the points $P_1(1, 3)$ and $P_2(7, 2)$.

Hint. The coördinates of the point dividing P_1P_2 into segments whose ratio is λ are $\left(\frac{1+7\lambda}{1+\lambda}, \frac{3+2\lambda}{1+\lambda}\right)$; determine λ so that this point lies on the given line.

20. Find the ratio in which the line $x + 3y - 6 = 0$ divides the line joining $(-3, 2)$ and $(6, 1)$.

21. Determine m so that the line $y = mx - 7$ divides the line joining $(3, 2)$ and $(1, 4)$ in the ratio 3:2.

22. Find the equation of the line passing through the point $(2, -3)$ which divides the line joining $(6, 3)$ and $(2, -1)$ in the ratio 2:5.

23. Show that the ratio of the distances from the line $Ax + By + C = 0$ to the points $P_1(x_1, y_1)$ and $P_2(x_2, y_2)$ is $\frac{Ax_1 + By_1 + C}{Ax_2 + By_2 + C}$.

24. Show that the line $Ax + By + C = 0$ divides the line joining $P_1(x_1, y_1)$ and $P_2(x_2, y_2)$ into segments whose ratio is $-\frac{Ax_1 + By_1 + C}{Ax_2 + By_2 + C}$.

25. Show by the preceding example that any line cuts the sides of a triangle P_1P_2 , P_2P_3 , and P_3P_1 in the points L , M , N such that

$$\frac{P_1L}{LP_2} \times \frac{P_2M}{MP_3} \times \frac{P_3N}{NP_1} = -1.$$

26. Plot the line $2x - 3y + 5 = 0$ and indicate all of the points for which $2x - 3y + 5 > 0$.

27. Find the area of the triangle formed by $A_1x + B_1y + C_1 = 0$, $A_2x + B_2y + C_2 = 0$, and $A_3x + B_3y + C_3 = 0$.

CHAPTER V

THE CIRCLE AND THE EQUATION $x^2 + y^2 + Dx + Ey + F = 0$

56. The general equation of the circle. If (α, β) is the center of a circle whose radius is r , then the equation of the circle is (Theorem II, p. 58)

$$(1) \quad x^2 + y^2 - 2\alpha x - 2\beta y + \alpha^2 + \beta^2 - r^2 = 0,$$

or

$$(2) \quad (x - \alpha)^2 + (y - \beta)^2 = r^2.$$

In particular, if the center is the origin, $\alpha = 0$, $\beta = 0$, and (2) reduces to

$$(3) \quad x^2 + y^2 = r^2.$$

Equation (1) is of the form

$$(4) \quad x^2 + y^2 + Dx + Ey + F = 0,$$

where

$$(5) \quad D = -2\alpha, \quad E = -2\beta, \quad \text{and} \quad F = \alpha^2 + \beta^2 - r^2.$$

Can we infer, conversely, that the locus of every equation of the form (4) is a circle? By comparing (4) with (1) we obtain (5). Whence

$$(6) \quad \alpha = -\frac{D}{2}, \quad \beta = -\frac{E}{2}, \quad \text{and} \quad r^2 = \frac{D^2 + E^2 - 4F}{4}.$$

These values of α and β are real, and if $D^2 + E^2 - 4F$ is positive, the value of r is real and the locus of (4) is a circle.

To plot the locus of (4) by points (Rule, p. 60), we solve for y . This gives

$$(7) \quad y = -\frac{E}{2} \pm \sqrt{-x^2 - Dx + \left(\frac{E^2 - 4F}{4}\right)}.$$

The discriminant of the quadratic under the radical in (7) is

$$\Delta = D^2 - 4(-1)\left(\frac{E^2 - 4F}{4}\right) = D^2 + E^2 - 4F,$$

which is the numerator of r^2 in (6).

If Θ is positive, the quadratic under the radical is positive for values of x between the roots (Theorem III, p. 11) and the equation has a locus, as we have seen.

If Θ is zero, the roots of the quadratic are real and equal (Theorem II, p. 3). But for all other values of x the quadratic is negative (Theorem III, p. 11). The locus therefore consists of the single point $\left(-\frac{D}{2}, -\frac{E}{2}\right)$.

For the quadratic in (7) equals zero when $x = -\frac{D}{2}$ (p. 2), and hence, from (7), the corresponding value of y is $-\frac{E}{2}$. This also follows from (6) if we suppose r approaches zero, for then the circle consists only of its center $\left(-\frac{D}{2}, -\frac{E}{2}\right)$.

If Θ is negative, the quadratic in (7) is negative for all values of x (Theorem III, p. 11) except the roots, which are imaginary (Theorem II, p. 3). Hence there is no locus.

The expression $\Theta = D^2 + E^2 - 4F$ is called the **discriminant** of (4). When $\Theta = 0$ the locus of (4) is often called a **point-circle** or a **circle whose radius is zero**.

We have thus proved

Theorem I. *The locus of the equation*

$$(I) \quad x^2 + y^2 + Dx + Ey + F = 0,$$

whose discriminant is $\Theta = D^2 + E^2 - 4F$, is determined as follows:

- (a) When Θ is positive the locus is the circle whose center is $\left(-\frac{D}{2}, -\frac{E}{2}\right)$ and whose radius is $r = \frac{1}{2} \sqrt{D^2 + E^2 - 4F} = \frac{1}{2} \sqrt{\Theta}$.
- (b) When Θ is zero the locus is the point-circle $\left(-\frac{D}{2}, -\frac{E}{2}\right)$.
- (c) When Θ is negative there is no locus.

Corollary. *When $E = 0$ the center of (I) is on the X-axis, and when $D = 0$ the center is on the Y-axis.*

Whenever in what follows it is said that (I) is the equation of a circle it is assumed that Θ is positive.

Ex. 1. Find the locus of the equation $x^2 + y^2 - 4x + 8y - 5 = 0$.

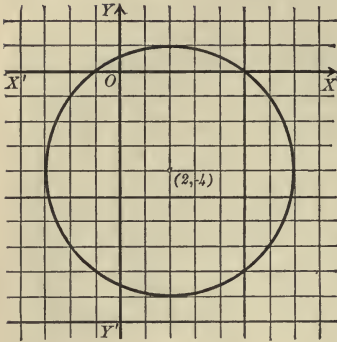

Solution. The given equation is of the form (I), where

$$D = -4, \quad E = 8, \quad F = -5,$$

and hence

$$\Theta = 16 + 64 + 20 = 100 > 0.$$

The locus is therefore a circle whose center is the point $(2, -4)$ and whose radius is $\frac{1}{2}\sqrt{100} = 5$.

The equation $Ax^2 + Bxy + Cy^2 + Dx + Ey + F = 0$ is called the general equation of the second degree in x and y because it contains all

possible terms in x and y of the second and lower degrees.

Theorem II. *The locus of the general equation of the second degree,*

$$(II) \quad Ax^2 + Bxy + Cy^2 + Dx + Ey + F = 0,$$

is a circle when and only when $A = C$, $B = 0$, and $\frac{D^2 + E^2 - 4AF}{A^2}$ is positive.

Proof. The equation of every circle must have the form (I); hence the coefficients of x^2 and y^2 must be equal and the xy term must be lacking; that is, the locus of (II) can be a circle only when $A = C$ and $B = 0$. If these conditions be satisfied, (II) may be written in the form

$$x^2 + y^2 + \frac{D}{A}x + \frac{E}{A}y + \frac{F}{A} = 0,$$

whose locus is a circle when and only when its discriminant $\frac{D^2 + E^2 - 4AF}{A^2}$ is positive. Q.E.D.

57. Circles determined by three conditions. The equation of any circle may be written in either one of the forms

$$(x - \alpha)^2 + (y - \beta)^2 = r^2$$

or

$$x^2 + y^2 + Dx + Ey + F = 0.$$

Each of these equations contains three arbitrary constants. To determine these constants three equations are necessary, and as any equation between the constants means that the circle satisfies some geometrical condition, it follows that a circle may be determined to satisfy three conditions.

Rule to determine the equation of a circle satisfying three conditions.

First step. Let the required equation be

$$(1) \quad (x - \alpha)^2 + (y - \beta)^2 = r^2$$

or

$$(2) \quad x^2 + y^2 + Dx + Ey + F = 0,$$

as may be more convenient.

Second step. Find three equations between the constants $\alpha, \beta,$ and r [or $D, E,$ and F] which express that the circle (1) [or (2)] satisfies the three given conditions.

Third step. Solve the equations found in the second step for $\alpha, \beta,$ and r [or $D, E,$ and F].

Fourth step. Substitute the results of the third step in (1) [or (2)]. The result is the required equation.

Ex. 1. Find the equation of the circle passing through the three points $P_1(0, 1), P_2(0, 6),$ and $P_3(3, 0)$.

Solution. First step. Let the required equation be

$$(3) \quad x^2 + y^2 + Dx + Ey + F = 0.$$

Second step. Since $P_1, P_2,$ and P_3 lie on (3), their coordinates must satisfy (3). Hence we have

$$(4) \quad 1 + E + F = 0,$$

$$(5) \quad 36 + 6E + F = 0,$$

and

$$(6) \quad 9 + 3D + F = 0.$$

Third step. Solving (4), (5), and (6), we obtain

$$E = -7, F = 6, D = -5.$$

Fourth step. Substituting in (3), the required equation is

$$x^2 + y^2 - 5x - 7y + 6 = 0.$$

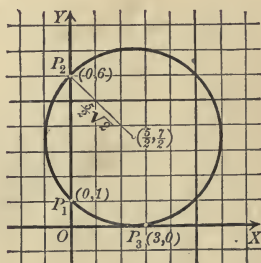

By Theorem I we find that the radius is $\frac{5}{2}\sqrt{2}$ * and the center is the point $(\frac{5}{2}, \frac{7}{2})$.

Ex. 2. Find the equation of the circle passing through the points $P_1(0, -3)$ and $P_2(4, 0)$ which has its center on the line $x + 2y = 0$.

Solution. First step. Let the required equation be

$$(7) \quad x^2 + y^2 + Dx + Ey + F = 0.$$

Second step. Since P_1 and P_2 lie on the locus of (7), we have

$$(8) \quad 9 - 3E + F = 0$$

and

$$(9) \quad 16 + 4D + F = 0.$$

The center of (7) is $(-\frac{D}{2}, -\frac{E}{2})$, and since it lies on the given line,

$$-\frac{D}{2} + 2\left(-\frac{E}{2}\right) = 0,$$

or

$$(10) \quad D + 2E = 0.$$

Third step. Solving (8), (9), and (10), we obtain

$$D = -\frac{14}{5}, E = \frac{7}{5}, \text{ and } F = -\frac{24}{5}.$$

Fourth step. Substituting in (7), we obtain the required equation,

$$x^2 + y^2 - \frac{14}{5}x + \frac{7}{5}y - \frac{24}{5} = 0,$$

or

$$5x^2 + 5y^2 - 14x + 7y - 24 = 0.$$

The center is the point $(\frac{7}{5}, -\frac{7}{10})$, and the radius is $\frac{1}{2}\sqrt{29}$.

PROBLEMS

1. Find the equation of the circle whose center is

(a) $(0, 1)$ and whose radius is 3.

$$\text{Ans. } x^2 + y^2 - 2y - 8 = 0.$$

(b) $(-2, 0)$ and whose radius is 2.

$$\text{Ans. } x^2 + y^2 + 4x = 0.$$

(c) $(-3, 4)$ and whose radius is 5.

$$\text{Ans. } x^2 + y^2 + 6x - 8y = 0.$$

(e) $(\alpha, 0)$ and whose radius is α .

$$\text{Ans. } x^2 + y^2 - 2\alpha x = 0.$$

(f) $(0, \beta)$ and whose radius is β .

$$\text{Ans. } x^2 + y^2 - 2\beta y = 0.$$

(g) $(0, -\beta)$ and whose radius is β .

$$\text{Ans. } x^2 + y^2 + 2\beta y = 0.$$

* The radius is easily obtained, since $\sqrt{2}$ is the length of the diagonal of a square whose side is one unit. We may construct a line whose length is \sqrt{n} by describing a semicircle on a line whose length is $n + 1$ and erecting a perpendicular to the diameter one unit from the end. The length of that perpendicular will be \sqrt{n} .

2. Find the locus of the following equations.

- (a) $x^2 + y^2 - 6x - 16 = 0$. (f) $x^2 + y^2 - 6x + 4y - 5 = 0$.
 (b) $3x^2 + 3y^2 - 10x - 24y = 0$. (g) $(x + 1)^2 + (y - 2)^2 = 0$.
 (c) $x^2 + y^2 = 0$. (h) $7x^2 + 7y^2 - 4x - y = 3$.
 (d) $x^2 + y^2 - 8x - 6y + 25 = 0$. (i) $x^2 + y^2 + 2ax + 2by + a^2 + b^2 = 0$.
 (e) $x^2 + y^2 - 2x + 2y + 5 = 0$. (j) $x^2 + y^2 + 16x + 100 = 0$.

3. Find the equation of the circle which

- (a) has the center (2, 3) and passes through (3, -2).
Ans. $x^2 + y^2 - 4x - 6y - 13 = 0$.
- (b) passes through the points (0, 0), (8, 0), (0, -6).
Ans. $x^2 + y^2 - 8x + 6y = 0$.
- (c) passes through the points (4, 0), (-2, 5), (0, -3).
Ans. $19x^2 + 19y^2 + 2x - 47y - 312 = 0$.
- (d) passes through the points (3, 5) and (-3, 7) and has its center on the X -axis.
Ans. $x^2 + y^2 + 4x - 46 = 0$.
- (e) passes through the points (4, 2) and (-6, -2) and has its center on the Y -axis.
Ans. $x^2 + y^2 + 5y - 30 = 0$.
- (f) passes through the points (5, -3) and (0, 6) and has its center on the line $2x - 3y - 6 = 0$.
Ans. $3x^2 + 3y^2 - 114x - 64y + 276 = 0$.
- (g) has the center (-1, -5) and is tangent to the X -axis.
Ans. $x^2 + y^2 + 2x + 10y + 1 = 0$.
- (h) passes through (1, 0) and (5, 0) and is tangent to the Y -axis.
Ans. $x^2 + y^2 - 6x \pm 2\sqrt{5}y + 5 = 0$.
- (i) passes through (0, 1), (5, 1), (2, -3).
Ans. $2x^2 + 2y^2 - 10x + y - 3 = 0$.
- (j) has the line joining (3, 2) and (-7, 4) as a diameter.
Ans. $x^2 + y^2 + 4x - 6y - 13 = 0$.
- (k) has the line joining (3, -4) and (2, -5) as a diameter.
Ans. $x^2 + y^2 - 5x + 9y + 26 = 0$.
- (l) which circumscribes the triangle formed by $x - 6 = 0$, $x + 2y = 0$, and $x - 2y = 8$.
Ans. $2x^2 + 2y^2 - 21x + 8y + 60 = 0$.
- (m) passes through the points (1, -2), (-2, 4), (3, -6). Interpret the result by the Corollary, p. 98.
- (n) is inscribed in the triangle formed by $4x + 3y - 12 = 0$, $y - 2 = 0$, $x - 10 = 0$.
Ans. $36x^2 + 36y^2 - 516x + 60y + 1585 = 0$.
4. Plot the locus of $x^2 + y^2 - 2x + 4y + k = 0$ for $k = 0, 2, 4, 5 - 2, -4$,
 - 8. What values of k must be excluded?
Ans. $k > 5$.

5. What is the locus of $x^2 + y^2 + Dx + Ey + F = 0$ if D and E are fixed and F varies?

6. For what values of k does the equation $x^2 + y^2 - 4x + 2ky + 10 = 0$ have a locus?
Ans. $k > +\sqrt{6}$ and $k < -\sqrt{6}$.

7. For what values of k does the equation $x^2 + y^2 + kx + F = 0$ have a locus when (a) F is positive; (b) F is zero; (c) F is negative?

Ans. (a) $k > 2\sqrt{F}$ and $k < -2\sqrt{F}$; (b) and (c) all values of k .

8. Find the number of point-circles represented by the equation in problem 7.
Ans. (a) two; (b) one; (c) none.

9. Find the equation of the circle in oblique coördinates if ω is the angle between the axes of coördinates.

Ans. $(x - \alpha)^2 + (y - \beta)^2 + 2(x - \alpha)(y - \beta) \cos \omega = r^2$.

10. Write an equation representing all circles with the radius 5 whose centers lie on the X -axis; on the Y -axis.

11. Find the number of values of k for which the locus of

$$(a) x^2 + y^2 + 4kx - 2y + 5k = 0,$$

$$(b) x^2 + y^2 + 4kx - 2y - k = 0,$$

$$(c) x^2 + y^2 + 4kx - 2y + 4k = 0$$

is a point-circle.

Ans. (a) two; (b) none; (c) one.

12. Plot the circles $x^2 + y^2 + 4x - 9 = 0$, $x^2 + y^2 - 4x - 9 = 0$, and $x^2 + y^2 + 4x - 9 + k(x^2 + y^2 - 4x - 9) = 0$ for $k = \pm 1, \pm 3, \pm \frac{1}{3}, -5, -\frac{1}{5}$. Must any values of k be excluded?

13. Plot the circles $x^2 + y^2 + 4x = 0$, $x^2 + y^2 - 4x = 0$, and $x^2 + y^2 + 4x + k(x^2 + y^2 - 4x) = 0$ for the values of k in problem 12. Must any values of k be excluded?

14. Plot the circles $x^2 + y^2 + 4x + 9 = 0$, $x^2 + y^2 - 4x + 9 = 0$, and $x^2 + y^2 + 4x + 9 + k(x^2 + y^2 - 4x + 9) = 0$ for $k = -3, -\frac{1}{3}, -5, -\frac{1}{5}, -\frac{2}{3}, -\frac{2}{5}, -1$. What values of k must be excluded?

58. Systems of circles. An equation of the form

$$x^2 + y^2 + Dx + Ey + F = 0$$

will define a system of circles if one or more of the coefficients contain an arbitrary constant. Thus the equation

$$x^2 + y^2 - r^2 = 0$$

represents the system of concentric circles whose centers are at the origin. Very interesting systems of circles, and the only systems we shall consider, are represented by equations analogous to (XIII), p. 119.

Theorem III. *Given two circles,*

$$C_1 : x^2 + y^2 + D_1x + E_1y + F_1 = 0$$

and $C_2 : x^2 + y^2 + D_2x + E_2y + F_2 = 0;$

then the locus of the equation

$$(III) \quad x^2 + y^2 + D_1x + E_1y + F_1 \\ + k(x^2 + y^2 + D_2x + E_2y + F_2) = 0$$

is a circle except when $k = -1$. In this case the locus is a straight line.

Proof. Clearing the parenthesis in (III) and collecting like terms in x and y , we obtain

$$(1+k)x^2 + (1+k)y^2 + (D_1 + kD_2)x + (E_1 + kE_2)y + (F_1 + kF_2) = 0.$$

Dividing by $1+k$ we have

$$x^2 + y^2 + \frac{D_1 + kD_2}{1+k}x + \frac{E_1 + kE_2}{1+k}y + \frac{F_1 + kF_2}{1+k} = 0.$$

The locus of this equation is a circle (Theorem I, p. 131). If, however, $k = -1$, we cannot divide by $1+k$. But in this case equation (III) becomes

$$(D_1 - D_2)x + (E_1 - E_2)y + (F_1 - F_2) = 0,$$

which is of the first degree in x and y . Its locus is then a straight line called the **radical axis** of C_1 and C_2 . Q. E. D.

Corollary I. *The center of the circle (III) lies upon the line joining the centers of C_1 and C_2 and divides that line into segments whose ratio is equal to k .*

For by Theorem I (p. 131) the center of C_1 is $P_1\left(-\frac{D_1}{2}, -\frac{E_1}{2}\right)$ and of C_2 is $P_2\left(-\frac{D_2}{2}, -\frac{E_2}{2}\right)$. The point dividing P_1P_2 into segments whose ratio equals k is (Theorem VII, p. 39) the point $\left[\frac{-\frac{D_1}{2} + k\left(-\frac{D_2}{2}\right)}{1+k}, \frac{-\frac{E_1}{2} + k\left(-\frac{E_2}{2}\right)}{1+k}\right]$, or, simplifying, $\left(-\frac{D_1 + kD_2}{2(1+k)}, -\frac{E_1 + kE_2}{2(1+k)}\right)$, which is the center of (III).

Corollary II. *The equation of the radical axis of C_1 and C_2 is*

$$(D_1 - D_2)x + (E_1 - E_2)y + (F_1 - F_2) = 0.$$

Corollary III. *The radical axis of two circles is perpendicular to the line joining their centers.*

Hint. Find the line joining the centers of C_1 and C_2 (Theorem VII, p. 97) and show that it is perpendicular to the radical axis by Corollary III, p. 87.

The system (III) may have three distinct forms, as illustrated in the following examples. These three forms correspond to the relative positions of C_1 and C_2 , which may intersect in two points, be tangent to each other, or not meet at all.

Ex. 1. Plot the system of circles represented by

$$x^2 + y^2 + 8x - 9 + k(x^2 + y^2 - 4x - 9) = 0.$$

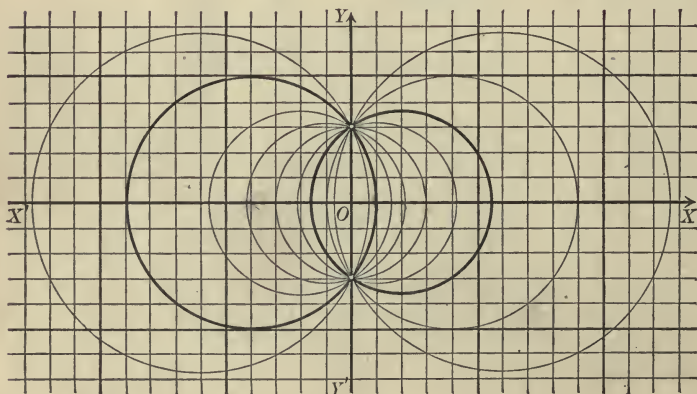

Solution. The figure shows the circles

$$x^2 + y^2 + 8x - 9 = 0 \text{ and } x^2 + y^2 - 4x - 9 = 0$$

plotted in heavy lines and the circles corresponding to

$$k = 2, 5, 1, \frac{1}{2}, -4, -\frac{5}{2}, \text{ and } -\frac{1}{4};$$

these circles all pass through the intersection of the first two.

The radical axis of the two circles plotted in heavy lines, which corresponds to $k = -1$, is the Y -axis.

Ex. 2. Plot the system of circles represented by

$$x^2 + y^2 + 8x + k(x^2 + y^2 - 4x) = 0.$$

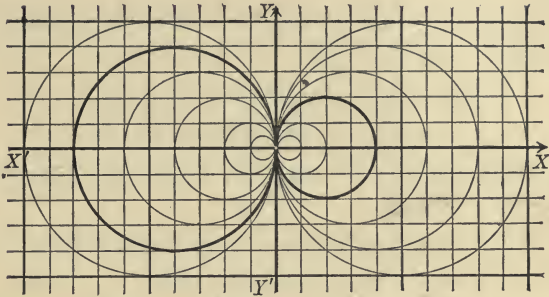

Solution. The figure shows the circles

$$x^2 + y^2 + 8x = 0 \text{ and } x^2 + y^2 - 4x = 0$$

plotted in heavy lines and the circles corresponding to

$$k = 2, 3, \frac{7}{5}, 5, 1, \frac{1}{2}, -7, \frac{1}{5}, -4, -3, \text{ and } -\frac{1}{7}.$$

These circles are all tangent to the given circles at their point of tangency. The locus for $k = 2$ is the origin.

Ex. 3. Plot the system of circles represented by

$$x^2 + y^2 - 10x + 9 + k(x^2 + y^2 + 8x + 9) = 0.$$

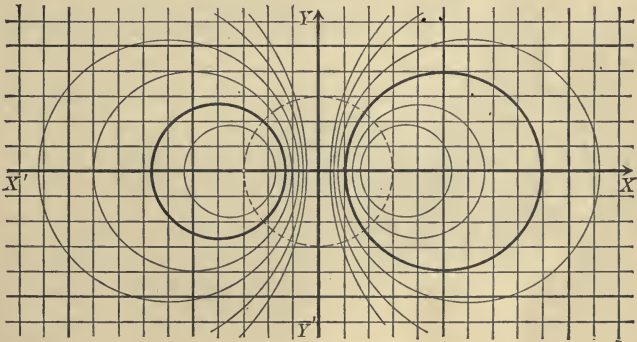

Solution. The figure shows the circles

$$x^2 + y^2 - 10x + 9 = 0 \text{ and } x^2 + y^2 + 8x + 9 = 0$$

plotted in heavy lines and the circles corresponding to

$$k = \frac{1}{5}, 17, \frac{1}{8}, -10, -\frac{1}{10}, \text{ and } -\frac{1}{2}.$$

These circles all cut the dotted circle at right angles, as will be shown later. For $k = \frac{2}{7}$ the locus is the point-circle (3, 0), and for $k = 8$ it is the point-circle (-3, 0).

In all three examples the radical axis, for which $k = -1$, is the Y -axis.

Theorem IV. *When the circles*

$$C_1 : x^2 + y^2 + D_1x + E_1y + F_1 = 0$$

and

$$C_2 : x^2 + y^2 + D_2x + E_2y + F_2 = 0$$

intersect in two points $P_1(x_1, y_1)$ and $P_2(x_2, y_2)$, then the system of circles represented by

$x^2 + y^2 + D_1x + E_1y + F_1 + k(x^2 + y^2 + D_2x + E_2y + F_2) = 0$
consists of all circles passing through P_1 and P_2 .

Proof. First, every circle of the system passes through P_1 and P_2 . For, since P_1 lies on C_1 and C_2 , we have

$$x_1^2 + y_1^2 + D_1x_1 + E_1y_1 + F_1 = 0$$

and

$$x_1^2 + y_1^2 + D_2x_1 + E_2y_1 + F_2 = 0.$$

Multiply the second equation by k and add to the first; this gives

$$x_1^2 + y_1^2 + D_1x_1 + E_1y_1 + F_1 + k(x_1^2 + y_1^2 + D_2x_1 + E_2y_1 + F_2) = 0,$$

which is the condition that P_1 lies on any circle of the system. In the same manner we can show that every circle of the system passes through P_2 .

In the second place, every circle which passes through P_1 and P_2 is in the system. For any such circle is determined by P_1, P_2 and a point $P_3(x_3, y_3)$ not on the line P_1P_2 . Then if P_3 lies on a circle of the system, we have

$$x_3^2 + y_3^2 + D_1x_3 + E_1y_3 + F_1 + k(x_3^2 + y_3^2 + D_2x_3 + E_2y_3 + F_2) = 0,$$

and hence
$$k = -\frac{x_3^2 + y_3^2 + D_1x_3 + E_1y_3 + F_1}{x_3^2 + y_3^2 + D_2x_3 + E_2y_3 + F_2}.$$

That is, a value of k can be determined so that the corresponding circle passes through P_3 . Since P_3 is any point not on P_1P_2 , that circle is any circle which passes through P_1 and P_2 ; and hence every circle which passes through P_1 and P_2 belongs to the system.

Corollary. *The radical axis of two intersecting circles is their common chord.*

In like manner we may prove

Theorem V. *When the circles*

$$C_1: x^2 + y^2 + D_1x + E_1y + F_1 = 0$$

and
$$C_2: x^2 + y^2 + D_2x + E_2y + F_2 = 0$$

are tangent at the point $P_1(x_1, y_1)$, then the system of circles represented by

$$x^2 + y^2 + D_1x + E_1y + F_1 + k(x^2 + y^2 + D_2x + E_2y + F_2) = 0$$

consists of all circles tangent to C_1 and C_2 at P_1 .

These theorems show how to construct the circles of the system in case C_1 and C_2 intersect or are tangent, but there is no analogous theorem if C_1 and C_2 do not intersect. In what follows we shall consider a method which applies to all three cases.

Theorem VI. *The equation of the system (III), (p. 137), may be written in the form*

$$(VI) \quad x^2 + y^2 + k'x + F = 0,$$

where k' is an arbitrary constant, if the axes of x and y be respectively chosen as the line of centers and the radical axis of C_1 and C_2 .

Proof. No matter how the axes be chosen, the equations of C_1 and C_2 have the forms

$$C_1: x^2 + y^2 + D_1x + E_1y + F_1 = 0$$

and
$$C_2: x^2 + y^2 + D_2x + E_2y + F_2 = 0.$$

If the centers of C_1 and C_2 lie on the X -axis, then $E_1 = 0$ and $E_2 = 0$ (Corollary, p. 131). The equation of the radical axis (Corollary II, p. 138) then becomes

$$(D_1 - D_2)x + (F_1 - F_2) = 0.$$

If this line is the Y -axis, whose equation is $x = 0$, we must have $F_1 - F_2 = 0$, and hence $F_1 = F_2$. Substituting F for F_1 and F_2 and setting $E_1 = 0$ and $E_2 = 0$ in (III), we obtain

$$x^2 + y^2 + D_1x + F + k(x^2 + y^2 + D_2x + F) = 0.$$

Collecting like powers of x and y and dividing by $1 + k$, we obtain

$$x^2 + y^2 + \frac{D_1 + kD_2}{1 + k}x + F = 0.$$

The coefficient of x changes with k and may be denoted by a single letter; if we set

$$\frac{D_1 + kD_2}{1 + k} = k',$$

we obtain equation (VI).

Q. E. D.

Corollary. *The centers of the circles of the system (VI) lie on the X-axis.*

The study of the system of circles (III), p. 137, may then be effected by the study of the system (VI), whose equation is in a simpler form than that of (III).

Theorem VII. *If r' is the radius of that circle of the system*

$$x^2 + y^2 + k'x + F = 0$$

whose center is $(\alpha', 0)$, then

$$r'^2 = \alpha'^2 - F.$$

Proof. For by Theorem I (p. 131) we have $r'^2 = \frac{k'^2 - 4F}{4}$ and $\alpha'^2 = \frac{k'^2}{4}$. Hence $r'^2 = \alpha'^2 - F$.

Corollary I. *When F is negative, r' is the hypotenuse of a right triangle whose legs are α' and $\sqrt{-F}$.**

Corollary II. *When F is zero, then $r' = \alpha'$.*

Corollary III. *When F is positive, α' is the hypotenuse of a right triangle whose legs are r' and \sqrt{F} .*

We may readily construct circles of the system (VI) by the use of these corollaries. With the preliminary remark that the centers of all of the circles of the system lie on the X-axis (by the Corollary), we shall consider the three cases separately.

* When F is negative, $-F$ is positive, and hence $\sqrt{-F}$ is a real number.

CASE I. $F < 0$. In this case $r'^2 = \alpha'^2 - F$ is positive for all real values of α' , and hence every point on the X -axis may be used as the center of a circle belonging to the system.

On OY lay off $OA = \sqrt{-F}$. With any point P' on the X -axis as center and with $P'A$ as a radius, describe a circle; this circle will belong to the system. For let $OP' = \alpha'$; then $P'A = r'$ by Corollary I. The system is then composed of all circles whose centers lie on the X -axis which pass through $A(0, +\sqrt{-F})$. It is evident that the circles will also pass through $B(0, -\sqrt{-F})$.

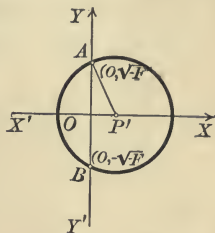

CASE II. $F = 0$. In this case $r'^2 = \alpha'^2$, and hence all points on the X -axis may be used as centers. Further, the circles of the system will all pass through the origin (Theorem VI, p. 73). Hence the circle whose center is any point P' on the X -axis and whose radius is $P'O$ will belong to the system. It is evident that all of the circles of the system are tangent to the Y -axis at the origin and also to each other.

CASE III. $F > 0$. In this case $r'^2 = \alpha'^2 - F$ is positive only when α' is numerically greater than \sqrt{F} , and hence points on the X -axis for which α' is numerically less than \sqrt{F} cannot be used as centers.

With O as a center and with \sqrt{F} as a radius, describe a circle, the dotted circle in the figure. Let P' be any point on the X -axis outside of this circle. Draw $P'A$ tangent to the dotted circle. With P' as center and $P'A$ as radius, describe a circle; this circle will belong to the system. For let $P'O = \alpha'$; then, since $OA = \sqrt{F}$, and since A is a right angle, $P'A = r'$ by Corollary III. Two intersecting circles whose tangents at a point of intersection are perpendicular are said to be **orthogonal**; hence the system is composed of all circles whose centers are on the X -axis which cut the dotted circle

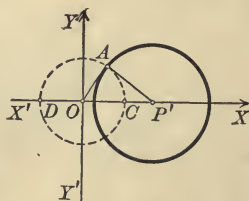

orthogonally. If P' falls at C or D , the radius will be zero; that is, the point-circles C and D belong to the system and are called its **limiting points**. Hence

Theorem VIII. *The circles of the system represented by*

$$x^2 + y^2 + k'x + F = 0$$

have their centers on the X-axis, and

(a) *pass through $(0, +\sqrt{-F})$ and $(0, -\sqrt{-F})$ if F is negative;*

(b) *are tangent to each other at the origin if $F = 0$;*

(c) *are orthogonal to the circle $x^2 + y^2 = F$ if F is positive.*

The constructions given in the proof were used in drawing the figures on pages 138 and 139.

It is evident from the figures, and can be proved analytically, that there are no point-circles if F is negative, that there is one point-circle if F is zero, and that there are two if F is positive.

59. The length of the tangent.

Theorem IX. *Given a point $P_1(x_1, y_1)$ and the circle*

$$C : x^2 + y^2 + Dx + Ey + F = 0,$$

then the product of any secant through P_1 and its external segment is

$$(IX) \quad x_1^2 + y_1^2 + Dx_1 + Ey_1 + F.$$

Proof. Let the equations of any line through P_1 be (Theorem XV, p. 124)

$$x = x_1 + \rho \cos \alpha,$$

$$y = y_1 + \rho \cos \beta.$$

Then if the point (x, y) or $(x_1 + \rho \cos \alpha, y_1 + \rho \cos \beta)$ lies on C , we have (Corollary, p. 53)

$$(x_1 + \rho \cos \alpha)^2 + (y_1 + \rho \cos \beta)^2 + D(x_1 + \rho \cos \alpha) + E(y_1 + \rho \cos \beta) + F = 0.$$

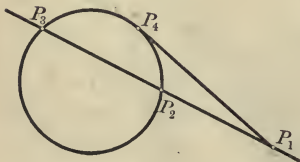

Simplifying, arranging according to powers of ρ , and using (1), p. 123, we have

$$\rho^2 + \rho[(2x_1 + D)\cos\alpha + (2y_1 + E)\cos\beta] + x_1^2 + y_1^2 + Dx_1 + Ey_1 + F_1 = 0.$$

The roots of this quadratic are the lengths of the secant P_1P_3 and its external segment P_1P_2 . Hence the product of P_1P_3 and P_1P_2 is (Theorem I, p. 3)

$$x_1^2 + y_1^2 + Dx_1 + Ey_1 + F.$$

As this expression does not contain $\cos\alpha$ or $\cos\beta$ it is immaterial in what direction the secant be drawn. Q.E.D.

Corollary. *The square of the length of the tangent from P_1 to C is given by (IX).*

For when the secant swings around on P_1 until it becomes tangent to C , P_1P_3 and P_1P_2 both become equal to P_1P_4 .

Theorem X. *The ratio of the squares of the lengths of the tangents drawn from any point of the circle*

$$C_k : x^2 + y^2 + D_1x + E_1y + F_1 + k(x^2 + y^2 + D_2x + E_2y + F_2) = 0$$

to the circles

$$C_1 : x^2 + y^2 + D_1x + E_1y + F_1 = 0$$

and

$$C_2 : x^2 + y^2 + D_2x + E_2y + F_2 = 0$$

is constant and is equal to $-k$.

Proof. Let $P_1(x_1, y_1)$ be any point on C_k . Then $x_1^2 + y_1^2 + D_1x_1 + E_1y_1 + F_1 + k(x_1^2 + y_1^2 + D_2x_1 + E_2y_1 + F_2) = 0$.

Dividing by the parenthesis and transposing, we obtain

$$\frac{x_1^2 + y_1^2 + D_1x_1 + E_1y_1 + F_1}{x_1^2 + y_1^2 + D_2x_1 + E_2y_1 + F_2} = -k.$$

By the Corollary the numerator of this fraction is the square of the length of the tangent from P_1 to C_1 , and the denominator is the square of the length of the tangent from P_1 to C_2 . Hence the ratio of the squares of the lengths of those tangents is constant and equal to $-k$. Q.E.D.

Corollary I. *The locus of a point from which the ratio of the squares of the lengths of the tangents to the circles C_1 and C_2 is constant and equal to $-k$ is the circle C_k .*

Theorem X proves only one part of the Corollary. It remains to be proved that all points such that the ratio of the squares of the lengths of the tangents from these points to C_1 and C_2 equals $-k$ lie on C_k .

Corollary II. *The locus of points from which tangents to two circles are equal is the radical axis of those circles.*

PROBLEMS

1. By means of Theorem VIII plot the following systems of circles.

(a) $x^2 + y^2 + 4x - 1 + k(x^2 + y^2 - 2x - 1) = 0$.

(b) $x^2 + y^2 + 4x + 1 + k(x^2 + y^2 - 2x + 1) = 0$.

(c) $x^2 + y^2 + 4x + k(x^2 + y^2 - 2x) = 0$.

(d) $x^2 + y^2 + 2x - 4 + k(x^2 + y^2 + 6x - 4) = 0$.

(e) $x^2 + y^2 + 2x + 9 + k(x^2 + y^2 - 4x + 9) = 0$.

(f) $x^2 + y^2 - 6x + k(x^2 + y^2 + 8x) = 0$.

2. Find the lengths of the tangents from the point

(a) $(5, 2)$ to the circle $x^2 + y^2 - 4 = 0$.

Ans. 5.

(b) $(-1, 2)$ to the circle $x^2 + y^2 - 6x - 2y = 0$.

Ans. $\sqrt{7}$.

(c) $(2, 5)$ to the circle $2x^2 + 2y^2 + 2x + 4y - 1 = 0$.

Ans. $\frac{3}{2}\sqrt{2}$.

(d) $(1, 2)$ to the circle $x^2 + y^2 = 25$.

Ans. $\sqrt{-20}$.

What does the imaginary answer in (d) mean? Ans. Point is within the circle.

3. Determine the nature of the following systems.

(a) $x^2 + y^2 + 2x - 4y + k(x^2 + y^2 - 2x + 4y) = 0$.

(b) $x^2 + y^2 + 4x - y + k(x^2 + y^2 - 4x + y - 4) = 0$.

(c) $x^2 + y^2 + 2x - 4y + 1 + k(x^2 + y^2 - 2x + 4y + 1) = 0$.

4. Find the equation of the circle passing through the intersections of the circles $x^2 + y^2 - 1 = 0$ and $x^2 + y^2 + 2x = 0$ which passes through the point $(3, 2)$.

Ans. $7x^2 + 7y^2 - 24x - 19 = 0$.

5. Find the equation of the circle passing through the intersections of $x^2 + y^2 - 6x = 0$ and $x^2 + y^2 - 4 = 0$ which passes through $(2, -2)$.

Ans. $x^2 + y^2 - 3x - 2 = 0$.

6. Find the equation of that circle of the system $x^2 + y^2 - 4x - 3 + k(x^2 + y^2 - 4y - 3) = 0$ whose center lies on the line $x - y - 4 = 0$.

Ans. $x^2 + y^2 - 6x + 2y - 3 = 0$.

7. Find the equation of the circle passing through the intersections of $x^2 + y^2 - 4x + 2y = 0$ and $x^2 + y^2 - 2y - 4 = 0$ whose center lies on the line $2x + 4y - 1 = 0$.
Ans. $x^2 + y^2 - 3x + y - 1 = 0$.

8. Find the equations of the circles passing through the intersections of $x^2 + y^2 - 4 = 0$ and $x^2 + y^2 + 2x - 3 = 0$ whose radii equal 4.
Ans. $x^2 + y^2 - 6x - 7 = 0$ and $x^2 + y^2 + 8x = 0$.

9. Find the radical axes of the circles $x^2 + y^2 - 4x = 0$, $x^2 + y^2 + 6x - 8y = 0$, and $x^2 + y^2 + 6x - 8 = 0$ taken by pairs, and show that they meet in a point.

10. Find the radical axes of the circles $x^2 + y^2 - 9 = 0$, $3x^2 + 3y^2 - 6x + 8y - 1 = 0$, and $x^2 + y^2 + 8y = 0$ taken by pairs, and show that they meet in a point.

11. Show that the radical axes of any three circles taken by pairs meet in a point.

12. By means of problem 11 show that a circle may be drawn cutting any three circles at right angles.

13. By means of problem 11 prove that if several circles pass through two fixed points their chords of intersection with a fixed circle will pass through a fixed point.

14. The square of the tangent from any point P_1 of one circle to another is proportional to the distance from the radical axis of the two circles to P_1 .

15. If C_1 and C_2 (Theorem III) are concentric, then all the circles of the system (III) are concentric.

16. Show that when C_1 and C_2 (Theorem III) are concentric the equation of the system (III) cannot be written in the form given in Theorem VI.

17. Show that the radical axis of any pair of circles in the system (III) is the same as the radical axis of C_1 and C_2 .

18. How may problem 11 be stated if the three circles are point-circles?

MISCELLANEOUS PROBLEMS

1. Find the equation of the circle which circumscribes the triangle formed by $x + 2y = 0$, $3x - 2y = 6$, and $x - y = 5$.

2. Find the equation of the circle inscribed in the triangle in problem 1.

3. Find the angle between the radii of the circles $x^2 + y^2 = 25$ and $x^2 + y^2 - 16x + 39 = 0$ which are drawn to a point of intersection.

Hint. Find the radii, the length of the line of centers, and apply 17, p. 20.

4. Find the angle between the radii of the circles $x^2 + y^2 + D_1x + E_1y + F_1 = 0$ and $x^2 + y^2 + D_2x + E_2y + F_2 = 0$ which are drawn to a point of intersection.

5. Find the condition that the angle in problem 4 should be a right angle.
6. Show that an angle inscribed in a semicircle is a right angle.
7. Prove that the perpendicular dropped from a point on a circle to a diameter is a mean proportional between the segments of the diameter.
8. If ω is the angle between the oblique axes OX and OY , then the locus of $x^2 + 2 \cos \omega xy + y^2 + Dx + Ey + F = 0$ is a circle.
9. Given a circle $C: x^2 + y^2 + Dx + Ey + F = 0$ and a line $L: Ax + By + C = 0$; show that the system of curves $x^2 + y^2 + Dx + Ey + F + k(Ax + By + C) = 0$ consists of all circles whose centers lie on the line through the center of C perpendicular to L .
10. Find the radical axis of any two circles of the system in problem 9.
11. Find a geometric interpretation of k in the equation in problem 9.
12. What does the equation of the system in problem 9 become if
 (a) the Y -axis is the line L and the X -axis passes through the center of C ?
 (b) the origin is the center of C and the Y -axis is chosen parallel to L ?
13. Show how to construct the circles of the system $x^2 + y^2 - r^2 + k(x - a) = 0$ when (a) $r < a$; (b) $r = a$; and (c) $r > a$.

14. Show that the discriminant of (III) is

$$\frac{r_2^2 k^2 - (d^2 - r_1^2 - r_2^2)k + r_1^2}{(1 + k)^2},$$

where r_1 is the radius of C_1 , r_2 of C_2 , and d is the length of the line joining the centers of C_1 and C_2 .

15. From problem 14 show that if there are no point-circles in (III), then C_1 and C_2 intersect; if there is one point-circle in (III), then C_1 and C_2 are tangent; if there are two point-circles in (III), C_1 and C_2 do not intersect.

CHAPTER VI

POLAR COÖRDINATES

60. Polar coördinates. In this chapter we shall consider a second method of determining points of the plane by pairs of real numbers. We suppose given a fixed point O , called the **pole**, and a fixed line OA , passing through O , called the **polar axis**. Then any point P determines a length $OP = \rho$ and an angle $AOP = \theta$. The numbers ρ and θ are called the **polar coördinates** of P . ρ is called the **radius vector** and θ the **vectorial angle**. The vectorial angle θ is *positive* or *negative* as in Trigonometry (p. 18). The radius vector is *positive* if P lies on the terminal line of θ , and *negative* if P lies on that line produced through the pole O .

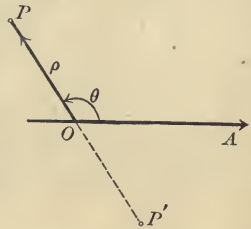

Thus in the figure the radius vector of P is positive, and that of P' is negative.

It is evident that every pair of real numbers (ρ, θ) determines a single point, which may be plotted by the

Rule for plotting a point whose polar coördinates (ρ, θ) are given.

First step. Construct the terminal line of the vectorial angle θ , as in Trigonometry.

Second step. If the radius vector is positive, lay off a

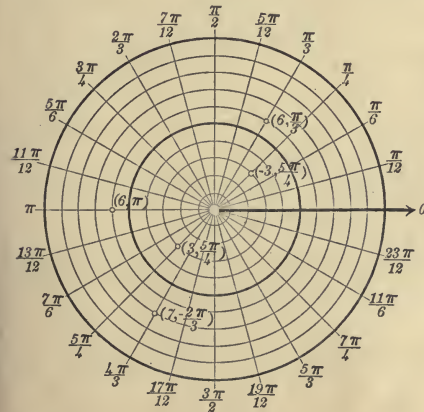

length $OP = \rho$ on the terminal line of θ ; if negative, produce the

terminal line through the pole and lay off OP equal to the numerical value of ρ . Then P is the required point.

In the figure on p. 149 are plotted the points whose polar coordinates are $(6, \frac{\pi}{3})$, $(3, \frac{5\pi}{4})$, $(-3, \frac{5\pi}{4})$, $(6, \pi)$, and $(7, -\frac{2\pi}{3})$.

Every point P determines an infinite number of pairs of numbers (ρ, θ) .

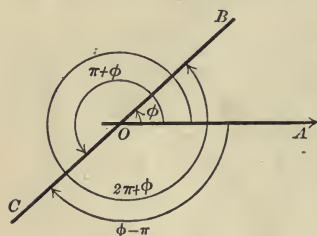

The values of θ will differ by some multiple of π , so that if ϕ is one value of θ the others will be of the form $\phi + k\pi$, where k is a positive or negative integer. The values of ρ will be the same numerically, but will be positive or negative, if P lies on OB , according as the value of θ is chosen so that OB or OC is the terminal line. Thus, if $OB = \rho$ the coordinates of B may be written in any one of the forms (ρ, ϕ) , $(-\rho, \pi + \phi)$, $(\rho, 2\pi + \phi)$, $(-\rho, \phi - \pi)$, etc.

Unless the contrary is stated, we shall always suppose that θ is positive, or zero, and less than 2π ; that is, $0 \leq \theta < 2\pi$.

PROBLEMS

1. Plot the points $(4, \frac{\pi}{4})$, $(6, \frac{2\pi}{3})$, $(-2, \frac{2\pi}{3})$, $(4, \frac{\pi}{3})$, $(-4, \frac{4\pi}{3})$, $(5, \pi)$.

2. Plot the points $(6, \pm \frac{\pi}{4})$, $(-2, \pm \frac{\pi}{2})$, $(3, \pi)$, $(-4, \pi)$, $(6, 0)$, $(-6, 0)$.

3. Show that the points (ρ, θ) and $(\rho, -\theta)$ are symmetrical with respect to the polar axis.

4. Show that the points (ρ, θ) , $(-\rho, \theta)$ are symmetrical with respect to the pole.

5. Show that the points $(-\rho, \pi - \theta)$ and (ρ, θ) are symmetrical with respect to the polar axis.

61. Locus of an equation. If we are given an equation in the variables ρ and θ , then the locus of the equation (p. 59) is a curve such that:

1. Every point whose coordinates (ρ, θ) satisfy the equation lies on the curve.

2. The coordinates of every point on the curve satisfy the equation.

The curve may be plotted by solving the equation for ρ and finding the values of ρ for particular values of θ until the coördinates of enough points are obtained to determine the form of the curve.

The plotting is facilitated by the use of polar coördinate paper, which enables us to plot values of θ by lines drawn through the pole and values of ρ by circles having the pole as center. The tables on p. 21 are to be used in constructing tables of values of ρ and θ .

In *discussing* the locus of an equation the following points should be noticed.

1. The *intercepts on the polar axis* are obtained by setting $\theta = 0$ and $\theta = \pi$ and solving for ρ .

But other values of θ may make $\rho = 0$ and hence give a point on the polar axis, namely, the pole.

2. The *curve is symmetrical with respect to the pole* if, when $-\rho$ is substituted for ρ , only the form of the equation is changed.

3. The *curve is symmetrical with respect to the polar axis* if, when $-\theta$ is substituted for θ , only the form of the equation is changed.

4. The *directions from the pole in which the curve recedes to infinity*, if any, are found by obtaining those values of θ for which ρ becomes infinite.

5. The method of finding the *values of θ which must be excluded*, if any, depends on the given equation.

Ex. 1. Discuss and plot the locus of the equation $\rho = 10 \cos \theta$.

Solution. The discussion enables us to simplify the plotting and is therefore put first.

1. For $\theta = 0$ $\rho = 10$, and for $\theta = \pi$ $\rho = -10$. Hence the curve crosses the polar axis 10 units to the right of the pole.

2. The curve is symmetrical with respect to the polar axis, for $\cos(-\theta) = \cos \theta$ (4, p. 19).

θ	ρ	θ	ρ
0	10	$\frac{\pi}{2}$	0
$\frac{\pi}{12}$	9.7	$\frac{7\pi}{12}$	- 2.6
$\frac{\pi}{6}$	8.7	$\frac{2\pi}{3}$	- 5
$\frac{\pi}{4}$	7	$\frac{3\pi}{4}$	- 7
$\frac{\pi}{3}$	5	$\frac{5\pi}{6}$	- 8.7
$\frac{5\pi}{12}$	2.6	$\frac{11\pi}{12}$	- 9.7
		π	-10

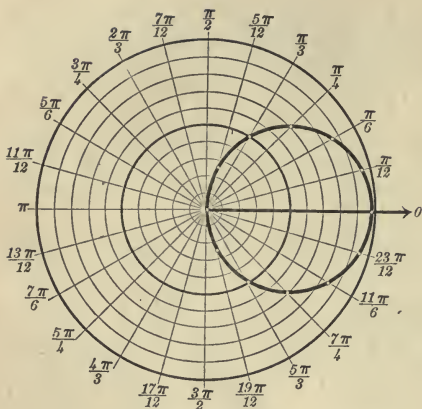

no new points are obtained. The locus is a circle.

Ex. 2. Discuss and plot the locus of the equation $\rho^2 = a^2 \cos 2\theta$.

Solution. The discussion gives us the following properties.

1. For $\theta = 0$ or π $\rho = \pm a$. Hence the curve crosses the polar axis a units to the right and left of the pole.

2. The curve is symmetrical with respect to the pole.

3. It is also symmetrical with respect to the polar axis, for $\cos(-2\theta) = \cos 2\theta$ (4, p. 19).

4. ρ does not become infinite.

5. ρ is imaginary when $\cos 2\theta$ is negative. $\cos 2\theta$ is negative when 2θ is in

θ	ρ	θ	ρ
0	$\pm a$	$\frac{\pi}{6}$	$\pm .7a$
$\frac{\pi}{12}$	$\pm .93a$	$\frac{\pi}{4}$	0

the second or third quadrant; that is, when

$$\frac{3\pi}{2} > 2\theta > \frac{\pi}{2} \text{ or } \frac{7\pi}{2} > 2\theta > \frac{5\pi}{2}.$$

Hence we must exclude values of θ such that

$$\frac{3\pi}{4} > \theta > \frac{\pi}{4} \text{ and } \frac{7\pi}{4} > \theta > \frac{5\pi}{4}.$$

The accompanying table of values is all that need be computed when we take account of 2, 3, and 5.

3. As $\cos \theta$ is never infinite, the curve does not recede to infinity. Hence the curve is a closed curve.

4. No values of θ make ρ imaginary.

Computing a table of values we obtain the table on p. 151.

As the curve is symmetrical with respect to the polar axis, the rest of the curve may be easily constructed without computing the table farther; but as the curve we have already constructed is symmetrical with respect to the polar axis,

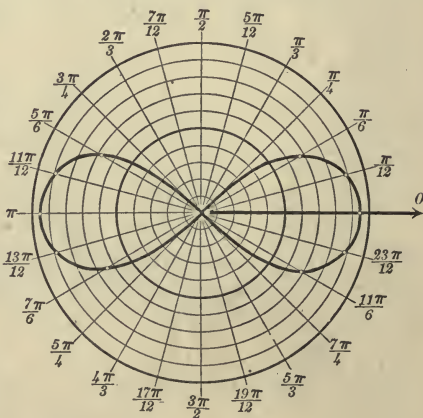

The complete curve is obtained by plotting these points and the points symmetrical to them with respect to the polar axis. The curve is called a lemniscate. In the figure a is taken equal to 9.5.

Ex. 3. Discuss and plot the locus of the equation

$$\rho = \frac{2}{1 + \cos \theta}.$$

Solution. 1. For $\theta = 0$ $\rho = 1$, and for $\theta = \pi$ $\rho = \infty$; so the curve crosses the polar axis one unit to the right of the pole.

2. The curve is not symmetrical with respect to the pole. How may this be inferred from 1?

3. The curve is symmetrical with respect to the polar axis, since $\cos(-\theta) = \cos \theta$ (4, p. 19).

4. ρ becomes infinite when $1 + \cos \theta = 0$ or $\cos \theta = -1$ and hence $\theta = \pi$. The curve recedes to infinity in but one direction.

5. ρ is never imaginary.

On account of 3 the table of values is computed only to $\theta = \pi$, and the rest of the curve is obtained from the symmetry with respect to the polar axis. The locus is a parabola.

θ	ρ	θ	ρ
0	1	$\frac{7\pi}{12}$	2.7
$\frac{\pi}{12}$	1.02	$\frac{2\pi}{3}$	4
$\frac{\pi}{6}$	1.07	$\frac{3\pi}{4}$	6.7
$\frac{\pi}{4}$	1.2	$\frac{5\pi}{6}$	14
$\frac{\pi}{3}$	1.3	$\frac{11\pi}{12}$	50
$\frac{5\pi}{12}$	1.6	π	∞
$\frac{\pi}{2}$	2		

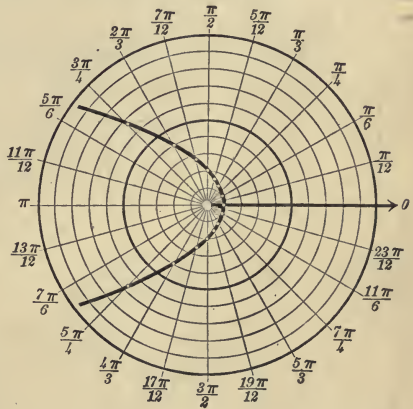

PROBLEMS

Discuss and plot the loci of the following equations.

1. $\rho = 10$. $\theta = \tan^{-1}1$.

5. $\rho \sin \theta = 4$.

2. $\rho = 5$. $\theta = \frac{5\pi}{6}$.

6. $\rho = \frac{4}{1 - \cos \theta}$.

3. $\rho = 16 \cos \theta$.

7. $\rho = \frac{8}{2 - \cos \theta}$.

4. $\rho \cos \theta = 6$.

8. $\rho = \frac{8}{1 - 2 \cos \theta}$.

9. $\rho = a \sin \theta$.

10. $\rho = a(1 - \cos \theta)$.

11. $\rho^2 \sin 2\theta = 16$.

12. $\rho^2 = 16 \sin 2\theta$.

13. $\rho^2 \cos^2 2\theta = a^2$.

14. $\rho = a \sin 2\theta$. $\rho = a \cos 2\theta$.

15. $\rho = \frac{8}{1 - e \cos \theta}$
for $e = 1, 2, \frac{1}{2}$.

16. $\rho \cos \theta = a \sin^2 \theta$.

17. $\rho \cos \theta = a \cos 2\theta$.

18. $\rho = a(4 + b \cos \theta)$
for $b = 3, 4, 6$.

19. $\rho = \frac{10}{1 + \tan \theta}$.

20. $\rho = a \sec \theta \pm b$
for $a > b, a = b, a < b$.

21. $\rho = a\theta$.

22. $\rho = a \sin 3\theta$. $\rho = a \cos 3\theta$.

23. Prove that the locus of an equation is symmetrical with respect to $\theta = \frac{\pi}{2}$ if the results of substituting $\frac{\pi}{2} + \theta$ and $\frac{\pi}{2} - \theta$ give equations which differ only in form.

24. Apply the test for symmetry in problem 23 to the loci of 4, 5, 10, 11, and 12.

62. Transformation from rectangular to polar coördinates.

Let OX and OY be the axes of a rectangular system of coördinates, and let O be

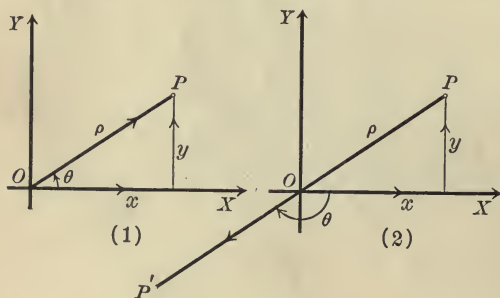

the pole and OX the polar axis of a system of polar coördinates. Let (x, y) and (ρ, θ) be respectively the rectangular and polar coördinates of any point P . It is necessary

to distinguish two cases according as ρ is positive or negative.

When ρ is *positive* (Fig. 1) we have, by definition,

$$\cos \theta = \frac{x}{\rho}, \quad \sin \theta = \frac{y}{\rho},$$

whatever quadrant P is in.

Hence

$$(1) \quad x = \rho \cos \theta, \quad y = \rho \sin \theta.$$

When ρ is *negative* (Fig. 2) we consider the point P' symmetrical to P with respect to O , whose rectangular and polar coördinates are respectively $(-x, -y)$ and $(-\rho, \theta)$. The radius vector of P' , $-\rho$, is positive since ρ is negative, and we can therefore use equations (1). Hence for P'

$$-x = -\rho \cos \theta, \quad -y = -\rho \sin \theta;$$

and hence for P

$$x = \rho \cos \theta, \quad y = \rho \sin \theta,$$

as before.

Hence we have

Theorem I. *If the pole coincides with the origin and the polar axis with the positive X-axis, then*

$$(I) \quad \begin{cases} x = \rho \cos \theta, \\ y = \rho \sin \theta, \end{cases}$$

where (x, y) are the rectangular coördinates and (ρ, θ) the polar coördinates of any point.

Equations I are called the **equations of transformation** from rectangular to polar coördinates. They express the rectangular coördinates of any point in terms of the polar coördinates of that point and enable us to find the equation of a curve in polar coördinates when its equation in rectangular coördinates is known, and *vice versa*.

From the figures we also have

$$(2) \quad \begin{cases} \rho^2 = x^2 + y^2, & \theta = \tan^{-1} \frac{y}{x}, \\ \sin \theta = \frac{y}{\pm \sqrt{x^2 + y^2}}, & \cos \theta = \frac{x}{\pm \sqrt{x^2 + y^2}}. \end{cases}$$

These equations express the polar coördinates of any point in terms of the rectangular coördinates. They are not as convenient for use as (I), although the first one is at times very convenient.

Ex. 1. Find the equation of the circle $x^2 + y^2 = 25$ in polar coördinates.

Solution. Substitute the values of x and y given by (I). This gives $\rho^2 \cos^2 \theta + \rho^2 \sin^2 \theta = 25$, or (by 3, p. 19) $\rho^2 = 25$; and hence $\rho = \pm 5$, which is the required equation. It expresses the fact that the point (ρ, θ) is five units from the origin.

Ex. 2. Find the equation of the lemniscate (Ex. 2, p. 152) $\rho^2 = a^2 \cos 2\theta$ in rectangular coördinates.

Solution. By 14, p. 20, we have

$$\rho^2 = a^2 (\cos^2 \theta - \sin^2 \theta).$$

Multiplying by ρ^2 , $\rho^4 = a^2 (\rho^2 \cos^2 \theta - \rho^2 \sin^2 \theta).$

From (2) and (1), $(x^2 + y^2)^2 = a^2 (x^2 - y^2).$ *Ans.*

63. Applications.

Theorem II. *The general equation of the straight line in polar coördinates is*

$$(II) \quad \rho(A \cos \theta + B \sin \theta) + C = 0,$$

where $A, B,$ and C are arbitrary constants.

Proof. The general equation of the line in rectangular coördinates is (Theorem II, p. 86)

$$Ax + By + C = 0.$$

By substitution from (I) we obtain (II).

Q. E. D.

When $A = 0$ the line is parallel to the polar axis, when $B = 0$ it is perpendicular to the polar axis, and when $C = 0$ it passes through the pole.

In like manner we obtain

Theorem III. *The general equation of the circle in polar coördinates is*

$$(III) \quad \rho^2 + \rho(D \cos \theta + E \sin \theta) + F = 0,$$

where $D, E,$ and F are arbitrary constants.

Corollary. *If the pole is on the circumference and the polar axis passes through the center, the equation is*

$$\rho - 2r \cos \theta = 0,$$

where r is the radius of the circle.

For if the center lies on the polar axis, or X -axis, $E = 0$ (Corollary, p. 131); and if the circle passes through the pole, or origin, $F = 0$. The abscissa of the center equals the radius, and hence (Theorem I, p. 131) $-\frac{D}{2} = r$, or $D = -2r$. Substituting these values of $D, E,$ and F in (III) gives $\rho - 2r \cos \theta = 0$.

Theorem IV. *The length l of the line joining two points $P_1(\rho_1, \theta_1)$ and $P_2(\rho_2, \theta_2)$ is given by*

$$(IV) \quad l^2 = \rho_1^2 + \rho_2^2 - 2\rho_1\rho_2 \cos(\theta_1 - \theta_2).$$

Proof. Let the rectangular coördinates of P_1 and P_2 be respectively (x_1, y_1) and (x_2, y_2) . Then by Theorem I, p. 155,

$$x_1 = \rho_1 \cos \theta_1, \quad x_2 = \rho_2 \cos \theta_2,$$

$$y_1 = \rho_1 \sin \theta_1, \quad y_2 = \rho_2 \sin \theta_2.$$

By Theorem IV, p. 31,

$$l^2 = (x_1 - x_2)^2 + (y_1 - y_2)^2,$$

and hence $l^2 = (\rho_1 \cos \theta_1 - \rho_2 \cos \theta_2)^2 + (\rho_1 \sin \theta_1 - \rho_2 \sin \theta_2)^2$.

Removing parentheses and using 3, p. 19, and 11, p. 20, we obtain (IV). Q. E. D.

PROBLEMS

1. Transform the following equations into polar coördinates and plot their loci.

(a) $x - 3y = 0$.

Ans. $\theta = \tan^{-1}(\frac{1}{3})$.

(b) $y + 5 = 0$.

Ans. $\rho = \frac{-5}{\sin \theta}$.

(c) $x^2 + y^2 = 16$.

Ans. $\rho = \pm 4$.

(d) $x^2 + y^2 - ax = 0$.

Ans. $\rho = a \cos \theta$.

(e) $2xy = 7$.

Ans. $\rho^2 \sin 2\theta = 7$.

(f) $x^2 - y^2 = a^2$.

Ans. $\rho^2 \cos 2\theta = a^2$.

(g) $x \cos \omega + y \sin \omega - p = 0$.

Ans. $\rho \cos(\theta - \omega) - p = 0$.

(h) $(1 - e^2)x^2 + y^2 - 2e^2px - e^2p^2 = 0$.

Ans. $\rho = \frac{ep}{1 - e \cos \theta}$.

(i) $2xy + 4y^2 - 8x + 9 = 0$. *Ans.* $\rho^2(\sin 2\theta + 4 \sin^2 \theta) - 8\rho \cos \theta + 9 = 0$.

2. Transform equations 1 to 21, p. 153, into rectangular coördinates.

3. Find the polar coördinates of the points (3, 4), (-4, 3), (5, -12), (4, 5).

4. Find the rectangular coördinates of the points $(5, \frac{\pi}{2})$, $(-2, \frac{3\pi}{4})$, $(3, \pi)$.

5. Transform into rectangular coördinates $\rho = \frac{ep}{1 - e \cos \theta}$.

64. Equation of a locus. The equation of a locus may often be found with more ease in polar than in rectangular coördinates, especially if the locus is described by the end of a line of variable length revolving about a fixed point. The steps in the process of finding the polar equation of a locus correspond to those in the Rule on p. 53.

Ex. 1. Find the locus of the middle points of the chords of the circle $C: \rho - 2r \cos \theta = 0$ which pass through the pole which is on the circle.

Solution. Let $P(\rho, \theta)$ be any point on the locus. Then, by hypothesis,

$$OP = \frac{1}{2} OQ,$$

where Q is a point on C .

$$\text{But } OP = \rho \text{ and } OQ = 2r \cos \theta.$$

$$\text{Hence } \rho = r \cos \theta.$$

From the Corollary (p. 156) it is seen that the locus is a circle described on the radius of C through O as a diameter.

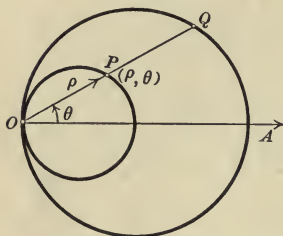

Ex. 2. The radius of a circle is prolonged a distance equal to the ordinate of its extremity. Find the locus of the end of this line.

Solution. Let r be the radius of the circle, let its center be the pole, and let $P(\rho, \theta)$ be any point on the locus. Then, by hypothesis,

$$OP = OB + CB.$$

$$\text{But } OP = \rho,$$

$$OB = r,$$

$$\text{and } CB = r \sin \theta.$$

Hence the equation of the locus of P is

$$\rho = r + r \sin \theta.$$

The locus of this equation is called a **cardioid**.

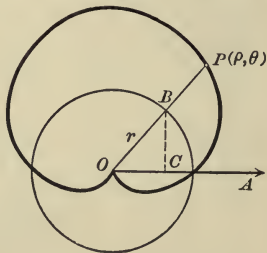

PROBLEMS

1. Chords passing through a fixed point on a circle are extended their own lengths. Find the locus of their extremities.

Ans. A circle whose radius is a diameter of the given circle.

2. Chords of the circle $\rho = 10 \cos \theta$ which pass through the pole are extended 10 units. Find the locus of the extremities of these lines.

Ans. $\rho = 10(1 + \cos \theta)$.

3. Chords of the circle $\rho = 2a \cos \theta$ which pass through the pole are extended a distance $2b$. Find the locus of their extremities.

Ans. $\rho = 2(b + a \cos \theta)$.

4. Find the locus of the middle points of the lines drawn from a fixed point to a given circle.

Hint. Take the fixed point for the pole and let the polar axis pass through the center of the circle.

Ans. A circle whose radius is half that of the given circle and whose center is midway between the pole and the center of the given circle.

5. A line is drawn from a fixed point O meeting a fixed line in P_1 . Find the locus of a point P on this line such that $OP_1 \cdot OP = a^2$. *Ans.* A circle.

6. A line is drawn through a fixed point O meeting a fixed circle in P_1 and P_2 . Find the locus of a point P on this line such that

$$OP = 2 \frac{OP_1 \cdot OP_2}{OP_1 + OP_2}. \quad \text{Ans. A straight line.}$$

CHAPTER VII

TRANSFORMATION OF COÖRDINATES

65. When we are at liberty to choose the axes as we please we generally choose them so that our results shall have the simplest possible form. When the axes are given it is important that we be able to find the equation of a given curve referred to some other axes. The operation of changing from one pair of axes to a second pair is known as a **transformation of coördinates**. We regard the axes as moved from their given position to a new position and we seek formulas which express the old coördinates in terms of the new coördinates.

66. **Translation of the axes.** If the axes be moved from a first position OX and OY to a second position $O'X'$ and $O'Y'$ such that $O'X'$ and $O'Y'$ are respectively parallel to OX and OY , then the axes are said to be **translated** from the first to the second position.

Let the new origin be $O'(h, k)$ and let the coördinates of any point P before and after the translation be respectively (x, y)

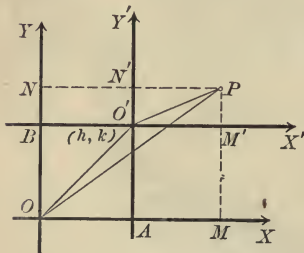

and (x', y') . Projecting OP and $OO'P$ on OX , we obtain (Theorem XI, p. 48)

$$x = x' + h.$$

Similarly, $y = y' + k.$

Hence,

Theorem I. *If the axes be translated to a new origin (h, k) , and if (x, y) and (x', y') are respectively the coördinates of any point P before and after the translation, then*

$$(I) \quad \begin{cases} x = x' + h, \\ y = y' + k. \end{cases}$$

Equations (I) are called the equations for translating the axes. To find the equation of a curve referred to the new axes when its equation referred to the old axes is given, we substitute the values of x and y given by (I) in the given equation. For the given equation expresses the fact that $P(x, y)$ lies on the given curve, and since equations (I) are true for *all* values of (x, y) , the new equation gives a relation between x' and y' which expresses that $P(x', y')$ lies on the curve and is therefore (p. 53) the equation of the curve in the new coördinates.

Ex. 1. Transform the equation

$$x^2 + y^2 - 6x + 4y - 12 = 0$$

when the axes are translated to the new origin $(3, -2)$.

Solution. Here $h = 3$ and $k = -2$, so equations (I) become

$$x = x' + 3, y = y' - 2.$$

Substituting in the given equation, we obtain

$$(x' + 3)^2 + (y' - 2)^2 - 6(x' + 3) + 4(y' - 2) - 12 = 0,$$

or, reducing, $x'^2 + y'^2 = 25$.

This result could easily be foreseen. For the locus of the given equation is (Theorem I, p. 131) a circle whose center is $(3, -2)$ and whose radius is 5. When the origin is translated to the center the equation of the circle must necessarily have the form obtained (Corollary, p. 58).

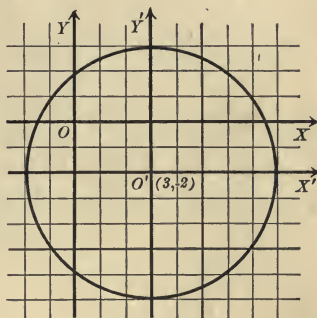

PROBLEMS

1. Find the new coördinates of the points $(3, -5)$ and $(-4, 2)$ when the axes are translated to the new origin $(3, 6)$.

2. Transform the following equations when the axes are translated to the new origin indicated and plot both pairs of axes and the curve.

(a) $3x - 4y = 6, (2, 0)$. *Ans.* $3x' - 4y' = 0$.

(b) $x^2 + y^2 - 4x - 2y = 0, (2, 1)$. *Ans.* $x'^2 + y'^2 = 5$.

(c) $y^2 - 6x + 9 = 0, (\frac{3}{2}, 0)$. *Ans.* $y'^2 = 6x'$.

(d) $x^2 + y^2 - 1 = 0, (-3, -2)$. *Ans.* $x'^2 + y'^2 - 6x' - 4y' + 12 = 0$.

(e) $y^2 - 2kx + k^2 = 0, (\frac{k}{2}, 0)$. *Ans.* $y'^2 = 2kx'$.

(f) $x^2 - 4y^2 + 8x + 24y - 20 = 0, (-4, 3)$. *Ans.* $x'^2 - 4y'^2 = 0$.

3. Derive equations (I) if O' is in (a) the second quadrant; (b) the third quadrant; (c) the fourth quadrant.

67. Rotation of the axes. Let the axes OX and OY be rotated about O through an angle θ to the positions OX' and OY' . The equations giving the coördinates of any point referred to OX and OY in terms of its coördinates referred to OX' and OY' are called the equations for rotating the axes.

Theorem II. *The equations for rotating the axes through an angle θ are*

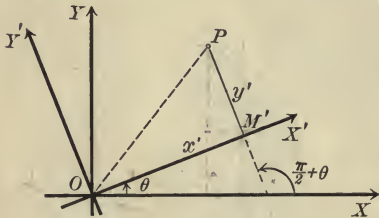

$$(II) \quad \begin{cases} x = x' \cos \theta - y' \sin \theta, \\ y = x' \sin \theta + y' \cos \theta. \end{cases}$$

Proof. Let P be any point whose old and new coördinates are respectively (x, y) and (x', y') . Draw OP and draw PM' perpendicular to OX' . Project OP and $OM'P$ on OX .

The proj. of OP on $OX = x$. (Theorem III, p. 31)

The proj. of OM' on $OX = x' \cos \theta$. (Theorem II, p. 30)

The proj. of $M'P$ on $OX = y' \cos \left(\frac{\pi}{2} + \theta \right)$. (Theorem II, p. 30)
 $= -y' \sin \theta$. (by 6, p. 20)

Hence (Theorem XI, p. 48)

$$x = x' \cos \theta - y' \sin \theta.$$

In like manner, projecting OP and $OM'P$ on OY , we obtain

$$\begin{aligned} y &= x' \cos \left(\frac{\pi}{2} - \theta \right) + y' \cos \theta \\ &= x' \sin \theta + y' \cos \theta. \end{aligned}$$

Q. E. D.

If the equation of a curve in x and y is given, we substitute from (II) in order to find the equation of the same curve referred to OX' and OY' .

Ex. 1. Transform the equation $x^2 - y^2 = 16$ when the axes are rotated through $\frac{\pi}{4}$.

Solution. Since

$$\sin \frac{\pi}{4} = \frac{1}{2} \sqrt{2} = \frac{1}{\sqrt{2}}$$

and $\cos \frac{\pi}{4} = \frac{1}{\sqrt{2}},$

equations (II) become

$$x = \frac{x' - y'}{\sqrt{2}}, \quad y = \frac{x' + y'}{\sqrt{2}}.$$

Substituting in the given equation, we obtain

$$\left(\frac{x' - y'}{\sqrt{2}}\right)^2 - \left(\frac{x' + y'}{\sqrt{2}}\right)^2 = 16,$$

or, simplifying,

$$x'y' + 8 = 0.$$

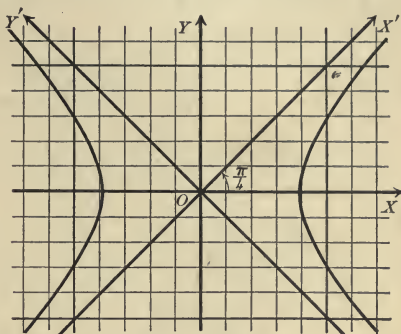

PROBLEMS

1. Find the coördinates of the points (3, 1), (-2, 6), and (4, -1) when the axes are rotated through $\frac{\pi}{2}$.

2. Transform the following equations when the axes are rotated through the indicated angle. Plot both pairs of axes and the curve.

(a) $x - y = 0, \quad \frac{\pi}{4}.$

Ans. $y' = 0.$

(b) $x^2 + 2xy + y^2 = 8, \quad \frac{\pi}{4}.$

Ans. $x'^2 = 4.$

(c) $y^2 = 4x, \quad -\frac{\pi}{2}.$

Ans. $x'^2 = 4y'.$

(d) $x^2 + 4xy + y^2 = 16, \quad \frac{\pi}{4}.$

Ans. $3x'^2 - y'^2 = 16.$

(e) $x^2 + y^2 = r^2, \quad \theta.$

Ans. $x'^2 + y'^2 = r^2.$

(f) $x^2 + 2xy + y^2 + 4x - 4y = 0, \quad -\frac{\pi}{4}.$

Ans. $\sqrt{2}y'^2 + 4x' = 0.$

3. Derive equations (II) if θ is obtuse.

68. General transformation of coördinates. If the axes are moved in any manner, they may be brought from the old position to the new position by translating them to the new origin and then rotating them through the proper angle.

Theorem III. *If the axes be translated to a new origin (h, k) and then rotated through an angle θ , the equations of the transformation of coördinates are*

$$(III) \quad \begin{cases} x = x' \cos \theta - y' \sin \theta + h, \\ y = x' \sin \theta + y' \cos \theta + k. \end{cases}$$

Proof. To translate the axes to $O'X''$ and $O'Y''$ we have, by (I),

$$x = x'' + h,$$

$$y = y'' + k,$$

where (x'', y'') are the coördinates of any point P referred to $O'X''$ and $O'Y''$.

To rotate the axes we set, by (II),

$$x'' = x' \cos \theta - y' \sin \theta,$$

$$y'' = x' \sin \theta + y' \cos \theta.$$

Substituting these values of x'' and y'' , we obtain (III). Q.E.D.

69. Classification of loci. The loci of algebraic equations (p. 17) are classified according to the *degree* of the equations. This classification is justified by the following theorem, which shows that the degree of the equation of a locus is the same no matter how the axes are chosen.

Theorem IV. *The degree of the equation of a locus is unchanged by a transformation of coördinates.*

Proof. Since equations (III) are of the first degree in x' and y' , the degree of an equation cannot be *raised* when the values of x and y given by (III) are substituted. Neither can the degree be *lowered*; for then the degree must be raised if we transform back to the old axes, and we have seen that it cannot be raised by changing the axes.*

As the degree can neither be raised nor lowered by a transformation of coördinates, it must remain unchanged. Q.E.D.

* This also follows from the fact that when equations (III) are solved for x' and y' the results are of the first degree in x and y .

70. Simplification of equations by transformation of coördinates. The principal use made of transformation of coördinates is to discuss the various forms in which the equation of a curve may be put. In particular, they enable us to deduce *simple* forms to which an equation may be reduced.

Rule to simplify the form of an equation.

First step. Substitute the values of x and y given by (I) [or (II)] and collect like powers of x' and y' .

Second step. Set equal to zero the coefficients of two terms obtained in the first step which contain h and k (or one coefficient containing θ).

Third step. Solve the equations obtained in the second step for h and k^* (or θ).

Fourth step. Substitute these values for h and k (or θ) in the result of the first step. The result will be the required equation.

In many examples it is necessary to apply the rule twice in order to rotate the axes, and then translate them, or *vice versa*. It is usually simpler to do this than to employ equations (III) in the Rule and do both together. Just what coefficients are set equal to zero in the second step will depend on the object in view.

It is often convenient to drop the primes in the new equation and remember that the equation is referred to the new axes.

Ex. 1. Simplify the equation $y^2 - 8x + 6y + 17 = 0$ by translating the axes.

Solution. First step. Set $x = x' + h$ and $y = y' + k$.

This gives $(y' + k)^2 - 8(x' + h) + 6(y' + k) + 17 = 0$, or

$$(1) \quad \begin{array}{r|l} y'^2 - 8x' + 2k & y' + k^2 \\ + 6 & - 8h \\ & + 6k \\ & + 17 \end{array} \dagger = 0.$$

* It may not be possible to solve these equations (Theorem IV, p. 90).

† These vertical bars play the part of parentheses. Thus $2k + 6$ is the coefficient of y' and $k^2 - 8h + 6k + 17$ is the constant term. Their use enables us to collect like powers of x' and y' at the same time that we remove the parentheses in the preceding equation.

Second step. Setting the coefficient of y' and the constant term, the only coefficients containing h and k , equal to zero, we obtain

$$(2) \quad 2k + 6 = 0,$$

$$(3) \quad k^2 - 8h + 6k + 17 = 0.$$

Third step. Solving (2) and (3) for h and k , we find

$$k = -3, \quad h = 1.$$

Fourth step. Substituting in (1), remembering that h and k satisfy (2) and (3), we have

$$y'^2 - 8x' = 0.$$

The locus is the parabola plotted in the figure which shows the new and old axes.

Ex. 2. Simplify $x^2 + 4y^2 - 2x - 16y + 1 = 0$ by translating the axes.

Solution. First step. Set $x = x' + h$, $y = y' + k$. This gives

$$(4) \quad \begin{array}{r|l} x'^2 + 4y'^2 + 2h & x' + 8k \\ -2 & -16 \\ & + 4k^2 \\ & - 2h \\ & - 16k \\ & + 1 \end{array} = 0.$$

Second step. Set the coefficients of x' and y' equal to zero. This gives

$$2h - 2 = 0, \quad 8k - 16 = 0.$$

Third step. Solving, we obtain

$$h = 1, \quad k = 2.$$

Fourth step. Substituting in (4), we obtain

$$x'^2 + 4y'^2 = 16.$$

Plotting on the new axes, we obtain the figure.

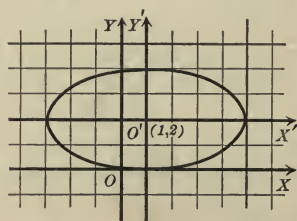

Ex. 3. Remove the xy -term from $x^2 + 4xy + y^2 = 4$ by rotating the axes.

Solution. First step. Set $x = x' \cos \theta - y' \sin \theta$ and $y = x' \sin \theta + y' \cos \theta$, whence

$$\begin{array}{r|l} \cos^2 \theta & x'^2 - 2 \sin \theta \cos \theta \\ + 4 \sin \theta \cos \theta & + 4 (\cos^2 \theta - \sin^2 \theta) \\ + \sin^2 \theta & + 2 \sin \theta \cos \theta \end{array} \left| \begin{array}{l} x'y' + \sin^2 \theta \\ - 4 \sin \theta \cos \theta \\ + \cos^2 \theta \end{array} \right| y'^2 = 4.$$

or, by 3, p. 19, and 14, p. 20,

$$(5) \quad (1 + 2 \sin 2\theta) x'^2 + 4 \cos 2\theta \cdot x'y' + (1 - 2 \sin 2\theta) y'^2 = 4.$$

Second step. Setting the coefficient of $x'y'$ equal to zero, we have

$$\cos 2\theta = 0.$$

Third step. Hence

$$2\theta = \frac{\pi}{2} \therefore \theta = \frac{\pi}{4}.$$

Fourth step. Substituting in (5), we obtain, since $\sin \frac{\pi}{2} = 1$ (p. 21),

$$3x'^2 - y'^2 = 4.$$

The locus of this equation is the hyperbola plotted on the new axes in the figure.

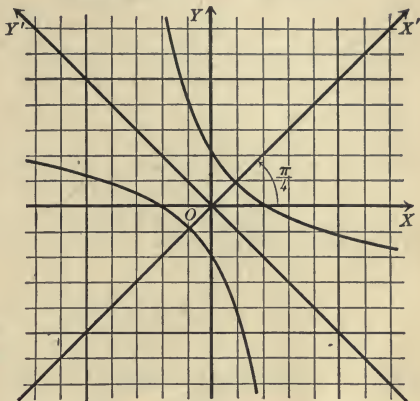

From $\cos 2\theta = 0$ we get, in general, $2\theta = \frac{\pi}{2} + n\pi$, where n is any positive or negative integer, or zero, and hence $\theta = \frac{\pi}{4} + n\frac{\pi}{2}$. Then the xy -term may be removed by giving θ any one of these values. For most purposes we choose the smallest positive value of θ as in this example.

Ex. 4. Simplify $x^3 + 6x^2 + 12x - 4y + 4 = 0$ by translating the axes.

Solution. First step. Set

$$x = x' + h, \quad y = y' + k.$$

We obtain

$$(6) \quad \begin{array}{r|l} x'^3 + 3h & x'^2 + 3h^2 \\ + 6 & + 12h \\ & + 12 \end{array} \left| \begin{array}{l} x' - 4y' + h^3 \\ + 6h^2 \\ + 12h \\ - 4k \\ + 4 \end{array} \right| = 0.$$

Second step. Set equal to zero the coefficient of x'^2 and the constant term. This gives

$$3h + 6 = 0,$$

$$h^3 + 6h^2 + 12h - 4k + 4 = 0.$$

Third step. Solving,

$$h = -2, \quad k = -1.$$

Fourth step. Substituting in (6), we obtain

$$x'^3 - 4y' = 0,$$

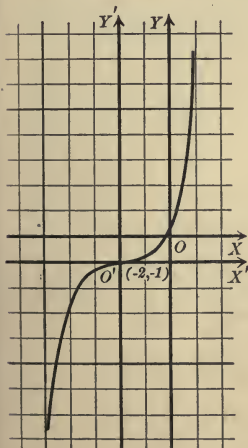

whose locus is the cubical parabola in the figure.

PROBLEMS

1. Simplify the following equations by translating the axes. Plot both pairs of axes and the curve.

- | | |
|----------------------------------------------|-------------------------------------|
| (a) $x^2 + 6x + 8 = 0.$ | <i>Ans.</i> $x'^2 = 1.$ |
| (b) $x^2 - 4y + 8 = 0.$ | <i>Ans.</i> $x'^2 = 4y'.$ |
| (c) $x^2 + y^2 + 4x - 6y - 3 = 0.$ | <i>Ans.</i> $x'^2 + y'^2 = 16.$ |
| (d) $y^2 - 6x - 10y + 19 = 0.$ | <i>Ans.</i> $y'^2 = 6x'.$ |
| (e) $x^2 - y^2 + 8x - 14y - 33 = 0.$ | <i>Ans.</i> $x'^2 - y'^2 = 0.$ |
| (f) $x^2 + 4y^2 - 16x + 24y + 84 = 0.$ | <i>Ans.</i> $x'^2 + 4y'^2 = 16.$ |
| (g) $y^3 + 8x - 40 = 0.$ | <i>Ans.</i> $8x' + y'^3 = 0.$ |
| (h) $x^3 - y^2 + 14y - 49 = 0.$ | <i>Ans.</i> $y'^2 = x'^3.$ |
| (i) $4x^2 - 4xy + y^2 - 40x + 24y + 99 = 0.$ | <i>Ans.</i> $(2x' - y')^2 - 1 = 0.$ |

2. Remove the xy -term from the following equations by rotating the axes. Plot both pairs of axes and the curve.

- | | |
|------------------------------------------|---------------------------------------|
| (a) $x^2 - 2xy + y^2 = 12.$ | <i>Ans.</i> $y'^2 = 6.$ |
| (b) $x^2 - 2xy + y^2 + 8x + 8y = 0.$ | <i>Ans.</i> $\sqrt{2}y'^2 + 8x' = 0.$ |
| (c) $xy = 18.$ | <i>Ans.</i> $x'^2 - y'^2 = 36.$ |
| (d) $25x^2 + 14xy + 25y^2 = 288.$ | <i>Ans.</i> $16x'^2 + 9y'^2 = 144.$ |
| (e) $3x^2 - 10xy + 3y^2 = 0.$ | <i>Ans.</i> $x'^2 - 4y'^2 = 0.$ |
| (f) $6x^2 + 20\sqrt{3}xy + 26y^2 = 324.$ | <i>Ans.</i> $9x'^2 - y'^2 = 81.$ |

71. Application to equations of the first and second degrees.

In this section we shall apply the Rule of the preceding section to the proof of some general theorems.

Theorem V. *By moving the axes the general equation of the first degree,*

$$Ax + By + C = 0,$$

may be transformed into $x' = 0.$

Proof. Apply the Rule on p. 165, using equations (III).

Set

$$x = x' \cos \theta - y' \sin \theta + h,$$

$$y = x' \sin \theta + y' \cos \theta + k.$$

This gives

$$(1) \quad \left. \begin{array}{l} A \cos \theta \left| x' - A \sin \theta \right| y' + Ah \\ + B \sin \theta \left| \quad + B \cos \theta \right| \quad + Bk \\ \quad \quad \quad \quad \quad \quad \quad \quad + C \end{array} \right| = 0.$$

Setting the coefficient of y' and the constant term equal to zero gives

$$(2) \quad -A \sin \theta + B \cos \theta = 0,$$

$$(3) \quad Ah + Bk + C = 0.$$

From (2), $\tan \theta = \frac{B}{A}$, or $\theta = \tan^{-1} \left(\frac{B}{A} \right)$.

From (3) we can determine many pairs of values of h and k . One pair is

$$h = -\frac{C}{A}, \quad k = 0.$$

Substituting in (1) the last two terms drop out, and dividing by the coefficient of x' we have left $x' = 0$. Q. E. D.

We have moved the origin to a point (h, k) on the given line L , since (3) is the condition that (h, k) lies on the line, and then rotated the axes until the new axis of y coincides with L . The particular point chosen for (h, k) was the point O' where L cuts the X -axis.

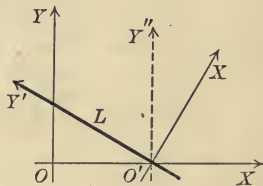

This theorem is evident geometrically. For $x' = 0$ is the equation of the new Y -axis, and evidently any line may be chosen as the Y -axis. But the theorem may be used to prove that the locus of every equation of the first degree is a straight line, if we prove it as above, for it is evident that the locus of $x' = 0$ is a straight line.

Theorem VI. *The term in xy may always be removed from an equation of the second degree,*

$$Ax^2 + Bxy + Cy^2 + Dx + Ey + F = 0,$$

by rotating the axes through an angle θ such that

$$(VI) \quad \tan 2\theta = \frac{B}{A - C}.$$

Proof. Set $x = x' \cos \theta - y' \sin \theta$
and $y = x' \sin \theta + y' \cos \theta.$

This gives

$$(4) \quad \begin{array}{l} A \cos^2 \theta \\ + B \sin \theta \cos \theta \\ + C \sin^2 \theta \end{array} \left| \begin{array}{l} x'^2 - 2 A \sin \theta \cos \theta \\ + B(\cos^2 \theta - \sin^2 \theta) \\ + 2 C \sin \theta \cos \theta \end{array} \right| \begin{array}{l} x'y' + A \sin^2 \theta \\ - B \sin \theta \cos \theta \\ + C \cos^2 \theta \end{array} \left| \begin{array}{l} y'^2 \\ \\ \end{array} \right| \\ + D \cos \theta \left| \begin{array}{l} x' - D \sin \theta \\ + E \sin \theta \end{array} \right| y' + F = 0.$$

Setting the coefficient of $x'y'$ equal to zero, we have

$$(C - A) 2 \sin \theta \cos \theta + B(\cos^2 \theta - \sin^2 \theta) = 0,$$

or (14, p. 20), $(C - A) \sin 2 \theta + B \cos 2 \theta = 0.$

Hence $\tan 2 \theta = \frac{B}{A - C}.$

If θ satisfies this relation, on substituting in (4) we obtain an equation without the term in xy . Q. E. D.

Corollary. *In transforming an equation of the second degree by rotating the axes the constant term is unchanged unless the new equation is multiplied or divided by some constant.*

For the constant term in (4) is the same as that of the given equation.

Theorem VII. *The terms of the first degree may be removed from an equation of the second degree,*

$$Ax^2 + Bxy + Cy^2 + Dx + Ey + F = 0,$$

by translating the axes, provided that the discriminant of the terms of the second degree, $\Delta = B^2 - 4AC$, is not zero.

Proof. Set $x = x' + h, y = y' + k.$

This gives

$$(5) \quad \begin{array}{l} Ax'^2 + Bx'y' + Cy'^2 + 2 Ah \\ + Bk \\ + D \end{array} \left| \begin{array}{l} x' + Bh \\ + 2 Ck \\ + E \end{array} \right| \begin{array}{l} y' + Ah^2 \\ + Bhk \\ + Ck^2 \\ + Dh \\ + Ek \\ + F \end{array} \left| \begin{array}{l} \\ \\ \end{array} \right| = 0.$$

Setting equal to zero the coefficients of x' and y' , we obtain

$$(6) \quad 2Ah + Bk + D = 0,$$

$$(7) \quad Bh + 2Ck + E = 0.$$

These equations can be solved for h and k unless (Theorem IV, p. 90)

$$\frac{2A}{B} = \frac{B}{2C},$$

or
$$B^2 - 4AC = 0.$$

If the values obtained be substituted in (5), the resulting equation will not contain the terms of the first degree. Q. E. D.

Corollary I. *If an equation of the second degree be transformed by translating the axes, the coefficients of the terms of the second degree are unchanged unless the new equation be multiplied or divided by some constant.*

For these coefficients in (5) are the same as in the given equation.

Corollary II. *When Δ is not zero the locus of an equation of the second degree has a center of symmetry.*

For if the terms of the first degree be removed the locus will be symmetrical with respect to the new origin (Theorem V, p. 73).

If $\Delta = B^2 - 4AC = 0$, equations (6) and (7) may still be solved for h and k if (Theorem IV, p. 90) $\frac{2A}{B} = \frac{B}{2C} = \frac{D}{E}$, when the new origin (h, k) may be any point on the line $2Ax + By + D = 0$. In this case every point on that line will be a center of symmetry.

For example, consider $x^2 + 4xy + 4y^2 + 4x + 8y + 3 = 0$. For this equation equations (6) and (7) become

$$2h + 4k + 4 = 0,$$

$$4h + 8k + 8 = 0.$$

In these equations the coefficients are all proportional and there is an infinite number of solutions. One solution is $h = -2, k = 0$. For these values the given equation reduces to

$$x^2 + 4xy + 4y^2 - 1 = 0,$$

or
$$(x + 2y + 1)(x + 2y - 1) = 0.$$

The locus consists of two parallel lines and evidently is symmetrical with respect to any point on the line midway between those lines.

MISCELLANEOUS PROBLEMS

1. Simplify and plot.

(a) $y^2 - 5y + 6 = 0$.

(e) $x^2 + 4xy + y^2 = 8$.

(b) $x^2 + 2xy + y^2 - 6x - 6y + 5 = 0$.

(f) $x^2 - 9y^2 - 2x - 36y + 4 = 0$.

(c) $y^2 + 6x - 10y + 2 = 0$.

(g) $25y^2 - 16x^2 + 50y - 119 = 0$.

(d) $x^2 + 4y^2 - 8x - 16y = 0$.

(h) $x^2 + 2xy + y^2 - 8x = 0$.

2. Find the point to which the origin must be moved to remove the terms of the first degree from an equation of the second degree (Theorem VII).

3. To what point (h, k) must we translate the axes to transform

$$(1 - e^2)x^2 + y^2 - 2px + p^2 = 0 \text{ into } (1 - e^2)x^2 + y^2 - 2e^2px - e^2p^2 = 0?$$

4. Simplify the second equation in problem 3.

5. Derive from a figure the equations for rotating the axes through $+\frac{\pi}{2}$ and $-\frac{\pi}{2}$, and verify by substitution in (II), p. 162.

6. Prove that every equation of the first degree may be transformed into $y' = 0$ by moving the axes. In how many ways is this possible?

7. The equation for rotating the polar axis through an angle ϕ is $\theta = \theta' + \phi$.

8. The equations of transformation from rectangular to polar coördinates, when the pole is the point (h, k) and the polar axis makes an angle of ϕ with the X -axis, are

$$x = h + \rho \cos(\theta + \phi),$$

$$y = k + \rho \sin(\theta + \phi).$$

9. The equations of transformation from rectangular coördinates to oblique coördinates are

$$x = x' + y' \cos \omega,$$

$$y = y' \sin \omega,$$

if the X -axes coincide and the angle between OX' and OY' is ω .

10. The equations of transformation from one set of oblique axes to any other set with the same origin are

$$x = x' \frac{\sin(\omega - \phi)}{\sin \omega} + y' \frac{\sin(\omega - \psi)}{\sin \omega},$$

$$y = x' \frac{\sin \phi}{\sin \omega} + y' \frac{\sin \psi}{\sin \omega},$$

where ω is the angle between OX and OY , ϕ is the angle from OX to OX' , and ψ is the angle from OX to OY' .

CHAPTER VIII

CONIC SECTIONS AND EQUATIONS OF THE SECOND DEGREE

72. Equation in polar coördinates. The locus of a point P is called a **conic section*** if the ratio of its distances from a fixed point F and a fixed line DD is constant. F is called the **focus**, DD the **directrix**, and the constant ratio the **eccentricity**. The line through the focus perpendicular to the directrix is called the **principal axis**.

Theorem I. *If the pole is the focus and the polar axis the principal axis of a conic section, then the polar equation of the conic is*

$$(I) \quad \rho = \frac{ep}{1 - e \cos \theta},$$

where e is the eccentricity and p is the distance from the directrix to the focus.

Proof. Let P be any point on the conic. Then, by definition,

$$\frac{FP}{EP} = e.$$

From the figure, $FP = \rho$

and $EP = HM = p + \rho \cos \theta$.

Substituting these values of FP and EP , we have

$$\frac{\rho}{p + \rho \cos \theta} = e;$$

or, solving for ρ ,

$$\rho = \frac{ep}{1 - e \cos \theta}.$$

Q. E. D.

* Because these curves may be regarded as the intersections of a cone of revolution with a plane.

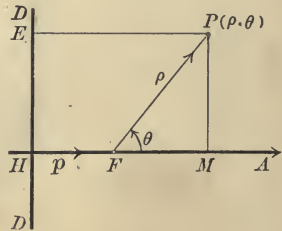

From (I) we see that

1. A conic is symmetrical with respect to the principal axis.

For substituting $-\theta$ for θ changes only the form of the equation, since $\cos(-\theta) = \cos \theta$.

2. In plotting, no values of θ need be excluded.

The other properties to be discussed (p. 151) show that three cases must be considered according as $e \geq 1$.

The parabola $e = 1$. When $e = 1$, (I) becomes

$$\rho = \frac{p}{1 - \cos \theta},$$

and the locus is called a parabola.

1. For $\theta = 0$ $\rho = \infty$, and for $\theta = \pi$ $\rho = \frac{p}{2}$. The parabola therefore crosses the principal axis but once at the point O , called the **vertex**, which is $\frac{p}{2}$ to the left of the focus F , or midway between F and DD .

2. ρ becomes infinite when the denominator, $1 - \cos \theta$, vanishes. If $1 - \cos \theta = 0$, then $\cos \theta = 1$; and hence, $\theta = 0$ is the only value less than 2π for which ρ is infinite.

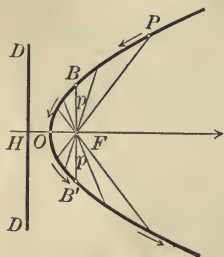

3. When θ increases from 0 to $\frac{\pi}{2}$,
 then $\cos \theta$ decreases from 1 to 0,
 $1 - \cos \theta$ increases from 0 to 1,
 ρ decreases from ∞ to p ,
 and the point $P(\rho, \theta)$ describes the parabola
 from infinity to B .

When θ increases from $\frac{\pi}{2}$ to π ,

then $\cos \theta$ decreases from 0 to -1 ,
 $1 - \cos \theta$ increases from 1 to 2,
 ρ decreases from p to $\frac{p}{2}$,

and the point $P(\rho, \theta)$ describes the parabola from B to the vertex O .

On account of the symmetry with respect to the axis, when θ increases from π to $\frac{3\pi}{2}$, $P(\rho, \theta)$ describes the parabola from O to B' ; and when θ increases from $\frac{3\pi}{2}$ to 2π , from B' to infinity.

When $e < 1$ the conic is called an **ellipse**, and when $e > 1$, an **hyperbola**. The points of similarity and difference in these curves are brought out by considering them simultaneously.

The ellipse, $e < 1$.

1. For $\theta = 0$ $\rho = \frac{ep}{1-e} = \frac{e}{1-e}p$.

As $e < 1$, the denominator, and hence ρ , is positive, so that we obtain a point A on the ellipse to the *right* of F .

As $\frac{e}{1-e} \gtrless 1$ when $e < 1$, according as $e \gtrless \frac{1}{2}$, then FA may be greater, equal to, or less than FH .

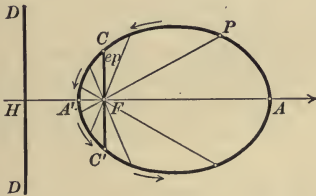

For $\theta = \pi$ $\rho = \frac{ep}{1+e} = \frac{e}{1+e}p$. ρ is positive, and hence we obtain a point A' to the *left* of F .

As $\frac{e}{1+e} < 1$, then $\rho < p$; so A' lies between H and F .

A and A' are called the **vertices** of the ellipse.

The hyperbola, $e > 1$.

1. For $\theta = 0$ $\rho = \frac{ep}{1-e} = \frac{e}{1-e}p$.

As $e > 1$, the denominator, and hence ρ , is negative, so that we obtain a point A on the hyperbola to the *left* of F .

As $\frac{e}{1-e} > 1$ (numerically) when $e > 1$, then $\rho > p$; so A lies to the left of H .

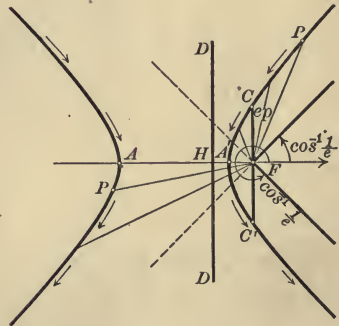

For $\theta = \pi$ $\rho = \frac{ep}{1+e} = \frac{e}{1+e}p$. ρ is positive, and hence we obtain a second point A' to the left of F .

As $\frac{e}{1+e} < 1$, then $\rho < p$; so A' lies between H and F .

A and A' are called the **vertices** of the hyperbola.

The ellipse, $e < 1$.

2. ρ becomes infinite if

$$1 - e \cos \theta = 0,$$

or
$$\cos \theta = \frac{1}{e}.$$

As $e < 1$, then $\frac{1}{e} > 1$; and hence there are *no* values of θ for which ρ becomes infinite.

3. When

$$\theta \text{ increases from } 0 \text{ to } \frac{\pi}{2},$$

then $\cos \theta$ decreases from 1 to 0,

$1 - e \cos \theta$ increases from $1 - e$ to 1;

hence ρ decreases from $\frac{ep}{1-e}$ to ep ,

and $P(\rho, \theta)$ describes the ellipse from A to C .

When θ increases from $\frac{\pi}{2}$ to π ,

then $\cos \theta$ decreases from 0 to -1 ,

$1 - e \cos \theta$ increases from 1 to $1 + e$;

hence ρ decreases from ep to $\frac{ep}{1+e}$,

and $P(\rho, \theta)$ describes the ellipse from C to A' .

The rest of the ellipse, $A'C'A$, may be obtained from the symmetry with respect to the principal axis.

The ellipse is a *closed curve*.

The hyperbola, $e > 1$.

2. ρ becomes infinite if

$$1 - e \cos \theta = 0,$$

or
$$\cos \theta = \frac{1}{e}.$$

As $e > 1$, then $\frac{1}{e} < 1$; and hence there are *two* values of θ for which ρ becomes infinite.

3. When

$$\theta \text{ increases from } 0 \text{ to } \cos^{-1}\left(\frac{1}{e}\right),$$

then $\cos \theta$ decreases from 1 to $\frac{1}{e}$,

$1 - e \cos \theta$ increases from $1 - e$ to 0;

hence ρ decreases from $\frac{ep}{1-e}$ to $-\infty$,

and $P(\rho, \theta)$ describes the lower half of the left-hand branch from A to infinity.

When

$$\theta \text{ increases from } \cos^{-1}\left(\frac{1}{e}\right) \text{ to } \frac{\pi}{2},$$

then $\cos \theta$ decreases from $\frac{1}{e}$ to 0,

$1 - e \cos \theta$ increases from 0 to 1;

hence ρ decreases from ∞ to ep ,

and $P(\rho, \theta)$ describes the upper part of the right-hand branch from infinity to C .

When θ increases from $\frac{\pi}{2}$ to π ,

then $\cos \theta$ decreases from 0 to -1 ,

$1 - e \cos \theta$ increases from 1 to $1 + e$;

hence ρ decreases from ep to $\frac{ep}{1+e}$,

and $P(\rho, \theta)$ describes the hyperbola from C to A' .

The rest of the hyperbola, $A'C'$ to infinity and infinity to A , may be obtained from the symmetry with respect to the principal axis.

The hyperbola has *two infinite branches*.

PROBLEMS

1. Plot and discuss the following conics. Find e and p , and draw the focus and directrix of each.

(a) $\rho = \frac{2}{1 - \cos \theta}$.

(e) $\rho = \frac{3}{3 - \cos \theta}$.

(b) $\rho = \frac{2}{1 - \frac{1}{2} \cos \theta}$.

(f) $\rho = \frac{6}{2 - 3 \cos \theta}$.

(c) $\rho = \frac{8}{1 - 2 \cos \theta}$.

(g) $\rho = \frac{2}{2 - \cos \theta}$.

(d) $\rho = \frac{5}{2 - 2 \cos \theta}$.

(h) $\rho = \frac{12}{3 - 4 \cos \theta}$.

2. Transform the equations in problem 1 into rectangular coördinates, simplify by the Rule on p. 165, and discuss the resulting equations. Find the coördinates of the focus and the equation of the directrix in the new variables. Plot the locus of each equation, its focus, and directrix on the new axes.

Ans. (a) $y^2 = 4x$, $(1, 0)$, $x = -1$.

(b) $\frac{x^2}{\frac{6.4}{9}} + \frac{y^2}{\frac{1.6}{3}} = 1$, $(-\frac{4}{3}, 0)$, $x = -\frac{16}{3}$.

(c) $\frac{x^2}{\frac{6.4}{9}} - \frac{y^2}{\frac{6.4}{3}} = 1$, $(\frac{16}{3}, 0)$, $x = \frac{4}{3}$.

(d) $y^2 = 5x$, $(\frac{5}{4}, 0)$, $x = -\frac{5}{4}$.

(e) $\frac{x^2}{\frac{8.1}{6.4}} + \frac{y^2}{\frac{9}{8}} = 1$, $(-\frac{3}{8}, 0)$, $x = -\frac{27}{8}$.

(f) $\frac{x^2}{\frac{1.44}{2.5}} - \frac{y^2}{\frac{3.6}{5}} = 1$, $(\frac{18}{5}, 0)$, $x = \frac{8}{5}$.

(g) $\frac{x^2}{\frac{1.6}{9}} + \frac{y^2}{\frac{4}{3}} = 1$, $(-\frac{2}{3}, 0)$, $x = -\frac{8}{3}$.

(h) $\frac{x^2}{\frac{1.296}{4.9}} - \frac{y^2}{\frac{1.44}{7}} = 1$, $(\frac{48}{7}, 0)$, $x = \frac{27}{7}$.

3. Transform (I) into rectangular coördinates, simplify, and find the coördinates of the focus and the equation of the directrix in the new rectangular coordinates if (a) $e = 1$, (b) $e \geq 1$.

Ans. (a) $y^2 = 2px$, $(\frac{p}{2}, 0)$, $x = -\frac{p}{2}$

(b) $\frac{x^2}{\frac{e^2 p^2}{(1 - e^2)^2}} + \frac{y^2}{\frac{e^2 p^2}{1 - e^2}} = 1$, $(-\frac{e^2 p}{1 - e^2}, 0)$, $x = -\frac{p}{1 - e^2}$.

4. Derive the equation of a conic section when (a) the focus lies to the left of the directrix; (b) the polar axis is parallel to the directrix.

$$\text{Ans. (a) } \rho = \frac{ep}{1 + e \cos \theta}; \quad \text{(b) } \rho = \frac{ep}{1 - e \sin \theta}.$$

5. Plot and discuss the following conics. Find e and p , and draw the directrix of each.

$$\text{(a) } \rho = \frac{8}{1 + \cos \theta}.$$

$$\text{(c) } \rho = \frac{7}{3 + 10 \cos \theta}.$$

$$\text{(b) } \rho = \frac{6}{1 - \sin \theta}.$$

$$\text{(d) } \rho = \frac{5}{3 - \sin \theta}.$$

73. Transformation to rectangular coördinates.

Theorem II. *If the origin is the focus and the X-axis the principal axis of a conic section, then its equation is*

$$\text{(II) } (1 - e^2)x^2 + y^2 - 2e^2px - e^2p^2 = 0,$$

where e is the eccentricity and $x = -p$ is the equation of the directrix.

Proof. Clearing fractions in (I), p. 173, we obtain

$$\rho - e\rho \cos \theta = ep.$$

Set $\rho = \pm \sqrt{x^2 + y^2}$ and $\rho \cos \theta = x$ (p. 155). This gives

$$\pm \sqrt{x^2 + y^2} - ex = ep,$$

or

$$\pm \sqrt{x^2 + y^2} = ex + ep.$$

Squaring and collecting like powers of x and y , we have the required equation. Since the directrix DD (Fig., p. 173) lies p units to the left of F its equation is $x = -p$. Q. E. D.

74. Simplification and discussion of the equation in rectangular coördinates. The parabola, $e = 1$.

When $e = 1$, (II) becomes

$$y^2 - 2px - p^2 = 0.$$

Applying the Rule on p. 165, we substitute

$$\text{(1) } x = x' + h, \quad y = y' + k,$$

obtaining

$$\text{(2) } y'^2 - 2px' + 2ky' + k^2 - 2ph - p^2 = 0.$$

Set the coefficient of y' and the constant term equal to zero and solve for h and k . This gives

$$(3) \quad h = -\frac{p}{2}, \quad k = 0.$$

Substituting these values in (2) and dropping primes, the equation of the parabola becomes $y^2 = 2px$.

From (3) we see that the origin has been removed from F to O , the vertex of the parabola. It is easily seen that the new coördinates of the focus are $(\frac{p}{2}, 0)$, and the new equation of the directrix is $x = -\frac{p}{2}$. Hence

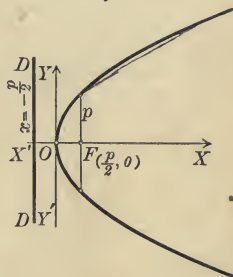

Theorem III. *If the origin is the vertex and the X-axis the axis of a parabola, then its equation is*

$$(III) \quad y^2 = 2px.$$

The focus is the point $(\frac{p}{2}, 0)$, and the equation of the directrix is $x = -\frac{p}{2}$.

A general discussion of (III) gives us the following properties of the parabola in addition to those already obtained (p. 174).

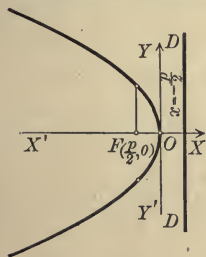

1. It passes through the origin but does not cut the axes elsewhere.

2. Values of x having the sign opposite to that of p are to be excluded (Rule, p. 73). Hence the curve lies to the *right* of YY' when p is *positive* and to the *left* when p is *negative*.

3. No values of y are to be excluded; hence the curve extends indefinitely up and down.

Theorem IV. *If the origin is the vertex and the Y-axis the axis of a parabola, then its equation is*

$$(IV) \quad x^2 = 2py.$$

The focus is the point $\left(0, \frac{p}{2}\right)$, and the equation of the directrix is $y = -\frac{p}{2}$.

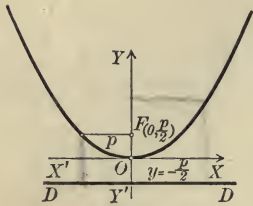

Proof. Transform (III) by rotating the axes through $-\frac{\pi}{2}$. Equations (II), p.162, give us for $\theta = -\frac{\pi}{2}$

$$x = y',$$

$$y = -x'.$$

Substituting in (III) and dropping primes, we obtain $x^2 = 2py$.

Q.E.D.

After rotating the axes the whole figure is turned through $\frac{\pi}{2}$ in the positive direction.

The parabola lies *above* or *below* the X -axis according as p is *positive* or *negative*.

Equations (III) and (IV) are called the *typical forms* of the equation of the parabola.

Equations of the forms

$$Ax^2 + Ey = 0 \text{ and } Cy^2 + Dx = 0,$$

where $A, E, C,$ and D are different from zero, may, by transposition and division, be written in one of the typical forms (III) or (IV), so that in each case the locus is a parabola.

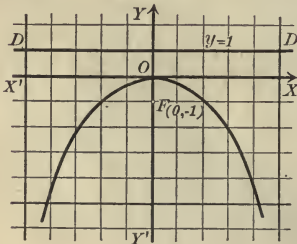
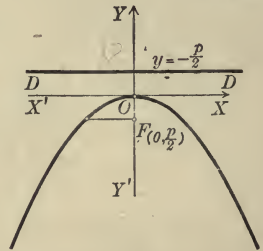

Ex. 1. Plot the locus of $x^2 + 4y = 0$ and find the focus and directrix.

Solution. The given equation may be written

$$x^2 = -4y.$$

Comparing with (IV), the locus is seen to be a parabola for which $p = -2$. Its focus is therefore the point $(0, -1)$ and its directrix the line $y = 1$.

Ex. 2. Find the equation of the parabola whose vertex is the point O' $(3, -2)$ and whose directrix is parallel to the Y -axis, if $p = 3$.

Solution. Referred to $O'X'$ and $O'Y'$ as axes, the equation of the parabola is (Theorem III)

$$(4) \quad y'^2 = 6x'$$

The equation for translating the axes from O to O' are (Theorem I, p. 160)

$$x = x' + 3, \quad y = y' - 2,$$

whence

$$(5) \quad x' = x - 3, \quad y' = y + 2.$$

Substituting in (4), we obtain as the required equation

$$(y + 2)^2 = 6(x - 3),$$

or
$$y^2 - 6x + 4y + 22 = 0.$$

Referred to $O'X'$ and $O'Y'$, the coordinates of F are (Theorem III) $(\frac{3}{2}, 0)$ and the equation of DD is $x' = -\frac{3}{2}$. By (5) we see that, referred to OX and OY , the coordinates of F are $(\frac{9}{2}, -2)$ and the equation of DD is $x = \frac{3}{2}$.

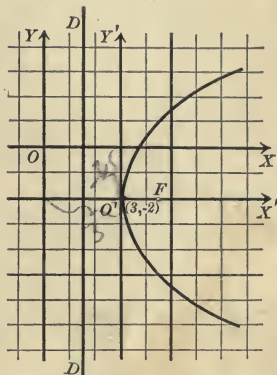

PROBLEMS

1. Plot the locus of the following equations. Draw the focus and directrix in each case.

(a) $y^2 = 4x.$

(d) $y^2 - 6x = 0.$

(b) $y^2 + 4x = 0.$

(e) $x^2 + 10y = 0.$

(c) $x^2 - 8y = 0.$

(f) $y^2 + x = 0.$

2. If the directrix is parallel to the Y -axis, find the equation of the parabola for which

(a) $p = 6$, if the vertex is $(3, 4).$

Ans. $(y - 4)^2 = 12(x - 3).$

(b) $p = -4$, if the vertex is $(2, -3).$

Ans. $(y + 3)^2 = -8(x - 2).$

(c) $p = 8$, if the vertex is $(-5, 7).$

Ans. $(y - 7)^2 = 16(x + 5).$

(d) $p = 4$, if the vertex is $(h, k).$

Ans. $(y - k)^2 = 8(x - h).$

3. The chord through the focus perpendicular to the axis is called the latus rectum. Find the length of the latus rectum of $y^2 = 2px.$ *Ans.* $2p.$

4. What is the equation of the parabola whose axis is parallel to the axis of y and whose vertex is the point (α, β) ? *Ans.* $(x - \alpha)^2 = 2p(y - \beta).$

5. Transform to polar coordinates and discuss the resulting equations (a) $y^2 = 2px,$ (b) $x^2 = 2py.$

6. Prove that the abscissas of two points on the parabola (III) are proportional to the squares of the ordinates of those points.

75. Simplification and discussion of the equation in rectangular coördinates. Central conics, $e \geq 1$. When $e \geq 1$, equation (II), p. 178, is

$$(1 - e^2)x^2 + y^2 - 2e^2px - e^2p^2 = 0.$$

To simplify (Rule, p. 165), set

$$(1) \quad x = x' + h, \quad y = y' + k,$$

which gives

$$(2) \quad (1 - e^2)x'^2 + y'^2 + 2h(1 - e^2)x' + 2ky' + (1 - e^2)h^2 + k^2 - 2e^2ph - e^2p^2 = 0.$$

Setting the coefficients of x' and y' equal to zero gives

$$2h(1 - e^2) - 2e^2p = 0, \quad 2k = 0,$$

whence

$$(3) \quad h = \frac{e^2p}{1 - e^2}, \quad k = 0.$$

Substituting in (2) and dropping primes, we obtain

$$(1 - e^2)x^2 + y^2 - \frac{e^2p^2}{1 - e^2} = 0,$$

or

$$(4) \quad \frac{x^2}{\frac{e^2p^2}{(1 - e^2)^2}} + \frac{y^2}{\frac{e^2p^2}{1 - e^2}} = 1.$$

This is obtained by transposing the constant term, dividing by it, and then dividing numerator and denominator of the first fraction by $1 - e^2$.

The ellipse, $e < 1$.

From (3) it is seen that h is *positive* when $e < 1$. Hence the new origin O lies to the *right* of the focus F .

The hyperbola, $e > 1$.

From (3) it is seen that h is *negative* when $e > 1$. Hence the new origin O lies to the *left* of the focus F .

Further, $\frac{e^2}{1 - e^2} > 1$ numerically, so $h > p$ numerically; and hence the new origin lies to the left of the directrix DD .

The locus of (4) is symmetrical with respect to YY' (Theorem V, p. 73). Hence O is the middle point of AA' . Construct in

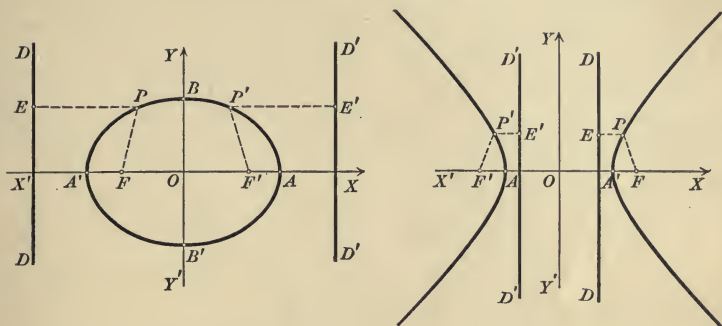

either figure F' and $D'D'$ symmetrical respectively to F and DD with respect to YY' . Then F' and $D'D'$ are a new focus and directrix.

For let P and P' be two points on the curve, symmetrical with respect to YY' . Then from the symmetry $PF = P'F'$ and $PE = P'E'$. But since, by definition, $\frac{PF}{PE} = e$, then $\frac{P'F'}{P'E'} = e$. Hence the same conic is traced by P' , using F' as focus and $D'D'$ as directrix, as is traced by P , using F as focus and DD as directrix.

Since the locus of (4) is symmetrical with respect to the origin (Theorem V, p. 73), it is called a **central conic**, and the center of symmetry is called the **center**. Hence *a central conic has two foci and two directrices*.

The coördinates of the focus F in either figure are

$$\left(-\frac{e^2 p}{1 - e^2}, 0 \right).$$

For the old coördinates of F were $(0, 0)$. Substituting in (1), the new coördinates are $x' = -h$, $y' = -k$, or, from (3), $\left(-\frac{e^2 p}{1 - e^2}, 0 \right)$.

The coördinates of F' are therefore $\left(\frac{e^2 p}{1 - e^2}, 0 \right)$.

The new equation of the directrix DD is $x = -\frac{p}{1 - e^2}$.

For from (1) and (3), $x = x' + \frac{e^2 p}{1 - e^2}$, $y = y'$. Substituting in $x = -p$ (Theorem II) and dropping primes, we obtain $x = -\frac{p}{1 - e^2}$.

Hence the equation of $D'D'$ is $x = \frac{p}{1 - e^2}$.

We thus have the

Lemma. *The equation of a central conic whose center is the origin and whose principal axis is the X-axis is*

$$(4) \quad \frac{x^2}{\frac{e^2 p^2}{(1 - e^2)^2}} + \frac{y^2}{\frac{e^2 p^2}{1 - e^2}} = 1.$$

Its foci are the points $\left(\pm \frac{e^2 p}{1 - e^2}, 0\right)$

and its directrices are the lines $x = \pm \frac{p}{1 - e^2}$.

The ellipse, $e < 1$.

For convenience set

$$(5) \quad a = \frac{ep}{1 - e^2}, \quad b^2 = \frac{e^2 p^2}{1 - e^2}, \quad c = \frac{e^2 p}{1 - e^2}.$$

a^2 and b^2 are the denominators in (4) and c is the abscissa of one focus. Since $e < 1$, $1 - e^2$ is positive; and hence a , b^2 , and c are positive.

We have at once

$$\begin{aligned} a^2 - b^2 &= \frac{e^2 p^2}{(1 - e^2)^2} - \frac{e^2 p^2}{1 - e^2} \\ &= \frac{e^4 p^2}{(1 - e^2)^2} = c^2 \end{aligned}$$

and

$$\frac{a^2}{c} = \frac{e^2 p^2}{(1 - e^2)^2} \div \frac{e^2 p}{1 - e^2} = \frac{p}{1 - e^2}.$$

Hence the directrices (Lemma) are the lines $x = \pm \frac{a^2}{c}$.

By substitution from (5) in (4) we obtain

$$\frac{x^2}{a^2} + \frac{y^2}{b^2} = 1.$$

The hyperbola, $e > 1$.

For convenience set

$$(6) \quad a = -\frac{ep}{1 - e^2}, \quad b^2 = -\frac{e^2 p^2}{1 - e^2}, \quad c = -\frac{e^2 p}{1 - e^2}.$$

a^2 and $-b^2$ are the denominators in (4) and c is the abscissa of one focus. Since $e > 1$, $1 - e^2$ is negative; and hence a , b^2 , and c are positive.

We have at once

$$\begin{aligned} a^2 + b^2 &= \frac{e^2 p^2}{(1 - e^2)^2} - \frac{e^2 p^2}{1 - e^2} \\ &= \frac{e^4 p^2}{(1 - e^2)^2} = c^2 \end{aligned}$$

and

$$\frac{a^2}{c} = \frac{e^2 p^2}{(1 - e^2)^2} \div -\frac{e^2 p}{1 - e^2} = -\frac{p}{1 - e^2}.$$

Hence the directrices (Lemma) are the lines $x = \pm \frac{a^2}{c}$.

By substitution from (6) in (4) we obtain

$$\frac{x^2}{a^2} - \frac{y^2}{b^2} = 1.$$

The ellipse, $e < 1$.

The intercepts are $x = \pm a$ and $y = \pm b$. $AA' = 2a$ is called the major axis and $BB' = 2b$ the minor axis. Since $a^2 - b^2 = c^2$ is positive, then $a > b$, and the major axis is greater than the minor axis.

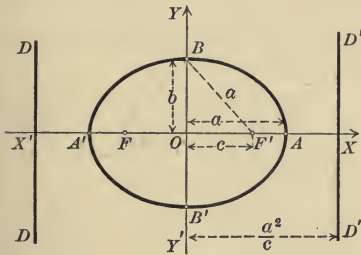

Hence we may restate the Lemma as follows.

Theorem V. *The equation of an ellipse whose center is the origin and whose foci are on the X-axis is*

$$(V) \quad \frac{x^2}{a^2} + \frac{y^2}{b^2} = 1,$$

where $2a$ is the major axis and $2b$ the minor axis. If $c^2 = a^2 - b^2$, then the foci are $(\pm c, 0)$ and the directrices are $x = \pm \frac{a^2}{c}$.

Equations (5) also enable us to express e and p , the constants of (I), p. 173, in terms of a , b , and c , the constants of (V). For

$$(7) \quad \frac{c}{a} = \frac{e^2 p}{1 - e^2} \div \frac{ep}{1 - e^2} = e$$

and

$$(9) \quad \frac{b^2}{c} = \frac{e^2 p^2}{1 - e^2} \div \frac{e^2 p}{1 - e^2} = p.$$

The hyperbola, $e > 1$.

The intercepts are $x = \pm a$, but the hyperbola does not cut the Y-axis. $AA' = 2a$ is called the transverse axis and $BB' = 2b$ the conjugate axis.

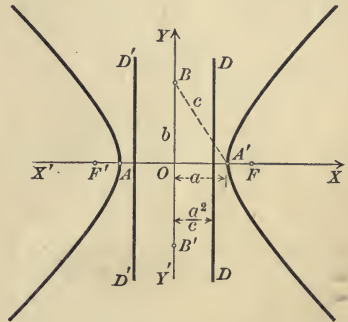

Hence we may restate the Lemma as follows.

Theorem VI. *The equation of an hyperbola whose center is the origin and whose foci are on the X-axis is*

$$(VI) \quad \frac{x^2}{a^2} - \frac{y^2}{b^2} = 1,$$

where $2a$ is the transverse axis and $2b$ the conjugate axis. If $c^2 = a^2 + b^2$, then the foci are $(\pm c, 0)$ and the directrices are $x = \pm \frac{a^2}{c}$.

Equations (6) also enable us to express e and p , the constants of (I), p. 173, in terms of a , b , and c , the constants of (VI). For

$$(8) \quad \frac{c}{a} = -\frac{e^2 p}{1 - e^2} \div -\frac{ep}{1 - e^2} = e$$

and

$$(10) \quad \frac{b^2}{c} = -\frac{e^2 p^2}{1 - e^2} \div -\frac{e^2 p}{1 - e^2} = p.$$

The ellipse, $e < 1$.

In the figure $OB = b$, $OF' = c$; and since $c^2 = a^2 - b^2$, then $BF' = a$. Hence to draw the foci, with B as a center and radius OA , describe arcs cutting XX' at F and F' . Then F and F' are the foci.

If $a = b$, then (V) becomes

$$x^2 + y^2 = a^2,$$

whose locus is a circle.

Transform (V) by rotating the axes through an angle of $-\frac{\pi}{2}$ (Theorem II, p. 162). We obtain

Theorem VII. *The equation of an ellipse whose center is the origin and whose foci are on the Y-axis is*

$$(VII) \quad \frac{x^2}{b^2} + \frac{y^2}{a^2} = 1,$$

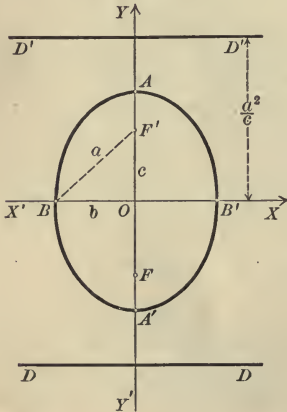

where $2a$ is the major axis and $2b$ is the minor axis. If $c^2 = a^2 - b^2$, the foci are $(0, \pm c)$ and the directrices are the lines $y = \pm \frac{a^2}{c}$.

The hyperbola, $e > 1$.

In the figure $OB = b$, $OA' = a$; and since $c^2 = a^2 + b^2$, then $BA' = c$. Hence to draw the foci, with O as a center and radius BA' , describe arcs cutting XX' at F and F' . Then F and F' are the foci.

If $a = b$, then (VI) becomes

$$x^2 - y^2 = a^2,$$

whose locus is called an equilateral hyperbola.

Transform (VI) by rotating the axes through an angle of $-\frac{\pi}{2}$ (Theorem II, p. 162). We obtain

Theorem VIII. *The equation of an hyperbola whose center is the origin and whose foci are on the Y-axis is*

$$(VIII) \quad -\frac{x^2}{b^2} + \frac{y^2}{a^2} = 1,$$

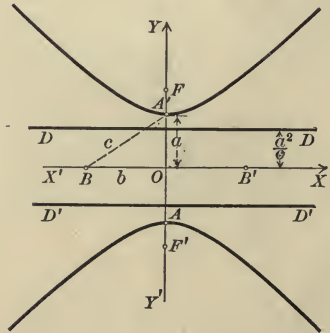

where $2a$ is the transverse axis and $2b$ is the conjugate axis. If $c^2 = a^2 + b^2$, the foci are $(0, \pm c)$ and the directrices are the lines $y = \pm \frac{a^2}{c}$.

The ellipse, $e < 1$.

The essential difference between (V) and (VII) is that in (V) the denominator of x^2 is larger than that of y^2 , while in (VII) the denominator of y^2 is the larger. (V) and (VII) are called the *typical forms* of the equation of an ellipse.

The hyperbola, $e > 1$.

The essential difference between (VI) and (VIII) is that the coefficient of y^2 is negative in (VI), while in (VIII) the coefficient of x^2 is negative. (VI) and (VIII) are called the *typical forms* of the equation of an hyperbola.

An equation of the form

$$Ax^2 + Cy^2 + F = 0,$$

where A , C , and F are all different from zero, may always be written in the form

$$(11) \quad \frac{x^2}{\alpha} + \frac{y^2}{\beta} = 1.$$

By transposing the constant term and then dividing by it, and dividing numerator and denominator of the resulting fractions by A and C respectively.

The locus of this equation will be

1. *An ellipse if α and β are both positive.* a^2 will be equal to the larger denominator and b^2 to the smaller.

2. *An hyperbola if α and β have opposite signs.* a^2 will be equal to the positive denominator and b^2 to the negative denominator.

3. If α and β are both negative, (11) will have no locus.

Ex. 1. Find the axes, foci, directrices, and eccentricity of the ellipse $4x^2 + y^2 = 16$.

Solution. Dividing by 16, we obtain

$$\frac{x^2}{4} + \frac{y^2}{16} = 1.$$

The second denominator is the larger. By comparison with (VII),

$$b^2 = 4, \quad a^2 = 16, \quad c^2 = 16 - 4 = 12.$$

$$\text{Hence} \quad b = 2, \quad a = 4, \quad c = \sqrt{12}.$$

The positive sign only is used when we extract the square root, because a , b , and c are essentially positive.

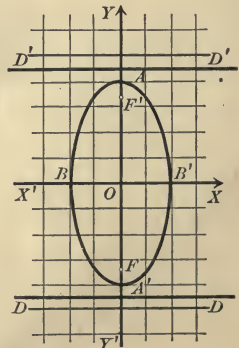

but what the deriv is C?

Hence the major axis $AA' = 8$, the minor axis $BB' = 4$, the foci F and F' are the points $(0, \pm\sqrt{12})$, and the equations of the directrices DD and $D'D'$ are $y = \pm \frac{a^2}{c} = \pm \frac{16}{\sqrt{12}} = \pm \frac{4}{3}\sqrt{12}$.

From (7) and (9), $e = \frac{\sqrt{12}}{4}$ and $p = \frac{4}{\sqrt{12}} = \frac{1}{3}\sqrt{12}$.

PROBLEMS

1. Plot the loci, directrices, and foci of the following equations and find e and p .

(a) $x^2 + 9y^2 = 81$.

(e) $9y^2 - 4x^2 = 36$.

(b) $9x^2 - 16y^2 = 144$.

(f) $x^2 - y^2 = 25$.

(c) $16x^2 + y^2 = 25$.

(g) $4x^2 + 7y^2 = 13$.

(d) $4x^2 + 9y^2 = 36$.

(h) $5x^2 - 3y^2 = 14$.

2. Find the equation of the ellipse whose center is the origin and whose foci are on the X -axis if

(a) $a = 5$, $b = 3$.

Ans. $9x^2 + 25y^2 = 225$.

(b) $a = 6$, $e = \frac{1}{3}$.

Ans. $32x^2 + 36y^2 = 1152$.

(c) $b = 4$, $c = 3$.

Ans. $16x^2 + 25y^2 = 400$.

(d) $c = 8$, $e = \frac{2}{3}$.

Ans. $5x^2 + 9y^2 = 720$.

3. Find the equation of the hyperbola whose center is the origin and whose foci are on the X -axis if

(a) $a = 3$, $b = 5$.

Ans. $25x^2 - 9y^2 = 225$.

(b) $a = 4$, $c = 5$.

Ans. $9x^2 - 16y^2 = 144$.

(c) $e = \frac{3}{2}$, $a = 5$.

Ans. $5x^2 - 4y^2 = 125$.

(d) $c = 8$, $e = 4$.

Ans. $15x^2 - y^2 = 60$.

4. Show that the latus rectum (chord through the focus perpendicular to the principal axis) of the ellipse and hyperbola is $\frac{2b^2}{a}$

5. What is the eccentricity of an equilateral hyperbola? *Ans.* $\sqrt{2}$.

6. Transform (V) and (VI) to polar coordinates and discuss the resulting equations.

7. Where are the foci and directrices of the circle?

8. What are the equations of the ellipse and hyperbola whose centers are the point (α, β) and whose principal axes are parallel to the X -axis?

Ans. $\frac{(x - \alpha)^2}{a^2} + \frac{(y - \beta)^2}{b^2} = 1$; $\frac{(x - \alpha)^2}{a^2} - \frac{(y - \beta)^2}{b^2} = 1$.

76. Conjugate hyperbolas and asymptotes. Two hyperbolas are called **conjugate hyperbolas** if the transverse and conjugate axes of one are respectively the conjugate and transverse axes of the other. They will have the same center and their principal axes (p. 173) will be perpendicular.

If the equation of an hyperbola is given in typical form, then *the equation of the conjugate hyperbola is found by changing the signs of the coefficients of x^2 and y^2 in the given equation.*

For if one equation be written in the form (VI) and the other in the form (VIII), then the positive denominator of either is numerically the same as the negative denominator of the other. Hence the transverse axis of either is the conjugate axis of the other.

Thus the loci of the equations

(1) $16x^2 - y^2 = 16$ and $-16x^2 + y^2 = 16$
are conjugate hyperbolas. They may be written

$$\frac{x^2}{1} - \frac{y^2}{16} = 1 \text{ and } -\frac{x^2}{1} + \frac{y^2}{16} = 1.$$

The foci of the first are on the X -axis, those of the second on the Y -axis. The transverse axis of the first and the conjugate axis of the second are equal to 2, while the conjugate axis of the first and the transverse axis of the second are equal to 8.

The foci of two conjugate hyperbolas are equally distant from the origin.

For c^2 (Theorems VI and VIII) equals the sum of the squares of the semi-transverse and semi-conjugate axes, and that sum is the same for two conjugate hyperbolas.

Thus in the first of the hyperbolas above $c^2 = 1 + 16$, while in the second $c^2 = 16 + 1$.

If in one of the typical forms of the equation of an hyperbola we replace the constant term by zero, then the locus of the new equation is a pair of lines (Theorem, p. 66) which are called the **asymptotes** of the hyperbola.

Thus the asymptotes of the hyperbola

(2) $b^2x^2 - a^2y^2 = a^2b^2$

are the lines

(3) $b^2x^2 - a^2y^2 = 0,$

or

(4) $bx + ay = 0$ and $bx - ay = 0.$

Both of these lines pass through the origin, and their slopes are respectively

$$(5) \quad -\frac{b}{a} \text{ and } \frac{b}{a}.$$

An important property of the asymptotes is given by

Theorem IX. *The branches of the hyperbola approach its asymptotes as they recede to infinity.*

Proof. Let $P_1(x_1, y_1)$ be a point on either branch of (2) near the first of the asymptotes (4). The distance from this line to P_1 (Fig., p. 191) is (Rule, p. 106)

$$(6) \quad d = \frac{bx_1 + ay_1}{+\sqrt{b^2 + a^2}}.$$

Since P_1 lies on (2), $b^2x_1^2 - a^2y_1^2 = a^2b^2$.

$$\text{Factoring,} \quad bx_1 + ay_1 = \frac{a^2b^2}{bx_1 - ay_1}.$$

$$\text{Substituting in (6),} \quad d = \frac{a^2b^2}{+\sqrt{b^2 + a^2}(bx_1 - ay_1)}.$$

As P_1 recedes to infinity, x_1 and y_1 become infinite and d approaches zero.

For bx_1 and ay_1 cannot cancel, since x_1 and y_1 have opposite signs in the second and fourth quadrants.

Hence the curve approaches closer and closer to its asymptotes.

Q. E. D.

Two conjugate hyperbolas have the same asymptotes.

For if we replace the constant term in both equations by zero, the resulting equations differ only in form and hence have the same loci.

Thus the asymptotes of the conjugate hyperbolas (1) are respectively the loci of

$$16x^2 - y^2 = 0 \text{ and } -16x^2 + y^2 = 0,$$

which are the same.

An hyperbola may be drawn with fair accuracy by the following

Construction. Lay off $OA = OA' = a$ on the axis on which the foci lie, and $OB = OB' = b$ on the other axis. Draw lines through A, A', B, B' parallel to the axes, forming a rectangle.* Draw the

* An ellipse may be drawn with fair accuracy by inscribing it in such a rectangle.

diagonals of the rectangle and the circumscribed circle. Draw the branches of the hyperbola tangent to the sides of the rectangle at A and A' and approaching nearer and nearer to the diagonals. The conjugate hyperbola may be drawn tangent to the sides of the rectangle at B and B' and approaching the diagonals. The foci of both are the points in which the circle cuts the axes.

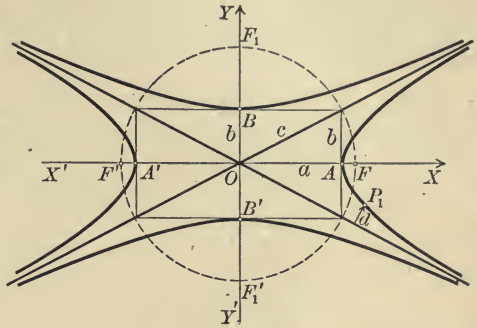

The diagonals will be the asymptotes, because two of the vertices of the rectangle ($\pm a, \pm b$) will lie on each asymptote (4). Half the diagonal will equal c , the distance from the origin to the foci, because $c^2 = a^2 + b^2$.

77. The equilateral hyperbola referred to its asymptotes. The equation of the equilateral hyperbola (p. 186) is

(1)
$$x^2 - y^2 = a^2.$$

Its asymptotes are the lines

$$x - y = 0 \text{ and } x + y = 0.$$

These lines are perpendicular (Corollary III, p. 87), and hence they may be used as coördinate axes.

Theorem X. *The equation of an equilateral hyperbola referred to its asymptotes is*

(X)
$$2xy = a^2.$$

Proof. The axes must be rotated through $-\frac{\pi}{4}$ to coincide with the asymptotes.

Hence we substitute (Theorem II, p. 162)

$$x = \frac{x' + y'}{\sqrt{2}}, \quad y = \frac{-x' + y'}{\sqrt{2}}$$

in (1). This gives

$$\frac{(x' + y')^2}{2} - \frac{(-x' + y')^2}{2} = a^2.$$

Or, reducing and dropping primes,

$$2xy = a^2.$$

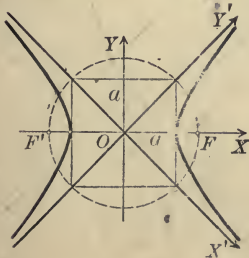

78. Focal property of central conics. A line joining a point on a conic to a focus is called a focal radius. Two focal radii, one to each focus, may evidently be drawn from any point on a central conic.

Theorem XI. *The sum of the focal radii from any point on an ellipse is equal to the major axis $2a$.*

Theorem XII. *The difference of the focal radii from any point on an hyperbola is equal to the transverse axis $2a$.*

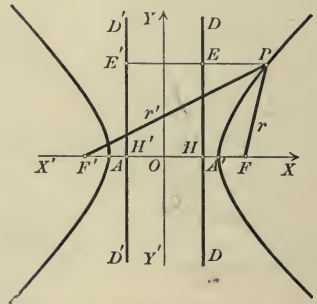
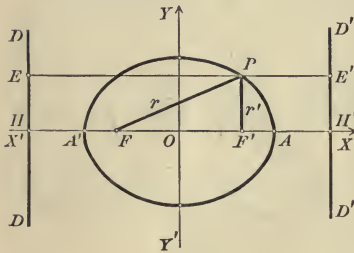

Proof. Let P be any point on the ellipse. By definition (p. 173),

$$r = e \cdot PE, \quad r' = e \cdot PE'.$$

$$\text{Hence } r + r' = e(PE + PE') = e \cdot HH'.$$

$$\text{From (7), p. 185, } e = \frac{c}{a},$$

and from the equations of the directrices (Theorem V),

$$HH' = 2 \frac{a^2}{c}.$$

$$\text{Hence } r + r' = \frac{c}{a} \cdot 2 \frac{a^2}{c} = 2a.$$

Q. E. D.

Proof. Let P be any point on the hyperbola. By definition (p. 173),

$$r = e \cdot PE, \quad r' = e \cdot PE'.$$

$$\text{Hence } r' - r = e(PE' - PE) = e \cdot HH'.$$

$$\text{From (8), p. 185, } e = \frac{c}{a},$$

and from the equations of the directrices (Theorem VI),

$$HH' = 2 \frac{a^2}{c}.$$

$$\text{Hence } r' - r = \frac{c}{a} \cdot 2 \frac{a^2}{c} = 2a.$$

Q. E. D.

79. Mechanical construction of conics. Theorems XI and XII afford simple methods of drawing ellipses and hyperbolas. Place two tacks in the drawing board at the foci F and F' and wind a string about them as indicated.

If the string be held fast at A , and a pencil be placed in the loop FPF' and be moved so as to keep the string taut, then $PF + PF'$ is constant and P describes an ellipse. If the major axis is to be $2a$, then the length of the loop FPF' must be $2a$.

If the pencil be tied to the string at P , and both strings be pulled in or let out at A at the same time, then $PF' - PF$ will be constant and P will describe an hyperbola. If the transverse axis is to be $2a$, the strings must be adjusted at the start so that the difference between PF' and PF equals $2a$.

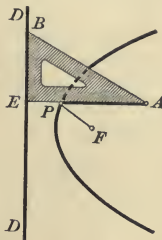
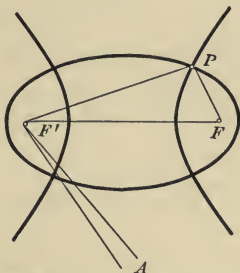

To describe a parabola, place a right triangle with one leg EB on the directrix DD . Fasten one end of a string whose length is AE at the focus F , and the other end to the triangle at A . With a pencil at P keep the string taut. Then $PF = PE$; and as the triangle is moved along DD the point P will describe a parabola.

PROBLEMS

1. Find the equations of the asymptotes and hyperbolas conjugate to the following hyperbolas, and plot.

(a) $4x^2 - y^2 = 36$.

(c) $16x^2 - y^2 + 64 = 0$.

(b) $9x^2 - 25y^2 = 100$.

(d) $8x^2 - 16y^2 + 25 = 0$.

2. Prove Theorem IX for the asymptote which passes through the first and third quadrants.

3. If e and e' are the eccentricities of two conjugate hyperbolas, then $\frac{1}{e^2} + \frac{1}{e'^2} = 1$.

4. The distance from an asymptote of an hyperbola to its foci is numerically equal to b .

5. The distance from a line through a focus of an hyperbola, perpendicular to an asymptote, to the center is numerically equal to a .

6. The product of the distances from the asymptotes to any point on the hyperbola is constant.

7. The focal radius of a point $P_1(x_1, y_1)$ on the parabola $y^2 = 2px$ is $\frac{p}{2} + x_1$.

8. The focal radii of a point $P_1(x_1, y_1)$ on the ellipse $b^2x^2 + a^2y^2 = a^2b^2$ are $r = a - ex_1$ and $r' = a + ex_1$.

9. The focal radii of a point on the hyperbola $b^2x^2 - a^2y^2 = a^2b^2$ are $r = ex_1 - a$ and $r' = ex_1 + a$ when P_1 is on the right-hand branch, or $r = -ex_1 - a$ and $r' = -ex_1 + a$ when P_1 is on the left-hand branch.

10. The distance from a point on an equilateral hyperbola to the center is a mean proportional between the focal radii of the point.

11. The eccentricity of an hyperbola equals the secant of the inclination of one asymptote.

80. Types of loci of equations of the second degree. All of the equations of the conic sections that we have considered are of the second degree. If the axes be moved in any manner, the equation will still be of the second degree (Theorem IV, p. 164), although its form may be altered considerably. We have now to consider the different possible forms of loci of equations of the second degree.

By Theorem VI, p. 169, the term in xy may be removed by rotating the axes. Hence we only need to consider an equation of the form

$$(1) \quad Ax^2 + Cy^2 + Dx + Ey + F = 0.$$

It is necessary to distinguish two cases.

CASE I. Neither A nor C is zero.

CASE II. Either A or C is zero.

A and C cannot both be zero, as then (1) would not be of the second degree.

Case I

When neither A nor C is zero, then $\Delta = B^2 - 4AC$ is not zero, and hence (Theorem VII, p. 170) we can remove the terms in x and y by translating the axes. Then (1) becomes (Corollary I, p. 171)

$$(2) \quad Ax'^2 + Cy'^2 + F' = 0.$$

We distinguish two types of loci according as A and C have the same or different signs.

Elliptic type, A and C have the same sign.

1. $F' \neq 0$.* Then (2) may be

written
$$\frac{x^2}{\alpha} + \frac{y^2}{\beta} = 1,$$

where $\alpha = -\frac{F'}{A}, \beta = -\frac{F'}{C}.$

Hence, if the sign of F' is different from that of A and C , the locus is an *ellipse*; but if the sign of F' is the same as that of A and C , there is *no locus*.

2. $F' = 0$. The locus is a *point*. It may be regarded as an ellipse whose axes are zero and it is called a *degenerate ellipse*.

Hyperbolic type, A and C have different signs.

1. $F' \neq 0$.* Then (2) may be

written
$$\frac{x^2}{\alpha} + \frac{y^2}{\beta} = 1,$$

where $\alpha = -\frac{F'}{A}, \beta = -\frac{F'}{C}.$

Hence the locus is an *hyperbola* whose foci are on the Y -axis if the signs of F' and A are the same, or on the X -axis if the signs of F' and C are the same.

2. $F' = 0$. The locus is a pair of *intersecting lines*. It may be regarded as an hyperbola whose axes are zero and it is called a *degenerate hyperbola*.

Case II

When either A or C is zero the locus is said to belong to the **parabolic type**. We can always suppose $A = 0$ and $C \neq 0$, so that (1) becomes

(3)
$$Cy^2 + Dx + Ey + F = 0.$$

For if $A \neq 0$ and $C = 0$, (1) becomes $Ax^2 + Dx + Ey + F = 0$. Rotate the axes (Theorem II, p. 162) through $\frac{\pi}{2}$ by setting $x = -y', y = x'$. This equation becomes $Ay'^2 + Ex' - Dy' + F = 0$, which is of the form (3).

By translating the axes (3) may be reduced to one of the forms

(4)
$$Cy^2 + Dx = 0$$
 or

(5)
$$Cy^2 + F' = 0.$$

For substitute in (3), $x = x' + h, y = y' + k.$

This gives

(6)
$$Cy'^2 + Dx' + 2Ck \left| \begin{array}{l} y' + Ck^2 \\ + Dh \\ + Ek \\ + F' \end{array} \right| = 0.$$

If we determine h and k from

$$2Ck + E = 0, \quad Ck^2 + Dh + Ek + F' = 0,$$

then (6) reduces to (4). But if $D = 0$, we cannot solve the last equation for h , so that we cannot always remove the constant term. In this case (6) reduces to (5).

* Read " F' not equal to zero" or " F' different from zero."

Comparing (4) with (III), p. 179, the locus is seen to be a *parabola*. The locus of (5) is the pair of *parallel lines* $y = \pm \sqrt{-\frac{F'}{C}}$ when F' and C have different signs, or the *single line* $y = 0$ when $F' = 0$. If F' and C have the same sign, there is *no locus*. When the locus of an equation of the second degree is a pair of parallel lines or a single line it is called a **degenerate parabola**.

We have thus proved

Theorem XIII. *The locus of an equation of the second degree is a conic, a point, or a pair of straight lines, which may be coincident. By moving the axes its equation may be reduced to one of the three forms*

$$Ax^2 + Cy^2 + F^* = 0, \quad Cy^2 + Dx = 0, \quad Cy^2 + F^* = 0,$$

where A , C , and D are different from zero.

Corollary. *The locus of an equation in which the term in xy is lacking,*

$$Ax^2 + Cy^2 + Dx + Ey + F = 0,$$

will belong to

the parabolic type if $A = 0$ or $C = 0$,

the elliptic type if A and C have the same sign,

the hyperbolic type if A and C have different signs.

PROBLEMS

1. To what point is the origin moved to transform (1) into (2)?

$$\text{Ans. } \left(-\frac{D}{2A}, -\frac{E}{2C} \right).$$

2. To what point is the origin moved to transform (3) into (4)? into (5)?

$$\text{Ans. } \left(\frac{E^2 - 4CF}{4CD}, -\frac{E}{2C} \right), \quad \left(0, -\frac{E}{2C} \right).$$

3. Simplify $Ax^2 + Dx + Ey + F = 0$ by translating the axes (a) if $E \neq 0$, (b) if $E = 0$, and find the point to which the origin is moved.

$$\text{Ans. (a) } Ax^2 + Ey = 0, \quad \left(-\frac{D}{2A}, \frac{D^2 - 4AF}{4AE} \right);$$

$$\text{(b) } Ax^2 + F = 0, \quad \left(-\frac{D}{2A}, 0 \right).$$

* In describing the final form of the equation it is unnecessary to indicate by primes what terms are different from those in (1).

4. To what types do the loci of the following equations belong?

(a) $4x^2 + y^2 - 13x + 7y - 1 = 0.$

(e) $x^2 + 7y^2 - 8x + 1 = 0.$

(b) $y^2 + 3x - 4y + 9 = 0.$

(f) $x^2 + y^2 - 6x + 8y = 0.$

(c) $121x^2 - 44y^2 + 68x - 4 = 0.$

(g) $3x^2 - 4y^2 - 6y + 9 = 0.$

(d) $x^2 + 4y - 3 = 0.$

(h) $x^2 - 8x + 9y - 11 = 0.$

(i) The equations in problem 1, p. 172, which do not contain the xy -term.

81. Construction of the locus of an equation of the second degree. To remove the xy -term from

$$(1) \quad Ax^2 + Bxy + Cy^2 + Dx + Ey + F = 0$$

it is necessary to rotate the axes through an angle θ such that (Theorem VI, p. 169)

$$(2) \quad \tan 2\theta = \frac{B}{A - C},$$

while in the formulas for rotating the axes [(II), p. 162] we need $\sin \theta$ and $\cos \theta$. By 1 and 3, p. 19, we have

$$(3) \quad \cos 2\theta = \pm \frac{1}{\sqrt{1 + \tan^2 2\theta}}.$$

From (2) we can choose 2θ in the first or second quadrant so the *sign* in (3) must be the same as in (2). θ will then be acute; and from 15, p. 20, we have

$$(4) \quad \sin \theta = + \sqrt{\frac{1 - \cos 2\theta}{2}}, \quad \cos \theta = + \sqrt{\frac{1 + \cos 2\theta}{2}}.$$

In simplifying a numerical equation of the form (1) the computation is simplified, if $\Delta = B^2 - 4AC \neq 0$, by first removing the terms in x and y (Theorem VII, p. 170) and then the xy -term.

Hence we have the

Rule to construct the locus of a numerical equation of the second degree.

First step. Compute $\Delta = B^2 - 4AC$.

Second step. Simplify the equation by

(a) translating and then rotating the axes if $\Delta \neq 0$;

(b) rotating and then translating the axes if $\Delta = 0$.

Third step. Determine the nature of the locus by inspection of the equation (§ 80, p. 194).

Fourth step. Plot all of the axes used and the locus.

In the second step the equations for rotating the axes are found from equations (2), (3), (4), and (II), p. 162. But if the xy -term is lacking, it is not necessary to rotate the axes. The equations for translating the axes are found by the Rule on p. 165.

Ex. 1. Construct and discuss the locus of

$$x^2 + 4xy + 4y^2 + 12x - 6y = 0.$$

Solution. First step. Here $\Delta = 4^2 - 4 \cdot 1 \cdot 4 = 0$.

Second step. Hence we rotate the axes through an angle θ such that, by (2),

$$\tan 2\theta = \frac{4}{1-4} = -\frac{4}{3}.$$

Then by (3), $\cos 2\theta = -\frac{3}{5}$,

and by (4), $\sin \theta = \frac{2}{\sqrt{5}}$ and $\cos \theta = \frac{1}{\sqrt{5}}$.

The equations for rotating the axes [(II), p. 162] become

$$(1) \quad x = \frac{x' - 2y'}{\sqrt{5}}, \quad y = \frac{2x' + y'}{\sqrt{5}}.$$

Substituting in the given equation,* we obtain

$$x'^2 - \frac{6}{\sqrt{5}}y' = 0.$$

It is not necessary to translate the axes.

Third step. This equation may be written

$$x'^2 = \frac{6}{\sqrt{5}}y'.$$

Hence the locus is a parabola for which $p = \frac{3}{\sqrt{5}}$, and whose focus is on the Y' -axis.

* When $\Delta = 0$ the terms of the second degree form a perfect square. The work of substitution is simplified if the given equation is first written in the form

$$(x + 2y)^2 + 12x - 6y = 0.$$

It will be shown in Chapter XII that when $\Delta = 0$ the locus is always of the parabolic type.

Fourth step. The figure shows both sets of axes,* the parabola, its focus and directrix.

In the new coördinates the focus is the point $(0, \frac{3}{2\sqrt{5}})$ and the directrix is the line $y' = -\frac{3}{2\sqrt{5}}$ (Theorem IV, p. 179). The old coördinates of the focus may be found by substituting the new coördinates for x' and y' in (1), and the equation of the directrix in the old coördinates may be found by solving (1) for y' and substituting in the equation given above.

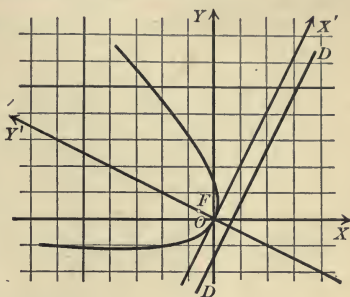

Ex. 2. Construct the locus of

$$5x^2 + 6xy + 5y^2 + 22x - 6y + 21 = 0.$$

Solution. First step. $\Delta = 6^2 - 4 \cdot 5 \cdot 5 \neq 0$.

Second step. Hence we translate the axes first. It is found that the equations for translating the axes are

$$x = x' - 4, \quad y = y' + 3,$$

and that the transformed equation is

$$5x'^2 + 6x'y' + 5y'^2 = 32.$$

From (2) it is seen that the axes must be rotated through $\frac{\pi}{4}$. Hence we set

$$x' = \frac{x'' - y''}{\sqrt{2}}, \quad y' = \frac{x'' + y''}{\sqrt{2}};$$

and the final equation is

$$4x''^2 + y''^2 = 16.$$

Third step. The simplified equation may be written

$$\frac{x''^2}{4} + \frac{y''^2}{16} = 1.$$

Hence the locus is an ellipse whose major axis is 8, whose minor axis is 4, and whose foci are on the Y'' -axis.

Fourth step. The figure shows the three sets of axes and the ellipse.

*The inclination of OX' is θ , and hence its slope, $\tan \theta$, may be obtained from (4). In this example $\tan \theta = \frac{\sin \theta}{\cos \theta} = \frac{2}{\sqrt{5}} \div \frac{1}{\sqrt{5}} = 2$, and the X' -axis may be constructed by the method given in the footnote, p. 35.

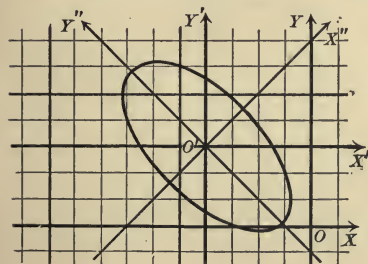

PROBLEMS

1. Simplify the following equations and construct their loci, foci, and directrices.

- (a) $3x^2 - 4xy + 8x - 1 = 0$. *Ans.* $x''^2 - 4y''^2 + 1 = 0$.
- (b) $4x^2 + 4xy + y^2 + 8x - 16y = 0$. *Ans.* $5x''^2 - 8\sqrt{5}y'' = 0$.
- (c) $41x^2 - 24xy + 34y^2 + 25 = 0$. *Ans.* $x''^2 + 2y''^2 + 1 = 0$.
- (d) $17x^2 - 12xy + 8y^2 - 68x + 24y - 12 = 0$.
Ans. $x''^2 + 4y''^2 - 16 = 0$.
- (e) $y^2 + 6x - 6y + 21 = 0$. *Ans.* $y''^2 + 6x' = 0$.
- (f) $x^2 - 6xy + 9y^2 + 4x - 12y + 4 = 0$. *Ans.* $y''^2 = 0$.
- (g) $12xy - 5y^2 + 48y - 36 = 0$. *Ans.* $4x''^2 - 9y''^2 = 36$.
- (h) $4x^2 - 12xy + 9y^2 + 2x - 3y - 12 = 0$.
Ans. $52y''^2 - 49 = 0$.
- (i) $14x^2 - 4xy + 11y^2 - 88x + 34y + 149 = 0$.
Ans. $2x''^2 + 3y''^2 = 0$.
- (j) $12x^2 + 8xy + 18y^2 + 48x + 16y + 43 = 0$.
Ans. $4x^2 + 2y^2 = 1$.
- (k) $9x^2 + 24xy + 16y^2 - 36x - 48y + 61 = 0$.
Ans. $x''^2 + 1 = 0$.
- (l) $7x^2 + 50xy + 7y^2 = 50$. *Ans.* $16x''^2 - 9y''^2 = 25$.
- (m) $x^2 + 3xy - 3y^2 + 6x + 9y + 9 = 0$. *Ans.* $3x''^2 - 7y''^2 = 0$.
- (n) $16x^2 - 24xy + 9y^2 - 60x - 80y + 400 = 0$.
Ans. $y''^2 - 4x'' = 0$.
- (o) $95x^2 + 56xy - 10y^2 - 56x + 20y + 194 = 0$.
Ans. $6x''^2 - y''^2 + 12 = 0$.
- (p) $5x^2 - 5xy - 7y^2 - 165x + 1320 = 0$. *Ans.* $15x''^2 - 11y''^2 - 330 = 0$.

82. Systems of conics. The purpose of this section is to illustrate by examples and problems the relations between conics and degenerate conics and between conics of different types.

A system of conics of the same type shows how the degenerate conics appear as limiting forms, while a system of conics of different types shows that the parabolic type is intermediate between the elliptic and hyperbolic types.

Ex. 1. Discuss the system of conics represented by $x^2 + 4y^2 = k$.

Solution. Since the coefficients of x^2 and y^2 have the same sign, the locus belongs to the elliptic type (Corollary, p. 196). When k is positive the locus is an ellipse; when $k = 0$ the locus is the origin, — a degenerate ellipse; and when k is negative there is no locus.

In the figure the locus is plotted for $k = 100, 64, 36, 16, 4, 1, 0$. It is seen that as k approaches zero the ellipses become smaller and finally degenerate into a point. As soon as k becomes negative there is no locus. Hence the

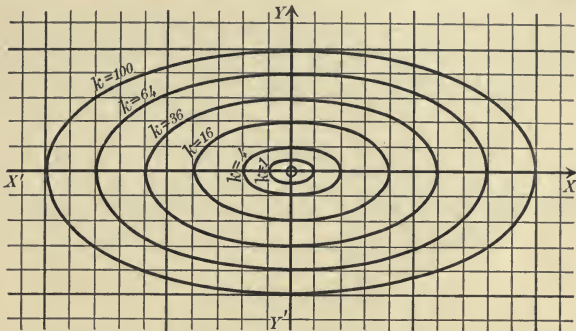

point is a *limiting case* between the cases when the locus is an ellipse and when there is no locus.

Ex. 2. Discuss the system of conics represented by $4x^2 - 16y^2 = k$.

Solution. Since the coefficients of x^2 and y^2 have opposite signs, the locus

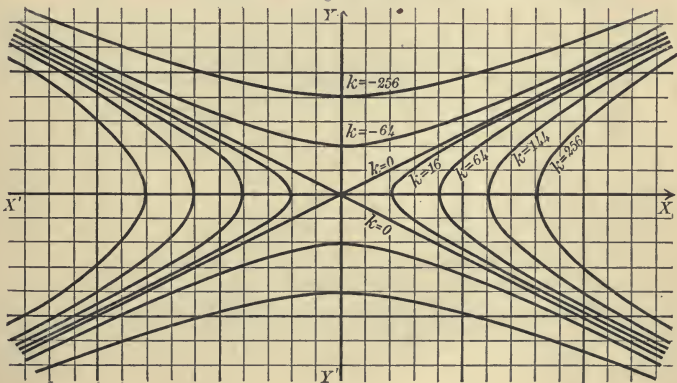

belongs to the hyperbolic type. The hyperbolas will all have the same asymptotes (p. 189), namely, the lines $x \pm 2y = 0$. The given equation may be written

$$\frac{x^2}{\frac{k}{4}} - \frac{y^2}{\frac{k}{16}} = 1.$$

The locus is an hyperbola whose foci are on the X -axis when k is positive and

on the Y -axis when k is negative. For $k = 0$ the given equation shows that the locus is the pair of asymptotes.

In the figure the locus is plotted for $k = 256, 144, 64, 16, 0, -64, -256$. It is seen that as k approaches zero, whether it is positive or negative, the hyperbolas become more pointed and lie closer to the asymptotes and finally degenerate into the asymptotes. Hence a pair of intersecting lines is a *limiting case* between the cases when the hyperbolas have their foci on the X -axis and on the Y -axis.

Ex. 3. Discuss the system of conics represented by $y^2 = 2kx + 16$.

Solution. As only one term of the second degree is present, the locus belongs to the parabolic type (Corollary, p. 196). The given equation may be simplified (Rule, p. 165) by translating the axes to the new origin $(-\frac{8}{k}, 0)$. We thus obtain

$$y'^2 = 2kx'.$$

The locus is therefore a parabola whose vertex is $(-\frac{8}{k}, 0)$ and for which $p = k$. It will be turned to the right when k is positive, and to the left when k is negative. But if $k = 0$, the locus is the degenerate parabola $y = \pm 4$.

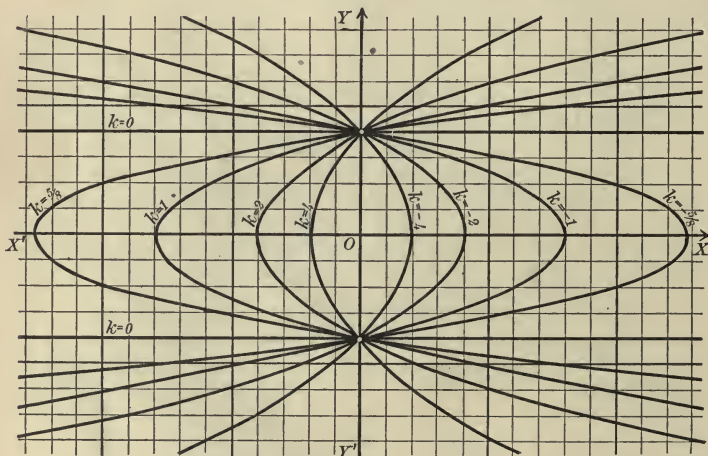

In the figure the locus is plotted for $k = \pm 4, \pm 2, \pm 1, \pm \frac{5}{8}, 0$. It is seen that as k approaches zero, whether it is positive or negative, the vertex recedes from the origin and the parabola lies closer to the lines $y = \pm 4$ and finally degenerates into these lines. The degenerate parabola consisting of two parallel lines appears as a *limiting case* between the cases when the parabolas are turned to the right and to the left.

Ex. 4. Discuss the system represented by $\frac{x^2}{25-k} + \frac{y^2}{9-k} = 1$.

Solution. When $k < 9$ the locus is an ellipse whose foci are $(\pm c, 0)$ where $c^2 = (25 - k) - (9 - k) = 16$ (Theorem V, p. 185). When $9 < k < 25$ the locus is an hyperbola whose foci are $(\pm c, 0)$, where $c^2 = (25 - k) - (9 - k) = 16$ (Theorem VI, p. 185). When $k > 25$ there is no locus. Since the ellipses and hyperbolas have the same foci, $(\pm 4, 0)$, they are called **confocal**.

Clearing of fractions, we obtain

$$(9 - k)x^2 + (25 - k)y^2 = (9 - k)(25 - k).$$

Hence when $k = 9$ or 25 the locus is a degenerate parabola $y^2 = 0$ or $x^2 = 0$.

In the figure the locus is plotted for $k = -56, -24, 0, 7, 9, 11, 16, 21, 24, 25$. As k increases and approaches 9 the ellipses flatten out and finally

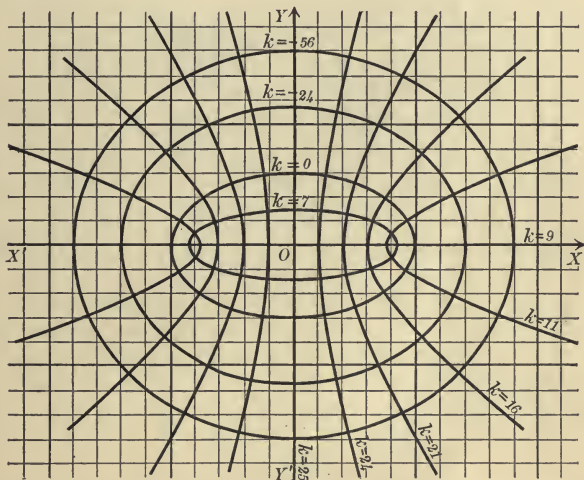

degenerate into the X -axis, and as k decreases and approaches 9 the hyperbolas flatten out and degenerate into the X -axis. Hence the locus of the parabolic type, $y^2 = 0$, appears as a limiting case between the ellipses and hyperbolas. As k increases and approaches 25, the two branches of the hyperbolas lie closer to the Y -axis, and in the limit they coincide with the Y -axis.

Ex. 5. Plot and discuss the locus of $kx^2 + 2y^2 - 8x = 0$.

Solution. If $k = 0$, the locus is a parabola. If k is not zero, the locus is an ellipse or hyperbola according as k is positive or negative. The locus passes through the origin for all values of k .

Simplifying by translating the axes (Rule, p. 165), it is found that if the origin is $(\frac{2}{k}, 0)$ the equation becomes

$$\frac{x'^2}{\frac{4}{k^2}} + \frac{y'^2}{\frac{2}{k}} = 1.$$

From this the axes may be determined and the locus sketched.

In the figure the locus is plotted for $k = 1, \frac{2}{3}, \frac{1}{2}, 0, -1, -\frac{1}{2}$. If k is positive and approaches zero, the ellipses become longer and lie closer to the

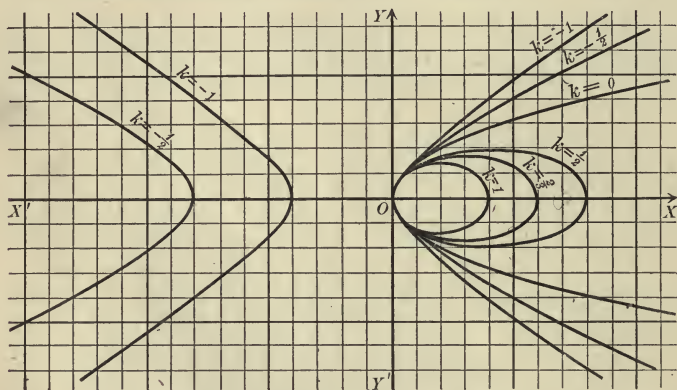

parabola. If k is negative and approaches zero, the right-hand branches of the hyperbolas lie closer to the parabola and the left-hand branches recede from the origin. This shows that *the parabola is a limiting form between the ellipse and hyperbola.*

How does the locus behave if k approaches $+\infty$ or $-\infty$?

PROBLEMS

1. Plot on separate sheets the foci and directrices of the conics plotted in examples 1, 2, and 3. Where are the foci and directrices of the degenerate conic in each system? Verify the results analytically.

2. Plot the following systems of conics and show that the conics of each system belong to the same type. Draw enough conics so that the degenerate conics of the system appear as limiting cases.

(a) $\frac{x^2}{16} + \frac{y^2}{9} = k.$

(c) $\frac{x^2}{16} - \frac{y^2}{9} = k.$

(b) $y^2 = 2kx.$

(d) $x^2 = 2ky - 6.$

3. Problem 1 for the systems in problem 2.

4. Plot the system $\frac{x^2}{k} + \frac{y^2}{16} = 1$ for positive values of k . What is the locus if $k = 16$? Show how the foci and directrices behave as k increases or decreases and approaches 16. Where are the foci and directrices of a circle?

5. Plot the system in problem 4 for positive and negative values of k . Show how the conics change as k approaches zero when it is positive and negative.

6. Plot the following systems of conics and show that all of the conics of each system are confocal. Discuss degenerate cases and show that two conics of each system pass through every point in the plane.

(a) $\frac{x^2}{16-k} + \frac{y^2}{36-k} = 1.$

(c) $\frac{x^2}{64-k} + \frac{y^2}{16-k} = 1.$

(b) $y^2 = 2kx + k^2.$

(d) $x^2 = 2ky + k^2.$

7. Plot and discuss the systems

(a) $16(x-k)^2 + 9y^2 = 144.$

(c) $(y-k)^2 = 4x.$

(b) $xy = k.$

(d) $4(x-k)^2 - 9(y-k)^2 = 36.$

8. Plot the following systems and discuss the locus as k approaches zero and infinity. Show how the foci and directrices behave in each case.

(a) $\frac{(x-k)^2}{k^2} + \frac{y^2}{36} = 1.$

(b) $\frac{(x-k)^2}{k^2} - \frac{y^2}{36} = 1.$

9. Show that all of the conics of the following systems pass through the points of intersection of the conics obtained by setting the parentheses equal to zero. Plot the systems and discuss the loci for the values of k indicated.

(a) $(y^2 - 4x) + k(y^2 + 4x) = 0, k = +1, -1.$

(b) $(x^2 + y^2 - 16) + k(x^2 - y^2 - 4) = 0, k = +1, -1, -4.$

(c) $(x^2 + y^2 - 16) + k(x^2 - y^2 - 16) = 0, k = +1, -1.$

(d) $(x^2 + 16y^2 - 64) + k(x^2 - 4y^2 - 36) = 0, k = -1, 4, -\frac{1}{9}.$

(e) $x^2 + 4y + k(x^2 - 4y + 16) = 0, k = +1, -1.$

MISCELLANEOUS PROBLEMS

1. Construct the loci of the following equations, their foci and directrices.

(a) $9x^2 + 24xy + 16y^2 - 50x + 80y - 275 = 0.$

(b) $56x^2 - 64xy + 109y^2 - 176x + 282y - 896 = 0.$

(c) $5x^2 - 12xy + 6x - 36y - 63 = 0.$

2. Find the value of p if $y^2 = 2px$ passes through the point $(3, -1)$.

3. Find the values of a and b if $\frac{x^2}{a^2} + \frac{y^2}{b^2} = 1$ passes through the points $(3, -6)$ and $(4, 8)$.

4. Find the equation of the locus of a point P if the sum of its distances from the points $(c, 0)$ and $(-c, 0)$ is $2a$.

5. Find the equation of the locus of a point P if the difference of its distances from the points $(c, 0)$ and $(-c, 0)$ is $2a$.

6. Find the equation of the locus of a point if its distances from the line $x = -\frac{p}{2}$ and the point $(\frac{p}{2}, 0)$ are equal.

7. Show that a conic or degenerate conic may be found which satisfies five conditions, and formulate a rule by which to find its equation.

Hint. Compare p. 93 and p. 133.

8. Find the equation of the conics which satisfy the following conditions.

(a) Passing through $(0, 0)$, $(1, 2)$, $(1, -2)$, $(4, 4)$, $(4, -4)$.

(b) Passing through $(0, 0)$, $(0, 1)$, $(2, 4)$, $(0, 4)$, $(-1, -2)$.

(c) Passing through $(3, 7)$, $(4, 6)$, $(5, 3)$ if $A = B$ and $C = 0$.

(d) Passing through $(1, 2)$, $(3, 4)$, $(4, 2)$, $(2, -1)$, $(4, 2)$.

(e) Passing through $(0, 0)$, $(0, 1)$, $(1, 0)$, $(6, 6)$, $(5, 6)$.

(f) Passing through $(0, 0)$, $(2, 0)$, $(-3, 2)$, $(5, 2)$ with its axes parallel to the coördinate axes.

9. What is the nature of a conic which passes through five points, of which three or four are on a straight line?

The circle whose radius is a and whose center is the center of a central conic is called the **auxiliary circle**.

10. The ordinates of points on an ellipse and the auxiliary circle which have the same abscissas are in the ratio of $b : a$.

11. The area of an ellipse is πab .

Hint. Divide the major axis into equal parts. With these as bases inscribe rectangles in the ellipse and auxiliary circle. Apply problem 10 and increase the number of rectangles indefinitely.

12. The auxiliary circle of an hyperbola passes through the intersections of the directrices and asymptotes.

13. Show that the locus of $xy + Dx + Ey + F = 0$ is either an equilateral hyperbola whose asymptotes are parallel to the coördinate axes or a pair of perpendicular lines.

14. Discuss the form of the locus of $x^2 - y^2 + Dx + Ey + F = 0$.

CHAPTER IX

TANGENTS AND NORMALS

83. The slope of the tangent. Let P_1 be a fixed point on a curve C and let P_2 be a second point on C near P_1 . Let P_2 approach P_1 by *moving along* C . Then the limiting position P_1T of the secant through P_1 and P_2 is called the **tangent** to C at P_1 .

It is evident that the slope of P_1T is the limit of the slope of P_1P_2 . The coördinates of P_2 may be written $(x_1 + h, y_1 + k)$,

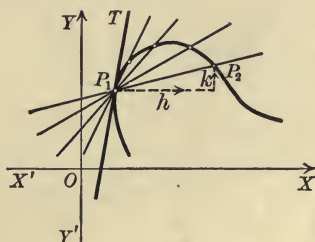

where h and k will be positive or negative numbers according to the relative positions of P_1 and P_2 . The slope of the secant through P_1 and P_2 is therefore (Theorem V, p. 35)

$$(1) \quad \frac{y_1 - (y_1 + k)}{x_1 - (x_1 + h)} = \frac{k}{h}.$$

As P_2 approaches P_1 both h and k approach zero, and hence $\frac{k}{h}$ approaches $\frac{0}{0}$, which is indeterminate. The actual value of the limit of $\frac{k}{h}$ may be found in any case from the conditions that P_1 and P_2 lie on C (Corollary, p. 53), as in the example following.

Ex. 1. Find the slope of the tangent to the curve $C: 8y' = x^3$ at any point $P_1(x_1, y_1)$ on C .

Solution. Let $P_1(x_1, y_1)$ and $P_2(x_1 + h, y_1 + k)$ be two points on C .

Then (Corollary, p. 53)

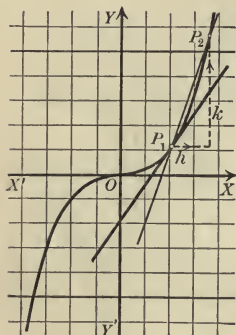

$$(2) \quad 8y_1 = x_1^3$$

$$\text{and} \quad 8(y_1 + k) = (x_1 + h)^3,$$

or

$$(3) \quad 8y_1 + 8k = x_1^3 + 3x_1^2h + 3x_1h^2 + h^3.$$

Subtracting (2) from (3), we obtain

$$8k = 3x_1^2h + 3x_1h^2 + h^3.$$

Factoring, $8k = h(3x_1^2 + 3x_1h + h^2)$;

$$\text{and hence} \quad \frac{k}{h} = \frac{3x_1^2 + 3x_1h + h^2}{8}.$$

Then, as P_2 approaches P_1 , h and k approach zero and the

$$\text{limit of } \frac{k}{h} = \text{limit of } \frac{3x_1^2 + 3x_1h + h^2}{8} = \frac{3x_1^2}{8}.$$

Hence the slope m of the tangent at P_1 is $m = \frac{3x_1^2}{8}$.

C is symmetrical with respect to O , and the tangents at symmetrical points are parallel since only even powers of x_1 and y_1 occur in the value of m . The tangent at the origin is remarkable in that it crosses the curve.

The method employed in this example is general and may be formulated in the following

Rule to determine the slope of the tangent to a curve C at a point P_1 on C .

First step. Let $P_1(x_1, y_1)$ and $P_2(x_1 + h, y_1 + k)$ be two points on C . Substitute their coordinates in the equation of C and subtract.

Second step. Solve the result of the first step for $\frac{k}{h}$,* the slope of the secant through P_1 and P_2 .

Third step. Find the limit of the result of the second step when h and k approach zero. This limit is the required slope.

* The solution will contain h and k separately, so that the equation is not solved in the ordinary sense.

Ex. 2. Find the slope of the tangent to the semicubical parabola $3y^2 = x^3$ at $P_1(x_1, y_1)$.

Solution. First step. Let $P_1(x_1, y_1)$ and $P_2(x_1 + h, y_1 + k)$ be two points on the curve. Then (Corollary, p. 53)

$$(4) \quad 3y_1^2 = x_1^3$$

$$\text{and } 3y_1^2 + 6ky_1 + 3k^2 = x_1^3 + 3x_1^2h + 3x_1h^2 + h^3.$$

Subtracting,

$$6y_1k + 3k^2 = 3x_1^2h + 3x_1h^2 + h^3.$$

Second step. Factoring,

$$k(6y_1 + 3k) = h(3x_1^2 + 3x_1h + h^2).$$

Hence
$$\frac{k}{h} = \frac{3x_1^2 + 3x_1h + h^2}{6y_1 + 3k}.$$

Third step. As h and k approach zero,

$$\begin{aligned} \text{limit of } \frac{k}{h} &= \text{limit of } \frac{3x_1^2 + 3x_1h + h^2}{6y_1 + 3k} \\ &= \frac{3x_1^2}{6y_1} = \frac{x_1^2}{2y_1}. \end{aligned}$$

Hence the slope of the tangent at P_1 is $m = \frac{x_1^2}{2y_1}$.

At the origin $m = \frac{0}{0}$ and is indeterminate. To find the value of m at the origin, we may either apply the rule a second time, setting $x_1 = 0$ and $y_1 = 0$, or eliminate y_1 from the value of m by means of (4), thus obtaining a value which is determinate at the origin.

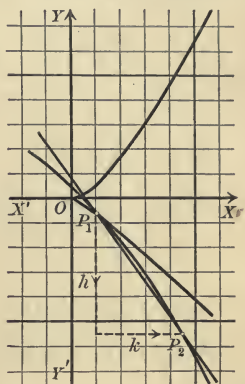

PROBLEMS

1. Find the slopes of the tangents to the following curves at the points indicated.

- | | |
|-----------------------------------------|--------------------------------------------|
| (a) $y^2 = 8x$, $P_1(2, 4)$. | <i>Ans.</i> 1. |
| (b) $x^2 + y^2 = 25$, $P_1(3, -4)$. | <i>Ans.</i> $\frac{3}{4}$. |
| (c) $4x^2 + y^2 = 16$, $P_1(0, 4)$. | <i>Ans.</i> 0. |
| (d) $x^2 - 9y^2 = 81$, $P_1(15, -4)$. | <i>Ans.</i> $-\frac{5}{1^{\frac{1}{2}}}$. |

2. Find the slopes of the tangents to the following curves at the point $P_1(x_1, y_1)$.

- | | |
|------------------------|----------------------------------|
| (a) $y^2 = 6x$. | <i>Ans.</i> $\frac{3}{y_1}$. |
| (b) $16y = x^4$. | <i>Ans.</i> $\frac{x_1^3}{4}$. |
| (c) $x^2 + y^2 = 16$. | <i>Ans.</i> $-\frac{x_1}{y_1}$. |

- (d) $x^2 - y^2 = 4$. Ans. $\frac{x_1}{y_1}$.
- (e) $y^2 = x^3 + x^2$. Ans. $\frac{3x_1^2 + 2x_1}{2y_1}$.
- (f) $4x^2 + y^2 - 16x - 2y = 0$. Ans. $\frac{8 - 4x_1}{y_1 - 1}$.
- (g) $xy = a^2$. Ans. $-\frac{y_1}{x_1}$.
- (h) $xy + y^2 = 8$. Ans. $-\frac{y_1}{x_1 + 2y_1}$.
- (i) $x^2 - y^2 - 8x + 4y = 0$. Ans. $\frac{4 - x_1}{2 - y_1}$.
- (j) $x^2 + y^2 + 6x - 8y = 0$. Ans. $\frac{x_1 + 3}{4 - y_1}$.

84. Equations of tangent and normal. We have at once the **Rule to find the equation of the tangent to a curve C at a point $P_1(x_1, y_1)$ on C .**

First step. Find the slope m of the tangent to C at P_1 (Rule, p. 208).

Second step. Substitute x_1, y_1 , and m in the point-slope form of the equation of a straight line [(V), p. 95].

Third step. Simplify that equation by means of the condition that P_1 lies on C (Corollary, p. 53).

Ex. 1. Find the equation of the tangent to $C: 8y = x^3$ at $P_1(x_1, y_1)$.

Solution. First step. From Ex. 1, p. 208, the slope is $m = \frac{3x_1^2}{8}$.
Second step. Hence the equation of the tangent is

$$y - y_1 = \frac{3x_1^2}{8}(x - x_1),$$

or

$$(1) \quad 3x_1^2x - 8y - 3x_1^3 + 8y_1 = 0.$$

Third step. Since P_1 lies on C , $8y_1 = x_1^3$.

Substituting in (1), we obtain

$$(2) \quad 3x_1^2x - 8y - 2x_1^3 = 0.$$

The **normal** to a curve C at a point P_1 on C is the line through P_1 perpendicular to the tangent to C at P_1 . Its equation is found from that of the tangent by the Rule on p. 114, using Theorem XII, p. 117.

Ex. 2. Find the equation of the normal at P_1 to the curve in Ex. 1.

Solution. The equation of any line perpendicular to (2) has the form (Theorem XII, p. 117)

$$(3) \quad 8x + 3x_1^2y + k = 0.$$

If P_1 lies on this line, then (Corollary, p. 53)

$$8x_1 + 3x_1^2y_1 + k = 0,$$

whence

$$k = -8x_1 - 3x_1^2y_1.$$

Substituting in (3), the equation of the normal is

$$8x + 3x_1^2y - 8x_1 - 3x_1^2y_1 = 0.$$

PROBLEMS

1. Find the equations of the tangents and normals at $P_1(x_1, y_1)$ to the curves in (a) to (e), problem 2, p. 209.

Ans. (a) $y_1y = 3(x + x_1)$, $y_1x + 3y = x_1y_1 + 3y_1$.
 (b) $x_1^3x - 4y = 12y_1$, $4x + x_1^3y = 4x_1 + x_1^3y_1$.
 (c) $x_1x + y_1y = 16$, $y_1x - x_1y = 0$.
 (d) $x_1x - y_1y = 4$, $y_1x + x_1y = 2x_1y_1$.
 (e) $(3x_1^2 + 2x_1)x - 2y_1y - x_1^3 = 0$, $2y_1x + (3x_1^2 + 2x_1)y = 3x_1^2y_1 + 4x_1y_1$.

2. Find the coördinates of a point on each of the curves in (f) to (j), problem 2, p. 209, and then find the equations of the tangent and normal at that point.

3. Find the equations of the tangents and normals to the following curves at the points indicated.

(a) $y^2 - 8x + 4y = 0$, $(0, 0)$. *Ans.* $2x - y = 0$, $x + 2y = 0$.
 (b) $xy = 4$, $(2, 2)$. *Ans.* $x + y = 4$, $x - y = 0$.
 (c) $x^2 - 4y^2 = 25$, $P_1(x_1, y_1)$. *Ans.* $x_1x - 4y_1y = 25$, $4y_1x + x_1y = 5x_1y_1$.
 (d) $x^2 + 2xy = 4$, $P_1(x_1, y_1)$.
Ans. $(x_1 + y_1)x + x_1y = 4$, $x_1x - (x_1 + y_1)y = x_1^2 - x_1y_1 - y_1^2$.
 (e) $y^2 = 2px$, $P_1(x_1, y_1)$. *Ans.* $y_1y = p(x + x_1)$, $y_1x + py = x_1y_1 + py_1$.
 (f) $\frac{x^2}{a^2} + \frac{y^2}{b^2} = 1$, $P_1(x_1, y_1)$.
Ans. $\frac{x_1x}{a^2} + \frac{y_1y}{b^2} = 1$, $\frac{y_1x}{b^2} - \frac{x_1y}{a^2} = \frac{a^2 - b^2}{a^2b^2}x_1y_1$.
 (g) $b^2x^2 - a^2y^2 = a^2b^2$, $P_1(x_1, y_1)$.
Ans. $b^2x_1x - a^2y_1y = a^2b^2$, $a^2y_1x + b^2x_1y = (a^2 + b^2)x_1y_1$.
 (h) $x^2 - y^2 + x^3 = 0$, $(0, 0)$. *Ans.* $y = \pm x$, $x = \mp y$.

85. Equations of tangents and normals to the conic sections.

Theorem I. *The equation of the tangent to the circle*

$$C: x^2 + y^2 = r^2$$

at the point $P_1(x_1, y_1)$ on C is

$$(I) \quad x_1x + y_1y = r^2.$$

Proof. Let $P_1(x_1, y_1)$ and $P_2(x_1 + h, y_1 + k)$ be two points on the circle C .

Then (Corollary, p. 53)

$$(1) \quad x_1^2 + y_1^2 = r^2$$

$$\text{and} \quad (x_1 + h)^2 + (y_1 + k)^2 = r^2,$$

or

$$(2) \quad x_1^2 + 2x_1h + h^2 + y_1^2 + 2y_1k + k^2 = r^2.$$

Subtracting (1) from (2), we have

$$2x_1h + h^2 + 2y_1k + k^2 = 0.$$

Transposing and factoring, this becomes

$$k(2y_1 + k) = -h(2x_1 + h),$$

$$\text{whence} \quad \frac{k}{h} = -\frac{2x_1 + h}{2y_1 + k}$$

is the slope of the secant through P_1 and P_2 .

Letting P_2 approach P_1 , h and k approach zero, so that m , the slope of the tangent at P_1 , is

$$m = \text{limit of } -\frac{2x_1 + h}{2y_1 + k} = -\frac{x_1}{y_1}.$$

The equation of the tangent at P_1 is then (Theorem V, p. 95)

$$y - y_1 = -\frac{x_1}{y_1}(x - x_1),$$

or

$$x_1x + y_1y = x_1^2 + y_1^2.$$

But by (1),

$$x_1^2 + y_1^2 = r^2,$$

so that the required equation is

$$x_1x + y_1y = r^2.$$

Q. E. D.

Theorem II. *The equation of the tangent to the locus of*

$$Ax^2 + Bxy + Cy^2 + Dx + Ey + F = 0$$

at the point $P_1(x_1, y_1)$ on the locus is

(II)

$$Ax_1x + B \frac{y_1x + x_1y}{2} + Cy_1y + D \frac{x + x_1}{2} + E \frac{y + y_1}{2} + F = 0.$$

$$Ax^2 + Bxy + Cy^2 + Dx + Ey + F = 0$$

Proof. Let $P_1(x_1, y_1)$ and $P_2(x_1 + h, y_1 + k)$ be two points on the conic. Then (Corollary, p. 53)

$$(3) \quad Ax_1^2 + Bx_1y_1 + Cy_1^2 + Dx_1 + Ey_1 + F = 0 \text{ and} \\ A(x_1 + h)^2 + B(x_1 + h)(y_1 + k) + C(y_1 + k)^2 + D(x_1 + h) + E(y_1 + k) + F = 0.$$

Clearing parentheses, we have

$$(4) \quad Ax_1^2 + 2Ax_1h + Ah^2 + Bx_1y_1 + Bx_1k + By_1h + Bhk \\ + Cy_1^2 + 2Cy_1k + Ck^2 + Dx_1 + Dh + Ey_1 + Ek + F = 0.$$

Subtracting (3) from (4), we obtain

$$(5) \quad 2Ax_1h + Ah^2 + Bx_1k + By_1h + Bhk + 2Cy_1k + Ck^2 + Dh + Ek = 0.$$

Transposing all the terms containing h and factoring, (5) becomes

$$k(Bx_1 + 2Cy_1 + Ck + E) = -h(2Ax_1 + Ah + By_1 + Bk + D),$$

whence
$$\frac{k}{h} = -\frac{2Ax_1 + By_1 + D + Ah + Bk}{Bx_1 + 2Cy_1 + E + Ck}.$$

This is the slope of the secant P_1P_2 [(1), p. 207].

Letting P_2 approach P_1 , h and k will approach zero and the slope of the tangent is

$$m = -\frac{2Ax_1 + By_1 + D}{Bx_1 + 2Cy_1 + E}.$$

The equation of the tangent line is then (Theorem V, p. 95)

$$y - y_1 = -\frac{2Ax_1 + By_1 + D}{Bx_1 + 2Cy_1 + E}(x - x_1).$$

To reduce this equation to the required form we first clear of fractions and transpose. This gives

$$(2Ax_1 + By_1 + D)x + (Bx_1 + 2Cy_1 + E)y \\ - (2Ax_1^2 + 2Bx_1y_1 + 2Cy_1^2 + Dx_1 + Ey_1) = 0.$$

But from (3) the last parenthesis in this equation equals

$$-(Dx_1 + Ey_1 + 2F).$$

Substituting, the equation of the tangent line is

$$(2Ax_1 + By_1 + D)x + (Bx_1 + 2Cy_1 + E)y + (Dx_1 + Ey_1 + 2F) = 0.$$

Removing the parentheses, collecting the coefficients of A, B, C, D, E , and F , and dividing by (2), we obtain (II). Q. E. D.

Theorem II enables us to write down the equation of the tangent to the locus of any equation of the second degree. It is remembered most easily in the form of the following Rule.

Rule to write the equation of the tangent at $P_1(x_1, y_1)$ to the locus of an equation of the second degree.

First step. Substitute x_1x and y_1y for x^2 and y^2 , $\frac{y_1x + x_1y}{2}$ for xy , and $\frac{x + x_1}{2}$ and $\frac{y + y_1}{2}$ for x and y in the given equation.

Second step. Substitute the numerical values of x_1 and y_1 , if given, in the result of the first step. The result is the required equation.

In like manner, or at once from this Rule, we have

Theorem III. The equation of the tangent at $P_1(x_1, y_1)$ to the
ellipse $b^2x^2 + a^2y^2 = a^2b^2$ is $b^2x_1x + a^2y_1y = a^2b^2$;
hyperbola $b^2x^2 - a^2y^2 = a^2b^2$ is $b^2x_1x - a^2y_1y = a^2b^2$;
parabola $y^2 = 2px$ is $y_1y = p(x + x_1)$.

By the method on p. 210, we obtain

Theorem IV. The equation of the normal at $P_1(x_1, y_1)$ to the
ellipse $b^2x^2 + a^2y^2 = a^2b^2$ is $a^2y_1x - b^2x_1y = (a^2 - b^2)x_1y_1$;
hyperbola $b^2x^2 - a^2y^2 = a^2b^2$ is $a^2y_1x + b^2x_1y = (a^2 + b^2)x_1y_1$;
parabola $y^2 = 2px$ is $y_1x + py = x_1y_1 + py_1$.

PROBLEMS

1. Find the equations of the tangents and normals to the following conics at the points indicated.

(a) $3x^2 - 10y^2 = 17$, (3, 1).

(d) $2x^2 - y^2 = 14$, (3, -2).

(b) $y^2 = 4x$, (9, -6).

(e) $x^2 + 5y^2 = 14$, (3, 1).

(c) $x^2 + y^2 = 25$, (-3, -4).

(f) $x^2 = 6y$, (-6, 6).

(g) $x^2 - xy + 2x - 7 = 0$, (3, 2).

(h) $xy - y^2 + 6x + 8y - 6 = 0$, (-1, 4).

The directed lengths on the tangent and normal from the point of contact to the X -axis are called the **length of the tangent** and the **length of the normal** respectively. Their projections on the X -axis are known as the **subtangent** and **subnormal**.

2. Find the subtangents and subnormals in (a), (b), (d), and (e), problem 1.

Ans. (a) $-\frac{10}{9}, \frac{9}{10}$; (b) $-18, 2$; (d) $-\frac{2}{3}, 6$; (e) $\frac{5}{3}, -\frac{2}{3}$.

3. Find the lengths of the tangents and normals in (a), (b), (d), and (e), problem 1.

Ans. (a) $\frac{1}{9}\sqrt{181}, \frac{1}{10}\sqrt{181}$; (b) $6\sqrt{10}, 2\sqrt{10}$;
 (d) $\frac{2}{3}\sqrt{10}, 2\sqrt{10}$; (e) $\frac{1}{3}\sqrt{34}, \frac{1}{3}\sqrt{34}$.

4. Find the subtangents and subnormals of (a) the ellipse, (b) the hyperbola, (c) the parabola.

$$\text{Ans. (a) } \frac{a^2 - x_1^2}{x_1}, -\frac{b^2}{a^2}x_1; \text{ (b) } \frac{a^2 - x_1^2}{x_1}, \frac{b^2}{a^2}x_1; \text{ (c) } -2x_1, p.$$

5. Show how to draw the tangent to a parabola by means of the subnormal or subtangent.

6. Prove that a point P_1 on a parabola and the intersections of the tangent and normal to the parabola at P_1 with the axis are equally distant from the focus.

7. Show how to draw a tangent to a parabola by means of problem 6.

8. The normal to a circle passes through the center.

9. If the normal to an ellipse passes through the center, the ellipse is a circle.

10. The distance from a tangent to a parabola to the focus is half the length of the normal drawn at the point of contact.

11. Find the equation of the tangent at a vertex to (a) the parabola; (b) the ellipse; (c) the hyperbola.

12. Find the subnormal of a point P_1 on an equilateral hyperbola.

$$\text{Ans. } x_1.$$

13. In an equilateral hyperbola the length of the normal at P_1 is equal to the distance from the origin to P_1 .

86. Tangents to a curve from a point not on the curve.

Ex. 1. Find the equations of the tangents to the parabola $y^2 = 4x$ which pass through $P_2(-3, -2)$.

Solution. Let the point of contact of a line drawn through P_2 tangent to the parabola be P_1 . Then by Theorem III the equation of that line is

$$(1) \quad y_1 y = 2x + 2x_1.$$

Since P_2 lies on this line (Corollary, p. 53),

$$(2) \quad -2y_1 = -6 + 2x_1;$$

and since P_1 lies on the parabola,

$$(3) \quad y_1^2 = 4x_1.$$

The coördinates of P_1 , the point of contact, must satisfy (2) and (3). Solving them, we

find that P_1 may be either of the points $(1, 2)$ or $(9, -6)$.

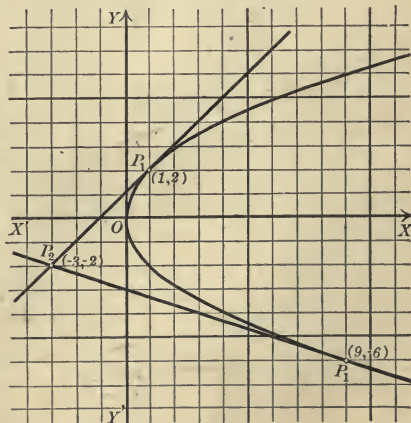

If (1, 2) be the point of contact, the tangent line is, from (1),

$$2y = 2x + 2,$$

or

$$x - y + 1 = 0.$$

If (9, -6) be the point of contact, the tangent line is

$$-6y = 2x + 18,$$

or

$$x - 3y + 9 = 0.$$

The method employed may be stated thus:

Rule to determine the equations of the tangents to a curve C passing through $P_2(x_2, y_2)$ not on C .

First step. Let $P_1(x_1, y_1)$ be the point of tangency of one of the tangents, and find the equation of the tangent to C at P_1 (Rule, p. 210).

Second step. Write the conditions that (x_2, y_2) satisfy the result of the first step and (x_1, y_1) the equation of C , and solve these equations for x_1 and y_1 .

Third step. Substitute each pair of values obtained in the second step in the result of the first step. The resulting equations are the required equations.

PROBLEMS

1. Find the equations of the tangents to the following curves which pass through the point indicated and construct the figure.

(a) $x^2 + y^2 = 25$, (7, -1). *Ans.* $3x - 4y = 25$, $4x + 3y = 25$.

(b) $y^2 = 4x$, (-1, 0). *Ans.* $y = x + 1$, $y + x + 1 = 0$.

(c) $16x^2 + 25y^2 = 400$, (3, -4). *Ans.* $y + 4 = 0$, $3x - 2y = 17$.

(d) $8y = x^3$, (2, 0). *Ans.* $y = 0$, $27x - 8y - 54 = 0$.

(e) $x^2 + 16y^2 - 100 = 0$, (1, 2). *Ans.* None.

(f) $2xy + y^2 = 8$, (-8, 8). *Ans.* $2x + 3y - 8 = 0$, $4x + 3y + 8 = 0$.

(g) $y^2 + 4x - 6y = 0$, $(-\frac{3}{2}, -1)$. *Ans.* $2x - 3y = 0$, $2x - y + 2 = 0$.

(h) $x^2 + 4y = 0$, (0, -6). *Ans.* None.

(i) $x^2 - 3y^2 + 2x + 19 = 0$, (-1, 2).

Ans. $x + 3y - 5 = 0$, $x - 3y + 7 = 0$.

(j) $y^2 = x^3$, $(\frac{4}{3}, 0)$. *Ans.* $y = 0$, $3x - y - 4 = 0$, $3x + y - 4 = 0$.

2. Find the equations of the lines joining the points of contact of the tangents in (a), (b), (c), (f), (g), and (i), problem 1.

Ans. (a) $7x - y = 25$; (b) $x = 1$; (c) $12x - 25y = 100$;

(f) $x = 1$; (g) $x - 2y = 0$; (i) $y = 6$.

87. Properties of tangents and normals to conics.

Theorem V. *If a point moves off to infinity on the parabola $y^2 = 2px$, the tangent at that point approaches parallelism with the X -axis.*

Proof. The equation of the tangent at the point $P_1(x_1, y_1)$ is (Theorem III, p. 214)

$$y_1y = px + px_1.$$

Its slope is (Corollary I, p. 86)

$$m = \frac{p}{y_1}.$$

As P_1 recedes to infinity y_1 becomes infinite, and hence m approaches zero, that is, the tangent approaches parallelism with the X -axis. Q. E. D.

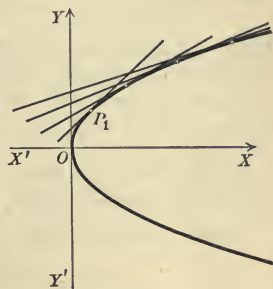

Theorem VI. *If a point moves off to infinity on the hyperbola*

$$b^2x^2 - a^2y^2 = a^2b^2,$$

the tangent at that point approaches coincidence with an asymptote.

Proof. The equation of the tangent at the point $P_1(x_1, y_1)$ is (Theorem III, p. 214)

$$(1) \quad b^2x_1x - a^2y_1y = a^2b^2.$$

Its slope is (Corollary I, p. 86) $m = \frac{b^2x_1}{a^2y_1}.$

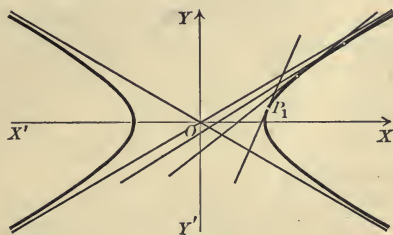

As P_1 recedes to infinity x_1 and y_1 become infinite and m has the indeterminate form $\frac{\infty}{\infty}$.

But since P_1 lies on the hyperbola,

$$b^2x_1^2 - a^2y_1^2 = a^2b^2$$

Dividing by $a^2y_1^2$, transposing, and extracting the square root,

$$\frac{bx_1}{ay_1} = \pm \sqrt{\frac{b^2}{y_1^2} + 1}.$$

Multiplying by $\frac{b}{a}$, $m = \frac{b^2x_1}{a^2y_1} = \pm \frac{b}{a} \sqrt{\frac{b^2}{y_1^2} + 1}.$

From this form of m we see that as y_1 becomes infinite m approaches $\pm \frac{b}{a}$, the slopes of the asymptotes [(5), p. 190], as a limit. The intercepts of (1) are $\frac{a^2}{x_1}$ and $-\frac{b^2}{y_1}$. As their limits are zero the limiting position of the tangent will pass through the origin. Hence the tangent at P_1 approaches coincidence with an asymptote. Q. E. D.

These theorems show an essential distinction between the form of the parabola and that of the right-hand branch of the hyperbola.

Theorem VII. *The tangent and normal to an ellipse bisect respectively the external and internal angles formed by the focal radii of the point of contact.**

Proof. The equation of the lines joining $P_1(x_1, y_1)$ on the ellipse

$$b^2x^2 + a^2y^2 = a^2b^2$$

to the focus $F'(c, 0)$ (Theorem V, p. 185) is (Theorem VII, p. 97)

$$y_1x + (c - x_1)y - cy_1 = 0,$$

and the equation of P_1F is

$$y_1x - (c + x_1)y + cy_1 = 0.$$

The equation of the tangent AB is (Theorem III, p. 214)

$$b^2x_1x + a^2y_1y = a^2b^2.$$

We shall show that the angle θ which AB makes with P_1F' equals the angle ϕ which P_1F makes with AB .

By Theorem X, p. 109,

$$\tan \theta = \frac{a^2y_1^2 - b^2cx_1 + b^2x_1^2}{b^2x_1y_1 + a^2cy_1 - a^2x_1y_1} = \frac{(a^2y_1^2 + b^2x_1^2) - b^2cx_1}{a^2cy_1 - (a^2 - b^2)x_1y_1}.$$

But since P_1 lies on the ellipse,

$$a^2y_1^2 + b^2x_1^2 = a^2b^2,$$

and (Theorem V, p. 185)

$$a^2 - b^2 = c^2.$$

$$\text{Hence } \tan \theta = \frac{a^2b^2 - b^2cx_1}{a^2cy_1 - c^2x_1y_1} = \frac{b^2(a^2 - cx_1)}{cy_1(a^2 - cx_1)} = \frac{b^2}{cy_1}.$$

In like manner

$$\begin{aligned} \tan \phi &= \frac{-b^2cx_1 - b^2x_1^2 - a^2y_1^2}{b^2x_1y_1 - a^2cy_1 - a^2x_1y_1} = \frac{(b^2x_1^2 + a^2y_1^2) + b^2cx_1}{a^2cy_1 + (a^2 - b^2)x_1y_1} \\ &= \frac{a^2b^2 + b^2cx_1}{a^2cy_1 + c^2x_1y_1} = \frac{b^2}{cy_1}. \end{aligned}$$

*This theorem finds application in the so-called whispering galleries.

Hence $\tan \theta = \tan \phi$; and since θ and ϕ are both less than π , $\theta = \phi$. That is, AB bisects the external angle of FP_1 and $F'P_1$, and hence, also, CD bisects the internal angle. Q.E.D.

In like manner we may prove the following theorems.

Theorem VIII. *The tangent and normal to an hyperbola bisect respectively the internal and external angles formed by the focal radii of the point of contact.*

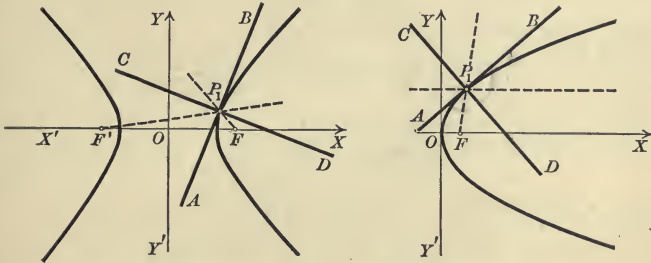

Theorem IX. *The tangent and normal to a parabola bisect respectively the internal and external angles formed by the focal radius of the point of contact and the line through that point parallel to the axis.**

These theorems give rules for constructing the tangent and normal to a conic by means of ruler and compasses.

Construction. To construct the tangent and normal to an ellipse or hyperbola at any point, join that point to the foci and bisect the angles formed by these lines. To construct the tangent and normal to a parabola at any point, draw lines through it to the focus and parallel to the axis, and bisect the angles formed by these lines.

The angle which one curve makes with a second is the angle which the tangent to the first makes with the tangent to the second if the tangents are drawn at a point of intersection.

Theorem X. *Confocal ellipses and hyperbolas intersect at right angles.*

Proof. Let

$$(2) \quad \frac{x^2}{a^2} + \frac{y^2}{b^2} = 1 \quad \text{and} \quad \frac{x^2}{a'^2} - \frac{y^2}{b'^2} = 1$$

be an ellipse and hyperbola with the same foci. Then

$$(3) \quad a^2 - b^2 = a'^2 + b'^2.$$

For if the foci are $(\pm c, 0)$, then in the ellipse $c^2 = a^2 - b^2$ and in the hyperbola $c^2 = a'^2 + b'^2$ (Theorems V and VI, p. 185).

* This theorem finds application in reflectors for lights.

The equations of the tangents to (2) at a point of intersection $P_1(x_1, y_1)$ are (Rule, p. 214)

$$(4) \quad \frac{x_1x}{a^2} + \frac{y_1y}{b^2} = 1 \quad \text{and} \quad \frac{x_1x}{a'^2} - \frac{y_1y}{b'^2} = 1.$$

It is to be proved that the lines (4) are perpendicular, that is (Corollary III, p. 87), that

$$(5) \quad \frac{x_1^2}{a^2a'^2} - \frac{y_1^2}{b^2b'^2} = 0.$$

Since P_1 lies on both curves (2), we have

$$\frac{x_1^2}{a^2} + \frac{y_1^2}{b^2} = 1 \quad \text{and} \quad \frac{x_1^2}{a'^2} - \frac{y_1^2}{b'^2} = 1.$$

Subtracting these equations, we obtain

$$(6) \quad \frac{(a^2 - a'^2)x_1^2}{a^2a'^2} - \frac{(b^2 + b'^2)y_1^2}{b^2b'^2} = 0.$$

But from (3), $a^2 - a'^2 = b^2 + b'^2,$

and hence (6) reduces to (5) and the lines (4) are perpendicular. Q. E. D.

In like manner we prove

Theorem XI. *Two parabolas with the same focus and axis which are turned in opposite directions intersect at right angles.*

Hence the confocal systems in section 82, p. 200 (Ex. 4 and problem 6), are such that the two curves of the system through any point intersect at right angles.

PROBLEMS

1. Tangents to an ellipse and its auxiliary circle (p. 206) at points with the same abscissa intersect on the X -axis.
2. The point of contact of a tangent to an hyperbola is midway between the points in which the tangent meets the asymptotes.
3. The foot of the perpendicular from the focus of a parabola to a tangent lies on the tangent at the vertex.
4. The foot of the perpendicular from a focus of a central conic to a tangent lies on the auxiliary circle (p. 206).
5. Tangents to a parabola from a point on the directrix are perpendicular to each other.
6. Tangents to a parabola at the extremities of a chord which pass through the focus are perpendicular to each other.
7. The ordinate of the point of intersection of the directrix of a parabola and the line through the focus perpendicular to a tangent is the same as that of the point of contact.

8. How may problem 7 be used to draw a tangent to a parabola ?

9. The line drawn perpendicular to a tangent to a central conic from a focus and the line passing through the center and the point of contact intersect on the corresponding directrix.

10. The angle which one tangent to a parabola makes with a second is half the angle which the focal radius drawn to the point of contact of the first makes with that drawn to the point of contact of the second.

11. The product of the distances from a tangent to a central conic to the foci is constant.

12. Tangents to any conic at the ends of the latus rectum (double chord through the focus perpendicular to the principal axis) pass through the intersection of the directrix and principal axis.

13. Tangents to a parabola at the extremities of the latus rectum are perpendicular.

14. The equation of the parabola referred to the tangents in problem 13 is

$$x^2 - 2xy + y^2 - 2\sqrt{2}p(x+y) + 2p^2 = 0,$$

or (compare p. 17)

$$x^{\frac{1}{2}} + y^{\frac{1}{2}} = \sqrt{p\sqrt{2}}.$$

15. The area of the triangle formed by a tangent to an hyperbola and the asymptotes is constant.

16. The area of the parallelogram formed by the asymptotes of an hyperbola and lines drawn through a point on the hyperbola parallel to the asymptotes is constant.

88. Tangent to a curve at the origin. If a curve passes through the origin, the equation of the tangent at that point is easily found.

Ex. 1. Find the equation of the tangent at the origin to

$$C: x^3 - 4x - 2y = 0.$$

Solution. To find the slope of the tangent at $P_1(0, 0)$, let $P_2(0+h, 0+k)$ be a second point on C . The conditions that P_1 and P_2 lie on C give but one equation,

$$h^3 - 4h - 2k = 0,$$

whence the slope of the secant P_1P_2 is [(1), p. 207]

$$m = \frac{k}{h} = -2 + \frac{1}{2}h^2.$$

Letting P_2 approach P_1 , h and k approach zero, and the slope of the tangent is the limit of m , which is -2 .

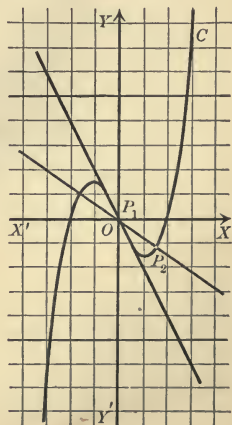

Hence the equation of the tangent is (Theorem I, p. 58)

$$\begin{aligned} & y = -2x, \\ \text{or} \quad & 2x + y = 0. \end{aligned}$$

Notice that this equation may be obtained at once by setting the terms of the first degree in the equation of C equal to zero.

If a curve passes through the origin, the constant term in its equation must be zero (Theorem VI, p. 73), so that its equation must have the form

$$Ax + By + Cx^2 + Dxy + Ey^2 + Fx^3 + \dots = 0,$$

where the dots indicate that there may be other terms whose degree in x and y may be three or greater.

Theorem XII. *The equation of the tangent at the origin to the curve C whose equation arranged according to ascending powers of x and y is*

$$\begin{aligned} & Ax + By + Cx^2 + Dxy + Ey^2 + Fx^3 + \dots = 0, \\ \text{is} \quad & Ax + By = 0. \end{aligned}$$

That is, the equation of the tangent to C at the origin is obtained by setting equal to zero the terms of the first degree in x and y .

Proof. $P_1(0, 0)$ lies on C . Let $P_2(h, k)$ be a second point on C . Then (Corollary, p. 53)

$$Ah + Bk + Ch^2 + Dhk + Ek^2 + Fh^3 + \dots = 0.$$

Transposing all terms containing h , and factoring,

$$k(B + Ek + \dots) = -h(A + Ch + Dk + Fh^2 + \dots).$$

$$\therefore \frac{k}{h} = -\frac{A + Ch + Dk + Fh^2 + \dots}{B + Ek + \dots}.$$

Letting P_2 approach P_1 , the limit of $\frac{k}{h}$, which is the slope of the tangent, is seen to be $-\frac{A}{B}$.

Hence the equation of the tangent is (Theorem V, p. 95)

$$y = -\frac{A}{B}x,$$

or

$$Ax + By = 0.$$

Q.E.D.

If $A = 0$ and $B = 0$, the terms of the lowest degree, if set equal to zero, will be the equation of the two or more lines which will then be tangent to C at the origin. For example, if the equation of C is $x^2 - y^2 + x^3 = 0$, the two lines $x^2 - y^2 = 0$ will be tangent to C at the origin (problem 3, (h), p. 211).

89. Second method of finding the equation of a tangent. The tangent to a curve C at a point P_1 may now be found as follows. Transform C by moving the origin to P_1 (Theorem I, p. 160). The equation of the tangent at P_1 in the *new* coördinates is then found immediately by Theorem XII. Transform it by translating the axes to their first position. The result is the equation of the tangent at P_1 in the given coördinates.

Ex. 1. Find the equation of the tangent to $C: 4x^2 - 2y^2 + x^3 = 0$ at $P_1(-2, 2)$ which lies on C .

Solution. Set (Theorem I, p. 160)

$$x = x' - 2, \quad y = y' + 2.$$

The equation of C becomes

$$4(x' - 2)^2 - 2(y' + 2)^2 + (x' - 2)^3 = 0.$$

Only the terms of the first degree are needed, and *these may be picked out without clearing the parentheses.* The equation of the tangent is therefore

$$4(-4x') - 2 \cdot 4y' + 12x' = 0,$$

or
$$x' + 2y' = 0.$$

To transform to the old axes, set

$$x' = x + 2, \quad y' = y - 2.$$

We thus obtain

$$x + 2y - 2 = 0,$$

which is the equation of the tangent to C at P_1 .

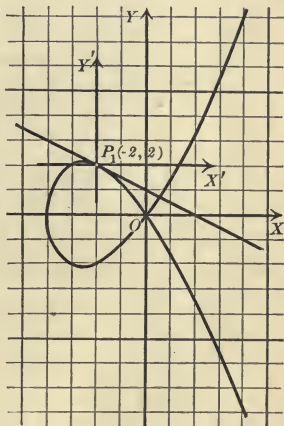

PROBLEMS

1. Find the equations of the tangents at the origin to

(a) $x^2 + 2xy + y^2 - 6x + 8y = 0.$

(d) $y = x^3 - 2x^2 + x.$

(b) $xy - y^2 + x - 3y = 0.$

(e) $x^3 + y^2 + x - y = 0.$

(c) $x^2 + 4xy - 3x + 4y = 0.$

(f) $x^3 + x^2 - 3xy - 4y^2 = 0.$

2. Find the equations of the tangents to the following curves at the points indicated by the method of section 89.

(a) $9x^2 - y^2 + 2x - 4 = 0, (2, 6).$

Ans. $19x - 6y - 2 = 0.$

(b) $x^2 + 4xy + 6y - 7 = 0, (-1, 3).$

Ans. $5x + y + 2 = 0.$

(c) $xy + 6x - 4y - 6 = 0, (2, 3).$

Ans. $9x - 2y - 12 = 0.$

(d) $y^2 + 4x + 2y + 8 = 0, (-4, 2).$

Ans. $2x + 3y + 2 = 0.$

(e) $y^2 = x^3 + 8, (2, 4).$

Ans. $3x - 2y + 2 = 0.$

(f) $y = x^4 - 3x^3 - 5x^2 + 4x + 4, (0, 4).$

Ans. $y = 4x + 4.$

3. Find the angle which the locus of $xy + 4y - 2x = 0$ makes at the origin with that of $x^2 + 4xy + x + 3y = 0$.

$$\text{Ans. } \frac{\pi}{4}.$$

4. Find the angle which the line $2x - 3y - 9 = 0$ makes with the locus of $xy + 6x - 4y - 19 = 0$ at $(3, -1)$.

$$\text{Ans. } \frac{3\pi}{4}.$$

MISCELLANEOUS PROBLEMS

1. Find the equations of the tangents and the normals to the following conics at the points indicated.

(a) $x^2 + 4xy - 4x - 10y + 7 = 0$, $(3, -2)$.

(b) $xy - 4x + 3y - 4 = 0$, $(-1, 4)$.

(c) $xy + y^2 + 2x + 2y = 0$, $(-3, 3)$.

(d) $y^2 + 4x + 6y - 27 = 0$, $(5, -7)$.

(e) $x^2 + 3xy + y^2 - 10y - 1 = 0$, $(2, 3)$.

(f) $x^2 - 8x + 3y - 14 = 0$, $(1, 7)$.

2. Find the equation of one of the tangents to the ellipse $x^2 + 9y^2 - 4x + 9y = 0$ which is parallel to the line $4x - 9y - 36 = 0$.

3. For what point of the parabola $y^2 = 2px$ is the length of the tangent equal to four times the abscissa of the point of contact?

4. What is the length of the tangent to a parabola at an extremity of the latus rectum? Restate the equation of the parabola in problem 14, p. 221, in terms of this length.

5. For what point on the parabola $y^2 = 2px$ is the normal equal to (a) twice the subtangent? (b) the difference between the subtangent and the subnormal?

6. Through a point of the ellipse $b^2x^2 + a^2y^2 = a^2b^2$ and that point of the auxiliary circle with the same abscissa normals are drawn. What is the ratio of the subnormals?

7. For what points of an hyperbola is the subtangent equal to the subnormal?

8. The ordinate of a point on an equilateral hyperbola and the length of the tangent drawn from the foot of that ordinate to the auxiliary circle are equal.

9. A tangent to a parabola meets the directrix and latus rectum produced at points equally distant from the focus.

10. The semi-conjugate axis of a central conic is a mean proportional between the distance from the center to a tangent and the length of the normal drawn at the point of contact.

11. Find the points of the ellipse for which the lengths of the tangent and normal are equal.

12. Any point on an equilateral hyperbola is the middle point of that part of the normal included between the axes of the hyperbola.

13. A circle is drawn through a point on the minor axis of an ellipse and through the foci. Show that the lines drawn through the given point and the points of intersection of the circle and ellipse are normal to the ellipse.

14. How many normals may be drawn through a given point to (a) an ellipse? (b) an hyperbola? (c) a parabola?

CHAPTER X

RELATIONS BETWEEN A LINE AND A CONIC. APPLICATIONS OF THE THEORY OF QUADRATICS

90. Relative positions of a line and conic. If a line and conic are given, it is evident that

- (a) *the line is a secant of the conic,*
- (b) *the line is tangent to the conic, or*
- (c) *the line does not meet the conic.*

The coordinates of the points of intersection of the line and conic are found by solving their equations (Rule, p. 76), which are of the first and second degrees respectively. To solve, we eliminate y^* and arrange the resulting equation in the form

$$(1) \quad Ax^2 + Bx + C = 0.$$

Denote the roots by x_1 and x_2 and the discriminant $B^2 - 4AC$ by Δ . Analytically the three cases above present themselves as follows:

(a) *If Δ is positive, the line is a secant.*

For x_1 and x_2 are real and unequal (Theorem II, p. 3), and hence they are the abscissas of the points of intersection, which must be distinct.

(b) *If Δ is zero, the line is a tangent.*

For in this case $x_1 = x_2$, so that the points of intersection coincide.

(c) *If Δ is negative, the line does not meet the conic.*

For x_1 and x_2 are imaginary, and hence there are no points of intersection (p. 77).

If $A = 0$, one root of (1) is infinite (Theorem IV, p. 15) and one point of intersection is said to be "at infinity."

If $A = 0$ and $B = 0$, then both roots of (1) are infinite and the line is said to be "tangent at infinity."

If $A = 0$, $B = 0$, and $C = 0$, then (1) is satisfied by *all* values of x , and hence has an infinite number of roots. All of the points on the line lie on the conic; that is, the conic is degenerate and consists of straight lines of which the given line is one.

*If one equation does not contain y , then x is found by solving that equation. But for our purposes it is unnecessary to complete the solution.

In solving the equations of the line and conic it might be easier to eliminate x than y . Then (1) would be a quadratic in y , but the result of the discussion would be the same.

If one equation did not contain y , it would be *necessary* for our purposes to eliminate x instead of y , and *vice versa*.

Ex. 1. Determine the relative positions of the line $3x - 2y + 6 = 0$ and the parabola $y^2 + 4x = 0$.

Solution. It is easier to eliminate x than y . Solving the equation of the line for x , we obtain

$$x = \frac{2y - 6}{3}.$$

Substituting in $y^2 + 4x = 0$, we get

$$3y^2 + 8y - 24 = 0.$$

The discriminant of this quadratic is

$$\Delta = 8^2 - 4 \cdot 3 \cdot (-24) = 352.$$

As Δ is positive, the line is a secant.

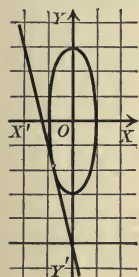
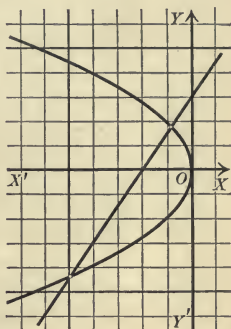

Ex. 2. Determine the relative position of the line $4x + y + 5 = 0$ and the ellipse $9x^2 + y^2 = 9$.

Solution. It is easier to eliminate y than x . From the first equation,

$$y = -(4x + 5).$$

Substituting in the second and arranging, we get

$$25x^2 + 40x + 16 = 0.$$

The discriminant is $\Delta = 40^2 - 4 \cdot 25 \cdot 16 = 0$. Hence the line is a tangent.

Ex. 3. Determine the relative position of the loci of $x^2 - y^2 + 3x - 3y = 0$ and $x - y = 0$.

Solution. Eliminating y , we get

$$x^2 - x^2 + 3x - 3x = 0,$$

or
$$0 \cdot x^2 + 0 \cdot x + 0 = 0.$$

As this equation is true for all values of x , then all of the points on the line lie on the conic. The equation of the conic may evidently be written $(x - y)(x + y + 3) = 0$. The locus of this equation is (Theorem, p. 66) the degenerate conic consisting of the pair of lines

$$x - y = 0, \quad x + y + 3 = 0,$$

of which one is the given line.

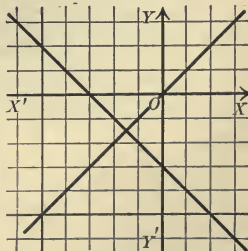

PROBLEMS

1. Determine the relative positions of the loci of the following equations and plot their loci.

- (a) $x + y + 1 = 0, x^2 = 4y$. *Ans.* Tangent.
 (b) $x - 2y + 20 = 0, x^2 + y^2 = 16$. *Ans.* Do not meet.
 (c) $y^2 - 4x = 0, 2x + 3y - 8 = 0$. *Ans.* Secant.
 (d) $x^2 + y^2 - x - 2y = 0, x + 2y = 5$. *Ans.* Tangent.
 (e) $2xy - 3x - y = 0, y + 3x - 6 = 0$. *Ans.* Tangent.
 (f) $x^2 + y^2 - 6x - 8y = 0, x - 2y = 6$. *Ans.* Secant.
 (g) $4x^2 + y^2 - 16x = 0, x + y - 8 = 0$. *Ans.* Do not meet.
 (h) $x^2 + y^2 - 8x - 6 = 0, x + 8 = 0$. *Ans.* Do not meet.
 (i) $8x^2 - 6y^2 + 16x - 32 = 0, 2x - 3y = 0$. *Ans.* Secant.
 (j) $x^2 + xy + 2x + y = 0, 2x + y + 4 = 0$. *Ans.* Tangent.
 (k) $x^2 + 2xy + y^2 + 4x - 4y = 0, x + y = 1$.

Ans. Secant, with one point of intersection at infinity.

- (l) $4x^2 - y^2 + 4x + 1 = 0, 2x - y + 1 = 0$. *Ans.* Line is part of conic.
 (m) $x^2 + 4xy + y^2 + 4x - 6y = 0, 2x - 3y = 0$. *Ans.* Tangent.
 (n) $x^2 - 4y^2 + 8y - 20 = 0, x - 2y + 2 = 0$. *Ans.* Tangent at infinity.
 (o) $x^2 - 6xy + 9y^2 + x - 3y - 2 = 0, x - 3y = 1$.
Ans. Line is part of conic.
 (p) $6x^2 - 5xy - 6y^2 = 18, 2x - 3y = 0$. *Ans.* Tangent at infinity.

2. Find the middle points of the chords of the conics in (c), (f), and (i), problem 1, which are formed by the given line.

Ans. (c) $(\frac{1}{2}, -3)$; (f) $(\frac{2}{5}, -\frac{2}{5})$; (i) $(-\frac{3}{2}, -1)$.

3. Interpret Theorem II, p. 3, geometrically by determining the relative positions of the parabola $y = Ax^2 + Bx + C$ and the line $y = 0$. Construct the figure if

- (a) $A = \frac{1}{4}, B = -1, C = 0$; (b) $A = \frac{1}{4}, B = C = 0$; (c) $A = \frac{1}{4}, B = 1, C = 0$.

91. Relative positions of lines of a system and a conic, and of a line and conics of a system. Given a system of lines (that is, an equation of the first degree containing a parameter k) and a conic, we can determine the values of k for which the lines of the system intersect, are tangent to, or do not meet the conic, as follows.

Eliminate x or y , as may be more convenient, from the equations of the system of lines and the conic, thus obtaining an equation either of the form

$$(1) \quad Ay^2 + By + C = 0 \quad \text{or} \quad Ax^2 + Bx + C = 0.$$

The discriminant Δ will be in general a quadratic in k . Determine the values of k for which Δ is positive, zero, or negative (Theorem III, p. 11) and apply the results of the preceding section.

The same process serves to separate the conics of a system (that is, the loci of an equation of the second degree containing a parameter k) into three classes according as they intersect, are tangent to, or do not meet a given line. Only here the values of k , if any, for which the equation has no locus must be excluded.

Ex. 1. Find the values of k for which the line $y = 2x + k$ intersects, is tangent to, or does not meet the ellipse $x^2 + 4y^2 - 8x + 4y = 0$.

Solution. Eliminating y by substitution in the second equation, we obtain

$$17x^2 + 16kx + 4k^2 + 4k = 0.$$

The discriminant of this quadratic is

$$\Delta = (16k)^2 - 4 \cdot 17(4k^2 + 4k) = -16(k^2 + 17k).$$

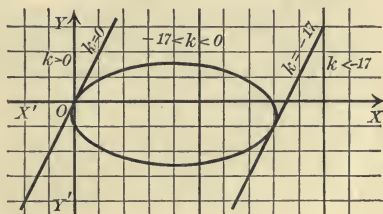

By (a), (b), and (c), p. 226,

- (a) the line is a secant if $-16(k^2 + 17k) > 0$;
- (b) the line is a tangent if $-16(k^2 + 17k) = 0$;
- (c) the line does not meet the ellipse if $-16(k^2 + 17k) < 0$.

Apply Theorem III, p. 11, to the quadratic $-16(k^2 + 17k)$.

Since $\Delta = (-16 \cdot 17)^2$ is positive, $A = -16$, and the roots are 0 and -17 ,

- (a) if $-17 < k < 0$, the quadratic $-16(k^2 + 17k) > 0$;
- (b) if $k = 0$ or -17 , the quadratic $-16(k^2 + 17k) = 0$;
- (c) if $k < -17$ or $k > 0$, the quadratic $-16(k^2 + 17k) < 0$.

Hence

- (a) the line is a secant if $-17 < k < 0$.
- (b) the line is a tangent if $k = 0$ or -17 .
- (c) the line does not meet the ellipse if $k < -17$ or $k > 0$.

The lines of the system are all parallel. The figure shows the two tangent lines and indicates where the lines lie for different values of k .

PROBLEMS

1. Determine the values of k for which the loci of the following equations (a) intersect, (b) are tangent, (c) do not meet. Construct the figure in each case.

(a) $y = kx - 1, x^2 = 4y.$

Ans. (a) $k > 1$ or $k < -1$; (b) $k = \pm 1$; (c) $-1 < k < 1.$

(b) $x + 2y = k, x^2 + y^2 = 5.$

Ans. (a) $-5 < k < 5$; (b) $k = \pm 5$; (c) $k > 5$ or $k < -5.$

(c) $x^2 + y^2 = k, 3x - 4y + 10 = 0.$

Ans. (a) $k > 4$; (b) $k = 4$; (c) $0 \leq k < 4.$

(d) $y = kx + 2, x^2 - 8y = 0.$

Ans. (a) For all values of $k.$

(e) $x^2 + y^2 - 2kx = 0, y = x.$

Ans. (a) For all values except $k = 0$; (b) $k = 0.$

(f) $4x^2 - y^2 = 16, y = kx.$

Ans. (a) $-2 < k < 2$; (b) $k = \pm 2$; (c) $k > 2$ or $k < -2.$

(g) $y^2 = 2kx, x - 2y + 2 = 0.$

Ans. (a) $k > 1$ or $k < 0$; (b) $k = 0$ or 1 ; (c) $0 < k < 1.$

(h) $x^2 + 4y^2 - 8x = 0, y = kx + 2 - 4k.$

Ans. (a) All values except $k = 0$; (b) $k = 0.$

(i) $xy = k, 2x + y + 4 = 0.$

Ans. (a) $k < 2$; (b) $k = 2$; (c) $k > 2.$

(j) $xy + y^2 - 4x + 8y = 0, x - 2y + k = 0.$

Ans. (a) $k > 48$ or $k < 0$; (b) $k = 0$ or 48 ; (c) $48 > k > 0.$

(k) $4x^2 + y^2 - 6x + 6y = 0, y = kx + 1 - k.$

Ans. (a) $k > 1$ or $k < -\frac{1}{11}$; (b) $k = 1$ or $-\frac{1}{11}$; (c) $-\frac{1}{11} < k < 1.$

2. Determine the values of k for which the loci of the following equations are tangent and construct the figure.

(a) $x^2 - 4y + 16 = 0, y = k.$

Ans. $k = 4.$

(b) $9x^2 + 16y^2 = 144, y - x = k.$

Ans. $k = \pm 5.$

(c) $4xy + y^2 + 16 = 0, x = k.$

Ans. $k = \pm 2.$

(d) $x^2 + 4xy + y^2 = k, y = 2x + 1.$

Ans. $k = -\frac{3}{13}.$

(e) $x^2 + 2xy + y^2 + 8x - 6y = 0, 4x - 3y = k.$

Ans. $k = 0.$

(f) $x^2 + 2xy - 4x + 2y = 0, 2x - y + k - 3 = 0.$

Ans. $k = 3$ or $13.$

92. Tangents to a conic. If in the preceding section the value of the discriminant of (1) is zero, then the line and conic are tangent. The equation obtained by setting that discriminant equal to zero is called the **condition for tangency**. Hence the condition for tangency of a line and conic is found by eliminating either x or y from their equations and setting the discriminant of the resulting quadratic equal to zero.

Thus in Ex. 1, p. 229, the condition for tangency is $\Delta = -16(k^2 + 17k) = 0.$

Ex. 1. Find the condition for tangency of the line $\frac{x}{a} + \frac{y}{b} = 1$ and the parabola $y^2 = 2px$.

Solution. Eliminating x by solving the first equation for x and substituting in the second, we get

$$by^2 + 2apy - 2abp = 0.$$

The discriminant of this quadratic is

$$\Delta = (2ap)^2 - 4b(-2abp) = 4ap(ap + 2b^2).$$

Hence the condition for tangency is

$$4ap(ap + 2b^2) = 0 \text{ or } ap(ap + 2b^2) = 0.$$

Rule to find the equation of a line tangent to a given conic and satisfying a second condition.

First step. Write the equation of the system of lines satisfying the second condition.

Second step. Find the condition for tangency of the equation found in the first step and the given conic.

Third step. Solve the equation found in the second step for the value of the parameter of the system of lines and substitute the real values found in the equation of the system. The equations obtained are the required equations.

Ex. 2. Find the equations of the lines with the slope $\frac{1}{2}$ which are tangent to the hyperbola $x^2 - 6y^2 + 12y - 18 = 0$ and find the points of tangency.

Solution. First step. The lines of the system

$$(1) \quad y = \frac{1}{2}x + k$$

have the slope $\frac{1}{2}$ (Theorem I, p. 58).

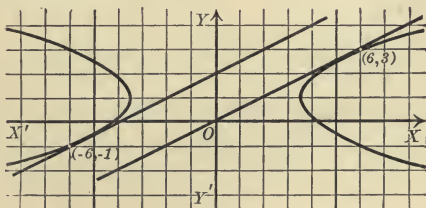

Second step. Solving (1) for x and substituting in the given equation,

$$(2) \quad y^2 + (4k - 6)y + 9 - 2k^2 = 0.$$

Hence the condition for tangency is

$$(4k - 6)^2 - 4(9 - 2k^2) = 0.$$

Third step. Solving this equation, $k = 0$ or 2 .

Substituting in (1), we get the required equations, namely,

$$(3) \quad x - 2y = 0, \quad x - 2y + 4 = 0.$$

To find the points of tangency we substitute each value of k in (2), which then assumes the second form of (7), p. 4, namely,

$$\text{if } k = 0, (2) \text{ becomes } (y - 3)^2 = 0; \therefore y = 3;$$

$$\text{if } k = 2, (2) \text{ becomes } (y + 1)^2 = 0; \therefore y = -1.$$

Hence 3 and -1 are the ordinates of the points of contact. Then, from (1),

$$\text{if } k = 0 \text{ and } y = 3, \text{ we have } x = 6;$$

$$\text{if } k = 2 \text{ and } y = -1, \text{ we have } x = -6.$$

Hence, if $k = 0$, the point of contact is $(6, 3)$;

if $k = 2$, the point of contact is $(-6, -1)$.

The points of contact may also be found by solving each of equations (3) with the given equation.

PROBLEMS

1. Determine the condition for tangency of the loci of the following equations.

- (a) $4x^2 + y^2 - 4x - 8 = 0, y = 2x + k.$ *Ans.* $k^2 + 2k - 17 = 0.$
- (b) $xy + x - 6 = 0, x = ky + 5.$ *Ans.* $k^2 + 14k + 25 = 0.$
- (c) $x^2 - y^2 = a^2, y = kx.$ *Ans.* $k = \pm 1.$
- (d) $x^2 + y^2 = r^2, 4y - 3x = 4k.$ *Ans.* $16k^2 = 25r^2.$
- (e) $x^2 + y^2 = r^2, y = mx + b.$ *Ans.* $(2mb)^2 - 4(1+m^2)(b^2 - r^2) = 0.$
- (f)* $\frac{x^2}{a^2} + \frac{y^2}{b^2} = 1, \frac{x}{\alpha} + \frac{y}{\beta} = 1.$ *Ans.* $\frac{a^2}{\alpha^2} + \frac{b^2}{\beta^2} = 1.$
- (g)* $\frac{x^2}{a^2} - \frac{y^2}{b^2} = 1, \frac{x}{\alpha} + \frac{y}{\beta} = 1.$ *Ans.* $\frac{a^2}{\alpha^2} - \frac{b^2}{\beta^2} = 1.$
- (h)* $\frac{x^2}{a^2} + \frac{y^2}{b^2} = 1, y = mx + \beta.$ *Ans.* $a^2m^2 + b^2 - \beta^2 = 0.$
- (i)* $\frac{x^2}{a^2} - \frac{y^2}{b^2} = 1, y = mx + \beta.$ *Ans.* $a^2m^2 - b^2 - \beta^2 = 0.$
- (j)* $x^2 + y^2 = r^2, x \cos \omega + y \sin \omega - p = 0.$ *Ans.* $p^2 - r^2 = 0.$
- (k)* $2xy = a^2, \frac{x}{\alpha} + \frac{y}{\beta} = 1.$ *Ans.* $\alpha\beta = 2a^2.$
- (l)* $x^2 + y^2 = r^2, Ax + By = 1.$ *Ans.* $A^2r^2 + B^2r^2 = 1.$

* In these problems it is assumed that the constants involved are not zero.

2. Find the equations of the tangents to the following conics which satisfy the condition indicated, and their points of contact. Verify the latter approximately by constructing the figure.

- (a) $y^2 = 4x$, slope = $\frac{1}{2}$. *Ans.* $x - 2y + 4 = 0$.
- (b) $x^2 + y^2 = 16$, slope = $-\frac{3}{4}$. *Ans.* $4x + 3y \pm 20 = 0$.
- (c) $9x^2 + 16y^2 = 144$, slope = $-\frac{1}{4}$. *Ans.* $x + 4y \pm 4\sqrt{10} = 0$.
- (d) $x^2 - 4y^2 = 36$, perpendicular to $6x - 4y + 9 = 0$.
Ans. $2x + 3y \pm 3\sqrt{7} = 0$.
- (e) $x^2 + 2y^2 - x + y = 0$, slope = -1 . *Ans.* $x + y = 1, 2x + 2y + 1 = 0$.
- (f) $x^2 = 4y$, passing through $(0, -1)$. *Ans.* $y = \pm x - 1$.
- (g) $x^2 = 8y$, passing through $(0, 2)$. *Ans.* None.
- (h) $4x^2 - y^2 = 16$, slope = 2 . *Ans.* $y = 2x$.
- (i) $xy + y^2 - 4x + 8y = 0$, parallel to $2x - 4y = 7$.
Ans. $x = 2y, x - 2y + 48 = 0$.
- (j) $4x^2 + y^2 - 6x + 6y = 0$, passing through $(1, 1)$.
Ans. $x - y = 0, 19x + 11y - 30 = 0$.
- (k) $x^2 + 2xy + y^2 + 8x - 6y = 0$, slope = $\frac{3}{4}$.
Ans. $4x - 3y = 0$.
- (l) $x^2 + 2xy - 4x + 2y = 0$, slope = 2 .
Ans. $y = 2x, 2x - y + 10 = 0$.
- (m) $y^2 = 2px$, slope = m . *Ans.* $y = mx + \frac{p}{2m}$.
- (n) $b^2x^2 + a^2y^2 = a^2b^2$, slope = m . *Ans.* $y = mx \pm \sqrt{a^2m^2 + b^2}$.
- (o) $2xy = a^2$, slope = m . *Ans.* $y = mx \pm a\sqrt{-2m}$.

3. Find the highest and lowest points of the conic

- (a) $x^2 + 6xy + 9y^2 - 6x = 0$. *Ans.* Highest $(\frac{2}{3}, \frac{1}{3})$.
- (b) $x^2 - 2xy - 4x - 4y - 8 = 0$. *Ans.* $(0, -2), (-4, -6)$.
- (c) $x^2 - y^2 - 4x + 8y - 16 = 0$. *Ans.* None.

Hint. Find the points of contact of the horizontal tangents.

93. **Tangent in terms of its slope.** The method of the preceding section for finding a tangent with a given slope may be applied to general equations and yield formulas for the equation of a tangent in terms of its slope.

Theorem I. *The equation of a tangent to the parabola $y^2 = 2px$ in terms of its slope m is*

$$(I) \quad y = mx + \frac{p}{2m}.$$

Proof. Eliminating x from $y = mx + k$ and $y^2 = 2px$, we obtain

$$my^2 - 2py + 2pk = 0.$$

Hence the condition for tangency is

$$\Delta = (-2p)^2 - 4m(2pk) = 0,$$

whence

$$k = \frac{p}{2m}.$$

Substituting in $y = mx + k$, we obtain (I).

Q.E.D.

In like manner we prove

Theorem II. *The equation of a tangent in terms of its slope m to the*

circle $x^2 + y^2 = r^2$ is $y = mx \pm r\sqrt{1 + m^2}$;

ellipse $b^2x^2 + a^2y^2 = a^2b^2$ is $y = mx \pm \sqrt{a^2m^2 + b^2}$;

hyperbola $b^2x^2 - a^2y^2 = a^2b^2$ is $y = mx \pm \sqrt{a^2m^2 - b^2}$.

PROBLEMS

1. Find the equations of the common tangents to the following pairs of conics. Construct the figure in each case.

(a) $y^2 = 5x$, $9x^2 + 9y^2 = 16$. *Ans.* $9x \pm 12y + 20 = 0$.

(b) $9x^2 + 16y^2 = 144$, $7x^2 - 32y^2 = 224$. *Ans.* $\pm x - y \pm 5 = 0$.

(c) $x^2 + y^2 = 49$, $x^2 + y^2 - 20y + 99 = 0$.

Ans. $\pm 4x - 3y + 35 = 0$, $\pm 3x - 4y + 35 = 0$.

Hint. Find the equations of a tangent to each conic in terms of its slope and then determine the slope so that the two lines coincide (Theorem III, p. 88).

2. Two tangents, one tangent, or no tangent can be drawn from a point $P_1(x_1, y_1)$ to the locus of

(a) $y^2 = 2px$ according as $y_1^2 - 2px_1$ is positive, zero, or negative.

(b) $b^2x^2 + a^2y^2 = a^2b^2$ according as $b^2x_1^2 + a^2y_1^2 - a^2b^2$ is positive, zero, or negative.

(c) $b^2x^2 - a^2y^2 = a^2b^2$ according as $b^2x_1^2 - a^2y_1^2 - a^2b^2$ is negative, zero, or positive.

3. Two perpendicular tangents to

(a) a parabola intersect on the directrix.

(b) an ellipse intersect on the circle $x^2 + y^2 = a^2 + b^2$.

(c) an hyperbola intersect on the circle $x^2 + y^2 = a^2 - b^2$.

94. The equation in ρ . In the following sections we shall suppose that the line is given in parametric form (Theorem XV, p. 124),

$$(1) \quad \begin{cases} x = x_1 + \rho \cos \alpha, \\ y = y_1 + \rho \cos \beta. \end{cases}$$

The geometric significance of these equations should be constantly borne in mind. A line is given which passes through $P_1(x_1, y_1)$ and whose direction cosines (p. 123) are $\cos \alpha$ and $\cos \beta$ (or whose slope is $m = \frac{\sin \alpha}{\cos \alpha} = \frac{\cos \beta}{\cos \alpha}$, by (I), p. 28). The point (x, y) or $(x_1 + \rho \cos \alpha, y_1 + \rho \cos \beta)$ is that point on the line whose directed distance from P_1 is the variable ρ .

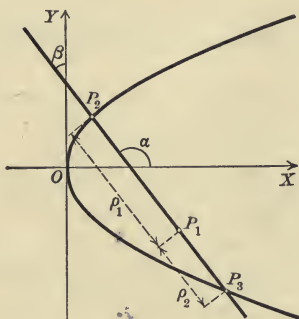

Suppose the conic is the parabola

$$(2) \quad y^2 - 2px = 0.$$

If the point $(x_1 + \rho \cos \alpha, y_1 + \rho \cos \beta)$ on (1) lies on (2), then (Corollary, p. 53)

$$(y_1 + \rho \cos \beta)^2 - 2p(x_1 + \rho \cos \alpha) = 0,$$

or

$$(3) \quad \cos^2 \beta \cdot \rho^2 + (2y_1 \cos \beta - 2p \cos \alpha) \rho + (y_1^2 - 2px_1) = 0.$$

This equation is called the equation in ρ for the parabola. Its roots, ρ_1 and ρ_2 , are the directed lengths P_1P_2 and P_1P_3 from P_1 to the points of intersection of the line and parabola.

For ρ is the distance from P_1 to the point $(x_1 + \rho \cos \alpha, y_1 + \rho \cos \beta)$; and when ρ satisfies equation (3) the point $(x_1 + \rho \cos \alpha, y_1 + \rho \cos \beta)$ lies on the parabola.

Hence

Theorem III. *The directed distances from $P_1(x_1, y_1)$ to the points of intersection of the line*

$$x = x_1 + \rho \cos \alpha, \quad y = y_1 + \rho \cos \beta$$

and the parabola $y^2 = 2px$ are the roots of the equation in ρ ,

$$(III) \quad \cos^2 \beta \cdot \rho^2 + (2y_1 \cos \beta - 2p \cos \alpha) \rho + (y_1^2 - 2px_1) = 0.$$

The equation in ρ for any conic is the equation whose roots are the distances from a point P_1 to the points of intersection of the conic and the line through P_1 whose direction angles are α and β . The method used in proving Theorem III is general and justifies the

Rule for forming the equation in ρ for any conic.

Substitute $x_1 + \rho \cos \alpha$ for x and $y_1 + \rho \cos \beta$ for y in the equation of the conic and arrange the result according to powers of ρ .

For convenience of reference we state the following theorems which are proved by this Rule.

Theorem IV. *The equation in ρ for the central conic $b^2x^2 \pm a^2y^2 - a^2b^2 = 0$ is*

$$(b^2 \cos^2 \alpha \pm a^2 \cos^2 \beta) \rho^2 + (2b^2x_1 \cos \alpha \pm 2a^2y_1 \cos \beta) \rho + (b^2x_1^2 \pm a^2y_1^2 - a^2b^2) = 0.$$

Theorem V. *The equation in ρ for the locus of*

$$Ax^2 + Bxy + Cy^2 + Dx + Ey + F = 0$$

is

$$(V) \quad (A \cos^2 \alpha + B \cos \alpha \cos \beta + C \cos^2 \beta) \rho^2 \\ + [(2Ax_1 + By_1 + D) \cos \alpha + (Bx_1 + 2Cy_1 + E) \cos \beta] \rho \\ + (Ax_1^2 + Bx_1y_1 + Cy_1^2 + Dx_1 + Ey_1 + F) = 0.*$$

The relative position of the line (1) and a conic depends upon the discriminant of the equation in ρ . For according as the roots of the equation in ρ are real and unequal, real and equal, or imaginary (Theorem II, p. 3), the line and conic will intersect, be tangent, or not meet at all.

PROBLEMS

1. Find the equation in ρ for each of the following conics.

(a) $xy = 8$.

(e) $2x^2 + xy + 8x - 4y = 0$.

(b) $x^2 + y^2 = 9$.

(f) $x^2 + 2xy + y^2 - 4x = 0$.

(c) $8x^2 - y^2 = 16$.

(g) $xy + 4x - 8y - 3 = 0$.

(d) $x^2 - y^2 + 4x - 6y = 0$.

(h) $x^2 + 4xy + y^2 - 3x = 0$.

2. What can be said of the coefficients and roots of the equation in ρ

(a) if $P_1(x_1, y_1)$ lies on the conic?

(b) if the line is tangent to the conic at P_1 ?

(c) if the line meets the conic at infinity?

(d) if P_1 is the middle point of the chord formed by the line?

* Notice that the coefficient of ρ^2 is found by substituting $\cos \alpha$ for x and $\cos \beta$ for y in the terms of the *second degree* in the given equation. The constant term is found by substituting x_1 for x and y_1 for y throughout the given equation. Compare the coefficients of $\cos \alpha$ and $\cos \beta$ within the brackets with equations (6) and (7), p. 171.

3. Determine the relative position of the following lines and conics and construct the figures.

(a) $y^2 - 4x + 4 = 0$ $\left\{ \begin{array}{l} x = 3 + \frac{3}{5}\rho, \\ y = -2 + \frac{4}{5}\rho. \end{array} \right.$ *Ans.* Secant.

(b) $4xy + 3y^2 - 4x + 4y - 16 = 0$ $\left\{ \begin{array}{l} x = 2 - \frac{3}{\sqrt{10}}\rho, \\ y = 1 + \frac{1}{\sqrt{10}}\rho. \end{array} \right.$ *Ans.* Tangent.

(c) $4x^2 + 9y^2 - 40x - 72y + 100 = 0$ $\left\{ \begin{array}{l} x = -2 - \frac{1}{\sqrt{2}}\rho, \\ y = -1 + \frac{1}{\sqrt{2}}\rho. \end{array} \right.$ *Ans.* Do not meet.

(d) $3x^2 + xy - 4y^2 - x + y = 0$ $\left\{ \begin{array}{l} x = 3 - \frac{4}{5}\rho, \\ y = -2 + \frac{3}{5}\rho. \end{array} \right.$ *Ans.* Line is part of conic.

(e) $4x^2 - 9y^2 = 36$ $\left\{ \begin{array}{l} x = 2 - \frac{3}{5}\rho, \\ y = 3 + \frac{4}{5}\rho. \end{array} \right.$ *Ans.*- Secant with one point of intersection at infinity.

95. **Tangents.** We shall show how to find the equation of a tangent to a conic by means of the equation in ρ by considering the tangent to the parabola $y^2 - 2px = 0$ at the point $P_1(x_1, y_1)$. Let

(1) $x = x_1 + \rho \cos \alpha, y = y_1 + \rho \cos \beta$

be any secant through P_1 intersecting the parabola at P_2 . One root of the equation in ρ is $\rho_1 = P_1P_2$ and the other is $\rho_2 = 0$. Hence (III), p. 235, becomes (Case I, p. 4)

$$\cos^2 \beta \cdot \rho^2 + (2y_1 \cos \beta - 2p \cos \alpha) \rho = 0.$$

[Or the constant term is zero by the Corollary, p. 53.]

When P_2 approaches P_1 the line becomes tangent (p. 207), and as ρ_1 becomes zero we must have (Case III, p. 5)

(2) $2y_1 \cos \beta - 2p \cos \alpha = 0.$

This is the condition that (1) is tangent to the parabola. Solving (1) for $\cos \alpha$ and $\cos \beta$ and substituting in (2), we obtain

$$2y_1y - 2px - 2y_1^2 + 2px_1 = 0.$$

But since $y_1^2 = 2px_1$ this reduces to

$$y_1y - p(x + x_1) = 0,$$

which is the form given in Theorem III, p. 214.

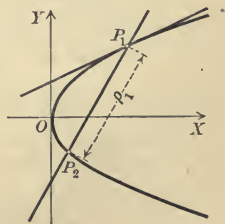

96. Asymptotic directions and asymptotes. If the coefficient of ρ^2 in the equation in ρ is zero, then one root is infinite (Theorem IV, p. 15); and hence the line and conic have one point of intersection at an infinite distance from P_1 . The direction of such a line is called an **asymptotic direction**.

Theorem VI. *The asymptotic directions of the hyperbola are parallel to the asymptotes, of the parabola are parallel to the axis, while the ellipse has no asymptotic directions.*

Proof. Set the coefficient of ρ^2 in the equation in ρ for the hyperbola [(IV), p. 236] equal to zero. This gives

$$b^2 \cos^2 \alpha - a^2 \cos^2 \beta = 0.$$

$$\therefore m = \frac{\cos \beta}{\cos \alpha} = \pm \frac{b}{a}.$$

Therefore the slopes of the asymptotic directions are the same as those of the asymptotes [(5), p. 190].

Similarly for the parabola $m = \frac{\cos \beta}{\cos \alpha} = 0$, so that the asymptotic direction is parallel to the axis.

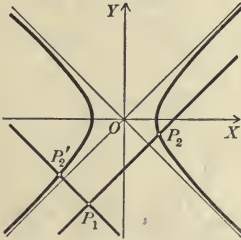

For the ellipse, in like manner, $m = \frac{\cos \beta}{\cos \alpha} = \pm \frac{b}{a} \sqrt{-1}$, so the slopes of

the asymptotic directions are imaginary; that is, there are no asymptotic directions. Q. E. D.

Corollary. *Every line having the asymptotic direction of a conic intersects the conic in but one point in the finite part of the plane.*

If both roots of the equation in ρ become infinite, the line is said to be "tangent to the conic at infinity" and is called an **asymptote**. Using this definition of the asymptotes, we have, in justification of the preliminary definition on p. 189, the following theorem.

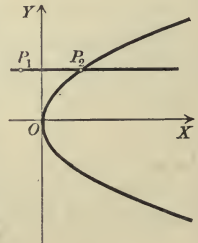

Theorem VII. *The equation of the asymptotes of the hyperbola*

$$b^2x^2 - a^2y^2 = a^2b^2 \text{ is } b^2x^2 - a^2y^2 = 0.$$

Proof. Both roots of the equation in ρ for the hyperbola [(IV), p. 236] will be infinite if (Theorem IV, p. 15)

$$b^2 \cos^2 \alpha - a^2 \cos^2 \beta = 0 \text{ and } 2b^2x_1 \cos \alpha - 2a^2y_1 \cos \beta = 0.$$

From the first equation, $\cos \beta = \pm \frac{b}{a} \cos \alpha$.

Substituting in the second, we get $bx_1 \mp ay_1 = 0$ as the condition that P_1 should lie on an asymptote. But this is the condition that P_1 should lie on one of the lines $bx \mp ay = 0$ or $b^2x^2 - a^2y^2 = 0$. Hence this equation is the equation of the asymptotes. Q. E. D.

The method of the proof justifies the

Rule for finding the equation of the asymptotes of any hyperbola.

First step. Derive the equation in ρ (Rule, p. 236).

Second step. Set the coefficients of ρ^2 and ρ equal to zero.

Third step. Eliminate $\cos \alpha$ and $\cos \beta$ from these equations and drop the subscripts on x_1 and y_1 .

PROBLEMS

1. Find the equations of the tangents to the following conics drawn from the points indicated. (The method of section 95 can be applied whether P_1 lies on the conic or not.)

(a) $xy = 16$, (4, 4). Ans. $x + y = 8$.

(b) $x^2 + 2xy = 4$, (2, 0). Ans. $x + y = 2$.

(c) $x^2 = 4y$, (0, -1). Ans. $x^2 - (y + 1)^2 = 0$, or $x = \pm (y + 1)$.

(d) $x^2 - 3y^2 + 2x + 19 = 0$, (-1, 2). Ans. $(x + 3y - 5)(x - 3y + 7) = 0$.

2. Determine the slopes of the asymptotic directions of the following conics.

(a) $x^2 - xy - 6y^2 - 8x = 0$. Ans. $\frac{1}{3}, -\frac{1}{2}$.

(b) $xy - y^2 + 4x - 6 = 0$. Ans. 0, 1.

(c) $x^2 + 4xy + 4y^2 - 2x = 0$. Ans. $-\frac{1}{2}$.

(d) $4x^2 + xy + y^2 - 3 = 0$. Ans. None.

(e) $9x^2 - 6xy + y^2 - 2y + 5 = 0$. Ans. 3.

(f) $x^2 + 5xy + 4y^2 = 10$. Ans. $-\frac{1}{4}, -1$.

(g) $xy + Dx + Ey + F = 0$. Ans. 0, ∞ .

3. Determine whether the loci of the equations in problem 2 belong to the elliptic, hyperbolic, or parabolic type.

4. Find the equations of the asymptotes of the following hyperbolas.

(a) $xy - y^2 + 2x = 0$. Ans. $y + 2 = 0, x - y + 2 = 0$.

(b) $2x^2 - xy - 4 = 0$. Ans. $x = 0, 2x - y = 0$.

(c) $x^2 - 6xy + 8y^2 = 10$. Ans. $x - 4y = 0, x - 2y = 0$.

(d) $xy - 4x - 3y = 0$. Ans. $x = 3, y = 4$.

(e) $2x^2 - 7xy + 3y^2 = 14$. Ans. $2x - y = 0, x - 3y = 0$.

(f) $x^2 - 4y^2 + 2x + 8y = 0$. Ans. $x - 2y + 3 = 0, x + 2y - 1 = 0$.

5. Find the equations of the asymptotes of the hyperbolas (a), (b), (f), and (g) in problem 2.

Ans. (a) $75x - 25y + 296 = 0, 50x + 25y - 184 = 0$;

(b) $y + 4 = 0, x - y + 4 = 0$;

(f) $x + 4y = 0, x + y = 0$;

(g) $x + E = 0, y + D = 0$.

6. Prove that the parabola has no asymptotes.

7. Show that the asymptotic directions of the locus of $Ax^2 + Bxy + Cy^2 + Dx + Ey + F = 0$ are determined by the locus of $Ax^2 + Bxy + Cy^2 = 0$.

8. By means of problem 7 show that the locus of the general equation of the second degree belongs to the hyperbolic, parabolic, or elliptic type according as $\Delta = B^2 - 4AC$ is positive, zero, or negative.

9. Show how to determine the direction of the axis of any parabola by means of problems 7 and 8.

97. Centers. The problem of this section is to determine the center of symmetry, if there is a center, of the locus of

$$(1) \quad Ax^2 + Bxy + Cy^2 + Dx + Ey + F = 0.$$

That is, we seek a point $P_1(x_1, y_1)$ which is the middle point of every chord of (1) drawn through it.

If P_1 is the middle point of the chord P_2P_3 formed by the line

$$x = x_1 + \rho \cos \alpha, \quad y = y_1 + \rho \cos \beta,$$

then the roots of the equation in ρ must be equal numerically with opposite signs. Hence the coefficient of ρ in (V), p. 236, must be zero (Case II, p. 4).

$$(2) \quad \therefore (2Ax_1 + By_1 + D) \cos \alpha + (Bx_1 + 2Cy_1 + E) \cos \beta = 0.$$

If P_1 is the middle point of every chord passing through it, (2) is satisfied by all values of $\cos \alpha$ and $\cos \beta$. For $\cos \beta = 0$ and $\cos \alpha = 0$ we get

$$(3) \quad 2Ax_1 + By_1 + D = 0, \quad Bx_1 + 2Cy_1 + E = 0,$$

and if equations (3) are satisfied, (2) is always satisfied.

We can solve (3) for a single pair of values of x_1 and y_1 (Theorem IV, p. 90) unless

$$\frac{2A}{B} = \frac{B}{2C}, \text{ or } \Delta = B^2 - 4AC = 0,$$

and the locus of (1) will have a single center. But if $\Delta = 0$ there will be no center unless at the same time $\frac{B}{2C} = \frac{D}{E}$, when every point on the line $2Ax + By + D = 0$ will be a center.

Hence we have

Theorem VIII. *The locus of*

$$Ax^2 + Bxy + Cy^2 + Dx + Ey + F = 0$$

will have a single center of symmetry if $\Delta = B^2 - 4AC$ is not zero. If $\Delta = 0$ there will be no center unless $\frac{B}{2C} = \frac{D}{E}$, when all of the points on a line will be centers.

Corollary. *The center will be the point of intersection of the lines*

$$2Ax + By + D = 0, \quad Bx + 2Cy + E = 0.$$

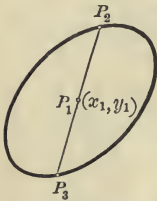

If the locus is of the elliptic or hyperbolic type (p. 195), there will be a single center. But if the locus belongs to the parabolic type, there is no center unless the locus degenerates. If the locus is a pair of parallel lines, then every point on the line midway between them is a center.

To find the center in a numerical example we proceed as in the above proof as far as equations (3) and then solve those equations.

PROBLEMS

1. Find the centers of the following conics.

- (a) $x^2 + xy - 4 = 0$. *Ans.* (0, 0).
- (b) $x^2 - 2xy + y^2 - 4x = 0$. *Ans.* None.
- (c) $xy - 2y^2 + 4x - 4y = 0$. *Ans.* (-12, -4).
- (d) $x^2 - 8xy + 16y^2 + 2x - 8y - 3 = 0$.
Ans. Any point of the line $x - 4y + 1 = 0$.
- (e) $x^2 + 4xy + y^2 - 8x = 0$. *Ans.* $(-\frac{4}{3}, \frac{8}{3})$.
- (f) $4x^2 + 12xy + 9y^2 - 2x + 6 = 0$. *Ans.* None.
- (g) $4x^2 + 12xy + 9y^2 - 4x - 6y - 8 = 0$.

Ans. Any point of the line $2x + 3y - 1 = 0$.

2. If all the coefficients of the general equation of the second degree except B are constant, and if B varies so that $B^2 - 4AC$ approaches zero, how does the center of the locus behave?

98. **Diameters.** The locus of the middle points of a system of parallel chords of a curve is called a **diameter** of the curve.

Consider the ellipse

$$b^2x^2 + a^2y^2 = a^2b^2$$

and the system of parallel lines whose direction angles are α and β . The parametric equations of that line through $P_1(x_1, y_1)$ are (Theorem XV, p. 124)

$$x = x_1 + \rho \cos \alpha, \quad y = y_1 + \rho \cos \beta.$$

If P_1 is the middle point of the chord, then the roots $\rho_1 = P_1P_2$ and $\rho_2 = P_1P_3$ of the equation in ρ [(IV), p. 236] must be equal numerically with opposite signs. Hence (Case II, p. 4)

$$2b^2x_1 \cos \alpha + 2a^2y_1 \cos \beta = 0.$$

Dividing by $2 \cos \alpha$ and setting $m = \frac{\cos \beta}{\cos \alpha}$ (p. 235), we get

$$b^2x_1 + a^2my_1 = 0$$

as the condition that (x_1, y_1) is the middle point of a chord whose slope is m .

This is the condition that P_1 should lie on the line

$$DD' : b^2x + a^2my = 0.$$

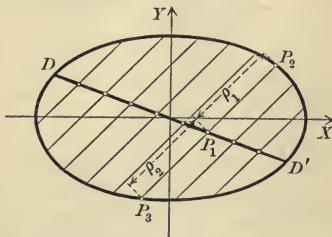

Hence we have

Theorem IX. *The diameter of the ellipse*

$$b^2x^2 + a^2y^2 = a^2b^2$$

bisecting all chords with the slope m is

$$(IX) \quad b^2x + a^2my = 0.$$

This reasoning may be applied to any conic, and justifies the Rule for deriving the equation of a diameter of a conic bisecting all chords with the slope m .

First step. Derive the equation in ρ (Rule, p. 236).

Second step. Set the coefficient of ρ equal to zero.

Third step. Replace x_1 and y_1 by x and y respectively, and $\frac{\cos \beta}{\cos \alpha}$ by m .
The result is the required equation.

By this means we prove

Theorem X. *The diameter bisecting all chords with the slope m of the*
hyperbola $b^2x^2 - a^2y^2 = a^2b^2$ *is* $b^2x - a^2my = 0$;
parabola $y^2 = 2px$ *is* $my = p$.

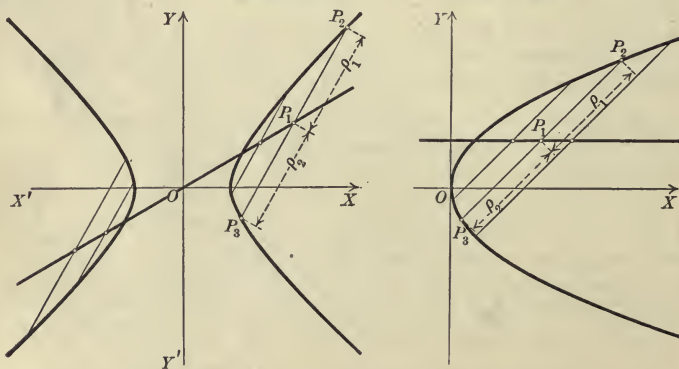

Corollary. *All the diameters of the parabola are parallel to its axis, and every line parallel to the axis is a diameter.*

Theorem XI. *The diameter of the locus of*

$$Ax^2 + Bxy + Cy^2 + Dx + Ey + F = 0$$

bisecting all chords of slope m is

$$(XI) \quad 2Ax + By + D + m(Bx + 2Cy + E) = 0.$$

Corollary. *The diameter passes through the center if the locus has a center, and every line through the center is a diameter.*

Hint. Apply the Corollary, p. 240, and Theorem XIII, p. 119.

PROBLEMS

1. Find the equation of the diameter of each of the following conics which bisects the chords with the given slope m .

- (a) $x^2 - 4y^2 = 16$, $m = 2$. *Ans.* $x - 8y = 0$.
 (b) $y^2 = 4x$, $m = -\frac{1}{2}$. *Ans.* $y + 4 = 0$.
 (c) $xy = 6$, $m = 3$. *Ans.* $y + 3x = 0$.
 (d) $x^2 - xy - 8 = 0$, $m = 1$. *Ans.* $x - y = 0$.
 (e) $x^2 - 4y^2 + 4x - 16 = 0$, $m = -1$. *Ans.* $x + 4y + 2 = 0$.
 (f) $xy + 2y^2 - 4x - 2y + 6 = 0$, $m = \frac{3}{8}$. *Ans.* $2x + 11y - 16 = 0$.

2. Find the equation of that diameter of

- (a) $4x^2 + 9y^2 = 36$ passing through $(3, 2)$. *Ans.* $2x - 3y = 0$.
 (b) $y^2 = 4x$ passing through $(2, 1)$. *Ans.* $y = 1$.
 (c) $xy = 8$ passing through $(-2, 3)$. *Ans.* $3x + 2y = 0$.
 (d) $x^2 - 4y + 6 = 0$ passing through $(3, -4)$. *Ans.* $x = 3$.
 (e) $xy - y^2 + 2x - 4 = 0$ passing through $(5, 2)$. *Ans.* $4x - 9y - 2 = 0$.

3. Find the slope of (XI) if $B^2 - 4AC = 0$. How may the result be interpreted by means of problems 8 and 9, p. 240?

4. What relation exists between m' , the slope of (XI), and m ?

$$\text{Ans. } 2Cmm' + B(m + m') + 2A = 0.$$

5. What does the result of problem 4 become for

- (a) the ellipse $b^2x^2 + a^2y^2 = a^2b^2$? *Ans.* $mm' = -\frac{b^2}{a^2}$.
 (b) the hyperbola $b^2x^2 - a^2y^2 = a^2b^2$? *Ans.* $mm' = \frac{b^2}{a^2}$.
 (c) the parabola $y^2 = 2px$? *Ans.* $m' = 0$.

6. By means of problem 5 discuss the relative directions of a set of parallel chords and the diameter bisecting them.

7. Find the equation of the chord of the locus of

- (a) $x^2 + y^2 = 25$ which is bisected at the point $(2, 1)$.
Ans. $2x + y - 5 = 0$.
 (b) $4x^2 - y^2 = 9$ which is bisected at the point $(4, 2)$.
Ans. $8x - y - 30 = 0$.
 (c) $xy = 4$ which is bisected at the point $(5, 3)$.
Ans. $3x + 5y - 30 = 0$.
 (d) $x^2 - xy - 8 = 0$ which is bisected at the point $(4, 0)$.
Ans. $2x - y - 8 = 0$.

99. Conjugate diameters of central conics. In every system of parallel chords of a central conic there is one which passes through the center and which is therefore a diameter (Corollary to Theorem XI). This diameter and the one bisecting the chords parallel to it are called conjugate diameters.

The ellipse

Let m be the slope of a diameter of the ellipse

$$b^2x^2 + a^2y^2 = a^2b^2.$$

From Theorem IX the slope of the conjugate diameter is (Corollary I, p. 86)

$$m' = -\frac{b^2}{a^2m}.$$

$$\therefore mm' = -\frac{b^2}{a^2}.$$

Hence

Theorem XII. *If m and m' are the slopes of two conjugate diameters of the ellipse $b^2x^2 + a^2y^2 = a^2b^2$, then*

$$(XII) \quad mm' = -\frac{b^2}{a^2}.$$

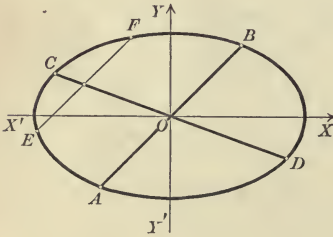

Corollary. *Conjugate diameters of the ellipse lie in different quadrants.*

For m and m' have opposite signs since their product is negative.

The hyperbola

Let m be the slope of a diameter of the hyperbola

$$b^2x^2 - a^2y^2 = a^2b^2.$$

From Theorem X the slope of the conjugate diameter is (Corollary I, p. 86)

$$m' = \frac{b^2}{a^2m}.$$

$$\therefore mm' = \frac{b^2}{a^2}.$$

Hence

Theorem XIII. *If m and m' are the slopes of two conjugate diameters of the hyperbola $b^2x^2 - a^2y^2 = a^2b^2$, then*

$$(XIII) \quad mm' = \frac{b^2}{a^2}.$$

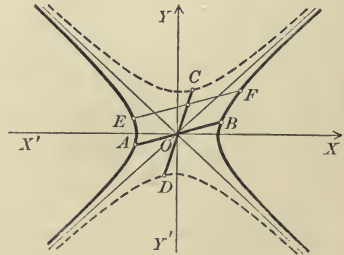

Corollary. *Conjugate diameters of the hyperbola lie in the same quadrant, but on opposite sides of the asymptotes.*

For m and m' have the same sign since their product is positive, and if one is numerically less than $\frac{b}{a}$, the other must be numerically greater than $\frac{b}{a}$ which is the slope of one asymptote [(5), p. 190].

The ellipse

The length of a diameter of the ellipse, or of its conjugate diameter, is that part of the line included between the points of intersection of the line and the ellipse.

Construction. To construct the diameter conjugate to a given diameter AB , draw a chord EF parallel to AB , and then draw the diameter CD bisecting EF .

Theorem XIV. *Given a point $P_1(x_1, y_1)$ on the ellipse $b^2x^2 + a^2y^2 = a^2b^2$, the equation of the diameter conjugate to the diameter through P_1 is*

$$(XIV) \quad b^2x_1x + a^2y_1y = 0.$$

Proof. The diameter through P_1 passes through the origin (Corollary, p. 242), and hence its slope is (Theorem V, p. 35) $m = \frac{y_1}{x_1}$. Then, from (XII), the slope of the conjugate diameter is $m' = -\frac{b^2x_1}{a^2y_1}$. The equation of the line through the origin with the slope m' is (Theorem V, p. 95)

$$y = -\frac{b^2x_1}{a^2y_1}x,$$

which may be written in the form (XIV). Q. E. D.

Corollary. *The points of intersection of (XIV) with the ellipse are*

$$\left(-\frac{ay_1}{b}, \frac{bx_1}{a}\right) \text{ and } \left(\frac{ay_1}{b}, -\frac{bx_1}{a}\right).$$

These are found by the Rule, p. 76.

The hyperbola

The length of that one of two conjugate diameters of the hyperbola which does not meet the hyperbola is defined to be that part of the line included between the branches of the conjugate hyperbola (p. 189).

Construction. To construct the diameter conjugate to a given diameter AB , draw a chord EF parallel to AB , and then draw the diameter CD bisecting EF .

Theorem XV. *Given a point $P_1(x_1, y_1)$ on the hyperbola $b^2x^2 - a^2y^2 = a^2b^2$, the equation of the diameter conjugate to the diameter through P_1 is*

$$(XV) \quad b^2x_1x - a^2y_1y = 0.$$

Proof. The diameter through P_1 passes through the origin (Corollary, p. 242), and hence its slope is (Theorem V, p. 35) $m = \frac{y_1}{x_1}$. Then, from (XIII), the slope of the conjugate diameter is $m' = \frac{b^2x_1}{a^2y_1}$. The equation of the line through the origin with the slope m' is (Theorem V, p. 95)

$$y = \frac{b^2x_1}{a^2y_1}x,$$

which may be written in the form (XV). Q. E. D.

Corollary. *The points of intersection of (XV) with the conjugate hyperbola are*

$$\left(\frac{ay_1}{b}, \frac{bx_1}{a}\right) \text{ and } \left(-\frac{ay_1}{b}, -\frac{bx_1}{a}\right).$$

These are found by the Rule, p. 76.

PROBLEMS

1. What is the relation between the slopes of conjugate diameters of the equilateral hyperbola $2xy = a^2$? *Ans.* $m + m' = 0$.

2. The tangents at the ends of a diameter of (a) an ellipse, (b) an hyperbola, are parallel to the conjugate diameter.

3. The tangent at the end of a diameter of a parabola is parallel to the chords which the diameter bisects.

4. The sum of the squares of two conjugate semi-diameters of an ellipse equals $a^2 + b^2$.

Hint. Let $P_1(x_1, y_1)$ be any point on the ellipse. Find the squares of the distances from the center to P_1 and to one of the points in the Corollary to Theorem XIV, add, and apply the Corollary, p. 53.

5. The difference of the squares of two conjugate semi-diameters of an hyperbola equals $a^2 - b^2$.

Hint. See the hint to problem 4.

6. The angle between two conjugate diameters is $\sin^{-1} \frac{ab}{a'b'}$, where a' and b' are the lengths of the conjugate semi-diameters.

7. Conjugate diameters of an equilateral hyperbola are equal in length.

8. Conjugate diameters of an equilateral hyperbola are equally inclined to the asymptotes.

9. The lines joining the ends of conjugate diameters of an hyperbola are parallel to one asymptote and bisected by the other.

10. The product of the focal radii (problems 8 and 9, p. 194) drawn to any point on (a) an ellipse, (b) an hyperbola, equals the square of the semi-diameter conjugate to the diameter drawn through that point.

11. The asymptotes of an hyperbola are conjugate diameters of an ellipse which has the same axes as the hyperbola.

12. Show that the conjugate diameters of the ellipse in problem 11 are equal.

MISCELLANEOUS PROBLEMS

1. Find the condition for tangency of

(a) $y^2 = 2px$ and $Ax + By + C = 0$.

(b) $b^2x^2 + a^2y^2 = a^2b^2$ and $Ax + By + C = 0$.

(c) $b^2x^2 - a^2y^2 = a^2b^2$ and $Ax + By + C = 0$.

2. Find the points on each of the conics where the tangents are equally inclined to the axes. When is the solution impossible?

3. Find the points on the ellipse where the tangents are parallel to the line joining the positive extremities of the axes.

4. The perpendicular from the focus of a parabola to a tangent intersects the diameter drawn through the point of contact on the directrix.

5. The perpendicular from a focus of a central conic to a diameter intersects the conjugate diameter on the directrix.

6. Tangents at the extremities of a chord of a parabola intersect on the diameter bisecting that chord.

7. Find the equation of (a) the ellipse, (b) the hyperbola, referred to conjugate diameters as axes of coördinates. (See problem 10, p. 172.)

8. Given the equation in ρ for an equation of the second degree; what may be said of the relative positions of the line, the conic, and the point P_1

(a) if the constant term is zero?

(b) if the coefficient of ρ is zero?

(c) if the coefficient of ρ^2 is zero?

(d) if the coefficient of ρ and the constant term are zero?

(e) if the coefficients of ρ^2 and ρ are zero?

(f) if the coefficients of ρ^2 and ρ and the constant term are zero?

(g) if the discriminant is positive, negative, or zero?

9. Tangents to an hyperbola at the extremities of conjugate diameters intersect on the asymptotes.

10. The area of the parallelogram formed by tangents at the extremities of conjugate diameters of (a) an ellipse, (b) an hyperbola, is $4ab$, that is, it is equal to the area of the rectangle whose sides equal the axes.

11. The diagonals of the parallelogram circumscribing the ellipse in problem 10 are conjugate diameters.

12. Chords drawn from a point on (a) an ellipse, (b) an hyperbola, to the extremities of a diameter are parallel to a pair of conjugate diameters.

13. The directrix of a parabola is tangent to the circle described on any focal chord as a diameter.

14. The tangent at the vertex of a parabola is tangent to the circle described on any focal radius as a diameter.

CHAPTER XI

LOCI. PARAMETRIC EQUATIONS

100. The first fundamental problem (p. 53) of Analytic Geometry is to find the equation of a given locus. In this chapter we shall first give some additional problems which may be solved by the Rule on p. 53, using either rectangular or polar coördinates as may be more convenient. We shall then consider two classes of loci problems which are not readily solved by that Rule and which include nearly all of the important loci occurring in Elementary Analytic Geometry.

PROBLEMS

It is expected that the locus in each problem will be constructed and discussed after its equation is found.

1. The base of a triangle is fixed in length and position. Find the locus of the opposite vertex if

- | | |
|-----------------------------------------------------------------------------|-------------------------------------------|
| (a) the sum of the other sides is constant. | <i>Ans.</i> An ellipse. |
| (b) the difference of the other sides is constant. | <i>Ans.</i> An hyperbola. |
| (c) one base angle is double the other. | <i>Ans.</i> An hyperbola. |
| (d) the sum of the base angles is constant. | <i>Ans.</i> A circle. |
| (e) the difference of the base angles is constant. | <i>Ans.</i> A conic. |
| (f) the product of the tangents of the base angles is constant. | <i>Ans.</i> A conic. |
| (g) the product of the other sides is equal to the square of half the base. | <i>Ans.</i> A lemniscate (Ex. 2, p. 152). |
| (h) the median to one of the other sides is constant. | <i>Ans.</i> A circle. |

2. Find the locus of a point the sum of the squares of whose distances from (a) the sides of a square, (b) the vertices of a square, is constant.

Ans. A circle in each case.

3. Find the locus of a point such that the ratio of the square of its distance from a fixed point to its distance from a fixed line is constant.

Ans. A circle.

4. Find the locus of a point such that the ratio of its distance from a fixed point $P_1(x_1, y_1)$ to its distance from a given line $Ax + By + C = 0$ is equal to a constant k .

$$\begin{aligned} \text{Ans. } & (A^2 + B^2 - k^2A^2)x^2 - 2k^2ABxy + (A^2 + B^2 - k^2B^2)y^2 \\ & - 2(A^2x_1 + B^2y_1 + k^2AC)x - 2(A^2y_1 + B^2x_1 + k^2BC)y \\ & + (x_1^2 + y_1^2)(A^2 + B^2) - k^2C^2 = 0. \end{aligned}$$

5. Find the locus of a point such that the ratio of the square of its distance from a fixed line to its distance from a fixed point equals a constant k .

Ans. $x^4 - k^2(x - p)^2 - k^2y^2 = 0$ if the Y -axis is the fixed line and the X -axis passes through the fixed point, p being the distance from the line to the point.

6. Find the locus of a point such that

(a) its radius vector is proportional to its vectorial angle.

Ans. The spiral of Archimedes, $\rho = a\theta$.

(b) its radius vector is inversely proportional to its vectorial angle.

Ans. The hyperbolic or reciprocal spiral, $\rho\theta = a$.

(c) the logarithm of its radius vector is proportional to its vectorial angle.

Ans. The logarithmic spiral, $\log \rho = a\theta$.

(d) the square of its radius vector is inversely proportional to its vectorial angle.

Ans. The lituus, $\rho^2\theta = a^2$.

101. Loci defined by a construction and a given curve. Many important loci are defined as the locus of a point obtained by a given construction from a given curve. The method of treatment of such loci is illustrated by

Ex. 1. Find the locus of the middle points of the chords of the circle $x^2 + y^2 = 25$ which pass through $P_2(3, 4)$.

Solution. Let $P_1(x_1, y_1)$ be any point on the circle. Then a point $P(x, y)$ on the locus is obtained by bisecting P_1P_2 . By the Corollary, p. 39,

$$x = \frac{1}{2}(x_1 + 3), \quad y = \frac{1}{2}(y_1 + 4).$$

$$(1) \quad \therefore x_1 = 2x - 3, \quad y_1 = 2y - 4.$$

Since P_1 lies on the circle (Corollary, p. 53),

$$x_1^2 + y_1^2 = 25.$$

Substituting from (1),

$$(2x - 3)^2 + (2y - 4)^2 = 25,$$

or
$$x^2 + y^2 - 3x - 4y = 0.$$

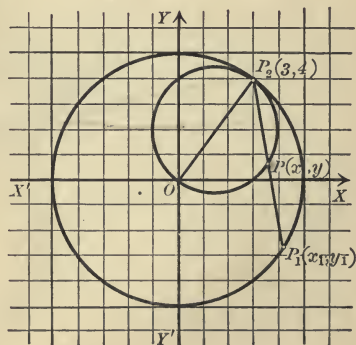

As this equation expresses analytically that $P(x, y)$ satisfies the given condition, it is the equation of the locus.

The locus is easily seen to be a circle described on OP_2 as a diameter, since its center is the point $(\frac{3}{2}, 2)$ and its radius is $\frac{5}{2}$ (Theorem I, p. 131).

The method may evidently be expressed as follows :

Rule for finding the equation of a locus defined by a construction and a given curve.

First step. Find expressions for the coördinates of any point $P_1(x_1, y_1)$ on the given curve in terms of a point $P(x, y)$ on the required curve.

Second step. Substitute the results of the first step for the coördinates in the equation of the given curve and simplify. The result is the required equation.

This Rule may also be applied if polar coördinates are used instead of rectangular coördinates.

Ex. 2. The witch. Find the equation of the locus of a point P constructed as follows: Let OA be a diameter of the circle $x^2 + y^2 - 2ay = 0$ and let any chord OP_1 of the circle meet the tangent at A in a point B . Lines drawn through P_1 and B parallel respectively to OX and OY intersect at a point P on the required locus.

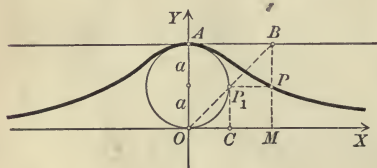

Solution. First step. Let (x, y) be the coördinates of P and (x_1, y_1) of P_1 . Then from the figure

$$(1) \quad y_1 = y.$$

From the similar triangles OCP_1 and P_1PB we have

$$(2) \quad \frac{OC}{P_1P} = \frac{CP_1}{PB}, \text{ or } \frac{x_1}{x - x_1} = \frac{y_1}{2a - y}.$$

For $OC = x_1, P_1P = OM - OC = x - x_1, CP_1 = y_1, PB = MB - MP = 2a - y$.

Solving (1) and (2) for x_1 and y_1 , we obtain

$$(3) \quad x_1 = \frac{xy}{2a}, \quad y_1 = y.$$

Second step. Substituting from (3) in the equation of the given circle $x^2 + y^2 - 2ay = 0$, we get

$$\frac{x^2 y^2}{4a^2} + y^2 - 2ay = 0,$$

or

$$(4) \quad x^2 y = 4a^2(2a - y).$$

The locus of this equation is known as the witch of Agnesi.

Discussion (p. 74). 1. The witch does not pass through the origin (Theorem VI, p. 73).

2. The witch is symmetrical with respect to the Y -axis (Theorem V, p. 73).

3. Its intercept on the Y -axis is $2a$, but the curve does not meet the X -axis (Rule, p. 73).

4. No values of x need be excluded, but all values of y must be excluded except $0 \leq y \leq 2a$.

For, solving (4) for x and y (Rule, p. 73),

$$(5) \quad y = \frac{8a^3}{x^2 + 4a^2}, \quad x = \pm 2a \sqrt{\frac{2a - y}{y}}.$$

Hence y is real for all values of x . But the fraction under the radical is negative if $y > 2a$ or if $y < 0$, and hence these values must be excluded.

5. The witch extends indefinitely to the right and left and approaches nearer and nearer to the X -axis.

For from the first of equations (5), as x increases without limit y decreases and approaches zero.

Ex. 3. The conchoid. Find the locus of a point P constructed as follows: Through a fixed point A on the Y -axis a line is drawn cutting the X -axis at P_1 . On this line a point P is taken so that $P_1P = \pm b$, where b is a constant.

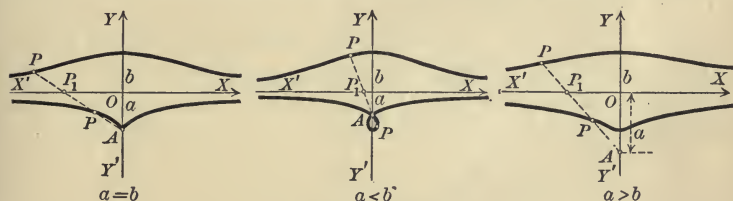

Solution. First step. Use polar coordinates, taking A for the pole and AY for the polar axis. Then if $AO = a$ the equation of XX' is

$$(6) \quad \rho = a \sec \theta.$$

For the equation of a line perpendicular to the polar axis has the form (p. 156) $\rho A \cos \theta + C = 0$, or $\rho = -\frac{C}{A} \sec \theta$, and its intercept on the polar axis is $-\frac{C}{A}$.

If the coordinates of P are (ρ, θ) and of P_1 are (ρ_1, θ_1) , then in any one of the figures we have by definition

$$AP = AP_1 \pm b.$$

$$\therefore \theta_1 = \theta, \rho_1 = \rho \mp b.$$

Second step. Substituting in (6), we obtain

$$(7) \quad \rho = a \sec \theta \pm b.$$

The locus of this equation is called the *conchoid of Nicomedes*. It has three distinct forms according as a is greater, equal to, or less than b .

Discussion (p. 151). 1. The intercepts on the polar axis AY are $a + b$ and $a - b$.

The pole also will lie on the conchoid if $a \sec \theta \pm b = 0$ or $\theta = \sec^{-1} \left(\pm \frac{b}{a} \right)$.

2. The conchoid is symmetrical with respect to the polar axis AY .

For $\sec(-\theta) = \sec \theta$ by 4, p. 19.

3. The conchoid recedes to infinity in the two opposite directions perpendicular to the polar axis AY .

For if $\theta = \frac{\pi}{2}$ or $\frac{3\pi}{2}$, $\sec \theta = \infty$ and hence $\rho = \infty$.

4. If we transform to rectangular coördinates, using (2), p. 155, we get

$$(x^2 + y^2)(x - a)^2 = b^2x^2.$$

A is now the origin and AY the positive axis of X . To translate the axes to O and rotate them through $-\frac{\pi}{2}$ we set (Theorem III, p. 164) $x = y' + a$, $y = -x'$. We thus obtain

$$(8) \quad x^2y^2 = (y + a)^2(b^2 - y^2),$$

which is the equation of the conchoid referred to OX and OY .

From (8) it is easily seen that the conchoid approaches nearer and nearer to the X -axis as it recedes from the origin.

PROBLEMS

1. Find the locus of a point whose ordinate is half the ordinate of a point on the circle $x^2 + y^2 = 64$. *Ans.* The ellipse $x^2 + 4y^2 = 64$.

2. Find the locus of a point which cuts off a part of an ordinate of the circle $x^2 + y^2 = a^2$ whose ratio to the whole ordinate is $b : a$.

Ans. The ellipse $b^2x^2 + a^2y^2 = a^2b^2$.

3. Find the locus of a point which divides an ordinate of (a) $x^2 + y^2 = r^2$, (b) $y^2 = 2px$, (c) $2xy = a^2$ into segments whose ratio is λ .

Ans. (a) $\lambda^2x^2 + (1 + \lambda)^2y^2 = \lambda^2r^2$; (b) $(1 + \lambda)^2y^2 = 2\lambda^2px$;

(c) $2(1 + \lambda)xy = \lambda a^2$.

4. Find the locus of the middle points of the chords of (a) an ellipse, (b) a parabola, (c) an hyperbola which pass through a fixed point $P_2(x_2, y_2)$ on the curve.

Ans. A conic of the same type for which the values of a and b or of p are half the values of those constants for the given conic.

5. Lines are drawn from the point $(0, 4)$ to the hyperbola $x^2 - 4y^2 = 16$. Find the locus of the points which divide these lines in the ratio 1 : 2.

$$\text{Ans. } 9x^2 - 36y^2 + 192y - 272 = 0.$$

6. Lines drawn from the focus of the conic (II), p. 178, are extended their own lengths. Find the locus of their extremities.

Ans. A conic with the same focus and eccentricity whose directrix is $x = -2p$.

7. Lines are drawn from a fixed point $P_2(x_2, y_2)$ to (a) the line $Ax + By + C = 0$, (b) the parabola $y^2 = 2px$, (c) the central conic $Ax^2 + By^2 + F = 0$. Find the locus of the points dividing these lines in the ratio λ .

- Ans.* (a) a straight line parallel to the given line ;
 (b) a parabola whose axis is parallel to that of the given parabola ;
 (c) a central conic whose axes are parallel to those of the given conic.

8. Find the locus of the middle points of chords of an ellipse which join the extremities of a pair of conjugate diameters.

$$\text{Ans. } 2b^2x^2 + 2a^2y^2 = a^2b^2.$$

9. A chord OP_1 of the circle $x^2 + y^2 + ax = 0$ which passes through the origin is extended a distance $P_1P = a$. Find the locus of P .

$$\text{Ans. The cardioid } \begin{cases} (x^2 + y^2 + ax)^2 = a^2(x^2 + y^2), \\ \text{or} & \rho = a(1 - \cos \theta). \end{cases}$$

10. A chord OP_1 of the circle $x^2 + y^2 - 2ax = 0$ meets the line $x = 2a$ at a point A . Find the locus of a point P on the line OP_1 such that $OP = P_1A$.

$$\text{Ans. The cissoid of Diocles } \begin{cases} y^2(2a - x) = x^3, \\ \text{or} & \rho = 2a \sin \theta \tan \theta. \end{cases}$$

11. Find the locus of the point P in problem 9 if $P_1P = b$.

Ans. The limaçon of Pascal, $\rho = b - a \cos \theta$. The limaçon has three distinct forms according as $b \leq a$.

102. Parametric equations of a curve. Equations (XV), p. 124,

$$x = x_1 + \rho \cos \alpha, \quad y = y_1 + \rho \cos \beta,$$

are called the parametric equations of the straight line because they give the values of the coördinates of any point (x, y) on the line in terms of a single variable parameter ρ . In general, if two

equations give the values of the coördinates of any point (x, y) on a curve in terms of a single variable parameter, those equations are called **parametric equations** of the curve.

Ex. 1. Find parametric equations of the circle whose center is the origin and whose radius is r .

Solution. Let $P(x, y)$ be any point on the circle and denote $\angle XOP$ by θ . Then from the figure

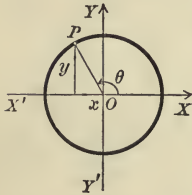

$$(1) \quad x = r \cos \theta, \quad y = r \sin \theta.$$

These are the required equations. They possess two properties analogous to those of the equation of the locus (p. 53).

1. Corresponding to any point P on the locus there is a value of θ such that the values of x and y given by (1) are the coördinates of P .

2. Corresponding to every value of θ for which the values of x and y given by (1) are real numbers there is a point $P(x, y)$ on the locus.

The parameter in the parametric equations of a curve may be chosen in a great many ways, and hence the parametric equations of the same curve will often appear in very different forms.

Thus in Ex. 1, if we had chosen for the parameter half the abscissa of P , denoting it by t , then $t = \frac{x}{2}$, and from the figure $y = \pm \sqrt{r^2 - x^2}$, whence the parametric equation would have been $x = 2t, y = \pm \sqrt{r^2 - 4t^2}$.

Rule to plot a curve whose parametric equations are given.

First step. Assume values of the parameter and compute the corresponding values of x and y from the given equations.

Second step. Plot the points whose coördinates are found in the first step.

Third step. If the points are numerous enough to suggest the general shape of the locus, draw a smooth curve through the points.

Ex. 2. Plot the curve whose parametric equations are

$$(2) \quad x = at^2, \quad y = a^2t^3.$$

Solution. Take $a = \frac{1}{2}$. Then equations (2) become

$$(3) \quad x = \frac{1}{2}t^2, \quad y = \frac{1}{4}t^3.$$

First step. Assume values of t and compute x and y from (3). For example, if $t = 2$, $x = \frac{1}{4}2^2 = 2$, $y = \frac{1}{4}2^3 = 2$. This gives the table :

t	x	y
0	0	0
1	.5	.25
2	2	2
3	4.5	6.75
etc.	etc.	etc.
- 1	.5	- .25
- 2	2	- 2
- 3	4.5	- 6.75
etc.	etc.	etc.

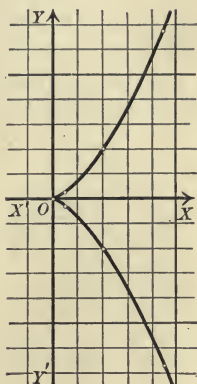

Second step. Plot the points found.

Third step. Draw a smooth curve through these points as in the figure.

Rule to find the equation of a curve in rectangular coördinates whose parametric equations are given.

Eliminate the parameter from the parametric equations.

We shall justify the Rule for the examples in this section.

In Ex. 1, if we square each of the equations (1) and add, we obtain (3, p. 19)

$$x^2 + y^2 = r^2,$$

which is the equation of the given locus (Corollary, p. 58).

In Ex. 2, if we cube the first of equations (2) and square the second, we get

$$x^3 = a^3t^6, \quad y^2 = a^4t^6.$$

$$(4) \quad \therefore y^2 = ax^3.$$

This is the equation of the semicubical parabola (p. 209). To prove that (4) is the equation of the curve obtained in Ex. 2 we must prove two things (p. 53) :

1. *The coördinates of any point $P_1(x_1, y_1)$ on the curve satisfy (4).*

If $P_1(x_1, y_1)$ is on (2), then (1, Ex. 1) there is a value t_1 such that

$$(5) \quad x_1 = at_1^2, \quad y_1 = a^2t_1^3.$$

$$(6) \quad \therefore x_1^3 = a^3t_1^6, \quad y_1^2 = a^4t_1^6.$$

$$(7) \quad \therefore y_1^2 = ax_1^3.$$

Hence x_1 and y_1 satisfy (4).

2. *If x_1 and y_1 satisfy (4), then $P_1(x_1, y_1)$ is on the curve.*

For if (7) is true, then from the first of equations (5) we obtain a value t_1 . Substituting $x_1 = at_1^2$ in (7), we get $y_1 = a^2t_1^3$. Hence x_1 and y_1 are given by (5), and P_1 lies on the curve (2, Ex. 1). This method of proof may be applied in any case.

The parametric equations of a curve are important because it is sometimes easy to express the coördinates of a point on the locus in terms of a parameter when it is otherwise difficult to obtain the equation of the locus.

Ex. 3. The cycloid. Find the parametric equations of the locus of a point P on a circle which rolls along the axis of x .

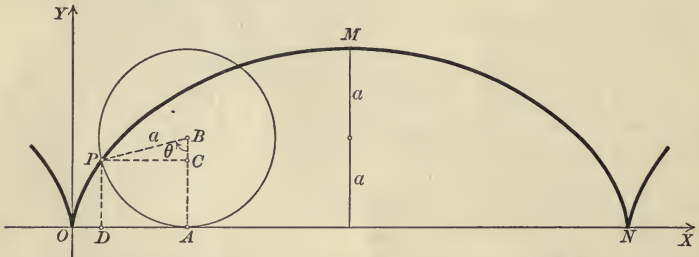

Solution. Take for origin a point O at which the moving point P touched the axis of x . Let a be the radius of the circle and denote the variable angle ABP by θ . Then (p. 18)

$$PC = a \sin \theta, \quad CB = a \cos \theta.$$

$$\text{By definition,} \quad OA = \text{arc } AP = a\theta.$$

For an arc of a circle equals its radius times the subtended angle, from the definition of a radian (p. 19).

Hence from the figure, if (x, y) are the coördinates of P ,

$$x = OD = OA - PC = a\theta - a \sin \theta, \quad y = DP = AB - CB = a - a \cos \theta.$$

$$(8) \quad \therefore \begin{cases} x = a(\theta - \sin \theta), \\ y = a(1 - \cos \theta). \end{cases}$$

These are the parametric equations of the cycloid.

Discussion. 1. The cycloid passes through the origin, for if $\theta = 0$, $x = y = 0$.

2. The cycloid is symmetrical with respect to the Y -axis (Theorem IV, p. 72, and 4, p. 19).

3. Its intercepts on the X -axis are $2n\pi a$, where n is any positive or negative integer, or zero.

For, from the second of equations (8), if $y = 0$, $\cos \theta = 1$. $\therefore \theta = 2n\pi$; and hence from the first of equations (8) $x = a \cdot 2n\pi$.

4. The cycloid lies entirely between the lines $y \geq 0$ and $y = 2a$, for $-1 \leq \cos \theta \leq 1$.

5. The cycloid extends indefinitely to the right and left and consists of parts equal to OMN . For if we replace θ in (8) by $2n\pi + \theta$, y is unchanged while x is increased by $2n\pi a$ (compare Ex. 2, p. 81).

Ex. 4. The hypocycloid of four cusps. Find the parametric equations of the locus of a point P on a circle which rolls on the inside of a circle of four times the radius.

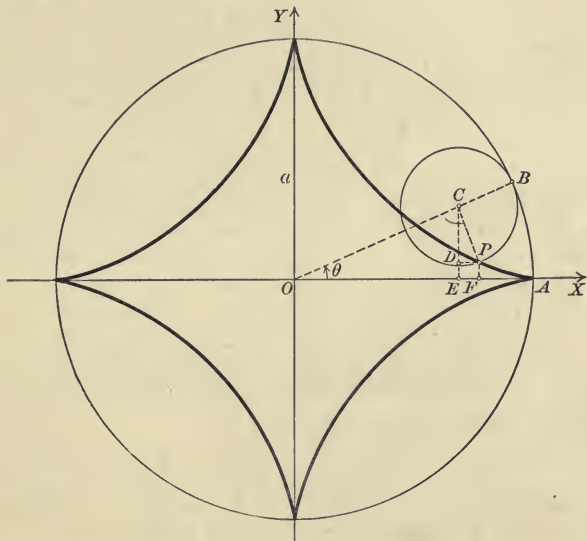

Solution. Take the center of the fixed circle for the origin and let the X -axis pass through a point A where the tracing point P touched the large circle. Denote $\angle AOB$ by θ . Then $\angle BCP = 4\theta$.

For by hypothesis arc $PB = \overset{\circ}{\text{arc}} AB$; and from the definition of a radian (p. 19)

$$\text{arc } PB = \frac{a}{4} \angle BCP, \text{ arc } AB = a\theta. \therefore \frac{a}{4} \angle BCP = a\theta, \text{ or } \angle BCP = 4\theta.$$

But
$$\angle OCE + \angle ECP + \angle PCB = \pi.$$

$$\therefore \frac{\pi}{2} - \theta + \angle ECP + 4\theta = \pi,$$

whence
$$\angle ECP = \frac{\pi}{2} - 3\theta.$$

Then (p. 18)
$$DC = CP \cos\left(\frac{\pi}{2} - 3\theta\right) = \frac{a}{4} \sin 3\theta, \quad (\text{by 6, p. 20})$$

$$DP = CP \sin\left(\frac{\pi}{2} - 3\theta\right) = \frac{a}{4} \cos 3\theta, \quad (\text{by 6, p. 20})$$

$$OE = OC \cos \theta = \frac{3a}{4} \cos \theta,$$

$$EC = OC \sin \theta = \frac{3a}{4} \sin \theta.$$

Hence

$$(9) \quad \begin{cases} x = OE + DP = \frac{3a}{4} \cos \theta + \frac{a}{4} \cos 3\theta, \\ y = EC - DC = \frac{3a}{4} \sin \theta - \frac{a}{4} \sin 3\theta. \end{cases}$$

But from 8, 10, and 14, p. 20, and 3, p. 19,

$$\cos 3\theta = 4 \cos^3 \theta - 3 \cos \theta, \quad \sin 3\theta = 3 \sin \theta - 4 \sin^3 \theta.$$

Substituting in (9), we get

$$(10) \quad x = a \cos^3 \theta, \quad y = a \sin^3 \theta,$$

which are the parametric equations of the hypocycloid of four cusps.

Discussion. 1. The hypocycloid of four cusps does not pass through the origin because there is no value of θ for which $\sin \theta = \cos \theta = 0$.

2. It is symmetrical with respect to both axes and the origin.

For if $\theta = \theta_1$ gives a point (x_1, y_1) on the curve,
 then $\theta = \pi - \theta_1$ gives a point $(-x_1, y_1)$ on the curve,
 $\theta = \pi + \theta_1$ gives a point $(-x_1, -y_1)$ on the curve,
 and $\theta = 2\pi - \theta_1$ gives a point $(x_1, -y_1)$ on the curve.

3. Its intercepts on both axes are $\pm a$.

For if $\theta = 0, \frac{\pi}{2}, \pi, \frac{3\pi}{2}$, then either $x = 0$ and $y = \pm a$, or $y = 0$ and $x = \pm a$.

4. Values of x and y numerically greater than a give no points on the curve since $\sin \theta$ and $\cos \theta$ cannot be numerically greater than 1.

5. The hypocycloid is therefore a closed curve.

PROBLEMS

1. Plot and discuss the following parametric equations. Verify the discussion by finding the equation in rectangular coordinates.

$$(a) \quad x = \frac{2t-1}{t+2}, \quad y = \frac{-t+3}{t+2}.$$

$$(e) \quad x = 4t, \quad y = \frac{2}{t}.$$

$$(b) \quad x = 4 \cos \phi, \quad y = 2 \sin \phi.$$

$$(f) \quad x = 3 + 2 \cos \theta, \quad y = 2 \sin \theta - 1.$$

$$(c) \quad x = 4 \sec \theta, \quad y = 4 \tan \theta.$$

$$(g) \quad x = t + 4, \quad y = \frac{1}{8} t^3.$$

$$(d) \quad x = t - 3, \quad y = \frac{1}{4} t^2.$$

$$(h) \quad x = a \cos^3 \theta, \quad y = b \sin^3 \theta.$$

2. Find the equation in rectangular coordinates of (a) the hypocycloid of four cusps (Ex. 4), (b) the cycloid (Ex. 3).

Ans. (a) $x^{\frac{2}{3}} + y^{\frac{2}{3}} = a^{\frac{2}{3}}$; (b) $x = a \operatorname{vers}^{-1} \frac{y}{a} - \sqrt{2ay - y^2}$, where $\operatorname{vers} \theta = 1 - \cos \theta$, or $\theta = \operatorname{vers}^{-1}(1 - \cos \theta)$.

3. Show that $x = \frac{at+b}{ct+d}, y = \frac{et+f}{ct+d}$, the fractions having the same denominator, are the parametric equations of a straight line. Interpret the meaning of t if (a) $c = d = 1$, (b) $c = 0$.

4. If the denominators of the fractions in problem 3 are different, then the equations given are the parametric equations of an equilateral hyperbola or two perpendicular lines.

5. Find the parametric equations of the ellipse, using as parameter the eccentric angle ϕ , that is, the angle from the major axis to the radius of a point on the auxiliary circle, p. 206, which has the same abscissa as a point on the ellipse. Discuss the equations. *Ans.* $x = a \cos \phi, y = b \sin \phi.$

Hint. Apply problem 10, p. 206.

6. Find the locus of a point Q on the radius BP (Fig., p. 256) if $BQ = b$.

Ans. $\begin{cases} x = a\theta - b \sin \theta, \\ y = a - b \cos \theta. \end{cases}$ The locus is called a prolate or curtate cycloid according as b is greater or less than a .

7. Given a string wrapped around a circle, find the locus of the end of the string as it is unwound.

Hint. Take the center of the circle for origin and let the X -axis pass through the point A on which the end of the string rests. If the string is unwound to a point B , let $\angle AOB = \theta$.

Ans. The involute of a circle $\begin{cases} x = r \cos \theta + r\theta \sin \theta, \\ y = r \sin \theta - r\theta \cos \theta. \end{cases}$

8. A circle of radius r rolls on the inside of a circle whose radius is r' . Find the locus of a point on the moving circle.

Ans. The hypocycloid $\begin{cases} x = (r' - r) \cos \theta + r \cos \frac{r' - r}{r} \theta, \\ y = (r' - r) \sin \theta - r \sin \frac{r' - r}{r} \theta, \end{cases}$
where θ is chosen as in Ex. 4.

9. A circle of radius r rolls on the outside of a circle whose radius is r' . Find the locus of a point on the moving circle.

Ans. The epicycloid $\begin{cases} x = (r' + r) \cos \theta - r \cos \frac{r' + r}{r} \theta, \\ y = (r' + r) \sin \theta - r \sin \frac{r' + r}{r} \theta, \end{cases}$
where θ is chosen as in Ex. 4.

103. Loci defined by the points of intersection of systems of curves. If two systems of curves involve the same parameter, the curves of the systems belonging to the same value of the parameter are called corresponding curves. Many loci are defined, or may be easily regarded, as the locus of the points of intersection of such curves. The method of treatment is illustrated by

Ex. 1. A fixed line AB is drawn parallel to one side of a rectangle, and a variable line CD parallel to the other side. Find the locus of the intersection of AC and BD .

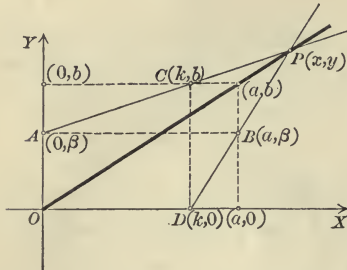

Solution. Let the lengths of the sides be a and b , and take two sides for the axes. Then the vertices are $(0, 0)$, $(a, 0)$, $(0, b)$, and (a, b) .

Let $OA = \beta$ and $OD = k$. Then the coordinates of A , B , C , and D are respectively $(0, \beta)$, (a, β) , (k, b) , and $(k, 0)$. Hence the equations of AC and BD are respectively (Theorem VII, p. 97)

$$(1) \quad (b - \beta)x - ky + \beta k = 0.$$

$$(2) \quad \beta x + (k - a)y - \beta k = 0.$$

These equations represent two systems of lines and involve the same parameter k . To each value of k corresponds a pair of lines intersecting in a point $P(x, y)$ on the locus. Solving (1) and (2), we obtain as the coordinates of P (Rule, p. 76)

$$(3) \quad \begin{cases} x = \frac{a\beta k}{bk + a\beta - ab}, \\ y = \frac{b\beta k}{bk + a\beta - ab}. \end{cases}$$

As these equations express x and y in terms of a parameter k , they are the parametric equations of the locus. The equation of the locus may be obtained by eliminating k (Rule, p. 255). To do this multiply the first of equations (3) by b , the second by a , and subtract. This gives

$$(4) \quad bx - ay = 0.$$

The locus is therefore a diagonal of the rectangle, for this line passes through $(0, 0)$ and (a, b) (Corollary, p. 53).

This equation might also be obtained by adding (1) and (2). But if the elimination were difficult or impossible, we would content ourselves with the parametric equations (3).

The method of solving Ex. 1 may be summed up in the

Rule to find the equation of the locus of the points of intersection of corresponding curves of two systems.

First step. Find the equation of the two* systems of curves defining the locus in terms of the same parameter.

* In some cases the definition involves but one system of curves. In such cases a second system which passes through the points on the locus may frequently be found.

Second step. Solve the equations of the systems for x and y in terms of the parameter. This gives the parametric equations of the locus.

Third step. Find the equation of the locus from the parametric equations (Rule, p. 255).

If only the parametric equations are required, the third step may be omitted.

If only the equation in rectangular coördinates is required, it may be obtained by eliminating the parameter from the equations found in the first step, for the result will be the same as that obtained by eliminating the parameter from the equations found in the second step.

Ex. 2. Find the locus of the points of intersection of two perpendicular tangents to the ellipse $b^2x^2 + a^2y^2 - a^2b^2 = 0$.

Solution. First step. The equation of a tangent in terms of its slope t is (Theorem II, p. 234)

$$(4) \quad y = tx + \sqrt{a^2t^2 + b^2}.$$

The slope of the tangent perpendicular to (4) is (Theorem VI, p. 36) $-\frac{1}{t}$; and hence its equation is (Theorem II, p. 234)

$$(5) \quad y = -\frac{x}{t} + \sqrt{\frac{a^2}{t^2} + b^2}.$$

Second step. As the parametric equations are not required, this step may be omitted.

Third step. To eliminate t from (4) and (5) we write them in the forms

$$\begin{aligned} tx - y &= -\sqrt{a^2t^2 + b^2}, \\ x + ty &= \sqrt{a^2 + b^2t^2}. \end{aligned}$$

Squaring these equations, we obtain

$$\begin{aligned} t^2x^2 - 2txy + y^2 &= a^2t^2 + b^2, \\ x^2 + 2txy + t^2y^2 &= a^2 + b^2t^2. \end{aligned}$$

Adding, $(1 + t^2)x^2 + (1 + t^2)y^2 = (1 + t^2)a^2 + (1 + t^2)b^2$.

Dividing by $1 + t^2$, we get the required equation,

$$x^2 + y^2 = a^2 + b^2.$$

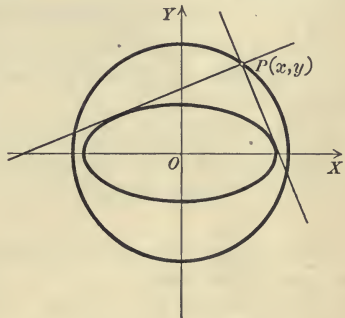

The locus is therefore a circle whose center is the center of the ellipse and whose radius is $\sqrt{a^2 + b^2}$. It is called the director circle.

PROBLEMS

1. Find the locus of the intersections of perpendicular tangents to (a) the parabola, (b) the hyperbola (VI), p. 185.

Ans. (a) The directrix; (b) $x^2 + y^2 = a^2 - b^2$.

2. Find the locus of the point of intersection of a tangent to (a) an ellipse, (b) a parabola, (c) an hyperbola with the line drawn through a focus perpendicular to the tangent.

Ans. (a) $x^2 + y^2 = a^2$; (b) $x = 0$; (c) $x^2 + y^2 = a^2$.

3. Given two fixed points A and B , one on each of the axes, and two variable points A' and B' , one on each axis, such that $OA' + OB' = OA + OB$, find the locus of the intersection of AB' and $A'B$. *Ans.* $x + y = a + b$.

Hint. Let $OA = a$, $OB = b$, and $OA' = a + k$; then $OB' = b - k$.

4. Find the locus of the point of intersection of a tangent to an equilateral hyperbola and the line drawn through the center perpendicular to that tangent.

Ans. The lemniscate (Ex. 2, p. 152) $(x^2 + y^2)^2 = a^2(x^2 - y^2)$.

5. Find the locus of the point of intersection of a tangent to the circle $x^2 + y^2 + 2ax + a^2 - b^2 = 0$ and the line drawn through the origin perpendicular to it.

Ans. The limaçon (problem 11, p. 253) $(x^2 + y^2 + ax)^2 = b^2(x^2 + y^2)$.

6. Find the locus of the point of intersection of the diagonals of a trapezoid formed by drawing a line parallel to one side of a given triangle.

Ans. A median of the triangle.

7. Find the locus of the intersection of the diagonals of a rectangle inscribed in a triangle.

Ans. The line joining the middle points of the base and altitude.

8. Find the locus of the point of intersection of lines drawn through the foci of an ellipse parallel to conjugate diameters. *Ans.* An ellipse.

9. Find the locus of the foot of the perpendicular drawn from the origin to a tangent to the parabola $y^2 + 4ax + 4a^2 = 0$.

Ans. The strophoid $y^2 = x^2 \frac{a+x}{a-x}$.

MISCELLANEOUS PROBLEMS

1. Find the locus of the center of a circle which

(a) has a given radius and passes through a given point.

(b) passes through two given points.

(c) passes through a given point and is tangent to a given line.

(d) is tangent to a given circle and a given straight line.

(e) is tangent to a given circle and passes through a given point.

2. One side of a triangle is fixed and a second side has a constant length. Find the locus of the middle point of the third side.

3. The extremities of a straight line of variable length rest on two perpendicular lines. Find the locus of its middle point if the area of the triangle formed is constant.

4. Find the locus of the middle point of that part of a line through a fixed point $P_1(x_1, y_1)$ which is included between two perpendicular lines.

5. A line of fixed length moves with its extremities on the axes. Show that (a) the locus of any point on the line is an ellipse; (b) the locus of the foot of the perpendicular drawn from the origin to the line is the four-leaved rose $\rho = a \sin 2\theta$.

6. Let the X -axis cut the circle $x^2 + y^2 = a^2$ at A . An arc AB is laid off on the circle equal to the abscissa of a point on the parabola $y^2 = 2px$, and the radius OB is produced a distance BP equal to the ordinate of that point. Show that the locus of P is the parabolic spiral $(\rho - a)^2 = 2a\rho\theta$.

7. The cissoid (problem 10, p. 253) is the locus of the point of intersection of a tangent to the parabola $y^2 + 8ax = 0$ and the perpendicular to it drawn through the origin.

8. Given a fixed point A on the negative part of the X -axis and a line through A meeting the Y -axis at B . On either side of B a length $BP = OB$ is laid off on AB . Show that the locus of P is the strophoid (problem 9, p. 262).

9. One side of a right angle ABC passes through a fixed point D , while a point C on the other side moves along a fixed line EF whose distance from D equals the side BC . Prove that (a) the middle point of BC describes a cissoid (problem 10, p. 253); (b) the vertex B describes a strophoid (problem 9, p. 262).

CHAPTER XII

THE GENERAL EQUATION OF THE SECOND DEGREE

104. If the general equation of the second degree (p. 132)

$$Ax^2 + Bxy + Cy^2 + Dx + Ey + F = 0$$

has a locus, it must be either a conic or a degenerate conic (Theorem XIII, p. 196). The method of determining the exact nature of the locus was to simplify its equation by a transformation of coördinates, a process which is frequently laborious. The principal object of this chapter is to derive rules by which the exact nature of the locus may be easily ascertained. In this connection the expressions

$$\Delta = B^2 - 4AC,$$

$$H = A + C,$$

and

$$\Theta = 4ACF + BDE - AE^2 - CD^2 - FB^2$$

will be of fundamental importance.

105. Condition for a degenerate conic.

Lemma I. *If an equation of the second degree is transformed by a transformation of coördinates, then the left-hand member of the transformed equation can be factored when and only when the left-hand member of the original equation can be factored.**

Proof. For the equations of a transformation of coördinates [(III), p. 164] are of the first degree when solved for either the new or old coördinates, and hence when we substitute in an equation whose left-hand member is factored the result is an equation whose left-hand member is factored. Q. E. D.

Lemma II. *The locus of an equation of the second degree is a degenerate conic when and only when the left-hand member of its equation may be factored.*

Proof. By a transformation of coördinates an equation of the second degree may be reduced to one of the forms

$$(1) \quad Ax^2 + Cy^2 + F = 0, \quad Cy^2 + Dx = 0, \quad Cy^2 + F = 0,$$

where A , C , and D are different from zero (Theorem XIII, p. 196).

* We shall say that the left-hand member of the equation can be *factored* if it can be written as the product of two factors of the *first degree in x and y* (p. 17). Hence

$$x^2 - y^2 = (x + y)(x - y)$$

can be factored, while

$$x^2 - y = (x + \sqrt{y})(x - \sqrt{y})$$

cannot be factored in this sense.

The locus of the first of equations (1) is degenerate when and only when $F=0$, the locus of the second is never degenerate, and the locus of the third is always degenerate.* Hence the locus of an equation of the second degree is degenerate when and only when its equation may be reduced to one of the forms

$$(2) \quad Ax^2 + Cy^2 = 0, \quad Cy^2 + F = 0.$$

These equations may be written in the forms

$$\begin{aligned} (\sqrt{A}x + \sqrt{-C}y)(\sqrt{A}x - \sqrt{-C}y) &= 0, \\ (\sqrt{C}y + \sqrt{-F})(\sqrt{C}y - \sqrt{-F}) &= 0. \end{aligned}$$

Hence equations (2) are forms of equations (1) which can be factored, and they are evidently the only such forms.

Hence the locus of an equation in its simplest form is degenerate when and only when it can be factored, and then by Lemma I the same is true of the locus of any equation of the second degree. Q.E.D.

We now seek the conditions which the coefficients of

$$(3) \quad Ax^2 + Bxy + Cy^2 + Dx + Ey + F = 0$$

must satisfy in order that the left-hand member can be factored.

Arranging (3) according to powers of x , we have

$$(4) \quad Ax^2 + (By + D)x + Cy^2 + Ey + F = 0.$$

Solving for x (which implies that A is not zero), we may write the left-hand member of (4) in the form of (6), p. 3, namely

$$(5) \quad A \left(x - \frac{-(By + D) + \sqrt{(B^2 - 4AC)y^2 + (2BD - 4AE)y + D^2 - 4AF}}{2A} \right) \left(x - \frac{-(By + D) - \sqrt{(B^2 - 4AC)y^2 + (2BD - 4AE)y + D^2 - 4AF}}{2A} \right).$$

These factors will be of the first degree in y as well as x when and only when the quadratic in y under the radical can be written in the second form of (7), p. 4, which can be done when and only when

$$(6) \quad (2BD - 4AE)^2 - 4(B^2 - 4AC)(D^2 - 4AF) = 0.$$

Clearing parentheses and dividing by $-16A$, we obtain

$$(7) \quad 4ACF + BDE - AE^2 - CD^2 - FB^2 = 0.$$

The left-hand member of (7) is called the discriminant of (3) and is denoted by Θ . Hence the left-hand member of (3) can be factored (footnote, p. 264) when and only when its discriminant is zero. Then from Lemma II we have

* The equation $Cy^2 + F = 0$ has no locus if C and F have the same sign (p. 196), but we shall speak of this as a degenerate case to distinguish it from the equation $Ax^2 + Cy^2 + F = 0$, which has no locus if $F \neq 0$, and A , C , and F have the same sign (p. 195), for the former equation has the same form as that of a degenerate parabola (p. 196), while the latter has the same form as that of a central conic.

Theorem I. *The locus of an equation of the second degree*

$$Ax^2 + Bxy + Cy^2 + Dx + Ey + F = 0$$

is degenerate when and only when its discriminant

$$\Theta = 4ACF + BDE - AE^2 - CD^2 - FB^2$$

is zero.

$$\Delta^2 - 4AC = 0$$

PROBLEMS

1. If $A = 0$, then $\Theta = BDE - CD^2 - FB^2$. Show that the locus of

$$Bxy + Cy^2 + Dx + Ey + F = 0$$

will be degenerate when and only when $\Theta = 0$.

Hint. Arrange the given equation according to powers of y .

2. If $A = C = 0$, then $\Theta = DE - FB$, after dividing by B which we suppose is not zero. Show that the locus of

$$Bxy + Dx + Ey + F = 0$$

will be degenerate when and only when $\Theta = 0$.

Hint. If the given equation can be factored, the factors must have the form

$$(A'x + B')(C'y + D') = 0,$$

as otherwise their product would contain x^2 or y^2 .

Multiply these factors, find the conditions that their product should have the same locus as the given equation, and eliminate A' , B' , C' , and D' .

3. Are the loci of the following equations degenerate or non-degenerate?

- | | |
|------------------------------------------|-----------------------------|
| (a) $x^2 - 2xy + y^2 - 2y - 1 = 0$. | <i>Ans.</i> Non-degenerate. |
| (b) $x^2 + 2xy + y^2 + x + y - 2 = 0$. | <i>Ans.</i> Degenerate. |
| (c) $x^2 + y^2 - 4x + 2y + 5 = 0$. | <i>Ans.</i> Degenerate. |
| (d) $x^2 + xy + y^2 + 2x + 3y - 3 = 0$. | <i>Ans.</i> Non-degenerate. |
| (e) $xy + x - y + 7 = 0$. | <i>Ans.</i> Non-degenerate. |
| (f) $x^2 + 2xy - y + 3 = 0$. | <i>Ans.</i> Non-degenerate. |
| (g) $xy + 2x - y - 2 = 0$. | <i>Ans.</i> Degenerate. |

4. Find the real values of k for which the loci of the following equations are degenerate.

- | | |
|-----------------------------------------|-------------------------|
| (a) $kx^2 + (1 - k)y^2 - (2 + k) = 0$. | <i>Ans.</i> 0, 1, -2. |
| (b) $x^2 + (1 + k)y^2 - 4kx - 16 = 0$. | <i>Ans.</i> -1. |
| (c) $xy + k(x^2 - y^2) = 0$. | <i>Ans.</i> All values. |

5. Find all possible cases in which equation (3), p. 265, has no locus.

Hint. Solve for x and apply Theorem III, p. 11, assuming that A is positive and noticing that the discriminant of the quadratic in y under the radical is $-16A\Theta$.

$$\text{Ans. } \Theta > 0, \Delta < 0; \Theta = \Delta = 0, D^2 - 4AF < 0.$$

106. Degenerate conics of a system. Let the equations of two conics, degenerate or non-degenerate, be

$$C_1 : A_1x^2 + B_1xy + C_1y^2 + D_1x + E_1y + F_1 = 0$$

and $C_2 : A_2x^2 + B_2xy + C_2y^2 + D_2x + E_2y + F_2 = 0.$

Then the equation

$$(1) \quad A_1x^2 + B_1xy + C_1y^2 + D_1x + E_1y + F_1 + k(A_2x^2 + B_2xy + C_2y^2 + D_2x + E_2y + F_2) = 0,$$

or

$$(2) \quad (A_1 + kA_2)x^2 + (B_1 + kB_2)xy + (C_1 + kC_2)y^2 + (D_1 + kD_2)x + (E_1 + kE_2)y + (F_1 + kF_2) = 0,$$

where k is an arbitrary constant, will represent a system of conic sections.

If C_1 and C_2 intersect, all the conics of the system will pass through their points of intersection.

This is proved as in the case of straight lines (Theorem XIII, p. 119) and circles (Theorem IV, p. 140).

Ex. 1. Find the values of k for which the conics belonging to the system $x^2 + y^2 - 4 + k(x^2 - y^2 - 1) = 0$ are degenerate.

Solution. The given equation may be written in the form

$$(3) \quad (1 + k)x^2 + (1 - k)y^2 - (4 + k) = 0.$$

Its discriminant is

$$\Theta = -4(1 + k)(1 - k)(4 + k).$$

If the locus of (3) is degenerate, then (Theorem I, p. 266)

$$\Theta = -4(1 + k)(1 - k)(4 + k) = 0.$$

$$\therefore k = -1, 1, \text{ or } -4.$$

If $k = -1$, (3) becomes $2y^2 - 3 = 0$, or $y = \pm \sqrt{\frac{3}{2}}$.

If $k = 1$, (3) becomes $2x^2 - 5 = 0$, or $x = \pm \sqrt{\frac{5}{2}}$.

If $k = -4$, (3) becomes $3x^2 - 5y^2 = 0$, or $y = \pm \sqrt{\frac{3}{5}}x$.

In each case the locus is a pair of lines.

The figure shows the circle $x^2 + y^2 - 4 = 0$, the hyperbola $x^2 - y^2 - 1 = 0$, and the three pairs of lines.

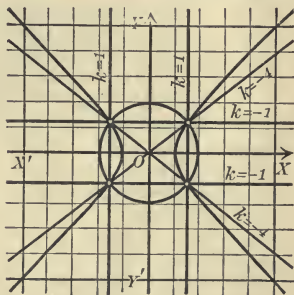

Theorem II. In every system of conics whose equation has the form (1) there is at least one degenerate conic and, in general, there cannot be more than three. These are obtained by substituting for k , in the equation of the system, the roots of its discriminant Θ .

Proof. The discriminant Θ of (1), when set equal to zero, gives an equation of the third degree in k .

For each term in Θ consists of the product of three of the coefficients of (2), and such products will contain the third power of k .

The roots of this cubic equation will be the values of k giving the degenerate conics of the system (Theorem I, p. 266). There are, therefore, not more than three values of k for which the locus is degenerate.

In a special case, however, all of the coefficients in this cubic might be zero, in which case the locus of (2) is degenerate for all values of k (see problem 4, (c), p. 266).

Two or all three of the roots might be equal, and hence there might be but two, or even but one, degenerate conic in the system.

Two of the roots might be imaginary and hence could not be used. But one of them must be real,* and hence there is always at least one real value of k for which the locus of (1) is degenerate. †

Q. E. D.

Systems of conics defined by equations of the form (1) are classified according to the nature of the common solutions of C_1 and C_2 . In Algebra it is shown that two equations of the second degree have, in general, four pairs of common solutions for x and y . Hence five cases arise:

1. Four distinct pairs of solutions.
2. Two pairs are identical and the other two pairs are distinct.
3. Three pairs are identical and the fourth pair is different.
4. Two pairs are identical and the other two pairs are also identical.
5. All four pairs are identical.

If the four pairs of solutions are all real, then these five cases have the following geometrical interpretation.

1. C_1 and C_2 have four distinct points of intersection. All the conics of the system pass through these four points. There are three degenerate conics in the system [Ex. 1 and problem 1, (a)].

2. C_1 and C_2 are tangent at one point and intersect in two other points. All the conics of the system are tangent at the first point and pass through the other two points. There are two degenerate conics in the system [problem 1, (b)].

3. C_1 and C_2 are tangent at one point and intersect in a second point. All the conics of the system are tangent at the first point and pass through the second point. There is but one degenerate conic in the system [problem 1, (c)].

4. C_1 and C_2 are bi-tangent, that is, tangent at two different points. All of the conics of the system are tangent at these two points. There are two degenerate conics in the system [problem 1, (d)].

5. C_1 and C_2 are tangent at one point and do not intersect elsewhere. All of the conics of the system are tangent at this point. There is but one degenerate conic in the system [problem 1, (e)].

* In Algebra it is shown that the imaginary roots of an equation with real coefficients must enter in pairs. Hence if the degree is an *odd* number, one root, at least, must be real.

† It is tacitly assumed, as is true, that not all of the roots of the discriminant, when substituted for k , give equations which have no locus. But this point is not essential for our further reasoning.

PROBLEMS

1. Find the values of k for the degenerate conics of the following systems. Plot C_1 , C_2 , and the degenerate conics.

(a) $x^2 + y^2 - 16 + k(x^2 + 9y^2 - 36) = 0$. *Ans.* $k = -1, -\frac{1}{9}, -\frac{4}{9}$.

(b) $4x^2 + y^2 - 16x + k(x^2 + y^2 - 8x) = 0$. *Ans.* $k = -2, -2, -1$.

(c) $x^2 + 2xy + 2y^2 + 8x + 8y + k(x^2 + 2y^2 + 8y) = 0$.
Ans. $k = -1, -1, -1$.

(d) $x^2 + y^2 - 36 + k(x^2 + 4y^2 - 36) = 0$. *Ans.* $k = -1, -\frac{1}{4}, -1$.

(e) $x^2 + y^2 - 4x + k(4x^2 + y^2 - 4x) = 0$. *Ans.* $k = -1, -1, -1$.

2. Find the points of intersection of C_1 and C_2 in problem 1.

Ans. (a) $(\frac{2}{3}\sqrt{6}, \frac{1}{2}\sqrt{10}), (\frac{2}{3}\sqrt{6}, -\frac{1}{2}\sqrt{10}), (-\frac{2}{3}\sqrt{6}, \frac{1}{2}\sqrt{10}), (-\frac{2}{3}\sqrt{6}, -\frac{1}{2}\sqrt{10})$.

(b) $(0, 0), (0, 0), (\frac{8}{3}, \frac{8}{3}\sqrt{2}), (\frac{8}{3}, -\frac{8}{3}\sqrt{2})$.

(c) $(0, -4), (0, -4), (0, -4), (0, 0)$.

(d) $(6, 0), (6, 0), (-6, 0), (-6, 0)$.

(e) $(0, 0), (0, 0), (0, 0), (0, 0)$.

3. Discuss the following systems of conics.

(a) $x^2 + y^2 - 16 + k(x^2 - 4y^2 + 16) = 0$.

(b) $x^2 - 2y + 4 + k(x^2 + 8y) = 0$.

(c) $xy + 8y + 8 + k(xy + 8) = 0$.

(d) $x^2 + 2y^2 - 8 + k(x^2 + y^2 - 4) = 0$.

(e) $x^2 + 6y + 9 + k(x^2 + 6y) = 0$.

(f) $y^2 - 4x + k(y^2 + 4x) = 0$.

(g) $x^2 - y^2 + 25 + k(x^2 + y^2) = 0$.

(h) $x^2 - y^2 + k(x^2 + y^2) = 0$.

(i) $y^2 - 4x - 16 + k(x^2 - y^2 + 8x + 16) = 0$.

(j) $x^2 - y^2 + k(x^2 - 4y^2 - 3) = 0$.

107. Invariants under a rotation of the axes.

Lemma III. *If the axes are rotated about the origin, then for any point whose old and new coördinates are respectively (x, y) and (x', y') we have*

$$x^2 + y^2 = x'^2 + y'^2.$$

Proof. To rotate the axes through an angle θ we set (Theorem II, p. 162)

$$(1) \quad \begin{cases} x = x' \cos \theta - y' \sin \theta, \\ y = x' \sin \theta + y' \cos \theta. \end{cases}$$

Then
$$\begin{aligned} x^2 + y^2 &= (x' \cos \theta - y' \sin \theta)^2 + (x' \sin \theta + y' \cos \theta)^2 \\ &= x'^2 (\cos^2 \theta + \sin^2 \theta) + y'^2 (\sin^2 \theta + \cos^2 \theta) \\ &= x'^2 + y'^2. \end{aligned} \quad \text{(by 3, p. 19)}$$

Q. E. D.

The lemma is evident geometrically since $x^2 + y^2$ and $x'^2 + y'^2$ are the squares of the distance from the point to the origin [(IV), p. 31] in the new and old coördinates respectively.

We are considering in this chapter the equation

$$(2) \quad Ax^2 + Bxy + Cy^2 + Dx + Ey + F = 0.$$

If we substitute from (1) without simplifying the result, we obtain an equation of the form

$$(3) \quad A'x'^2 + B'x'y' + C'y'^2 + D'x' + E'y' + F = 0,$$

which has the same constant term (Corollary, p. 170).

Consider the system of conics

$$(4) \quad Ax^2 + Bxy + Cy^2 + Dx + Ey + F + k(x^2 + y^2) = 0.$$

If the axes be rotated by substituting from (1), the equation of the system becomes

$$(5) \quad A'x'^2 + B'x'y' + C'y'^2 + D'x' + E'y' + F + k(x'^2 + y'^2) = 0.$$

For the left-hand member of (2) becomes the left-hand member of (3), and $x^2 + y^2$ becomes $x'^2 + y'^2$ by Lemma III.

Denote the discriminants of (2), (3), (4), and (5) by Θ , Θ' , Θ_1 , and Θ_1' respectively. The locus of (4) is degenerate when and only when (Theorem I, p. 266)

$$\Theta_1 = 4(A + k)(C + k)F + BDE - (A + k)E^2 - (C + k)D^2 - FB^2 = 0,$$

or

$$(6) \quad 4Fk^2 + (4AF + 4CF - E^2 - D^2)k + \Theta = 0.*$$

Similarly, the locus of (5) is degenerate when and only when

$$(7) \quad 4Fk^2 + (4A'F + 4C'F - E'^2 - D'^2)k + \Theta' = 0.$$

The roots of (6) and (7) must be the same.

For (4) and (5) are the equations of the same conic referred to different axes. Hence the locus of either equation is degenerate if the locus of the other is degenerate.

Since the coefficients of k^2 in (6) and (7) are equal, the other coefficients must also be equal. Hence

$$(8) \quad \Theta' = \Theta$$

$$\text{and} \quad 4A'F + 4C'F - E'^2 - D'^2 = 4AF + 4CF - E^2 - D^2.$$

An expression involving the coefficients A , B , C , D , E , and F whose value remains unchanged when the axes are changed is called an *invariant* of the general equation of the second degree under a transformation of coördinates. *It is assumed in this definition that the equation in the new coördinates is not simplified by multiplying or dividing by a constant.* An expression involving the coördinates which remains unchanged when the equation in the new coördinates is simplified is called an *absolute invariant*. Hence, from (8),

* This quadratic may be regarded as a cubic equation with one infinite root, by a theorem analogous to Theorem IV, p. 15. The locus of (4) for $k = \infty$ is $x^2 + y^2 = 0$, which is one of the degenerate conics of the system.

Theorem III. *The discriminant Θ of an equation of the second degree is invariant under a rotation of the axes.*

Corollary. *The expression $\xi = 4AF + 4CF - E^2 - D^2$ is invariant under a rotation of the axes.*

Lemma IV. *An invariant of*

$$(9) \quad Ax^2 + Bxy + Cy^2 + F = 0$$

under a rotation of the axes which involves only A , B , and C is also an invariant of (2).

Proof. Substituting in (9) from (1), we obtain

$$A'x'^2 + B'x'y' + C'y'^2 + F = 0,$$

where A' , B' , and C' have the same values as in (3).

For when we substitute from (1) in $Ax^2 + Bxy + Cy^2$ we obtain only terms in x'^2 , $x'y'$, and y'^2 , and substituting in $Dx + Ey$ in (2) we obtain only terms in x' and y' .

Hence an expression involving only A , B , and C will be an invariant of (2) if it is an invariant of (9). Q.E.D.

Theorem IV. *The expressions*

$$\Delta = B^2 - 4AC, \quad H = A + C,$$

are invariants of an equation of the second degree under a rotation of the axes.

Proof. Consider the system

$$(10) \quad Ax^2 + Bxy + Cy^2 + F + k(x^2 + y^2) = 0.$$

Rotating the axes, this equation becomes

$$(11) \quad A'x'^2 + B'x'y' + C'y'^2 + F + k(x'^2 + y'^2) = 0.$$

Denote the discriminants of (10) and (11) by Θ_1 and Θ_1' . Then the locus of (10) is degenerate when and only when

$$\Theta_1 = 4(A + k)(C + k)F - FB^2 = 0$$

or

$$(12) \quad 4k^2 + 4(A + C)k - (B^2 - 4AC) = 0.$$

Similarly, the locus of (11) is degenerate when and only when

$$(13) \quad \Theta_1' = 4k^2 + 4(A' + C')k - (B'^2 - 4A'C') = 0.$$

Since (10) and (11) have the same locus, (12) and (13) have the same roots. And since the coefficients of k^2 in (12) and (13) are equal, the remaining coefficients are equal. Hence

$$B'^2 - 4A'C' = B^2 - 4AC$$

and

$$A' + C' = A + C.$$

Q.E.D.

Ex. 1. Transform $x^2 + xy + x - 2y + 4 = 0$ by rotating the axes through $\frac{\pi}{4}$. Compute Δ , H , and Θ for the given and required equations.

Solution. In the given equation

$$\begin{aligned} A &= 1, B = 1, C = 0, D = 1, E = -2, F = 4. \\ \therefore H &= 1 + 0 = 1, \Delta = 1^2 - 4 \cdot 1 \cdot 0 = 1, \\ \Theta &= 4 \cdot 1 \cdot 0 \cdot 4 + 1 \cdot 1(-2) - 1(-2)^2 - 0 \cdot 1^2 - 4 \cdot 1^2 = -10. \end{aligned}$$

To rotate the axes set (Theorem II, p. 162)

$$x = x' \cos \frac{\pi}{4} - y' \sin \frac{\pi}{4} = \frac{x' - y'}{\sqrt{2}}, \quad y = x' \sin \frac{\pi}{4} + y' \cos \frac{\pi}{4} = \frac{x' + y'}{\sqrt{2}}.$$

This gives, after removing parentheses but *not* clearing of fractions,

$$(14) \quad x'^2 - x'y' - \frac{1}{\sqrt{2}}x' - \frac{3}{\sqrt{2}}y' + 4 = 0.$$

$$\text{Here } A = 1, B = -1, C = 0, D = -\frac{1}{\sqrt{2}}, E = -\frac{3}{\sqrt{2}}, F = 4.$$

$$\therefore \Delta = 1, H = 1, \Theta = -10.$$

Hence the values of Δ , H , and Θ are unchanged.

But if we clear fractions in (14) we obtain

$$\sqrt{2}x'^2 - \sqrt{2}x'y' - x' - 3y' + 4\sqrt{2} = 0.$$

$$\text{For this equation } \Delta = 2, H = \sqrt{2}, \Theta = -20\sqrt{2}.$$

Hence Δ , H , and Θ are not *absolute* invariants under a rotation of the axes.

Theorem V. The expressions $\frac{H^2}{\Delta}$ and $\frac{H^3}{\Theta}$ are absolute invariants of an equation of the second degree under a rotation of the axes.*

Proof. The given expressions are invariants because Δ , H , and Θ are invariants. To show that they are *absolute* invariants we must prove that their values are unchanged when we multiply

$$(15) \quad Ax^2 + Bxy + Cy^2 + Dx + Ey + F = 0$$

by a constant. Multiplying (15) by k , we get

$$(16) \quad kAx^2 + kBxy + kCy^2 + kDx + kEy + kF = 0.$$

Denote the invariants of (16) by Δ_k , H_k , and Θ_k . Then

$$(17) \quad \Delta_k = k^2B^2 - 4kAkC = k^2(B^2 - 4AC) = k^2\Delta.$$

$$(18) \quad H_k = kA + kC = k(A + C) = kH.$$

$$(19) \quad \Theta_k = k^3(4ACF + BDE - AE^2 - CD^2 - FB^2) = k^3\Theta.$$

*The proof also holds for a translation of the axes after Theorems VI and VII are proved.

Dividing the square of (18) by (17),

$$\frac{H_k^2}{\Delta_k} = \frac{H^2}{\Delta}$$

Dividing the cube of (18) by (19),

$$\frac{H_k^3}{\Theta_k} = \frac{H^3}{\Theta}$$

Hence $\frac{H^2}{\Delta}$ and $\frac{H^3}{\Theta}$ are absolute invariants.

Q. E. D.

PROBLEMS

1. Compute $\frac{H^2}{\Delta}$ and $\frac{H^3}{\Theta}$ for the equations in problem 2, p. 168, and also for their answers.

2. The values of A' , B' , and C' in (3), p. 270, are respectively the coefficients of x'^2 , $x'y'$, and y'^2 in (4), p. 170. Compute the values of $B'^2 - 4A'C'$ and $A' + C'$ in terms of A , B , and C .

3. Show that $\frac{C}{\pm\sqrt{A^2 + B^2}}$ is an invariant of the line $Ax + By + C = 0$ under a rotation of the axes.

4. Show that $\frac{Ax_1 + By_1 + C}{\pm\sqrt{A^2 + B^2}}$ is an invariant of the line $Ax + By + C = 0$ and the point $P_1(x_1, y_1)$ under a rotation of the axes.

5. Show that $\sqrt{(x_1 - x_2)^2 + (y_1 - y_2)^2}$ is an invariant of the points $P_1(x_1, y_1)$ and $P_2(x_2, y_2)$ under a rotation of the axes.

6. Show that $\frac{A_2B_1 - A_1B_2}{A_1A_2 + B_1B_2}$ is an invariant of the lines $A_1x + B_1y + C_1 = 0$ and $A_2x + B_2y + C_2 = 0$ under a rotation of the axes.

7. Interpret geometrically the meaning of the invariants in problems 3 to 6.

108. Invariants under a translation of the axes.

Theorem VI. *The expressions*

$$\Delta = B^2 - 4AC, \quad H = A + C$$

are invariants of an equation of the second degree under a translation of the axes.

Proof. If an equation of the second degree be transformed by translating the axes, the coefficients A , B , and C are unchanged (Corollary I, p. 171). Hence any expression involving these letters, as Δ or H , is an invariant. Q. E. D.

Lemma V. *If the axes are translated to the point (h, k) , then for any point P whose old and new coördinates are respectively (x, y) and (x', y') we have*

$$kx - hy = kx' - hy'.$$

Proof. To translate the axes we set (Theorem I, p. 160)

$$x = x' + h, \quad y = y' + k.$$

$$\begin{aligned} \text{Then} \quad kx - hy &= k(x' + h) - h(y' + k) \\ &= kx' - hy'. \end{aligned}$$

Q. E. D.

The Lemma is evident geometrically since either $kx - hy$ or $kx' - hy'$ is the area of the triangle whose vertices are P and the old and new origins [(VIII), p. 42].

Theorem VII. *The discriminant Θ of the equation*

$$(1) \quad Ax^2 + Bxy + Cy^2 + Dx + Ey + F = 0$$

is an invariant under a translation of the axes

$$(2) \quad x = x' + h, \quad y = y' + k.$$

Proof. Consider the system

$$(3) \quad Ax^2 + Bxy + Cy^2 + Dx + Ey + F + k'(kx - hy) = 0.$$

Substituting in (3) from (2), we obtain

$$(4) \quad Ax'^2 + Bx'y' + Cy'^2 + D'x' + E'y' + F' + k'(kx' - hy') = 0.$$

For (1) becomes an equation of the form (Corollary I, p. 171)

$$(5) \quad Ax'^2 + Bx'y' + Cy'^2 + D'x' + E'y' + F' = 0,$$

and $kx - hy$ becomes $kx' - hy'$ (Lemma V).

Denote the discriminants of (1) and (5) by Θ and Θ' ; of (3) and (4) by Θ_1 and Θ_1' . If the locus of (3) is degenerate (Theorem I, p. 266),

$$\Theta_1 = 4ACF + B(D + k'k)(E - k'h) - A(E - k'h)^2 - C(D + k'k)^2 - FB^2 = 0,$$

or

$$(6) \quad (Bhk - Ah^2 - Ck^2)k'^2 + (BEk - BDh + 2AEh - 2CDk)k' + \Theta = 0.$$

Similarly, the locus of (4) is degenerate if

$$(7) \quad (Bhk - Ah^2 - Ck^2)k'^2 + (BE'k - BD'h + 2AE'h - 2CD'k)k' + \Theta' = 0.$$

Since (6) and (7) must have the same roots, and since the coefficients of k'^2 are equal, then the remaining coefficients are equal. Hence

$$\Theta' = \Theta.$$

Q. E. D.

Since any transformation of coördinates may be effected by a rotation and a translation of the axes, the results of Theorems III, IV, VI, and VII may be embodied in a single theorem.

Theorem VIII. *If the equation*

$$Ax^2 + Bxy + Cy^2 + Dx + Ey + F = 0$$

be transformed by a transformation of coördinates into

$$A'x'^2 + B'x'y' + C'y'^2 + D'x' + E'y' + F' = 0,$$

then

$$\Delta' = B'^2 - 4A'C' = B^2 - 4AC = \Delta,$$

$$H' = A' + C' = A + C = H,$$

and

$$\Theta' = 4A'C'F' + B'D'E' - A'E'^2 - C'D'^2 - F'B'^2 \\ = 4ACF + BDE - AE^2 - CD^2 - FB^2 = \Theta.$$

That is, Δ , H , and Θ are invariants of an equation of the second degree under any transformation of coördinates.

PROBLEMS

1. Compute $\frac{H^2}{\Delta}$ and $\frac{H^3}{\Theta}$ for the equations in problem 1, p. 168, and the answers.

2. Prove that the expressions in problems 4 to 6, p. 273, are invariant under a translation of the axes and interpret them geometrically.

3. Prove by direct substitution that ξ (Corollary, p. 271) is invariant under a translation of the axes provided that $\Delta = \Theta = 0$.

109. Nature of the locus of an equation of the second degree. By a transformation of coördinates the equation

$$(1) \quad Ax^2 + Bxy + Cy^2 + Dx + Ey + F = 0$$

may be reduced* to one of the forms (Theorem XIII, p. 196)

- (I) $A'x'^2 + C'y'^2 + F' = 0$, where $A' \neq 0$ and $C' \neq 0$;
- (II) $C'y'^2 + D'x' = 0$, where $C' \neq 0$ and $D' \neq 0$;
- (III) $C'y'^2 + F' = 0$, where $C' \neq 0$.

The theory of invariants enables us to determine to which one of these three forms a *given* equation may be reduced and to find the *exact nature* of the locus without actually effecting the transformation of coördinates.

To do this compute the numerical values of Δ , H , and Θ for the given equation (1). We have, further,

- (2) for (I), $\Delta' = -4A'C' \neq 0$, $H' = A' + C'$, $\Theta' = 4A'C'F'$;
- (3) for (II), $\Delta' = 0$, $H' = C' \neq 0$, $\Theta' = -C'D'^2 \neq 0$;
- (4) for (III), $\Delta' = 0$, $H' = C' \neq 0$, $\Theta' = 0$.

But in each case, by Theorem VIII,

$$(5) \quad \Delta' = \Delta, \quad H' = H, \quad \Theta' = \Theta.$$

* It is assumed that the equation is not multiplied or divided by a constant in this reduction.

Hence, if $\Delta \neq 0$, (1) may be reduced to the form (I);

if $\Delta = 0$ and $\Theta \neq 0$, (1) may be reduced to the form (II);

and if $\Delta = 0$ and $\Theta = 0$, (1) may be reduced to the form (III).

We shall discuss these three cases separately.

CASE I. $\Delta \neq 0$. Substituting from (2) in (5), we get

$$(6) \quad -4A'C' = \Delta,$$

$$(7) \quad A' + C' = H,$$

$$(8) \quad 4A'C'F' = \Theta.$$

Elliptic type, $\Delta < 0$.

From (6), if $\Delta < 0$, A' and C' have the same signs and the locus belongs to the elliptic type (p. 195).

From (8), if $\Theta \neq 0$, then $F' \neq 0$ and the locus is an *ellipse* if H and Θ differ in sign, or there is *no locus* if H and Θ agree in sign. For A' and C' have the sign of H , from (7), and F' has the sign of Θ , from (8).

From (8), if $\Theta = 0$, then $F' = 0$ and the locus is a *point*.

The values of A' , C' , and F' , if desired, may be found by solving (6), (7), and (8).

CASE II. $\Delta = 0$ and $\Theta \neq 0$. The locus is a parabola (p. 180).

Substituting from (3) in (5), we get $C' = H$ and $-C'D'^2 = \Theta$, from which the values of C' and D' may be found if desired.

CASE III. $\Delta = 0$ and $\Theta = 0$. Substituting from (4) in (5), we obtain the single equation $C' = H$, which does not enable us to compare the signs of C' and F' in (III). But $\xi = 4AF + 4CF - E^2 - D^2$ is invariant under a rotation of the axes, and when $\Delta = \Theta = 0$, ξ is also an invariant under a translation of the axes.

For, substituting the values of D' , E' , and F' given by (5), p. 170, and setting $A' = A$, $B' = B$, $C' = C$ (Corollary I, p. 171) in

$$\xi' = 4A'F' + 4C'F' - E'^2 - D'^2,$$

we get

$$\xi' = (4CD - 2BE)h + (4AE - 2BD)k + \xi.$$

But if $\Delta = \Theta = 0$, then $2BD - 4AE = 0$, from (6), p. 265. Multiplying this by B and setting $B^2 = 4AC$ (from $\Delta = 0$), we have $4ACD - 2ABE = 0$, or $4CD - 2BE = 0$. Hence $\xi' = \xi$.

For (III) we have $\xi' = 4C'F'$, and hence

$$4C'F' = \xi.$$

Hence (p. 196) if $\xi < 0$, the locus is two parallel lines;

if $\xi = 0$, the locus is a single line;

if $\xi > 0$, there is no locus.

The results of this section are embodied in

Theorem IX. *The nature of the locus of the equation*

$$Ax^2 + Bxy + Cy^2 + Dx + Ey + F = 0$$

depends upon the values of the invariants

$$\Delta = B^2 - 4AC, \quad H = A + C,$$

$$\Theta = 4ACF + BDE - AE^2 - CD^2 - FB^2,$$

and
$$\xi = 4AF + 4CF - E^2 - D^2,$$

as indicated in the following table.

$\Theta \neq 0$ Conic.	$\Delta < 0$	Ellipse, if H and Θ differ in sign. No locus, if H and Θ agree in sign.
	$\Delta = 0$	Parabola.
	$\Delta > 0$	Hyperbola.
$\Theta = 0$ Degenerate Conic.	$\Delta < 0$	Point.
	$\Delta = 0$	Two parallel lines, if $\xi < 0$. One line, if $\xi = 0$. No locus, if $\xi > 0$.
	$\Delta > 0$	Two intersecting lines.

PROBLEMS

1. Find the exact nature of the locus of

- | | |
|-------------------------------------------------|--------------------------|
| (a) $x^2 + 2xy + 2y^2 - 6x - 2y + 9 = 0$. | Ans. Ellipse. |
| (b) $x^2 - 2xy + 2y^2 - 4y + 8 = 0$. | Ans. No locus. |
| (c) $x^2 + 6xy + 9y^2 + 2x - 6y = 0$. | Ans. Parabola. |
| (d) $x^2 - 2xy - y^2 + 8x - 6 = 0$. | Ans. Hyperbola. |
| (e) $4x^2 + 9y^2 + 4x + 1 = 0$. | Ans. Point. |
| (f) $4x^2 + 4xy + y^2 + 4x + 2y - 48 = 0$. | Ans. Two parallel lines. |
| (g) $4x^2 - 20xy + 25y^2 + 12x - 30y + 9 = 0$. | Ans. One line. |
| (h) $9x^2 - 12xy + 4y^2 - 18x + 12y + 34 = 0$. | Ans. No locus. |
| (i) $3x^2 - 10xy + 7y^2 + 15x - 7y - 42 = 0$. | Ans. Intersecting lines. |

2. Find a^2 and b^2 , or p , for the following conics :

- | | |
|-------------------------------------------|---------------------------|
| (a) $x^2 - 2xy + y^2 - 8x = 0$. | Ans. $p = \sqrt{2}$. |
| (b) $3x^2 - 10xy + 3y^2 - 8 = 0$. | Ans. $a^2 = 1, b^2 = 4$. |
| (c) $5x^2 + 2xy + 5y^2 - 12x - 12y = 0$. | Ans. $a^2 = 3, b^2 = 2$. |

Hint. Compute the absolute invariants $\frac{H^2}{\Delta}$ and $\frac{H^3}{\Theta}$ for the given equation and for that one of the typical forms (III), p. 179, (V) and (VI), p. 185, to which it may be reduced. Equate and solve for a^2 and b^2 or for p .

3. Show that A' and C' in (I), p. 275, are the roots of the quadratic $4x^2 - 4Hx - \Delta = 0$ and show that they are always real. When will they also be equal?

110. Equal conics. The object of this section is to determine when two conics whose equations are given are equal. The solution of this problem affords a further application of the theory of invariants.

Theorem X. *The axes of a non-degenerate central conic whose equation is*

$$Ax^2 + Bxy + Cy^2 + Dx + Ey + F = 0$$

are determined by the values of the absolute invariants $\frac{H^2}{\Delta}$ and $\frac{H^3}{\Theta}$.

Proof. The equation of a central conic may be reduced to the form [(11), p. 187]

$$\frac{x^2}{\alpha} + \frac{y^2}{\beta} = 1.$$

The absolute invariants of this equation are

$$\frac{H^2}{\Delta'} = \frac{\left(\frac{1}{\alpha} + \frac{1}{\beta}\right)^2}{-4} = \frac{(\alpha + \beta)^2}{-4\alpha\beta}, \quad \frac{H^3}{\Theta'} = \frac{\left(\frac{1}{\alpha} + \frac{1}{\beta}\right)^3}{-4} = \frac{(\alpha + \beta)^3}{-4\alpha^2\beta^2}.$$

Hence (Theorem VIII, p. 275)

$$(1) \quad \frac{(\alpha + \beta)^2}{-4\alpha\beta} = \frac{H^2}{\Delta}, \quad \frac{(\alpha + \beta)^3}{-4\alpha^2\beta^2} = \frac{H^3}{\Theta},$$

where $\frac{H^2}{\Delta}$ and $\frac{H^3}{\Theta}$ are known. These equations can be solved for α and β , and the values of the axes determined from them by 1 and 2, p. 187, and the definition of the axes (p. 185). Q. E. D.

Equations (1) may be solved as follows:

Dividing the second by the first,

$$(2) \quad \frac{\alpha + \beta}{\alpha\beta} = \frac{\Delta H}{\Theta}.$$

Dividing the first of equations (1) by (2),

$$(3) \quad \alpha + \beta = -\frac{4H\Theta}{\Delta^2}.$$

Dividing (3) by (2),

$$\alpha\beta = -\frac{4\Theta^2}{\Delta^3}.$$

Then, by Theorem I, p. 3, α and β are the roots of the quadratic equation

$$(4) \quad x^2 + \frac{4H\Theta}{\Delta^2}x - \frac{4\Theta^2}{\Delta^3} = 0, \quad \text{or} \quad \Delta^3x^2 + 4\Delta H\Theta x - 4\Theta^2 = 0.$$

The roots of (4) are always real, for the discriminant is

$$\begin{aligned} (4\Delta H\Theta)^2 - 4\Delta^3(-4\Theta^2) &= 16\Delta^2\Theta^2(H^2 + \Delta) \\ &= 16\Delta^2\Theta^2(A^2 + 2AC + C^2 + B^2 - 4AC) \\ &= 16\Delta^2\Theta^2[(A - C)^2 + B^2], \end{aligned}$$

which is always positive when the coefficients A, B, C, D, E , and F are real numbers.

Theorem XI. *The value of p for a parabola whose equation is*

$$Ax^2 + Bxy + Cy^2 + Dx + Ey + F = 0$$

is determined by the value of the absolute invariant $\frac{H^3}{\Theta}$.

Proof. For the parabola

$$y^2 = 2px$$

we have

$$\frac{H^3}{\Theta'} = \frac{1^3}{-4p^2} = -\frac{1}{4p^2}.$$

Hence (Theorem VIII)

$$-\frac{1}{4p^2} = \frac{H^3}{\Theta},$$

whence

$$p = \frac{1}{2} \sqrt{-\frac{\Theta}{H^3}}.$$

Q. E. D.

As the value of p is always a real number, Θ and H must have opposite signs. This may also be proved from the values of Θ and H by means of the condition $\Delta = 0$.

Theorem XII. *Two non-degenerate conics*

$$C : Ax^2 + Bxy + Cy^2 + Dx + Ey + F = 0$$

and

$$C' : A'x^2 + B'xy + C'y^2 + D'x + E'y + F' = 0$$

are equal when and only when

$$\frac{H'^2}{\Delta'} = \frac{H^2}{\Delta}, \quad \frac{H'^3}{\Theta'} = \frac{H^3}{\Theta}.$$

Proof. If the conics are central conics, they are equal when and only when their axes are equal. But the axes of C and C' are determined in the same

manner from $\frac{H^2}{\Delta}$ and $\frac{H^3}{\Theta}$ and from $\frac{H'^2}{\Delta'}$ and $\frac{H'^3}{\Theta'}$ respectively (Theorem X).

Hence the axes are equal when and only when

$$\frac{H'^2}{\Delta'} = \frac{H^2}{\Delta} \quad \text{and} \quad \frac{H'^3}{\Theta'} = \frac{H^3}{\Theta}.$$

If C and C' are parabolas, they are equal when and only when they have the same value of p , that is (Theorem XI), when and only when

$$\frac{H'^3}{\Theta'} = \frac{H^3}{\Theta}.$$

Q. E. D.

111. Conics determined by five conditions. The equation of any conic has the form

$$(1) \quad Ax^2 + Bxy + Cy^2 + Dx + Ey + F = 0,$$

and the conic is completely determined if five of the coefficients are known in terms of the sixth. Any geometrical condition which the curve must satisfy gives rise to an equation between one or more of the coefficients. Hence five conditions will determine the equation of a conic. The locus may be degenerate, or there may be no locus, which would mean that the five conditions are inconsistent.

Rule to determine the equation of a conic which satisfies five conditions.

First step. Assume that the equation of the conic is

$$Ax^2 + Bxy + Cy^2 + Dx + Ey + F = 0.$$

Second step. Find five equations between the coefficients, each of which expresses that the conic satisfies one of the given conditions.

Third step. Solve these equations for five of the coefficients in terms of the sixth.

Fourth step. Substitute the results of the third step in the equation in the first step and divide out the remaining coefficient. The result is the required equation.

PROBLEMS

1. Show that the following pairs of conics are equal and determine the nature of the conics.

(a) $x^2 - 4y^2 - 2x - 16y - 14 = 0$, $3x^2 + 10xy + 3y^2 - 2 = 0$.

(b) $9x^2 + 24xy + 16y^2 - 80x + 60y = 0$, $x^2 - 2xy + y^2 - 4\sqrt{2}x - 4\sqrt{2}y = 0$.

(c) $x^2 + y^2 - 2x - 8y - 8 = 0$, $x^2 + y^2 + 6x - 10y + 9 = 0$.

(d) $2x^2 + y^2 - 12x + 10y + 41 = 0$, $17x^2 - 12xy + 22y^2 - 26 = 0$.

2. Find the equations of the conics determined by the following conditions and determine the nature of the conic in each case.

(a) Passing through $(0, 0)$, $(2, 0)$, $(0, 2)$, $(4, 2)$, $(2, 4)$.

Ans. $x^2 - xy + y^2 - 2x - 2y = 0$.

(b) Passing through $(0, 0)$, $(10, 0)$, $(5, 3)$ and symmetrical to the X -axis.

Ans. $9x^2 + 25y^2 - 90x = 0$.

(c) Passing through $(-4, 0)$, $(0, 4)$, $(0, -4)$, $(5, 6)$ if $\Delta = 0$.

Ans. $y^2 - 4x - 16 = 0$.

(d) Passing through $(0, 5)$, $(5, 0)$ and symmetrical with respect to both axes.

Ans. $x^2 + y^2 - 25 = 0$.

(e) Passing through $(0, 0)$, $(2, 1)$, $(-2, 4)$, $(-4, -2)$, $(2, -4)$.

Ans. $2x^2 - 3xy - 2y^2 = 0$.

(f) Passing through $(0, 2)$, $(-2, 0)$, $(2, -8)$ and symmetrical with respect to the origin.

Ans. $x^2 + 4xy + y^2 - 4 = 0$.

3. Show that, in general, two parabolas may be constructed which pass through four given points.

4. Find the parabolas passing through the following points and construct the figures.

(a) $(0, 2)$, $(0, -2)$, $(4, 0)$, $(-1, 0)$. *Ans.* $x^2 \pm 2xy + y^2 - 3x - 4 = 0$.

(b) $(2, 0)$, $(0, -8)$, $(-2, 0)$, $(0, 2)$.

Ans. $4x^2 \pm 4xy + y^2 + 6y - 16 = 0$.

(c) $(0, 1)$, $(0, -\frac{1}{2})$, $(2, 0)$, $(-1, 0)$.

Ans. $x^2 \pm 4xy + 4y^2 - x - 2y - 2 = 0$.

CHAPTER XIII

EUCLIDEAN TRANSFORMATIONS WITH AN APPLICATION TO SIMILAR CONICS

112. An operation which replaces a given figure by a second figure in accordance with a given law is called a **transformation**. If a transformation replaces the points of one figure by the points of a second, it is called a **point transformation**. If a point transformation replaces $P(x, y)$ by $P'(x', y')$, then the equations expressing x' and y' in terms of x and y , or conversely, are called the **equations of the transformation**. In this chapter we shall consider the transformations which replace a given figure by one equal or similar to it. They are called **Euclidean transformations**, because the properties of equal and similar figures are studied in the Elementary Geometry of Euclid.

113. Equal figures. Two figures whose corresponding lines and angles are equal may be brought into coincidence and are therefore equal. Equal figures in the same plane are said to be **congruent** if the corresponding parts are arranged in the same order, and **symmetrical** if they are arranged in the opposite order. Thus the triangles ABC and $A'B'C'$ are congruent, and either is symmetrical to $A''B''C''$, because the

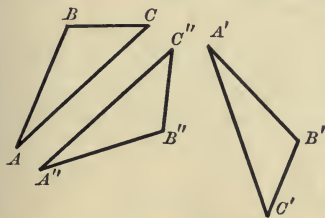

directions established on the perimeters by the corresponding vertices are the same (clockwise) in the first case but are different in the second case.

directions established on the perimeters by the corresponding vertices are the same (clockwise) in the first case but are different in the second case.

In Plane Geometry we do not study symmetrical figures as such. It is true that we study figures which are symmetrical with respect to a point or with respect to a line. But it should be noticed, as is seen from the figures, that figures which are symmetrical with respect to a *point* are *congruent*, while figures which are symmetrical with respect to a *line* are *symmetrical* in the sense defined above.

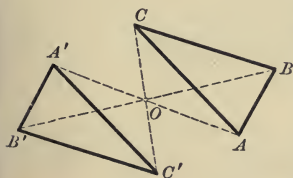

The essential distinction between congruent and symmetrical figures is this: two congruent figures may be brought into coincidence by *moving them around in the plane*, but before two symmetrical figures can be

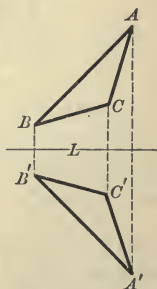

brought into coincidence one of them *must be taken out of the plane and turned over*.

114. Translations. A translation is the transformation which moves all points of a figure through the same distance in the same direction. Hence if a translation replaces any point P by P' , the projections of PP' on the axes will be constant.

Theorem I. *The equations of a translation through the directed length whose projections on the axes are respectively h and k are*

$$(I) \quad \begin{cases} x' = x + h, \\ y' = y + k. \end{cases}$$

Proof. By Theorem III, p. 31, the projections of PP' on the axes are respectively

$$x' - x, \quad y' - y.$$

Then, by hypothesis,

$$x' - x = h, \quad y' - y = k.$$

Solving for x' and y' , we obtain (I). Q.E.D.

If we solve (I) for x and y and substitute their values in the equation of a curve, the result will evidently be the equation of the curve after it has been translated.

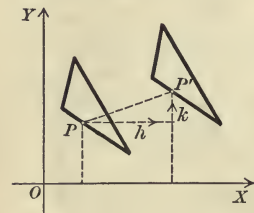

If P is the origin $(0, 0)$, then P' is the point (h, k) . If we solve (I) for x and y , we obtain

$$x = x' - h, \quad y = y' - k.$$

These may be regarded as the equations for translating the axes to a new origin $(-h, -k)$ (Theorem I, p. 160).

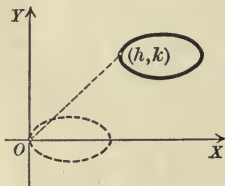

(1)

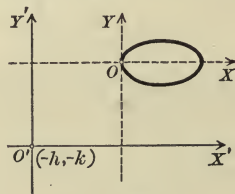

(2)

It is evident that the relative position of the new figure and the old axes (Fig. 1) is the same as that of the old figure and the new axes (Fig. 2).

Hence it is immaterial whether we regard equations (I) as the equations of a translation of a figure in one direction or as the equations of a translation of the axes in the opposite direction.

115. Rotations. The transformation which turns all points through the same angle about a given point O is called a rotation. O is called the center of the rotation. If a rotation replaces P by P' , then $OP' = OP$.

Theorem II. *The equations of a rotation about the origin through an angle θ are*

$$(II) \quad \begin{cases} x' = x \cos \theta - y \sin \theta, \\ y' = x \sin \theta + y \cos \theta. \end{cases}$$

Proof. Let the polar coordinates of P be (ρ, ϕ) . Then, by definition, those of P' are $(\rho, \phi + \theta)$. Hence (Theorem I, p. 155)

$$\begin{aligned} x' &= \rho \cos(\phi + \theta) \\ &= \rho \cos \phi \cos \theta - \rho \sin \phi \sin \theta \\ &\qquad\qquad\qquad (\text{by 10, p. 20}) \\ &= x \cos \theta - y \sin \theta, \end{aligned}$$

since [(I), p. 155]

$$x = \rho \cos \phi, \quad y = \rho \sin \phi.$$

Similarly,

$$y' = x \sin \theta + y \cos \theta. \quad \text{Q.E.D.}$$

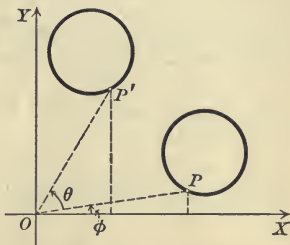

If we solve (II) for x and y , we get

$$x = x' \cos \theta + y' \sin \theta = x' \cos(-\theta) - y' \sin(-\theta), \quad (\text{by 4, p. 19})$$

$$y = -x' \sin \theta + y' \cos \theta = x' \sin(-\theta) + y' \cos(-\theta). \quad (\text{by 4, p. 19})$$

These may be regarded (Theorem II, p. 162) as the equations for rotating the axes through an angle $-\theta$. Hence it is immaterial whether we regard equations (II) as the equations of a rotation of a figure in one direction or of the axes in the opposite direction. This should be illustrated by figures analogous to Figs. 1 and 2, p. 282.

PROBLEMS

1. Plot the following curves, translate them through the directed length whose projections are given, and find the equations of the curves in their new positions.

(a) $y^2 = 4x, h = -3, k = 2.$ *Ans.* $y^2 - 4x - 4y - 8 = 0.$

(b) $xy = 6, h = 2, k = -2.$ *Ans.* $xy + 2x - 2y - 2 = 0.$

(c) $x^2 + 9y^2 = 25, h = 0, k = \frac{5}{3}.$ *Ans.* $x^2 + 9y^2 - 30y = 0.$

2. Plot the following curves, rotate them about the origin through the given angle, and find the equations of the curves in their new positions.

(a) $xy = 8, \theta = \frac{\pi}{4}.$ *Ans.* $y^2 - x^2 = 16.$

(b) $x^2 + y^2 - 8x + 12 = 0, \theta = \pi.$ *Ans.* $x^2 + y^2 + 8x + 12 = 0.$

(c) $x^2 + 4y^2 - 18x = 0, \theta = -\frac{\pi}{2}.$ *Ans.* $4x^2 + y^2 + 18y = 0.$

3. Translate the locus of $x^2 + 4y = 0$ through a distance whose projections are $h = 0$, $k = -4$ and then rotate it about the origin through an angle of $\frac{\pi}{2}$. *Ans.* $y^2 - 4x + 16 = 0$.

4. Rotate the curve in problem 3 through the given angle and then translate it. *Ans.* $y^2 - 4x + 8y + 16 = 0$.

5. Prove from equations (II) that the origin is unchanged by a rotation, that is, that the origin is a fixed point.

6. Find the equations of the straight lines which are unchanged by the translation (I).

Hint. Translate $Ax + By + C = 0$ and then determine A , B , and C so that this line coincides with the line into which it is translated by Theorem III, p. 88.

$$\text{Ans. } kx - hy = 0.$$

7. Find the equations of all circles which are unchanged by the rotation (II). *Ans.* $x^2 + y^2 + F = 0$.

8. Show that no straight lines are invariant under the rotation (II).

Hint. See the hint, problem 6, and apply Theorem IV, p. 90.

9. Prove analytically that no points are unchanged by a translation unless all points are unchanged.

116. Displacements. A transformation which replaces any figure by one congruent to it (p. 281) is called a **displacement**. Hence a figure is displaced when it is moved in the plane from one position to another. This may evidently be accomplished in many different ways. Two displacements which move a figure from one position to the same second position are said to be **equivalent**.

Lemma I. *A displacement is equivalent to a translation or to a rotation followed by a translation.*

Proof. Let the given displacement replace any figure F by a figure F' . Then if corresponding lines in F and F' are parallel and have the same direction, F may be translated into F' , and hence the displacement is equivalent to a translation.

If this is not the case, then F may be rotated into a position F'' such that corresponding lines in F'' and F' are parallel and have the same direction and then F'' may be translated into F' . Hence the given displacement is equivalent to a rotation followed by a translation.

Theorem III. *The equations of any displacement have the form*

$$(III) \quad \begin{cases} x' = x \cos \theta - y \sin \theta + h, \\ y' = x \sin \theta + y \cos \theta + k, \end{cases}$$

where θ , h , and k are arbitrary constants.

Proof. Let the given displacement replace any figure F by a congruent figure F' . Then by Lemma I it is equivalent to a translation whose equations have the form (III) when $\theta = 0$ (Theorem I, p. 282), or to a rotation which replaces F by a figure F'' followed by a translation which replaces F'' by F' .

By Theorem II,

$$x'' = x \cos \theta - y \sin \theta, \quad y'' = x \sin \theta + y \cos \theta,$$

and by Theorem I, $x' = x'' + h, \quad y' = y'' + k.$

Substituting the values of x'' and y'' in these equations, we obtain (III).

Q. E. D.

If a point is unchanged by a transformation, it is called a **fixed** or an **invariant point**. Thus the center of a rotation is an invariant point.

Theorem IV. *If a displacement is not equivalent to a translation, there is one fixed point.*

Proof. The point (x, y) will be a fixed point when and only when $x' = x$ and $y' = y$. Substituting in (III) and transposing, we get

$$(1) \quad \begin{cases} (1 - \cos \theta)x + \sin \theta \cdot y = h, \\ -\sin \theta \cdot x + (1 - \cos \theta)y = k, \end{cases}$$

These equations can be solved, in general, for one pair of values of x and y (Theorem IV, p. 90), and hence there will be, in general, but one fixed point.

But if
$$\frac{1 - \cos \theta}{-\sin \theta} = \frac{\sin \theta}{1 - \cos \theta},$$

or, reducing,

$$\cos \theta = 1,$$

there will be no solution, that is, there is no fixed point. If $\cos \theta = 1$, then $\sin \theta = 0$ (by 3, p. 19) and equations (III) become

$$x' = x + h, \quad y' = y + k,$$

which are the equations of a translation.

Hence there is one fixed point unless the displacement is a translation.

Q. E. D.

There cannot be an infinite number of solutions of (1) unless $h = k = 0$. For if

$$\frac{1 - \cos \theta}{-\sin \theta} = \frac{\sin \theta}{1 - \cos \theta} = \frac{h}{k},$$

then, as above, $\cos \theta = 1$ and $\sin \theta = 0$. Substituting in (1), we get $h = 0$ and $k = 0$. In this case every point (x, y) is a fixed point, that is, there is no displacement.

Theorem V. *Every displacement which is not equivalent to a translation is equivalent to a rotation.*

Proof. If the displacement is not equivalent to a translation, then it has a fixed point (Theorem IV). Let the fixed point be chosen as origin. Then if $x = 0$ and $y = 0$, we get $x' = 0$ and $y' = 0$. Substituting in (III), we obtain

$$h = 0, \quad k = 0$$

as the conditions that the origin is the fixed point. For these values of h and k equations (III) reduce to (II), p. 283, and hence the displacement is equivalent to a rotation. Q. E. D.

Corollary I. *Any two congruent figures may be brought into coincidence by a rotation or a translation.*

Corollary II. *The perpendicular bisectors of the lines joining corresponding points of two congruent figures pass through the same point or are parallel.*

For if the figures may be brought into coincidence by a rotation, they pass through the center of the rotation; and if the figures may be brought into coincidence by a translation, they are perpendicular to the direction of the translation.

PROBLEMS

1. Show analytically that the angle between two lines is unchanged by a displacement.

Hint. Show that the value of $\tan \theta$ given by (X), p. 109, is an absolute invariant of the displacement (III).

2. Show analytically that the distance between two points is unchanged by a displacement.

Hint. Show that the value of l given by (IV), p. 31, is an absolute invariant of (III).

3. Prove Corollary II geometrically and derive Theorem V from it.

4. Show that a rotation about the origin through an angle of π replaces any figure by the figure symmetrical to it with respect to the origin.

5. Find the equations of a rotation about the point $(1, 4)$ through an angle of $\frac{\pi}{6}$. *Ans.* $x' = \frac{1}{2}\sqrt{3}x - \frac{1}{2}y + 3 - \frac{1}{2}\sqrt{3}$, $y' = \frac{1}{2}x + \frac{1}{2}\sqrt{3}y + \frac{7}{2} - 2\sqrt{3}$.

6. Find the equations of a rotation about the point $(3, -2)$ through an angle of $\frac{3\pi}{2}$. *Ans.* $x' = y + 5$, $y' = -x + 1$.

7. Find the equations of a rotation about the point (x_1, y_1) through an angle θ . *Ans.* $x' = (x - x_1)\cos \theta - (y - y_1)\sin \theta + x_1$,
 $y' = (x - x_1)\sin \theta + (y - y_1)\cos \theta + y_1$.

117. The reflection in a line. A transformation which replaces any figure by one symmetrical to it (p. 281) is called a *symmetry transformation*. The simplest symmetry transformation is the reflection in a line, which replaces a point by the point symmetrical to it with respect to that line. Hence a reflection in a line replaces a figure by the figure which is symmetrical to it with respect to that line.

Theorem VI. *The equations of a reflection in the X-axis are*

$$(VI) \quad \begin{cases} x' = x, \\ y' = -y. \end{cases}$$

118. Symmetry transformations.

Lemma II. *A symmetry transformation is equivalent to a reflection in any line followed by a displacement.*

Proof. Let the given transformation replace a figure F by a symmetrical figure F' . Let F be transformed into a figure F'' by a reflection in any line. Then since F' and F'' are both symmetrical to F , they are congruent to each other.

For the parts of F' and F'' are equal, since they are equal to the parts of F , and they are arranged in the same order, for they are in each case arranged in the opposite order to those of F .

Hence F'' can be brought into coincidence with F' by a displacement, that is, F may be transformed into F' by a reflection in any line followed by a displacement. Q. E. D.

Theorem VII. *The equations of any symmetry transformation have the form*

$$(VII) \quad \begin{cases} x' = x \cos \theta + y \sin \theta + h, \\ y' = x \sin \theta - y \cos \theta + k, \end{cases}$$

where θ , h , and k are arbitrary constants.

Proof. Let the given transformation replace any figure F by a symmetrical figure F' . Then by Lemma II it is equivalent to a reflection in the X-axis which replaces F by a figure F'' , followed by a displacement which replaces F'' by F' .

$$\text{By (VI),} \quad x'' = x, \quad y'' = -y,$$

and by (III), p. 285,

$$x' = x'' \cos \theta - y'' \sin \theta + h, \quad y' = x'' \sin \theta + y'' \cos \theta + k.$$

Substituting the values of x'' and y'' in these equations, we get (VII).

Q. E. D.

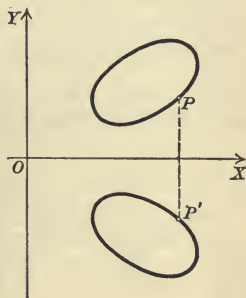

Theorem VIII. *The line whose equation is*

$$x \cos \omega + y \sin \omega - p = 0$$

is transformed by (VII) into the line whose equation is

$$x \cos (\theta - \omega) + y \sin (\theta - \omega) - [p + h \cos (\theta - \omega) + k \sin (\theta - \omega)] = 0.$$

This is proved by solving (VII) for x and y , substituting in the given equation, simplifying by 9 and 11, p. 20, and dropping primes.

A line is said to be **invariant** under a transformation if it is transformed into itself by that transformation.

Theorem IX. *There is always one line which is invariant under the symmetry transformation (VII), and if*

$$h \cos \frac{1}{2} \theta + k \sin \frac{1}{2} \theta = 0,$$

then all of the lines perpendicular to that line are invariant.

Proof. If the lines in Theorem VIII coincide, then (Theorem III, p. 88)

$$(1) \quad \frac{\cos \omega}{\cos (\theta - \omega)} = \frac{\sin \omega}{\sin (\theta - \omega)} = \frac{p}{p + h \cos (\theta - \omega) + k \sin (\theta - \omega)}.$$

From the first two ratios

$$\sin (\theta - \omega) \cos \omega - \cos (\theta - \omega) \sin \omega = 0,$$

or (9, p. 20)

$$\sin (\theta - 2\omega) = 0.$$

Hence

$$\theta - 2\omega = 0 \text{ or } \pi.$$

$$\therefore \omega = \frac{1}{2} \theta \text{ or } \omega = \frac{1}{2} \theta - \frac{1}{2} \pi.$$

CASE I. $\omega = \frac{1}{2} \theta - \frac{1}{2} \pi$. Substituting this value of ω in the last two ratios of (1) and simplifying by 4, p. 19, and 6, p. 20, we get

$$\frac{-\cos \frac{1}{2} \theta}{\cos \frac{1}{2} \theta} = \frac{p}{p - h \sin \frac{1}{2} \theta + k \cos \frac{1}{2} \theta}.$$

Solving for p ,

$$p = \frac{1}{2} (h \sin \frac{1}{2} \theta - k \cos \frac{1}{2} \theta).$$

Hence there is always one pair of values of ω and p for which (1) is true, that is, there is always one line which is transformed into itself by (VII).

CASE II. $\omega = \frac{1}{2} \theta$. Substituting this value of ω in the last two ratios in (1), we get

$$\frac{\sin \frac{1}{2} \theta}{\sin \frac{1}{2} \theta} = \frac{p}{p + h \cos \frac{1}{2} \theta + k \sin \frac{1}{2} \theta}.$$

The first of these ratios equals 1, but the second is never equal to 1 unless

$$(2) \quad h \cos \frac{1}{2} \theta + k \sin \frac{1}{2} \theta = 0,$$

in which case p may have any value. Hence there is, in general, but one invariant line. But if (2) is satisfied, all of the lines of a system of parallel lines are invariant.

Since the values of ω in Case I and Case II differ by $\frac{\pi}{2}$, the invariant system of parallel lines is perpendicular to the single invariant line. Q. E. D.

Theorem X. *If the invariant line of a symmetry transformation is the X -axis, then the equations of the transformation are*

$$(X) \quad \begin{cases} x' = x + h, \\ y' = -y. \end{cases}$$

Proof. If the X -axis is invariant, then, if $y = 0$, we must have $y' = 0$ for all values of x . Substituting $y = 0$ and $y' = 0$ in the second of equations (VII), we get

$$x \sin \theta + k = 0.$$

This is true for all values of x when and only when $\sin \theta = 0$ and $k = 0$. If $\sin \theta = 0$, then $\cos \theta = \pm 1$.

Substituting $k = 0$, $\sin \theta = 0$, and $\cos \theta = 1$ in (VII), we get (X).

Substituting $k = 0$, $\sin \theta = 0$, and $\cos \theta = -1$ in (VII), we get

$$x' = -x + h, \quad y' = y.$$

This transformation leaves all of the lines parallel to the X -axis invariant, for if $y = a$, then $y' = a$. Hence the X -axis is not the single invariant line, so that this case is to be excluded; that is, equations (VII) reduce to (X) if the X -axis is the invariant line in Case I of Theorem IX. Q. E. D.

Corollary I. *A symmetry transformation is equivalent to a reflection in a line or to a reflection in a line followed by a translation parallel to it.*

For if $h = 0$, equations (X) reduce to equations (VI).

If $h \neq 0$, equations (X) are equivalent to the two transformations

$$\begin{cases} x'' = x, & \text{and} & x' = x'' + h, \\ y'' = -y, & & y' = y'', \end{cases}$$

which are respectively a reflection in the X -axis and a translation parallel to it.

Corollary II. *The middle points of the lines joining corresponding points of two symmetrical figures lie on a straight line.*

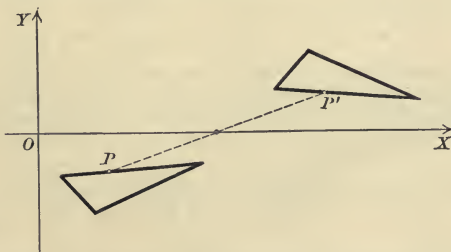

For let (X) be the equations of the symmetry transformation which transforms one figure into the other. The middle point of the line PP' is (Corollary, p. 39)

$$\left[\frac{1}{2}(x + x'), \quad \frac{1}{2}(y + y') \right].$$

Substituting the values of x' and y' from (X), this becomes $(x + \frac{1}{2}h, 0)$, which is a point on the X -axis.

PROBLEMS

1. Find the equations of the curves symmetrical to the following curves with respect to the X -axis and construct the figure.*

(a) $y^2 - 4x = 0.$

(c) $x^2 + 4y^2 - 4x = 0.$

(b) $x^2 + xy - 2y^2 = 0.$

(d) $x^3 - 8y = 0.$

2. Show analytically that the distance between two points is unchanged by (a) a reflection in a line, (b) any symmetry transformation.

3. Show analytically that the numerical value of the angle which one line makes with another is unchanged by (a) a reflection in a line, (b) any symmetry transformation, but that its sign is changed in both cases.

4. Find the equations of the invariant lines which are proved to exist in Theorem IX.

5. Find the equations of a reflection in the Y -axis.

6. Prove that a reflection in a line followed by a reflection in a line perpendicular to the first is equivalent to a rotation through π .

7. A symmetry transformation (VII) has, in general, no fixed points, but if $h(1 + \cos \theta) + k \sin \theta = 0$, then all of the points of the line $x(1 - \cos \theta) - y \sin \theta = k$ are fixed points.

8. If $h(1 + \cos \theta) + k \sin \theta = 0$, then (VII) is a reflection in a line.

9. Find the equations of a reflection in the line $3x + 4y - 10 = 0$.

$$\text{Ans. } x' = \frac{7}{5}x - \frac{24}{5}y + \frac{12}{5}, \quad y' = -\frac{24}{5}x - \frac{7}{5}y + \frac{16}{5}.$$

Hint. The distances from the line to $P(x, y)$ and $P'(x', y')$ (Rule, p. 106) must be equal numerically with opposite signs, and the slope of PP' (Theorem V, p. 35) must be equal to the negative reciprocal of the slope of the given line (Theorem VI, p. 36). These conditions give two equations which may be solved for x' and y' in terms of x and y .

10. Find the equations of a reflection in the line $5x - 12y - 27 = 0$.

$$\text{Ans. } x' = \frac{119}{69}x + \frac{120}{69}y + \frac{270}{69}, \quad y' = \frac{120}{69}x - \frac{119}{69}y - \frac{648}{69}.$$

11. Find the equations of a reflection in the line $Ax + By + C = 0$.

$$\text{Ans. } x' = \frac{B^2 - A^2}{A^2 + B^2}x - \frac{2AB}{A^2 + B^2}y - \frac{2AC}{A^2 + B^2},$$

$$y' = -\frac{2AB}{A^2 + B^2}x - \frac{B^2 - A^2}{A^2 + B^2}y - \frac{2BC}{A^2 + B^2}.$$

119. Congruent and symmetrical conics. The conditions that two conics should be equal are given in Theorem XII, p. 279. We shall now prove

Theorem XI. *Two equal conics are both congruent and symmetrical.*

Proof. Since a conic is symmetrical with respect to its principal axis (p. 174), it is unchanged by a reflection in that axis.

Let C and C' be two congruent conics, and let D be the displacement which transforms C into C' . Then C may be transformed into C' by a reflection in its principal axis followed by the displacement D , that is (Lemma II, p. 287), by a symmetry transformation. Hence C and C' are also symmetrical.

Conversely, let C and C' be two symmetrical conics, and let S be the symmetry transformation which transforms C into C' . Then S is equivalent to a reflection in the principal axis of C followed by a displacement D . Since C is unchanged by a reflection in its principal axis it may be transformed into C' by the displacement D , and hence C and C' are congruent.

Hence two equal conics are both congruent and symmetrical. Q.E.D.

In the figure C may be transformed into C' by a rotation about O or by a symmetry transformation consisting of (Corollary I, p. 289) a reflection in the line S which replaces C by C'' , followed by a translation parallel to S .

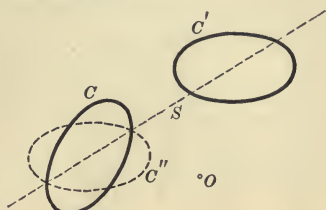

120. Homothetic transformations. Given a fixed point O , the transformation which replaces a point P by a point P' on the line OP such that

$$OP' = \lambda \cdot OP,$$

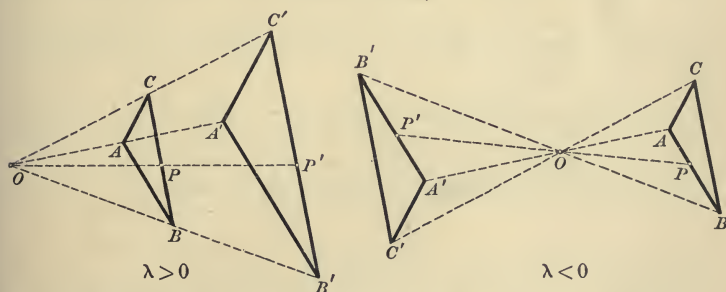

where λ is constant, is called a **homothetic transformation**. O is called the **center** and λ the **ratio** of the transformation. Corresponding figures are called **homothetic figures**. They may easily be proved similar, with the ratio of similitude (that is, the ratio of corresponding lines) equal to λ . Homothetic figures are also similarly placed.

Theorem XII. *The equations of a homothetic transformation whose center is (h, k) and whose ratio is λ are*

$$(XII) \quad \begin{cases} x' = \lambda x + h(1 - \lambda), \\ y' = \lambda y + k(1 - \lambda). \end{cases}$$

Proof. Let P and P' be two corresponding points. Then, by definition,

$$OP' = \lambda \cdot OP.$$

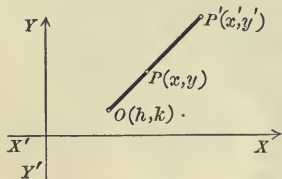

Projecting on the X -axis (Theorem III, p. 31),

$$x' - h = \lambda(x - h).$$

Hence $x' = \lambda x + h(1 - \lambda).$

Similarly, $y' = \lambda y + k(1 - \lambda).$ Q. E. D.

Corollary. *The equations of a homothetic transformation whose center is the origin and whose ratio is λ are*

$$\begin{cases} x' = \lambda x, \\ y' = \lambda y. \end{cases}$$

121. Similitude transformations. A transformation which replaces any figure by one similar to it is called a **similitude transformation**. It is said to be **direct** or **inverse** according as corresponding figures are directly or inversely similar, that is, according as the corresponding parts of the similar figures are in the same or opposite order.

If F and F' are two similar figures whose ratio of similitude is λ , then a homothetic transformation with any center and with the ratio λ will transform F into a figure F'' which is equal to F' . F'' may be transformed into F' either by a displacement or by a symmetry transformation according as F' and F'' are congruent or symmetrical, that is, according as F and F' are directly or inversely similar. Hence

Theorem XIII. *A similitude transformation is equivalent to a homothetic transformation with any center and with its ratio equal to the ratio of similitude of corresponding figures, followed by a displacement or a symmetry transformation according as the similarity is direct or inverse.*

PROBLEMS

Problems 1 to 4 and 5 to 10 are to be solved in order by using those preceding.

1. The equations of a transformation of direct similitude have the form

$$x' = \lambda(x \cos \theta - y \sin \theta + h), \quad y' = \lambda(x \sin \theta + y \cos \theta + k).$$

2. A transformation of direct similitude has one fixed point.

3. If the fixed point is the origin, the equations of a transformation of direct similitude have the form

$$x' = \lambda(x \cos \theta - y \sin \theta), \quad y' = \lambda(x \sin \theta + y \cos \theta).$$

4. A transformation of direct similitude is equivalent to a rotation followed by a homothetic transformation with the same center.

5. The equations of a transformation of inverse similitude have the form

$$x' = \lambda(x \cos \theta + y \sin \theta + h), \quad y' = \lambda(x \sin \theta - y \cos \theta + k).$$

6. The line $x \cos \omega + y \sin \omega - p = 0$ is transformed by a transformation of inverse similitude into the line

$$x \cos(\theta - \omega) + y \sin(\theta - \omega) - \lambda[p + h \cos(\theta - \omega) + k \sin(\theta - \omega)] = 0.$$

7. The perpendicular lines

$$(1 - \lambda)x \cos \frac{1}{2}\theta + (1 - \lambda)y \sin \frac{1}{2}\theta - \lambda(h \cos \frac{1}{2}\theta + k \sin \frac{1}{2}\theta) = 0$$

and $(1 + \lambda)x \sin \frac{1}{2}\theta - (1 + \lambda)y \cos \frac{1}{2}\theta - \lambda(h \sin \frac{1}{2}\theta - k \cos \frac{1}{2}\theta) = 0$

are invariant under a transformation of inverse similitude.

8. A transformation of inverse similitude has a fixed point.

9. If the invariant lines are the axes, the equations of a transformation of inverse similitude have the form $x' = \lambda x, y' = -\lambda y$.

10. A transformation of inverse similitude is equivalent to a reflection in a line followed by a homothetic transformation whose center is on that line.

11. The equations of two congruent, symmetrical, or similar curves are of the same degree.

12. Show that the angle which one line makes with another is unchanged by a homothetic transformation.

13. Show that the distance between two points is multiplied by λ by a homothetic transformation.

14. Show by means of problems 12 and 13 that a homothetic transformation is a similitude transformation.

15. Show that the angle which one line makes with another is unchanged by a transformation of direct similitude, but that its sign is changed by a transformation of inverse similitude.

122. Similar conics. We have seen (Theorem XI, p. 291) that it is unnecessary to distinguish congruent and symmetrical conics, and hence *it is unnecessary to distinguish directly and inversely similar conics.*

Theorem XIV. *If the non-degenerate conic*

$$Ax^2 + Bxy + Cy^2 + Dx + Ey + F = 0$$

is subjected to a homothetic transformation whose center is the origin and whose ratio is λ , then the equation of the homothetic conic is

$$Ax^2 + Bxy + Cy^2 + \lambda Dx + \lambda Ey + \lambda^2 F = 0.$$

This is proved by solving the equations of the transformation (Corollary, p. 292) for x and y , substituting in the given equation, and simplifying.

Theorem XV. *If two conics C and C' are homothetic, the origin being the center and λ the ratio, then*

$$(XV) \quad \frac{H'^2}{\Delta'} = \frac{H^2}{\Delta}, \quad \frac{H'^3}{\Theta'} = \frac{1}{\lambda^2} \frac{H^3}{\Theta},$$

where $\frac{H'^2}{\Delta'}$ and $\frac{H'^3}{\Theta'}$ are the absolute invariants of C' , and $\frac{H^2}{\Delta}$ and $\frac{H^3}{\Theta}$ are those of C .*

Proof. Let the equation of C be

$$Ax^2 + Bxy + Cy^2 + Dx + Ey + F = 0,$$

and then by Theorem XIV that of C' may be written in the form

$$Ax^2 + Bxy + Cy^2 + \lambda Dx + \lambda Ey + \lambda^2 F = 0.$$

The absolute invariants of C' are

$$\frac{H'^2}{\Delta'} = \frac{(A + C)^2}{B^2 - 4AC} = \frac{H^2}{\Delta},$$

$$\frac{H'^3}{\Theta'} = \frac{(A + C)^3}{4AC\lambda^2 F + B\lambda D\lambda E - A(\lambda E)^2 - C(\lambda D)^2 - \lambda^2 FB^2} = \frac{1}{\lambda^2} \frac{H^3}{\Theta}.$$

Q. E. D.

Theorem XVI. *If two non-degenerate conics C and C' are similar, then their absolute invariants and their ratio of similitude λ satisfy equations (XV). Conversely, if the absolute invariants of two conics C and C' satisfy the first of equations (XV) and if the value of λ determined by the second is real, then C and C' are similar, with the ratio λ .*

Proof. By Theorem XIII, p. 292, C may be transformed into C' by a homothetic transformation, whose center is the origin and whose ratio is λ , which transforms C into a conic C'' , followed by a displacement or symmetry transformation which transforms C'' into C' . Then, by Theorem XV,

$$(1) \quad \frac{H''^2}{\Delta''} = \frac{H^2}{\Delta}, \quad \frac{H''^3}{\Theta''} = \frac{1}{\lambda^2} \frac{H^3}{\Theta};$$

and by Theorem XII, p. 279,

$$(2) \quad \frac{H''^2}{\Delta''} = \frac{H'^2}{\Delta'}, \quad \frac{H''^3}{\Theta''} = \frac{H'^3}{\Theta'}.$$

* Theorem V, p. 272. The values of Δ , H , and Θ are given on p. 264.

From equations (1) and (2) we obtain equations (XV).

Conversely, if equations (XV) are satisfied, the value of λ determined by the second being real, then C and C' are similar. For let C be transformed into a conic C'' by a homothetic transformation whose center is the origin and whose ratio is λ .* Then equations (1) are true by Theorem XV. From (1) and (XV) we get equations (2), and hence (Theorem XII, p. 279) C'' and C' are equal. Then C'' may be transformed into C' by either a displacement or a symmetry transformation. Hence C may be transformed into C' by a homothetic transformation followed by a displacement or a symmetry transformation, that is (Theorem XIII, p. 292), by a similitude transformation. Hence C and C' are similar. Q. E. D.

Corollary I. *Two conics are similar if the coefficients of the terms of the second degree are proportional, that is, if*

$$\frac{A}{A'} = \frac{B}{B'} = \frac{C}{C'}$$

and the value of λ determined by the second of equations (XV) is real.

For if r is the common value of these ratios, then

$$A = rA', \quad B = rB', \quad C = rC',$$

and hence

$$\frac{H^2}{\Delta} = \frac{(rA' + rC')^2}{(rB')^2 - 4rA'rC'} = \frac{r^2(A' + C')^2}{r^2(B'^2 - 4A'C')} = \frac{H'^2}{\Delta'}$$

Hence the first of equations (XV) is satisfied.

Corollary II. *Any two parabolas are similar.*

For if C and C' are parabolas, then (Theorem IX, p. 277) $\Delta = 0$ and $\Delta' = 0$. Hence the first of equations (XV) is satisfied. Since $\Delta = 0$, H and Θ have opposite signs (p. 279) and similarly H' and Θ' have opposite signs. Hence the value of λ obtained from the second of equations (XV) is real.

Ex. 1. Show that the conics $x^2 + 2y^2 = 36$ and $3x^2 + 2xy + 3y^2 - 6x - 2y - 5 = 0$ are similar and find the ratio of similitude.

Solution. Computing the absolute invariants of the given equations and substituting in (XV), we obtain

$$\frac{(6)^2}{-32} = \frac{(3)^2}{-8}, \quad \frac{(6)^3}{-256} = \frac{1}{\lambda^2} \frac{(3)^3}{-288}$$

Solving the second equation, we get $\lambda = \pm \frac{1}{3}$. Hence the first of equations (XV) is satisfied, and the second is satisfied if $\lambda = \pm \frac{1}{3}$. The conics are therefore similar, with the ratio of similitude equal to $\pm \frac{1}{3}$. The double sign means that they are either directly or inversely similar.

* The proof would break down at this point if the value of λ determined by the second of equations (XV) were imaginary, because the ratio of a homothetic transformation is a real number.

That such cases arise is illustrated by the hyperbolas $4x^2 - y^2 = 16$ and $-4x^2 + y^2 = 4$, whose absolute invariants satisfy the first of equations (XV); but from the second,

$$\lambda = \pm \frac{1}{2} \sqrt{-1}$$

PROBLEMS

1. Show that the following pairs of conics are similar. Find the ratio of similitude in each case and construct the figure.

(a) $x^2 - 4y^2 = 1$, $3x^2 + 4xy + 4 = 0$. Ans. $\lambda = \pm 2$.

(b) $x^2 + 4y = 0$, $y^2 - 8x = 0$. Ans. $\lambda = \pm 2$.

(c) $9x^2 + y^2 = 9$, $x^2 + 9y^2 - 54y = 0$. Ans. $\lambda = \pm 3$.

(d) $16x^2 + 9y^2 = 144$, $25x^2 + 14xy + 25y^2 = 72$. Ans. $\lambda = \pm \frac{1}{2}$.

(e) $x^2 - y^2 = a^2$, $2xy = a'^2$. Ans. $\lambda = \pm \frac{a'}{a}$.

(f) $y^2 = 2px$, $(x - h)^2 = 2p'(y - k)$. Ans. $\lambda = \pm \frac{p'}{p}$.

2. Show that the ellipses in Ex. 1, p. 200, are similar.

3. Show that the hyperbolas in Ex. 2, p. 201, for which k is positive or for which k is negative, are similar.

4. Show that the locus of $Ax^2 + Bxy + Cy^2 = k$ is, in general, a system of similar conics. Discuss all possible special cases in which this statement is not exact.

5. Any homothetic transformation is equivalent to a homothetic transformation whose center is the origin followed by a translation.

6. By means of problem 4 prove that two conics are homothetic if the coefficients of the terms of the second degree are proportional.

7. Find the center and ratio of the homothetic transformation which transforms $y^2 = 2px$ into $y^2 = 2p'x$. Ans. $(0, 0)$, $\lambda = \frac{p'}{p}$.

8. A homothetic transformation whose center is $O(0, 0)$ and whose ratio is λ followed by a homothetic transformation whose center is $O'(a, 0)$ and whose ratio is λ' is equivalent to a homothetic transformation whose center is $\left(\frac{a - a\lambda}{1 - \lambda\lambda'}, 0\right)$, that is, a point on OO' , and whose ratio is $\lambda\lambda'$.

9. A circle may be transformed into any other circle by two homothetic transformations whose centers, called the centers of similitude of the circles, lie on the line of centers.

Hint. Take the center of one circle for the origin and let the X -axis pass through the center of the other circle. Substitute from (XII), p. 292, in the equation of the first circle and determine h , k , and λ so that the result coincides with the second circle.

10. Given three circles, the line joining a center of similitude of one pair with a center of similitude of a second pair will pass through a center of similitude of the third pair.

Hint. Apply problem 8.

11. The six centers of similitude of three circles taken by pairs lie three by three on four straight lines.

Hint. Apply problem 10.

CHAPTER XIV

INVERSION

123. Definition. Let O be a given point and let P be any point of a figure F . Construct P' on OP such that

$$OP' \cdot OP = 1.$$

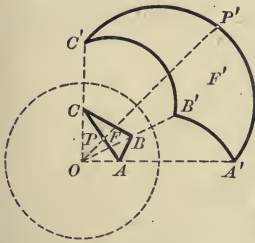

By letting P assume different positions on F , P' will move on a figure F' . The operation or transformation which replaces P by P' is called an inversion, while F and F' are called inverse figures. O is called the center of the inversion.

The figure has been accurately constructed and indicates that the inverse of a triangle is a figure bounded by three curves. Hence we may expect to find that the

properties of inverse figures are, in general, quite different from those of equal or similar figures.

Two important properties of an inversion are immediately evident from the definition.

1. If P approaches the origin, P_1 recedes to infinity, and conversely.

For if OP approaches zero, then OP' must become infinite since $OP' \cdot OP = 1$, and conversely.

2. The points of the circle of unit radius whose center is O are fixed points.

For if $OP = 1$, then from $OP' \cdot OP = 1$ we get $OP' = 1$. Hence P' coincides with P , that is, P is a fixed point. This fact is useful in plotting inverse figures, for the points in which a figure cuts this circle will be points of the inverse figure.

124. Equations of an inversion. By the equations of an inversion we mean two equations involving the coördinates of two corresponding points P and P' . These equations must express the two conditions:

1. That P and P' lie on a line through the center.
2. That $OP' \cdot OP = 1$.

The first of these conditions is satisfied when the triangles OPM and $OP'M'$ are similar, whence

$$(1) \quad \frac{x}{x'} = \frac{y}{y'} = \frac{OP}{OP'}$$

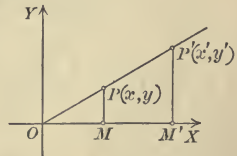

The second condition may be written, by dividing by OP'^2 ,

$$(2) \quad \frac{OP}{OP'} = \frac{1}{OP'^2} = \frac{1}{x'^2 + y'^2} \quad (\text{by (IV), p. 31})$$

From (1) and (2),
$$\frac{x}{x'} = \frac{y}{y'} = \frac{1}{x'^2 + y'^2}.$$

$$\therefore x = \frac{x'}{x'^2 + y'^2}, y = \frac{y'}{x'^2 + y'^2}.$$

Hence we have

Theorem I. *The equations of an inversion whose center is the origin are*

$$(I) \quad x = \frac{x'}{x'^2 + y'^2}, \quad y = \frac{y'}{x'^2 + y'^2}.$$

Ex. 1. Find the inverse of the line $2x + 4y - 1 = 0$.

Solution. Substitute the values of x and y given by (I) in the given equation.

We thus obtain

$$\frac{2x'}{x'^2 + y'^2} + \frac{4y'}{x'^2 + y'^2} - 1 = 0.$$

Reducing and dropping primes, we get

$$x^2 + y^2 - 2x - 4y = 0.$$

This is the equation of a circle whose center is the point $(1, 2)$ and whose radius is $\sqrt{5}$ (Theorem I, p. 131). In the figure a number of inverse points are indicated by the dotted lines.

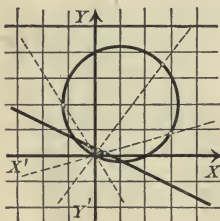

Ex. 2. Find the inverse of the straight line $Ax + By + C = 0$.

Solution. Substitute in the given equation the values of x and y given by (I). This gives

$$\frac{Ax'}{x'^2 + y'^2} + \frac{By'}{x'^2 + y'^2} + C = 0.$$

Simplifying and dropping primes,

$$Cx^2 + Cy^2 + Ax + By = 0.$$

The locus of this equation is a circle (Theorem II, p. 132) which passes through the origin (Theorem VI, p. 73). If $C = 0$, the locus is the given line. Hence

The inverse of a straight line which does not pass through the origin is a circle, and a line which passes through the origin is invariant under an inversion.

Ex. 3. Find the inverse of the circle $x^2 + y^2 + Dx + Ey + F = 0$.

Solution. Substituting from (I), we get

$$\frac{x'^2}{(x'^2 + y'^2)^2} + \frac{y'^2}{(x'^2 + y'^2)^2} + \frac{Dx'}{x'^2 + y'^2} + \frac{Ey'}{x'^2 + y'^2} + F = 0.$$

Multiplying by $x'^2 + y'^2$ and dropping primes,

$$(3) \quad Fx^2 + Fy^2 + Dx + Ey + 1 = 0.$$

The locus is a circle (Theorem II, p. 132) unless $F = 0$, in which case (3) is an equation of the first degree and its locus is a straight line (Theorem II, p. 86). Hence

The inverse of a circle is, in general, a circle, but the inverse of a circle which passes through the origin is a straight line.

PROBLEMS

1. If the origin is the center of inversion, find the inverse of each of the following curves. Construct the figure in each case.

- | | |
|------------------------------------|------------------------------------|
| (a) $2x = 1.$ | (g) $x^2 + y^2 + 4x - 6y - 4 = 0.$ |
| (b) $4y = 1.$ | (h) $3x - 4y = 0.$ |
| (c) $x + y - 1 = 0.$ | (i) $x^2 - y^2 = 0.$ |
| (d) $x^2 + y^2 - 4x = 0.$ | (j) $4x - 3y = 1.$ |
| (e) $x^2 + y^2 = 4.$ | (k) $x^2 + y^2 + 2y = 0.$ |
| (f) $x^2 + y^2 - 2x - 4y + 1 = 0.$ | (l) $y^2 = 4x.$ |

2. Find the inverse of the points $(0, 2)$, $(3, 0)$, $(3, 4)$, $(2, 1)$, $(\frac{1}{2}, 0)$, $(\frac{1}{4}, \frac{1}{8})$, $(a, 0)$, and $(0, b)$. Plot the given and inverse points.

3. Prove by (I) that the points on the unit circle are fixed points.

4. Find the equation of all circles which are unchanged by an inversion whose center is the origin. *Ans.* $x^2 + y^2 + Dx + Ey + 1 = 0.$

5. Show that the inverse of the center of a circle is not, in general, the center of the inverse circle.

6. Show that the center of the circle obtained in Ex. 2 lies on the perpendicular drawn from the origin to the given line.

7. Show that the inverse of a circle whose center is the center of inversion is a concentric circle.

125. Inversion of conic sections. In this section we shall discuss several curves which are obtained by inverting a conic section. These curves have been otherwise defined in Chapter XI.

Theorem II. *The inverse of the parabola is the cissoid if the vertex of the parabola is the center of inversion.*

Proof. If the vertex of the parabola is the origin, its equation is

$$y^2 = 2px.$$

Then, from (I), p. 298,

$$\frac{y'^2}{(x'^2 + y'^2)^2} = \frac{2px'}{x'^2 + y'^2}.$$

Reducing and dropping primes,

$$x^3 = y^2 \left(\frac{1}{2p} - x \right).$$

This is the equation of the cissoid of Diocles (problem 10, p. 253). If we replace $\frac{1}{2p}$ by $2a$, we obtain the form of the equation usually given, namely,

(1) $x^3 = y^2(2a - x).$ Q.E.D.

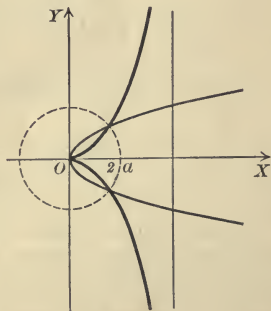

A general discussion (p. 74) gives us the following properties of the cissoid.

1. The cissoid passes through the origin (Theorem VI, p. 73).
2. It is symmetrical with respect to the X -axis (Theorem V, p. 73).
3. Its intercepts on both axes are zero (Rule, p. 73).
4. The cissoid lies entirely between the Y -axis and the line $x = 2a$.

For, solving (1) for y ,

$$(2) \quad y = \pm \sqrt{\frac{x^3}{2a-x}}.$$

If x is negative, the numerator is negative and the denominator positive; and if $x > 2a$, the numerator is positive and the denominator negative. In either case the fraction is negative and y is imaginary.

5. The cissoid recedes indefinitely from the X -axis and approaches the line $x = 2a$.

For as x approaches $2a$ the fraction in (2) becomes larger and approaches infinity as a limit.

This may also be seen by transforming (1) to polar coördinates, which gives

$$\rho = 2a \sin \theta \tan \theta$$

as the polar equation of the cissoid; and hence, if $\theta = \frac{\pi}{2}$ or $\frac{3\pi}{2}$, $\rho = \infty$.

Theorem III. *The inverse of the equilateral hyperbola is the lemniscate if the center of inversion is the center of the hyperbola.*

Proof. The equation of the equilateral hyperbola is (p. 186)

$$x^2 - y^2 = a^2.$$

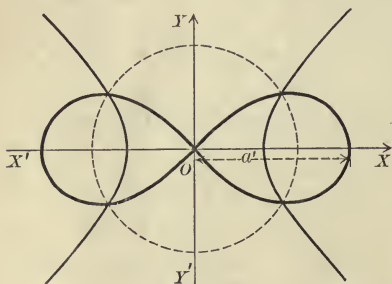

The equation of the inverse curve is (by (I), p. 298)

$$\frac{x^2}{(x^2 + y^2)^2} - \frac{y^2}{(x^2 + y^2)^2} = a^2.$$

Reducing and dropping primes,

$$(x^2 + y^2)^2 = \frac{1}{a^2}(x^2 - y^2).$$

The locus is the lemniscate of Bernoulli (problem 1, (g), p. 248, and problem 4, p. 262). Replacing

$\frac{1}{a^2}$ by a'^2 , we get the form of the equation usually given, namely,

$$(3) \quad (x^2 + y^2)^2 = a'^2(x^2 - y^2). \quad \text{Q. E. D.}$$

A discussion of the equation of the lemniscate in polar coördinates is given in Ex. 2, p. 152. From (3) it is evident that the lemniscate is symmetrical with respect to both axes and the origin (Theorem V, p. 73).

In the figure $a < 1$ and $a' > 1$. If $a = a' = 1$, the lemniscate will be tangent to the hyperbola at its vertices. If $a > 1$ and $a' < 1$, the two curves will not intersect.

Theorem IV. *The inverse of the equilateral hyperbola is the strophoid if the center of inversion is a vertex of the hyperbola.*

The equation of the equilateral hyperbola, when the origin is the right-hand vertex, is

$$x^2 - y^2 + 2ax = 0.$$

This is obtained from $x^2 - y^2 = a^2$ by setting (Theorem I, p. 160) $x = x' + a, y = y'$, and dropping primes.

The inverse curve, from (I), p. 298, is

$$\frac{x'^2}{(x'^2 + y'^2)^2} - \frac{y'^2}{(x'^2 + y'^2)^2} + \frac{2ax'}{x'^2 + y'^2} = 0.$$

Reducing and dropping primes,

$$x(x^2 + y^2) + \frac{1}{2a}(x^2 - y^2) = 0.$$

The locus of this equation is the strophoid (problem 9, p. 262). Replac-

ing $\frac{1}{2a}$ by a' and solving for y^2 , we get the form of the equation usually given, namely,

$$(4) \quad y^2 = x^2 \frac{a' + x}{a' - x}. \quad \text{Q. E. D.}$$

In the figure $a' = 2a = 1$. If $a' > 1$ and $2a < 1$, the left-hand branch of the hyperbola will intersect the loop of the strophoid. If $a' < 1$ and $2a > 1$, the left-hand branch of the hyperbola will not meet the strophoid.

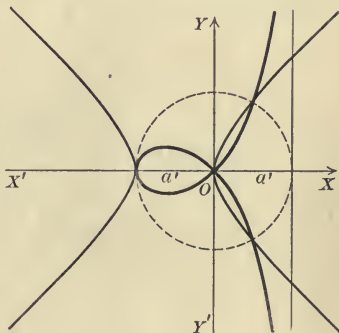

A general discussion of (4) gives us the following properties of the strophoid.

1. It passes through the origin (Theorem VI, p. 73).
2. It is symmetrical with respect to the X -axis.
3. Its intercepts are $y = 0$ or 0 and $x = -a', 0$, or 0 . Hence it passes twice through the origin.
4. The strophoid lies entirely between the lines $x = a'$ and $x = -a'$.

For, solving (4) for y ,

$$(5) \quad y = \pm x \sqrt{\frac{a' + x}{a' - x}} = \pm \frac{x}{a' - x} \sqrt{a'^2 - x^2}.$$

The quadratic under the radical is negative for values of x not lying between the roots (Theorem III, p. 11), and for these values y is imaginary.

5. The strophoid recedes indefinitely from the X -axis and approaches the line $x = a'$.

For, from (5), y becomes infinite when x approaches a' .

Theorem V. *The inverse of a conic is a limaçon if the center of inversion is a focus of the conic.*

Proof. The equation of a conic whose focus is the origin is (Theorem II, p. 178)

$$(1 - e^2)x^2 + y^2 - 2e^2px - e^2p^2 = 0.$$

Substituting from (I), p. 298, the equation of the inverse curve is

$$\frac{(1 - e^2)x'^2}{(x'^2 + y'^2)^2} + \frac{y'^2}{(x'^2 + y'^2)^2} - \frac{2e^2px'}{x'^2 + y'^2} - e^2p^2 = 0.$$

Clearing of fractions, transposing, and dropping primes,

$$e^2p^2(x^2 + y^2)^2 + 2e^2px(x^2 + y^2) = (1 - e^2)x^2 + y^2.$$

Adding e^2x^2 to both sides and dividing by e^2p^2 ,

$$\left(x^2 + y^2 + \frac{1}{p}x\right)^2 = \frac{1}{e^2p^2}(x^2 + y^2).$$

The locus of this equation is the limaçon (problem 11, p. 253). If we set $\frac{1}{p} = a$ and $\frac{1}{e^2p^2} = b^2$, we get the form of the equation usually given, namely,

$$(6) \quad (x^2 + y^2 + ax)^2 = b^2(x^2 + y^2). \quad \text{Q. E. D.}$$

The limaçon has three distinct forms corresponding to the three forms of conics, according as a is less than, equal to, or greater than b . If $a = b$, the limaçon is sometimes called the cardioid (Ex. 2, p. 158).

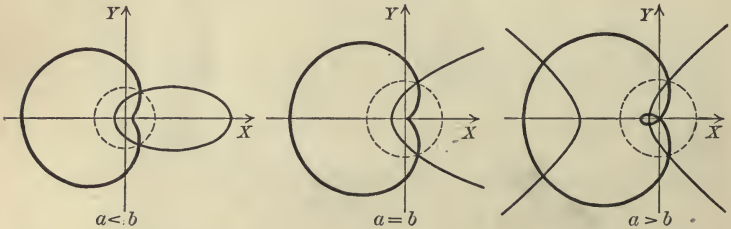

A general discussion of (6) gives us the following properties of the limaçon.

1. It passes through the origin (Theorem VI, p. 73).
2. It is symmetrical with respect to the X -axis (Theorem V, p. 73).
3. Its intercepts are $x = 0, 0, -a - b$, and $-a + b$ and $y = 0, 0, b$, and $-b$. Hence the limaçon passes twice through the origin.
4. The limaçon is a closed curve.

For, transforming to polar coordinates, (6) becomes (Theorem I, p. 155)

$$(\rho^2 + a\rho \cos \theta)^2 = b^2\rho^2.$$

Solving for ρ ,

$$\rho = b - a \cos \theta.$$

Since $-1 \leq \cos \theta \leq 1$, ρ cannot become infinite.

PROBLEMS

1. Construct the following conics, find the equations of the inverse curves, and discuss and construct their loci.

- (a) $y^2 = x, y^2 = 8x, x^2 = 4y.$
- (b) $x^2 - y^2 = 4, x^2 - y^2 = 1, x^2 - y^2 = \frac{1}{4}, 2xy = 1.$
- (c) $x^2 - y^2 + \sqrt{2}x = 0, x^2 - y^2 + x = 0, x^2 - y^2 + 4x = 0.$
- (d) $3x^2 + 4y^2 - 4x = 4, y^2 - 4x = 16, 3x^2 - y^2 + 16x + 16 = 0.$

2. Find the inverse of the hyperbola $3rx^2 - ry^2 + 2x = 0$, and discuss its properties.

Ans. The trisectrix of Maclaurin $x(x^2 + y^2) = \frac{r}{2}(y^2 - 3x^2).$

3. Prove that the inverse of

- (a) the cissoid is a parabola ;
- (b) the lemniscate is an equilateral hyperbola ;
- (c) the strophoid is an equilateral hyperbola ;
- (d) the limaçon is a conic, if the origin is the center of inversion.

4. Prove analytically and geometrically that if a curve C inverts into C' , then C' inverts into C .

5. Show that the inverse of the locus of an equation of the second degree is, in general, a curve whose equation is of the fourth degree. In what combination of x and y will the terms of the fourth degree enter? What will be the degree if the given locus passes through the origin?

126. Angle formed by two circles. If radii be drawn to a point of intersection of two circles, the angle formed is equal to one of the angles formed by the tangents at that point, since their sides are respectively perpendicular. That angle θ is called the angle formed by two circles.

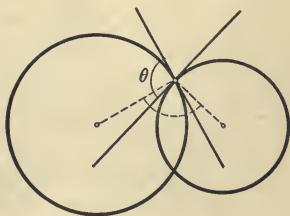

Theorem VI. *The angle θ formed by two intersecting circles*

$$C_1 : x^2 + y^2 + D_1x + E_1y + F_1 = 0$$

and

$$C_2 : x^2 + y^2 + D_2x + E_2y + F_2 = 0$$

is given by

$$(VI) \quad \cos \theta = \frac{D_1D_2 + E_1E_2 - 2F_1 - 2F_2}{\sqrt{D_1^2 + E_1^2 - 4F_1} \sqrt{D_2^2 + E_2^2 - 4F_2}}$$

Proof. By definition θ equals the angle formed by the radii drawn to a point of intersection. Hence from the figure and 17, p. 20,

$$(1) \quad \cos \theta = \frac{r_1^2 + r_2^2 - d^2}{2 r_1 r_2},$$

where r_1 and r_2 are the radii of C_1 and C_2 respectively and d is the length of the line of centers. By Theorem I, p. 131,

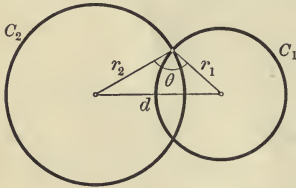

$$r_1 = \frac{1}{2} \sqrt{D_1^2 + E_1^2 - 4 F_1},$$

$$r_2 = \frac{1}{2} \sqrt{D_2^2 + E_2^2 - 4 F_2},$$

and the centers of C_1 and C_2 are respectively $\left(-\frac{D_1}{2}, -\frac{E_1}{2}\right)$ and $\left(-\frac{D_2}{2}, -\frac{E_2}{2}\right)$.

Hence (by (IV), p. 31)

$$d = \sqrt{\left(\frac{D_2}{2} - \frac{D_1}{2}\right)^2 + \left(\frac{E_2}{2} - \frac{E_1}{2}\right)^2} = \frac{1}{2} \sqrt{(D_2 - D_1)^2 + (E_2 - E_1)^2}.$$

Substituting in (1) and reducing, we get (VI).

Q. E. D.

Corollary. C_1 and C_2 are orthogonal if $D_1 D_2 + E_1 E_2 - 2 F_1 - 2 F_2 = 0$.

127. Angles invariant under inversion.

Theorem VII. *The angle between two circles is equal to the angle formed by the inverse circles.*

Proof. Let the equations of two circles be

$$C_1 : x^2 + y^2 + D_1 x + E_1 y + F_1 = 0$$

and

$$C_2 : x^2 + y^2 + D_2 x + E_2 y + F_2 = 0.$$

Then the equations of the inverse circles are respectively [(3), p. 298]

$$C_1' : x^2 + y^2 + \frac{D_1}{F_1} x + \frac{E_1}{F_1} y + \frac{1}{F_1} = 0$$

and

$$C_2' : x^2 + y^2 + \frac{D_2}{F_2} x + \frac{E_2}{F_2} y + \frac{1}{F_2} = 0.$$

By Theorem VI the angle formed by C_1' and C_2' is given by

$$\begin{aligned} \cos \theta' &= \frac{\frac{D_1 D_2}{F_1 F_2} + \frac{E_1 E_2}{F_1 F_2} - \frac{2}{F_1} - \frac{2}{F_2}}{\sqrt{\left(\frac{D_1}{F_1}\right)^2 + \left(\frac{E_1}{F_1}\right)^2 - \frac{4}{F_1}} \sqrt{\left(\frac{D_2}{F_2}\right)^2 + \left(\frac{E_2}{F_2}\right)^2 - \frac{4}{F_2}}} \\ &= \frac{D_1 D_2 + E_1 E_2 - 2 F_1 - 2 F_2}{\sqrt{D_1^2 + E_1^2 - 4 F_1} \sqrt{D_2^2 + E_2^2 - 4 F_2}} \\ &= \cos \theta, \end{aligned}$$

where θ is the angle formed by C_1 and C_2 .

Since θ' and θ are both less than π , we therefore have $\theta' = \theta$.

Q. E. D.

Corollary. *The angles formed by two intersecting curves are equal to the angles formed by the inverse curves.*

For draw two circles respectively tangent to the given curves at a point of intersection. The inverse circles will be tangent to the inverse curves at a point of intersection. The angles formed by either pair of curves and the tangent circles are identical, and the angles formed by the two pairs of circles are equal. Hence the angles formed by the given curves and by the inverse curves are equal.

PROBLEMS

1. Find the angles formed by the following pairs of curves and the angles formed by the inverse curves, and show that they are equal.

(a) $x - y = 0$, $x + 2y = 0$.

(b) $x + 3y - 2 = 0$, $x - 2y = 0$.

(c) $x^2 + y^2 + 4x - 8y = 0$, $x^2 + y^2 - 4x = 0$.

(d) $x^2 + y^2 - 4x + 12 = 0$, $x^2 + y^2 - 8y = 0$.

(e) $x^2 + y^2 - 6x + 4y = 0$, $6x - 4y - 1 = 0$.

2. Show that the circles found in problem 4, p. 299, are orthogonal to the circle $x^2 + y^2 = 1$.

3. If P and P' are two inverse points, show that all of the circles which pass through P and are orthogonal to $x^2 + y^2 = 1$ will also pass through P' .

4. How may problem 3 be used to define an inversion?

5. Into what kind of a figure will three lines forming a triangle invert if the center of inversion is not on one of these lines?

6. Into what kind of a figure will three circles which have a point in common invert if that point is the center of inversion?

7. Three circles pass through a point and intersect each other in three other points. Show that the sum of the angles formed by the circles at these three points is two right angles.

Hint. Invert the figure, using the point common to the three circles as the center of inversion.

8. Three circles pass through the same point. Show how to construct four circles tangent to the three given circles.

Hint. Suppose the required circles constructed. Invert the figure, using the common point as the center of inversion and show how to construct the inverse of the required circles. Then invert the figure so constructed, using the same center of inversion.

9. Show that the sign of an angle is changed by an inversion.

128. Inversion of systems of straight lines.

Theorem VIII. *The inverse of a system of parallel lines is a system of tangent circles whose centers lie on a line perpendicular to the lines of the system.*

Proof. Choose one of the lines of the system for the Y -axis. Then the equation of the system is $x = a$, where a is an arbitrary constant. The inverse system is therefore (by (I), p. 298) $\frac{x'}{x'^2 + y'^2} = a$, or, reducing and

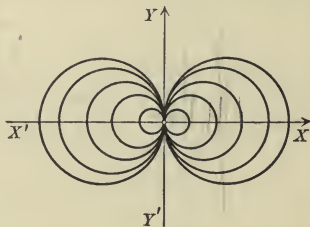
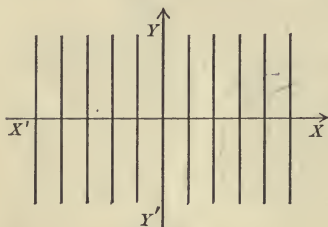

dropping primes, $x^2 + y^2 - \frac{1}{a}x = 0$. This is the equation of a system of circles whose centers lie on the X -axis and which are tangent to each other at the origin (Theorem VIII, p. 144). Q.E.D.

Theorem IX. *The inverse of a system of lines passing through a point is a system of circles passing through the origin and through the inverse of that point.*

Proof. Let the system of lines be $y = mx + b$, where b is constant and m varies. By Theorem I, p. 298, the inverse of the system is, after reducing and dropping primes,

$$x^2 + y^2 + \frac{m}{b}x - \frac{1}{b}y = 0.$$

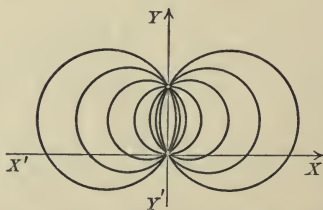
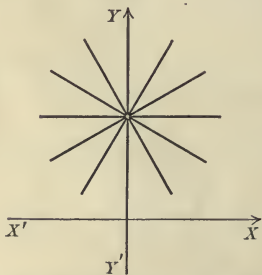

This is the equation of a system of circles passing through the origin (Theorem VI, p. 73) and through $(0, \frac{1}{b})$ (Corollary, p. 53), which is the inverse of $(0, b)$ through which the lines pass. Q.E.D.

129. Inversion of a system of concentric circles.

Theorem X. *The inverse of a system of concentric circles is a system with two limiting points, one at the origin and the other at the inverse of the center of the concentric circles.*

Proof. The equation

$$(1) \quad x^2 + y^2 - 2\beta y + \beta^2 - r^2 = 0$$

represents a system of concentric circles if β is constant and r varies (Theorem II, p. 58).

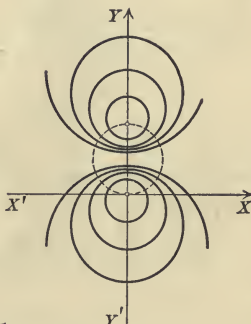
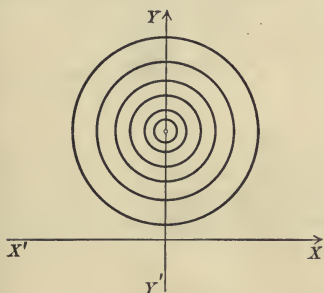

The inverse of (1) is [(3), p. 298]

$$(2) \quad x^2 + y^2 - \frac{2\beta}{\beta^2 - r^2}y + \frac{1}{\beta^2 - r^2} = 0.$$

The locus of (2) is a system of circles with their centers on the Y -axis (Corollary, p. 131). The radius of any one is (Theorem I, p. 131)

$$r' = \frac{1}{2} \sqrt{\left(\frac{-2\beta}{\beta^2 - r^2}\right)^2 - \frac{4}{\beta^2 - r^2}} = \frac{r}{\beta^2 - r^2}.$$

Hence $r' = 0$ if $r = 0$, and the locus of (2) is then the point-circle $\left(0, \frac{1}{\beta}\right)$, which is the inverse of $(0, \beta)$, the center of (1). If $r = \infty$, (2) becomes $x^2 + y^2 = 0$, whose locus is the origin. Hence the system (2) has two limiting points (p. 144), at the origin and at the inverse of the center of (1). Q.E.D.

PROBLEMS

1. Why do we not consider the system of lines passing through the origin in proving Theorem IX?
2. Why do we not take the origin for the center of the system of circles in proving Theorem X?
3. Construct a number of lines of the system $x = a$ and the inverse circles.

4. Construct a number of lines of the system $y = mx + \frac{1}{4}$ and the inverse circles.

5. Construct a number of circles of the system $x^2 + y^2 - 3x + \frac{9}{4} - r^2 = 0$ and the inverse circles.

6. What is the inverse of a system of tangent circles if the point of tangency is the center of inversion?

7. What is the inverse of a system of circles passing through two points one of which is the center of inversion?

8. What is the inverse of a system of circles with two limiting points one of which is the center of inversion?

9. The point $P_1(x_1, y_1)$ may be regarded as a point-circle whose equation is $(x - x_1)^2 + (y - y_1)^2 = 0$. Show that the system of circles represented by $(x - x_1)^2 + (y - y_1)^2 + k(x^2 + y^2 - 1) = 0$ has two limiting points, namely, P_1 and the inverse of P_1 . What is the nature of the system if P_1 lies on the circle $x^2 + y^2 = 1$?

10. How may problem 9 be used to define an inversion?

130. Orthogonal systems of circles. Two systems of circles are said to be orthogonal if each circle of one system is orthogonal (p. 143) to every circle of the other system. The preceding sections enable us to construct such systems with ease.

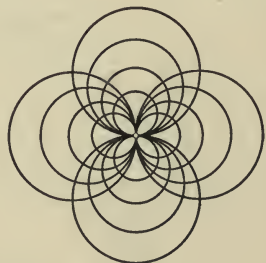
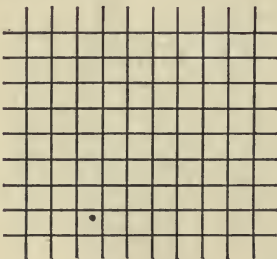

Consider two systems of parallel lines such that the lines of one system are perpendicular to the lines of the other. If we invert these systems of lines, we get two systems of tangent circles whose centers lie respectively on two perpendicular lines (Theorem VIII, p. 306). Since angles are preserved by inversion (Corollary, p. 305) these systems are orthogonal. Hence

Theorem XI. *Two systems of tangent circles are orthogonal if they have the same point of tangency and if their centers lie on perpendicular lines.*

It is also evident that all of the lines passing through the same point P and all of the circles having the center P intersect orthogonally. The inverse of the system of lines is the system of circles passing through

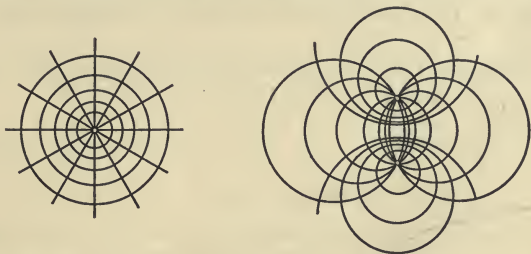

the origin and the inverse of P (Theorem IX, p. 306), and the inverse of the system of concentric circles is the system of circles having the origin and the inverse of P as limiting points (Theorem X, p. 307). Hence

Theorem XII. *Two systems of circles are orthogonal if all the circles of one system pass through two points which are the limiting points of the other.*

MISCELLANEOUS PROBLEMS

1. Show that the degree of an equation is, in general, doubled by an inversion. Will this be true if the terms of the highest degree contain $x^2 + y^2$ as a factor?

2. Construct a linkage consisting of a deformable rhombus $APBP'$ and two bars of equal length OA and OB which are free to rotate about the fixed point O . Show that P and P' describe inverse curves if O is the center of inversion and $\overline{OA}^2 - \overline{AP}^2$ is the unit of length.

3. If P is that point of the rhombus in problem 2 which lies nearest to O , then by adding a bar $O'P$, which is free to rotate about the fixed point O' , P will be constrained to move in a circle. How will P' move? This linkage is known as Peaucellier's Inversor.

4. Show how to construct four circles passing through a given point and tangent to each of two given circles which do not intersect.

Hint. Invert the figure, using the given point as the center of inversion.

5. Find the properties of the cissoid, lemniscate, strophoid, cardioid, and limaçon, which may be obtained from problems 3, 4, 5, 6, 9, 10, 12, and 13, p. 220, by inversion with a proper center.

6. Show that the angle which one line makes with a second equals the angle between the inverse circles, without using the Corollary on p. 305.

CHAPTER XV

POLES AND POLARS. POLAR RECIPROCATATION

131. Pole and polar with respect to a circle. Let $P_1(x_1, y_1)$ be any point and let the equation of a given circle C be

$$(1) \quad x^2 + y^2 = r^2.$$

The line L_1 , whose equation is

$$(2) \quad x_1x + y_1y = r^2,$$

is called the polar of $P_1(x_1, y_1)$ with respect to C , and P_1 is called the pole of L_1 .

Theorem I. *The polar of a point on a circle is the tangent to the circle at that point.*

The proof follows at once from the definition and from the fact that (2) has the same form as the equation of the tangent (Theorem I, p. 212).

Theorem II. *The polar of a point P_1 with respect to a circle is perpendicular to the line passing through P_1 and the center of the circle.*

Proof. The equation of the line passing through P_1 and the origin, the center of the circle (1), is (Theorem VII, p. 97)

$$y_1x - x_1y = 0.$$

This line is perpendicular to (2), the polar of P_1 (Corollary III, p. 87).

Q. E. D.

Corollary. *The angle formed by the polars of two points with respect to a circle is equal to the angle formed by the lines joining those points to the center of the circle.*

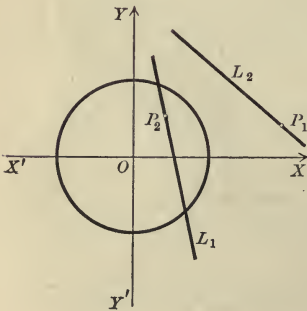

Theorem III. *The polar of any point of a given line passes through the pole of that line.*

Proof. Let L_1 be the given line and let $P_1(x_1, y_1)$ be its pole. Then the equation of L_1 is

$$(3) \quad x_1x + y_1y = r^2.$$

Let $P_2(x_2, y_2)$ be any point on L_1 ; then (Corollary, p. 53)

$$(4) \quad x_1x_2 + y_1y_2 = r^2.$$

The equation of the polar L_2 of the point P_2 is

$$x_2x + y_2y = r^2.$$

This line passes through P_1 , for if the coördinates of P_1 be substituted for x and y , we obtain equation (4), which is known to be true.

Corollary. *The pole of any line is the point of intersection of the polars of any two of its points.*

Theorem IV. *The pole of any line passing through a given point lies on the polar of that point.*

Proof. Let $P_1(x_1, y_1)$ be the given point. Its polar is the line

$$(5) \quad L_1: x_1x + y_1y = r^2.$$

Let $P_2(x_2, y_2)$ be the pole of a line L_2 which passes through P_1 . The equation of L_2 is then

$$x_2x + y_2y = r^2.$$

Since L_2 passes through P_1 we have (Corollary, p. 53)

$$(6) \quad x_2x_1 + y_2y_1 = r^2.$$

Then P_2 lies on L_1 , for when the coördinates of P_2 are substituted in (5) for x and y , we obtain equation (6), which is known to be true. Q. E. D.

Corollary. *The polar of any point is the line passing through the poles of any two lines which pass through the given point.*

132. Construction of poles and polars.

Construction I. To construct the polar of a point P outside of a circle, draw the tangents to the circle which pass through P . The line joining the points of contact of these tangents is the polar of P .

Proof. Let L_1 and L_2 be the tangents to C , and let P_1 and P_2 be their points of tangency. Then the polars of P_1 and P_2 are the lines L_1 and L_2 (Theorem I). Since L_1 and L_2 pass through P , the polar of P is the line L passing through P_1 and P_2 (Corollary to Theorem IV). Q. E. D.

In like manner the following constructions are proved.

Construction II. To construct the pole of a line L which cuts the circle, draw the tangents at the points at which L intersects the circle. The point of intersection of these tangents is the pole of L (Corollary to Theorem III).

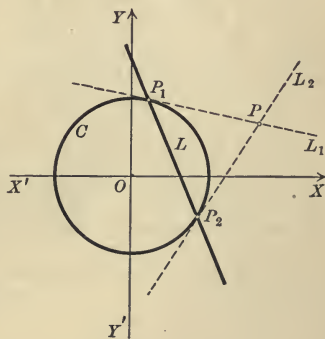

Construction III. To construct the polar of a point P within a circle, construct the poles P_1 and P_2 of two lines L_1 and L_2 passing through P (Construction II). The line joining P_1 and P_2 is the polar of P (Corollary to Theorem IV).

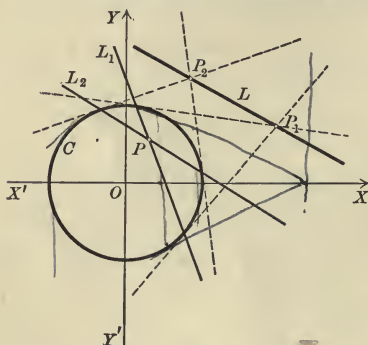

Construction IV. To construct the pole of a line L which does not cut the circle, construct the polars L_1 and L_2 of two points P_1 and P_2 on L (Construction I). The intersection of L_1 and L_2 is the pole of L (Corollary to Theorem III).

PROBLEMS

1. Find the equation of the polar of each of the following points with respect to the given circle and construct the figure.

(a) $(3, -4)$, $x^2 + y^2 = 4$.

(d) $(3, 4)$, $x^2 + y^2 = 36$.

(b) $(-1, 2)$, $x^2 + y^2 = 25$.

(e) $(5, 0)$, $x^2 + y^2 = 49$.

(c) $(7, -2)$, $x^2 + y^2 = 9$.

(f) $(-3, 4)$, $x^2 + y^2 = 25$.

2. Find the pole of each of the following lines with respect to the given circle and construct the figure.

(a) $3x + y = 25$, $x^2 + y^2 = 25$.

Ans. $(3, 1)$.

(b) $3x - 2y = 18$, $x^2 + y^2 = 36$.

Ans. $(6, -4)$.

(c) $x - 4y + 8 = 0$, $x^2 + y^2 = 16$.

Ans. $(-2, 8)$.

(d) $2x - y = 64$, $x^2 + y^2 = 64$.

Ans. $(2, -1)$.

(e) $x - 3y + 16 = 0$, $x^2 + y^2 = 16$.

Ans. $(-1, 3)$.

(f) $x - 3y = 18$, $x^2 + y^2 = 9$.

Ans. $(\frac{1}{2}, -\frac{3}{2})$.

(g) $Ax + By + C = 0$, $x^2 + y^2 = r^2$.

Ans. $(-\frac{Ar^2}{C}, -\frac{Br^2}{C})$.

Hint. Let $P_1(x_1, y_1)$ be the pole of the given line and write down the equation of the polar of P_1 with respect to the given circle. From the conditions that this line shall coincide with the given line (Theorem III, p. 88) determine x_1 and y_1 .

3. Find the distance from the origin to the polar of P_1 with respect to $x^2 + y^2 = r^2$.

Ans. $\frac{r^2}{\sqrt{x_1^2 + y_1^2}}$.

4. By problem 3 show that (a) if P_1 approaches the origin its polar recedes to infinity; (b) if P_1 recedes to infinity its polar approaches the origin.

5. By problem 2, (g), show that if a line recedes to infinity its pole approaches the origin, and if the line approaches the origin its pole recedes to infinity.

6. Find the pole of the line joining $P_1(x_1, y_1)$ and $P_2(x_2, y_2)$ and prove that it is the point of intersection of the polars of P_1 and P_2 .

$$\text{Ans. } \left(\frac{(y_2 - y_1)r^2}{x_1y_2 - x_2y_1}, \frac{(x_1 - x_2)r^2}{x_1y_2 - x_2y_1} \right).$$

7. Find the polar of the point of intersection of $A_1x + B_1y + C_1 = 0$ and $A_2x + B_2y + C_2 = 0$ and prove that it passes through the poles of these lines.

$$\text{Ans. } (B_1C_2 - B_2C_1)x + (C_1A_2 - C_2A_1)y = (A_1B_2 - A_2B_1)r^2.$$

8. If the line $y - y_1 = m(x - x_1)$ revolves about P_1 , the locus of its pole is the polar of P_1 .

9. The radius of a circle is a mean proportional between the distances from its center to any point and to the polar of that point.

133. Polar reciprocation with respect to a circle. The transformation which replaces a given line by its pole with respect to a circle is called a polar reciprocation with respect to that circle. Analytically the transformation is defined by

Theorem V. *The pole of the line*

$$Ax + By + C = 0$$

with respect to the circle

$$x^2 + y^2 = r^2$$

is the point

$$\left(-\frac{Ar^2}{C}; -\frac{Br^2}{C} \right).$$

Proof. Let $P_1(x_1, y_1)$ be the pole of the given line. Then the polar of P_1 is the line

$$x_1x + y_1y - r^2 = 0.$$

Then, by Theorem III, p. 88,

$$\frac{x_1}{A} = \frac{y_1}{B} = \frac{-r^2}{C}.$$

$$\therefore x_1 = -\frac{Ar^2}{C}, \quad y_1 = \frac{-Br^2}{C}. \quad \text{Q.E.D.}$$

The locus C' of the poles of the tangents to a curve C is called the polar reciprocal of C .

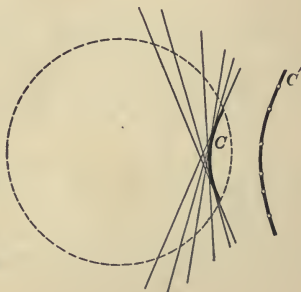

Theorem VI. If C' is the polar reciprocal of a curve C , then C is the polar reciprocal of C' .

Proof. Let l and m be two tangents to C at L and M . Let M' be the pole of m and L' of l . Then L' and M' are two points on C' by definition.

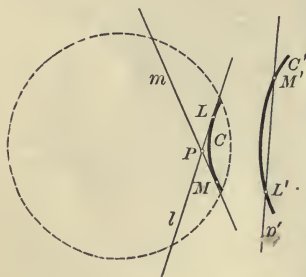

Let p' be the line passing through L' and M' . Then the pole of p' is P , the point of intersection of l and m (Corollary to Theorem III, p. 311).

Let L' move along C' until it comes into coincidence with M' . Then the limiting position of p' is the tangent to C' at M' . But as L' approaches M' , l must approach m , and the limiting position of P is evidently the point M . Hence M is the pole of the tangent to C' at M' . Hence C is the polar reciprocal of C' . Q.E.D.

The method of finding the equation of C' from that of C is illustrated by

Ex. 1. Find the polar reciprocal of the parabola $y^2 = 4x$ with respect to the circle $x^2 + y^2 = 4$.

Solution. Let $P_1(x_1, y_1)$ be any point on the parabola. Then

$$(1) \quad y_1^2 = 4x_1.$$

The equation of the tangent to the parabola at P_1 is (Theorem III, p. 214)

$$(2) \quad y_1y = 2(x + x_1), \text{ or} \\ 2x - y_1y + 2x_1 = 0.$$

By Theorem V, the pole of (2) is the point $P'(x', y')$, where

$$x' = -\frac{4}{x_1}, \quad y' = \frac{2y_1}{x_1}.$$

$$\text{Hence } x_1 = -\frac{4}{x'}, \quad y_1 = -\frac{2y'}{x'}.$$

Substituting in (1),

$$y'^2 = -4x'.$$

This is the equation of the locus of P' , that is, of the polar reciprocal of the given parabola. The polar reciprocal is therefore a parabola of the same size, turned to the left instead of to the right.

The method consists in finding the pole P' of the tangent to the given curve at P_1 , expressing x_1 and y_1 in terms of x' and y' , and substituting in the given equation.

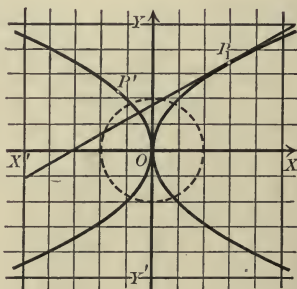

PROBLEMS

1. Find the polar reciprocal of each of the following circles with respect to the circle $x^2 + y^2 = 4$.

(a) $x^2 + y^2 - 4x = 0$.

Ans. $y^2 + 4x = 4$.

(b) $x^2 + y^2 - 2x - 3 = 0$.

Ans. $3x^2 + 4y^2 + 8x - 16 = 0$.

(c) $x^2 + y^2 - 6x + 5 = 0$.

Ans. $5x^2 - 4y^2 - 24x + 16 = 0$.

2. Find the polar reciprocal of each of the following curves with respect to the given circle.

(a) $x^2 + 4y^2 = 16$, $x^2 + y^2 = 1$.

Ans. $16x^2 + 4y^2 = 1$.

(b) $y^2 = 2x - 6$, $x^2 + y^2 = 9$.

Ans. $6x^2 - y^2 - 18x = 0$.

(c) $4x^2 + y^2 = 8x$, $x^2 + y^2 = 4$.

Ans. $y^2 + 2x - 4 = 0$.

3. Verify the answers to problems 1 and 2 by finding the polar reciprocals of the curves given in the answers and applying Theorem VI.

4. Show that the equilateral hyperbola $2xy = 9$ is transformed into itself by a polar reciprocation with respect to the circle $x^2 + y^2 = 9$.

5. Show that the locus of $x^2 - y^2 = a^2$ is transformed into itself by a polar reciprocation with respect to the circle $x^2 + y^2 = a^2$.

134. Pole and polar with respect to the locus of any equation of the second degree. Let $P_1(x_1, y_1)$ be any point and let any equation of the second degree be

(1) $Ax^2 + Bxy + Cy^2 + Dx + Ey + F = 0$.

The line L_1 , whose equation has the same form as the tangent, namely (Theorem II, p. 212),

(2) $Ax_1x + B\frac{y_1x + x_1y}{2} + Cy_1y + D\frac{x + x_1}{2} + E\frac{y + y_1}{2} + F = 0$,

is called the polar of the point P_1 with respect to the locus of (1). P_1 is called the pole of L_1 .

In what follows we speak always of poles and polars with respect to the locus of (1) unless the contrary is stated. The following theorems are generalizations of the theorems indicated, and are proved in the same way by using (1) and (2) of this section instead of (1) and (2) of section 131, p. 310.

Theorem VII. (Generalization of Theorem I.) *The polar of a point on the locus of (1) is the tangent at that point.*

Theorem VIII. (Generalization of Theorems III and IV.) *The polar of any point on a given line passes through the pole of that line. Conversely, the pole of any line passing through a given point lies on the polar of that point.*

Corollary I. *The pole of any line is the point of intersection of the polars of any two of its points.*

Corollary II. *The polar of any point is the line passing through the poles of any two lines which pass through the given point.*

The constructions on pp. 311 and 312 enable us to construct poles and polars with respect to (1), for the theorems by which the constructions are proved have been generalized for the locus of (1).

A good idea of the *direction* of the polar of a point with respect to a conic is afforded by

Theorem IX. *The polar of a point P_1 with respect to a conic is parallel to the tangent to the conic at the point where the diameter through P_1 cuts the conic.*

Proof. The proof is separated into two cases according as the conic is a central conic or a parabola.

CASE I. Central conic. If the center is the origin, its equation may be written

$$Ax^2 + Cy^2 + F = 0.$$

The equation of the polar of P_1 is

$$(3) \quad Ax_1x + Cy_1y + F = 0.$$

Let the diameter through P_1 cut the conic at P_2 . The equation of the tangent at P_2 is

$$(4) \quad Ax_2x + Cy_2y + F = 0.$$

Since P_1 and P_2 are on a line through the origin (Corollary, p. 242),

$$\frac{x_1}{x_2} = \frac{y_1}{y_2},$$

and hence the lines (3) and (4) are parallel (Corollary II, p. 87).

CASE II. Parabola. Its equation is $y^2 = 2px$.

The equation of the polar of P_1 is

$$(5) \quad y_1y = p(x + x_1).$$

Let the diameter through P_1 cut the parabola at P_2 . The equation of the tangent at P_2 is

$$(6) \quad y_2y = p(x + x_2).$$

Since (Theorem X, p. 242) $y_1 = y_2$, the lines (5) and (6) are parallel. Q.E.D.

PROBLEMS

1. Find the equations of the polars of the following points with respect to the given conics and construct the figures.

(a) (3, 4), $9x^2 + 4y^2 = 36$.

(e) (-1, 3), $x^2 + xy - 6y + 4 = 0$.

(b) (2, -1), $16x^2 - y^2 = 64$.

(f) (4, 5), $xy + 4x - 6y - 8 = 0$.

(c) (3, 6), $x^2 + 4y = 0$.

(g) (2, -6), $x^2 + 2xy + y^2 + x - y = 0$.

(d) (2, -4), $xy - 16 = 0$.

(h) (3, 2), $5x^2 + 6xy + 5y^2 - 12 = 0$.

2. Find the poles of the following lines with respect to the given conics and construct the figures.

- (a) $9x + 4y = 36, 9x^2 + y^2 = 36.$ *Ans.* (1, 4).
 (b) $2x - 3y + 4 = 0, y^2 = 4x.$ *Ans.* (2, -3).
 (c) $x - 2y = 16, xy = 8.$ *Ans.* (-2, 1).
 (d) $14x + y = 8, 4x^2 - y^2 = 16.$ *Ans.* (7, -2).
 (e) $2x - y + 13 = 0, x^2 + 4y = 16.$ *Ans.* (-4, -5).
 (f) $x + 4 = 0, x^2 + 4xy + y^2 + 2x + 4 = 0.$ *Ans.* (0, 0).
 (g) $11x + 2y + 18 = 0, 17x^2 - 12xy + 8y^2 - 68x + 24y - 12 = 0.$ *Ans.* (0, -2).

3. Tangents are drawn from the point (8, 4) to the ellipse $x^2 + 4y^2 = 16$. Find the equation of the line joining their points of tangency.

Ans. $x + 2y - 2 = 0.$

4. Tangents are drawn to the hyperbola $16x^2 - y^2 = 64$ at the points of intersection of the hyperbola and the line $8x + 3y + 32 = 0$. Find the coordinates of their point of intersection.

Ans. (-1, 6).

5. How does the polar of a point with respect to a central conic behave if the point approaches the center? if the point recedes to infinity?

6. The polar of the focus of any conic with respect to that conic is the corresponding directrix.

7. The polar of any point on the directrix of a conic passes through the corresponding focus.

8. The polars of a point with respect to conjugate hyperbolas are parallel.

9. The polar of a focus of an ellipse with respect to the major auxiliary circle is the corresponding directrix.

10. What is the locus of a point which lies on its polar with respect to a given conic?

11. That part of the diameter of a parabola included between any point on it and its polar is bisected by the point of contact.

135. Polar reciprocation with respect to the locus of any equation of the second degree. Let

(1) $Ax^2 + Bxy + Cy^2 + Dx + Ey + F = 0$

be any equation of the second degree. Let C be any curve and let C' be the locus of the poles of the tangents to C with respect to the locus of (1). C' is called the polar reciprocal of C with respect to (1).

Theorem X. (Generalization of Theorem VI.) *If C' is the polar reciprocal of C with respect to (1), then C is the polar reciprocal of C' .*

The proof is identical with that of Theorem VI, p. 314. For the theorems on poles and polars with respect to a circle, used in proving that theorem, have been extended to the locus of (1).

Corollary. *The polar reciprocal of C is a curve C' whose tangents are the polars of the points of C .*

The polar reciprocal of a curve C with respect to (1) may therefore be regarded in either one of two ways:

1. As the locus of the poles of the tangents to C .
2. As the curve whose tangents are the polars of the points of C .

In either case the fact to be observed is that to a *point* of one figure corresponds a straight *line* of the other figure and *vice versa*. The transformation which replaces C by C' is called a **polar reciprocation** with respect to (1).

Analytically *the polar reciprocation with respect to (1) is completely defined by the equation*

$$(2) \quad Ax_1x + B\frac{(y_1x + x_1y)}{2} + Cy_1y + D\frac{(x + x_1)}{2} + E\frac{(y + y_1)}{2} + F = 0.$$

For, in the first place, the locus of (2) gives us at once the polar of $P_1(x_1, y_1)$.

In the second place, the pole of any line

$$(3) \quad A'x + B'y + C' = 0$$

is found from (2) as follows. Let $P_1(x_1, y_1)$ be the pole of (3). Then since (2) and (3) are the equations of the polar of the same point P_1 , their loci coincide. Hence (Theorem III, p. 88)

$$\frac{Ax_1 + \frac{B}{2}y_1 + \frac{D}{2}}{A'} = \frac{\frac{B}{2}x_1 + Cy_1 + \frac{E}{2}}{B'} = \frac{\frac{D}{2}x_1 + \frac{E}{2}y_1 + F}{C'}$$

These equations can, in general, be solved for x_1 and y_1 (Theorem IV, p. 90).

The method of finding the equation of the polar reciprocal of a given curve C is illustrated in the following example.

Ex. 1. Find the equation of the polar reciprocal of the ellipse

$$C: 4x^2 + 9y^2 - 1 = 0$$

with respect to the ellipse

$$(4) \quad x^2 + 4y^2 + 2x = 0.$$

Solution. Let $P_1(x_1, y_1)$ be any point on C . Then

$$(5) \quad 4x_1^2 + 9y_1^2 - 1 = 0.$$

The equation of the tangent to C at P_1 is (Theorem III, p. 214)

$$(6) \quad 4x_1x + 9y_1y - 1 = 0.$$

Let $P'(x', y')$ be the pole of (6) with respect to (4). The equation of the polar of P' is

$$(7) \quad (x' + 1)x + 4y'y + x' = 0.$$

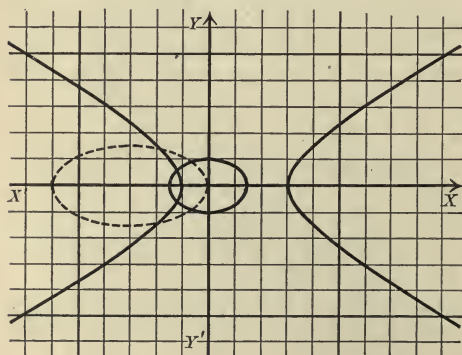

Since (6) and (7) have the same locus (Theorem III, p. 88),

$$\frac{4x_1}{x'+1} = \frac{9y_1}{4y'} = \frac{-1}{x'}$$

Solving for x_1 and y_1 , we obtain

$$x_1 = -\frac{x'+1}{4x'}, \quad y_1 = -\frac{4y'}{9x'}$$

Substituting in (5), we have the required equation

$$4\left(-\frac{x'+1}{4x'}\right)^2 + 9\left(-\frac{4y'}{9x'}\right)^2 - 1 = 0.$$

Reducing and dropping primes, we obtain

$$27x^2 - 64y^2 - 18x - 9 = 0,$$

whose locus is an hyperbola.

In the figure three divisions are taken for unity.

PROBLEMS

1. Find the polar reciprocal of the first of the following curves with respect to the second. Construct the figure in each case.

- | | |
|---------------------------------------------|----------------------------------------------|
| (a) $y^2 - 4x = 0$, $x^2 + 4y = 0$. | <i>Ans.</i> $xy - 2 = 0$. |
| (b) $x^2 + y^2 = 1$, $x^2 - y^2 = 4$. | <i>Ans.</i> $x^2 + y^2 = 16$. |
| (c) $x^2 + 4y^2 = 4$, $4x^2 + y^2 = 4$. | <i>Ans.</i> $64x^2 + y^2 = 16$. |
| (d) $x^2 - 4y^2 = 16$, $x^2 + 4y^2 = 2x$. | <i>Ans.</i> $15x^2 - 64y^2 - 32x + 16 = 0$. |
| (e) $xy - 4 = 0$, $x^2 - y^2 = 16$. | <i>Ans.</i> $xy + 16 = 0$. |
| (f) $8y - x^3 = 0$, $x^2 - y^2 = 4$. | <i>Ans.</i> $2x^3 = 27y$. |

2. Verify the answers to problem 1 by showing that the polar reciprocals of the curves in the answers are the given curves.

3. Show that either of the following curves is unchanged by a polar reciprocation with respect to the other.

- | |
|----------------------------------------------------------------|
| (a) $b^2x^2 + a^2y^2 = a^2b^2$, $b^2x^2 - a^2y^2 = a^2b^2$. |
| (b) $b^2x^2 - a^2y^2 = a^2b^2$, $b^2x^2 - a^2y^2 = -a^2b^2$. |
| (c) $y^2 - 2px = 0$, $y^2 + 2px = 0$. |

4. If the vertices of one triangle are the poles of the sides of a second triangle, then the vertices of the second are the poles of the sides of the first.

Two triangles such that the vertices of either are the poles of the sides of the other are called *conjugate triangles*. If the vertices of a triangle are the poles of the opposite sides, the triangle is said to be *self-conjugate*.

5. Show that (2, 1), (4, 4), and (3, 2) are the vertices of a self-conjugate triangle with respect to the hyperbola $x^2 - y^2 = 4$.

6. Show how to construct a self-conjugate triangle with respect to a given conic if one vertex is given. How many may be constructed?

7. Show that if we reciprocate the figure which is given or implied in one of the following statements, we obtain the corresponding statement.

(a) Two points determine the line on which they lie.

(b) Three points on the same line.

(c) Three points at the vertices of a triangle.

(d) n points at the vertices of a polygon.

(e) An infinite number of points lying on a curve.

(f) A line intersecting a curve in n points.

(g) A curve passing twice through the same point.

(h) A conic section.

(i) A conic may be constructed which passes through five given points.

(j) Two conics intersect in general in four points.

Two lines determine the point in which they intersect.

Three lines through the same point.

Three lines forming a triangle.

n lines forming the sides of a polygon.

An infinite number of lines tangent to a curve.

A point through which pass n lines tangent to a curve.

A curve tangent twice to the same line.

A conic section.

A conic may be constructed which is tangent to five given lines.

Two conics have in general four common tangents.

136. Polar reciprocation of a circle with respect to a circle. The equations of any two circles C and C_1 may be put in the forms

$$C: x^2 + y^2 = r^2$$

and

$$C_1: x^2 + y^2 + Dx + F = 0$$

by taking the center of C as origin and the line of centers of C and C_1 as the X -axis. We shall now find the polar reciprocal of C with respect to C_1 .

Let $P_1(x_1, y_1)$ be any point on C . Then (Corollary, p. 53)

$$(1) \quad x_1^2 + y_1^2 = r^2,$$

and the equation of the tangent to C at P_1 is (Theorem I, p. 212)

$$(2) \quad x_1x + y_1y - r^2 = 0.$$

Let $P'(x', y')$ be the pole of (2) with respect to C_1 ; then the polar of P' is

$$x'x + y'y + D \frac{x + x'}{2} + F = 0,$$

or

$$(3) \quad \left(x' + \frac{D}{2}\right)x + y'y + \frac{D}{2}x' + F = 0.$$

Since (2) and (3) have the same locus (Theorem III, p. 88),

$$\frac{x_1}{x' + \frac{D}{2}} = \frac{y_1}{y'} = \frac{-r^2}{\frac{D}{2}x' + F}.$$

Solving for x_1 and y_1 , we obtain

$$x_1 = -\frac{r^2(2x' + D)}{Dx' + 2F}, \quad y_1 = -\frac{2r^2y'}{Dx' + 2F}.$$

Substituting these values in (1), reducing, and dropping primes, we have the equation of C' , namely,

$$C' : (4r^2 - D^2)x^2 + 4r^2y^2 + 4D(r^2 - F)x + (r^2D^2 - 4F^2) = 0.$$

The discriminant of C' is (p. 265)

$$\Theta' = 16r^2(4r^2 - D^2)(r^2D^2 - 4F^2) - 64r^2D^2(r^2 - F)^2 = -16r^4(D^2 - 4F)^2.$$

As $\frac{1}{2}\sqrt{D^2 - 4F}$ is the radius of C_1 (Theorem I, p. 131), it follows that Θ' is not zero if the radii of C and C_1 are not zero. Hence (Theorem I, p. 266)

Theorem XI. *The polar reciprocal of the circle $C : x^2 + y^2 = r^2$ with respect to the circle $C_1 : x^2 + y^2 + Dx + F = 0$ is the non-degenerate conic C' whose equation is*

$$(XI) \quad (4r^2 - D^2)x^2 + 4r^2y^2 + 4D(r^2 - F)x + (r^2D^2 - 4F^2) = 0.$$

The nature of the conic C' depends upon the sign of

$$\Delta' = -4 \cdot 4r^2(4r^2 - D^2).$$

It is evident that

$$\Delta' < 0 \text{ if } 4r^2 - D^2 > 0, \text{ or } r^2 > \frac{D^2}{4};$$

$$\Delta' > 0 \text{ if } 4r^2 - D^2 < 0, \text{ or } r^2 < \frac{D^2}{4};$$

$$\Delta' = 0 \text{ if } 4r^2 - D^2 = 0, \text{ or } r^2 = \frac{D^2}{4}.$$

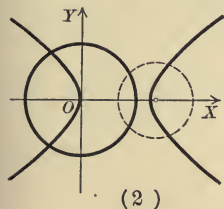
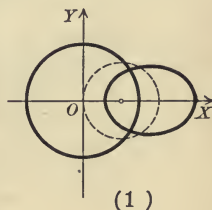

Hence (Theorem IX, p. 277)

$$\text{the conic } C' \text{ is an ellipse if } r^2 > \frac{D^2}{4};$$

$$\text{the conic } C' \text{ is an hyperbola if } r^2 < \frac{D^2}{4};$$

$$\text{the conic } C' \text{ is a parabola if } r^2 = \frac{D^2}{4}.$$

But $\frac{D^2}{4}$ is the square of the distance from the origin to $(-\frac{D}{2}, 0)$, the center of C_1 (Theorem I, p. 131), and therefore

$$\text{the center of } C_1 \text{ is inside of } C \text{ if } r^2 > \frac{D^2}{4};$$

$$\text{the center of } C_1 \text{ is outside of } C \text{ if } r^2 < \frac{D^2}{4};$$

and the center of C_1 is on C if $r^2 = \frac{D^2}{4}$.

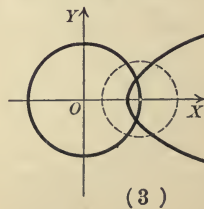

Hence

Theorem XII. *The polar reciprocal of a circle C with respect to a circle C_1 is an ellipse, hyperbola, or parabola according as the center of C_1 is inside of, outside of, or on the circle C .*

PROBLEMS

1. Find the polar reciprocal of the circle $x^2 + y^2 = 4$ with respect to each of the following circles and construct the figure.

(a) $x^2 + y^2 - 4x - 5 = 0$.

Ans. $4y^2 - 36x - 9 = 0$.

(b) $x^2 + y^2 - 2x - 3 = 0$.

Ans. $3x^2 + 4y^2 - 14x - 5 = 0$.

(c) $x^2 + y^2 - 6x = 0$.

Ans. $5x^2 - 4y^2 + 24x - 36 = 0$.

2. Show that the center of C_1 (Theorem XI) is a focus of (XI) and that the corresponding directrix is the polar of the center of C with respect to C_1 .

Hint. Transform (XI) by moving the origin to the center of C_1 , find the focus and directrix by comparison with (II), p. 178, and transform to the old coördinates.

3. If P_1 and P_2 are two points whose polars with respect to a circle C_1 are L_1 and L_2 , then $\frac{l_1}{d_1} = \frac{l_2}{d_2}$, where l_1 and l_2 are the distances from the center of C_1 to P_1 and P_2 , d_1 is the distance from L_2 to P_1 , and d_2 from L_1 to P_2 .

Hint. The center of C_1 may be taken as the origin. Apply (IV), p. 31, and the Rule, p. 106.

4. Prove Theorem XII and problem 2 by means of problem 3 and the definition of a conic (p. 173).

Hint. Let P_2 of problem 3 be the center of C .

5. The angles which two lines L_1 and L_2 (Fig., p. 311), which are tangent to a circle C , make with the polar L of their point of intersection are evidently equal. If we reciprocate the figure with respect to a circle C_1 , what will be the corresponding theorem in the new figure?

Hint. The polar reciprocal of C is a conic whose focus is the center of C_1 (problem 2). To L_1 and L_2 correspond two points on the conic, and to their points of contact correspond the tangents to the conic at these points. To L corresponds the point of intersection of these tangents. Draw lines from the focus to the points of contact of the tangents and to their point of intersection, and apply the Corollary to Theorem II, p. 310.

Ans. If two tangents be drawn to a conic, the line joining the focus to their point of intersection bisects the angle between the focal radii drawn to the point of contact.

6. Obtain the following theorems in the right-hand column from those in the left-hand by means of a polar reciprocation with respect to a circle.

(a) Any tangent to a circle is perpendicular to the radius drawn to the point of contact.

The lines from a focus to any point on a conic and to the point where the tangent at that point meets the directrix are perpendicular.

(b) The angle formed by two tangents to a circle is bisected by the line drawn from the center to their point of intersection.

The angle formed by the focal radii of a conic drawn to its points of intersection with any line is bisected by the line joining the focus to the intersection of that line and the directrix.

(c) The points of intersection of tangents to a circle which intersect at a constant angle lie on a concentric circle.

Chords of a conic which subtend equal angles at the focus are tangent to a conic with the same focus and directrix.

137. Correlations. Any transformation which makes the *points* of one figure correspond to the *lines* of a second figure is called a **correlation**. Polar reciprocations with respect to conics are the most important correlations.

A correlation is completely determined when we are able to find

1. The equation of the line corresponding to a given point.
2. The coördinates of the point corresponding to a given line.

We shall now see that a correlation is defined by an equation of the form

$$(1) \quad (a_1x_1 + b_1y_1 + c_1)x + (a_2x_1 + b_2y_1 + c_2)y + (a_3x_1 + b_3y_1 + c_3) = 0,$$

which is of the first degree in x and y and in x_1 and y_1 .

The locus of (1) is the line corresponding to a given point $P_1(x_1, y_1)$.

To find the point corresponding to a given line

$$(2) \quad Ax + By + C = 0,$$

we suppose that $P_1(x_1, y_1)$ is the required point. The equation of the line corresponding to P_1 is (1). Hence (1) and (2) have the same locus and therefore

$$(3) \quad \frac{a_1x_1 + b_1y_1 + c_1}{A} = \frac{a_2x_1 + b_2y_1 + c_2}{B} = \frac{a_3x_1 + b_3y_1 + c_3}{C}.$$

These equations may, in general, be solved for x_1 and y_1 .

As far as defining the line corresponding to a given point is concerned, the parentheses in (1) might be any complicated expressions in x_1 and y_1 . But if the expressions in those parentheses were not of the first degree, then the equations (3) would have more than *one* pair of solutions for x_1 and y_1 , and hence there would be more than one point corresponding to a given line.

In general the point P_1 will not lie upon the locus of (1). The condition that P_1 should lie on the locus of (1) is (Corollary, p. 53)

$$(a_1x_1 + b_1y_1 + c_1)x_1 + (a_2x_1 + b_2y_1 + c_2)y_1 + (a_3x_1 + b_3y_1 + c_3) = 0,$$

or $a_1x_1^2 + (b_1 + a_2)x_1y_1 + b_2y_1^2 + (c_1 + a_3)x_1 + (c_2 + b_3)y_1 + a_3 = 0.$

This is also the condition that P_1 shall lie upon the locus of the equation

$$(4) \quad a_1x^2 + (b_1 + a_2)xy + b_2y^2 + (c_1 + a_3)x + (c_2 + b_3)y + a_3 = 0.$$

The manner in which the conic sections enter into the theory of correlations is thus given by

Theorem XIII. *The locus of the points which lie upon the lines corresponding to them in the correlation defined by (1) is the conic or degenerate conic whose equation is (4).*

It should be noticed that the correlation defined by (1) is *not*, in general, a polar reciprocation in the curve (4), for (1) is not the equation of the polar of $P_1(x_1, y_1)$ with respect to (4).

Suppose, however, that $b_1 = a_2$, $c_1 = a_3$, and $c_2 = b_3$. Then (4) becomes

$$(5) \quad a_1x^2 + 2a_2xy + b_2y^2 + 2a_3x + 2b_3y + a_3 = 0,$$

and (1) becomes

$$(a_1x_1 + a_2y_1 + a_3)x + (a_2x_1 + b_2y_1 + b_3)y + (a_3x_1 + b_3y_1 + c_3) = 0,$$

or

$$(6) \quad a_1x_1x + a_2(y_1x + x_1y) + b_2y_1y + a_3(x + x_1) + b_3(y + y_1) + c_3 = 0.$$

The locus of (6) is the polar of $P_1(x_1, y_1)$ with respect to (5). Hence we have

Theorem XIV. *If $b_1 = a_2$, $c_1 = a_3$, and $c_2 = b_3$, then the correlation defined by (1) is a polar reciprocation with respect to the locus of (5).*

CHAPTER XVI

CARTESIAN COÖRDINATES IN SPACE

138. Cartesian coördinates. The foundation of Plane Analytic Geometry lies in the possibility of determining a point in the plane by a pair of real numbers (x, y) (p. 25). The study of Solid Analytic Geometry is based on the determination of a point in space by a set of *three* real numbers $x, y,$ and z . This determination is accomplished as follows :

Let there be given three mutually perpendicular planes intersecting in the lines $XX', YY',$ and ZZ' which will also be mutually perpendicular. These three planes are called the **coördinate planes** and may be distinguished as the XY -plane, the YZ -plane, and the ZX -plane. Their lines of intersection are called the **axes of coördinates**, and the positive directions on them are indicated by the arrowheads.* The point of intersection of the coördinate planes is called the **origin**.

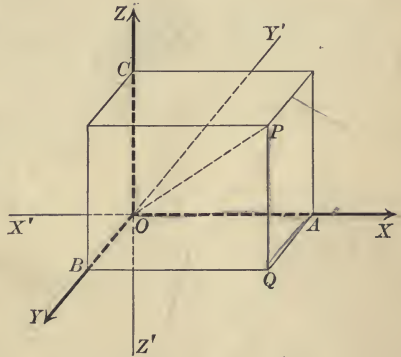

Let P be any point in space and let three planes be drawn through P parallel to the coördinate planes and cutting the axes at $A, B,$ and C . Then the three numbers $OA = x, OB = y,$ and $OC = z$ are called the **rectangular coördinates** of P .

* XX' and ZZ' are supposed to be in the plane of the paper, the positive direction on XX' being to the *right*, that on ZZ' being *upward*. YY' is supposed to be perpendicular to the plane of the paper, the positive direction being *in front* of the paper, that is, from the plane of the paper toward the reader.

Any point P in space determines three numbers, the coördinates of P . Conversely, given any three real numbers x , y , and z , a point P in space may always be constructed whose coördinates are x , y , and z . For if we lay off $OA = x$, $OB = y$, and $OC = z$, and draw planes through A , B , and C parallel to the coördinate planes, they will intersect in such a point P . Hence

Every point determines three real numbers, and conversely, three real numbers determine a point.

The coördinates of P are written (x, y, z) , and the symbol $P(x, y, z)$ is to be read, "The point P whose coördinates are x , y , and z ."

The coördinate planes divide all space into eight parts called **octants**, designated by $O-XYZ$, $O-X'YZ$, etc. The signs of the coördinates of a point in any octant may be determined by the

Rule for signs.

x is positive or negative according as P lies to the right or left of the YZ -plane.

y is positive or negative according as P lies in front or in back of the ZX -plane.

z is positive or negative according as P lies above or below the XY -plane.

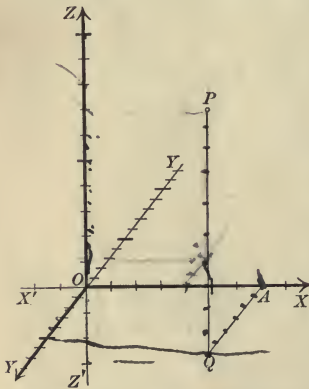

If the coördinate planes are not mutually perpendicular, we still have an analogous system of coördinates called **oblique coördinates**. In this system the coördinates of a point are its distances from the coördinate planes measured parallel to the axes instead of perpendicular to the planes. We shall confine ourselves to the use of rectangular coördinates.

Points in space may be conveniently plotted by marking the same scale on XX' and ZZ' and a somewhat smaller scale on YY' . Then to plot any point, for example $(7, 6, 10)$, we lay off $OA = 7$ on OX , draw AQ parallel to OY and equal to 6 units on OY , and QP parallel to OZ and equal to 10 units on OZ .

PROBLEMS

1. What are the coördinates of the origin?

2. Plot the following sets of points.

(a) $(8, 0, 2)$, $(-3, 4, 7)$, $(0, 0, 5)$.

(b) $(4, -3, 6)$, $(-4, 6, 0)$, $(0, 8, 0)$.

(c) $(10, 3, -4)$, $(-4, 0, 0)$, $(0, 8, 4)$.

(d) $(3, -4, -8)$, $(-5, -6, 4)$, $(8, 6, 0)$.

(e) $(-4, -8, -6)$, $(3, 0, 7)$, $(6, -4, 2)$.

(f) $(-6, 4, -4)$, $(0, -4, 6)$, $(9, 7, -2)$.

3. Where can a point move if $x = 0$? if $y = 0$? if $z = 0$?

4. Where can a point move if $x = 0$ and $y = 0$? if $y = 0$ and $z = 0$? if $z = 0$ and $x = 0$?

5. Show that the points (x, y, z) and $(-x, y, z)$ are symmetrical with respect to the YZ -plane; (x, y, z) and $(x, -y, z)$ with respect to the ZX -plane; (x, y, z) and $(x, y, -z)$ with respect to the XY -plane.

6. Show that the points (x, y, z) and $(-x, -y, z)$ are symmetrical with respect to ZZ' ; (x, y, z) and $(x, -y, -z)$ with respect to XX' ; (x, y, z) and $(-x, y, -z)$ with respect to YY' ; (x, y, z) and $(-x, -y, -z)$ with respect to the origin.

7. What is the value of z if $P(x, y, z)$ is in the XY -plane? of x if P is in the YZ -plane? of y if P is in the ZX -plane?

8. What are the values of y and z if $P(x, y, z)$ is on the X -axis? of z and x if P is on the Y -axis? of x and y if P is on the Z -axis?

9. A rectangular parallelepiped lies in the octant $O-XYZ$ with three faces in the coördinate planes. If its dimensions are a , b , and c , what are the coördinates of its vertices?

139. Orthogonal projections. To extend the first theorem of projection (p. 30) we define the angle between two directed lines in space which do not intersect to be the angle between two intersecting directed lines (p. 28) drawn parallel to the given lines and having their positive directions agreeing with those of the given lines.

The definitions of the orthogonal projection (p. 29) of a point upon a line and of a directed length AB upon a directed line hold when the points and lines lie in space instead of in the plane. It is evident that the projection of a point upon a line

may also be regarded as the point of intersection of the line and the plane passed through the point perpendicular to the line. As two parallel planes are equidistant, then *the projections of a directed length AB upon two parallel lines whose positive directions agree are equal.*

Theorem I. First theorem of projection. *If A and B are points upon a directed line making an angle of γ with a directed line CD , then the*

(I) **projection of the length AB upon $CD = AB \cos \gamma$.**

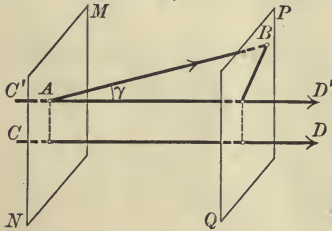

Proof. Draw $C'D'$ through A parallel to CD . Then by definition the angle between AB and $C'D'$ equals γ . Since $C'D'$ and AB intersect we may apply the first theorem of projection in the plane (p. 30), and hence the

projection of the length AB upon $C'D' = AB \cos \gamma$.

Since the projection of AB on CD equals the projection of AB upon $C'D'$ we get (I). Q. E. D.

Theorem II. Second theorem of projection. *If each segment of a broken line in space be given the direction determined in passing continuously from one extremity to the other, then the algebraic sum of the projections of the segments upon any directed line equals the projection of the closing line.*

The proof given on p. 48 holds whether the broken line lies in the plane or in space.

Corollary I. *The projections on the axes of coördinates of the line joining the origin to any point P are respectively the coördinates of P .*

For the projection of OP (Fig., p. 325) upon OX equals the sum of the projections of OA , AQ , and QP , which are respectively equal to x , 0 , and 0 [by (I)]. Similarly for the projections on OY and OZ .

Corollary II. *Given any two points $P_1(x_1, y_1, z_1)$ and $P_2(x_2, y_2, z_2)$, then*

$$x_2 - x_1 = \text{projection of } P_1P_2 \text{ upon } XX',$$

$$y_2 - y_1 = \text{projection of } P_1P_2 \text{ upon } YY',$$

$$z_2 - z_1 = \text{projection of } P_1P_2 \text{ upon } ZZ'.$$

For if we project P_1OP_2 and P_1P_2 upon XX' , we have the
 proj. of P_1O + proj. of OP_2 = proj. of P_1P_2 .

But by Corollary I,

$$\text{proj. of } P_1O = -x_1, \quad \text{proj. of } OP_2 = x_2.$$

$$\therefore x_2 - x_1 = \text{proj. of } P_1P_2 \text{ upon } XX'.$$

In like manner the other formulas are proved.

Corollary III. *If the sides of a polygon be given the direction established by passing continuously around the perimeter, the sum of the projections of the sides upon any directed line is zero.*

PROBLEMS

1. Find the projections upon each of the axes of the sides of the triangles whose vertices are the following points and verify the results by Corollary III.

(a) $(-3, 4, -8), (5, -6, 4), (8, 6, 0)$.

(b) $(-4, -8, -6), (3, 0, 7), (6, 4, -2)$.

(c) $(10, 3, -4), (-4, 0, 2), (0, 8, 4)$.

(d) $(-6, 4, -4), (0, -4, 6), (9, 7, -2)$.

2. If the projections of P_1P_2 on the axes are respectively 3, -2, and 7, and if the coördinates of P_1 are $(-4, 3, 2)$, find the coördinates of P_2 .

Ans. $(-1, 1, 9)$.

3. A broken line joins continuously the points $(6, 0, 0), (0, 4, 3), (-4, 0, 0)$, and $(0, 0, 8)$. Find the sum of the projections of the segments and the projection of the closing line on (a) the X -axis, (b) the Y -axis, (c) the Z -axis, and verify the results by Theorem II. Construct the figure.

4. A broken line joins continuously the points $(6, 8, -3), (0, 0, -3), (0, 0, 6), (-8, 0, 2)$, and $(-8, 4, 0)$. Find the sum of the projections of the segments and the projection of the closing line on (a) the X -axis, (b) the Y -axis, (c) the Z -axis, and verify the results by Theorem II. Construct the figure.

5. Find the projections on the axes of the line joining the origin to each of the points in problem 1.

6. Find the angles between the axes and the line drawn from the origin to

(a) the point (8, 6, 0). *Ans.* $\cos^{-1}\frac{4}{5}$, $\cos^{-1}\frac{3}{5}$, $\frac{\pi}{2}$.

(b) the point (2, -1, -2). *Ans.* $\cos^{-1}\frac{2}{3}$, $\cos^{-1}\left(-\frac{1}{3}\right)$, $\cos^{-1}\left(-\frac{2}{3}\right)$.

7. Find two expressions for the projections upon the axes of the line drawn from the origin to the point $P(x, y, z)$ if the length of the line is ρ and the angles between the line and the axes are α , β , and γ .

8. Find the projections of the coördinates of $P(x, y, z)$ upon the line drawn from the origin to P if the angles between that line and the axes are α , β , and γ . *Ans.* $x \cos \alpha$, $y \cos \beta$, $z \cos \gamma$.

140. Direction cosines of a line. The angles α , β , and γ between a directed line and the axes of coördinates are called the direction angles of the line.

If the line does not intersect the axes, then by definition (p. 327) α , β , and γ are the angles between the axes and a line drawn through the origin parallel to the given line and agreeing with it in direction.

The cosines of the direction angles of a line are called the direction cosines of the line.

Reversing the direction of a line changes the signs of the direction cosines of the line.

For reversing the direction of a line changes α , β , and γ into (p. 28) $\pi - \alpha$, $\pi - \beta$, and $\pi - \gamma$ respectively, and (5, p. 20) $\cos(\pi - x) = -\cos x$.

Theorem III. *If α , β , and γ are the direction angles of a line, then*

(III) $\cos^2 \alpha + \cos^2 \beta + \cos^2 \gamma = 1$.

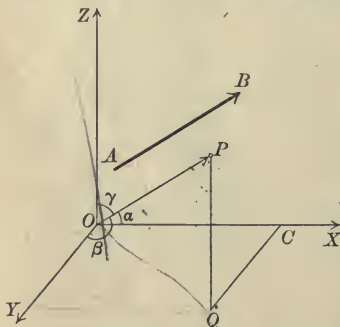

That is, the sum of the squares of the direction cosines of a line is unity.

Proof. Let AB be a line whose direction angles are α , β , and γ . Through O draw OP parallel to AB and let $OP = \rho$. By definition (p. 327) $\angle XOP = \alpha$, $\angle YOP = \beta$, $\angle ZOP = \gamma$. Projecting OP on the axes, we get by Corollary I, p. 328, and Theorem I, p. 328,

(1) $x = \rho \cos \alpha$, $y = \rho \cos \beta$, $z = \rho \cos \gamma$.

Projecting OP and $OCQP$ on OP , we get (Theorems I and II)

$$(2) \quad \rho = x \cos \alpha + y \cos \beta + z \cos \gamma.$$

Substituting from (1) in (2) and dividing by ρ , we obtain (III).

Q. E. D.

Corollary. If $\frac{\cos \alpha}{a} = \frac{\cos \beta}{b} = \frac{\cos \gamma}{c}$, then

$$\begin{aligned} \cos \alpha &= \frac{a}{\pm \sqrt{a^2 + b^2 + c^2}}, & \cos \beta &= \frac{b}{\pm \sqrt{a^2 + b^2 + c^2}}, \\ \cos \gamma &= \frac{c}{\pm \sqrt{a^2 + b^2 + c^2}}. \end{aligned}$$

That is, if the direction cosines of a line are proportional to three numbers, they are respectively equal to these numbers each divided by the square root of the sum of their squares.

For if r denotes the common value of the given ratios, then

$$(3) \quad \cos \alpha = ar, \quad \cos \beta = br, \quad \cos \gamma = cr.$$

Squaring, adding, and applying (III),

$$\begin{aligned} 1 &= r^2(a^2 + b^2 + c^2). \\ \therefore r &= \frac{1}{\pm \sqrt{a^2 + b^2 + c^2}}. \end{aligned}$$

Substituting in (3), we get the values of $\cos \alpha$, $\cos \beta$, and $\cos \gamma$ to be derived.

If a line cuts the XY -plane, it will be directed upward or downward according as $\cos \gamma$ is positive or negative.

If a line is parallel to the XY -plane, $\cos \gamma = 0$ and it will be directed in front or in back of the ZX -plane according as $\cos \beta$ is positive or negative.

If a line is parallel to the X -axis, $\cos \beta = \cos \gamma = 0$, and its positive direction will agree or disagree with that of the X -axis according as $\cos \alpha = 1$ or -1 .

These considerations enable us to choose the sign of the radical in the Corollary so that the positive direction on the line shall be that given in advance.

141. Lengths.

Theorem IV. The length l of the line joining two points $P_1(x_1, y_1, z_1)$ and $P_2(x_2, y_2, z_2)$ is given by

$$(IV) \quad l = \sqrt{(x_1 - x_2)^2 + (y_1 - y_2)^2 + (z_1 - z_2)^2}.$$

Proof. Let the direction angles of the line P_1P_2 be α , β , and γ .

Projecting P_1P_2 on the axes, we get, by Theorem I, p. 328, and Corollary II, p. 329,

$$(1) \quad l \cos \alpha = x_2 - x_1, \quad l \cos \beta = y_2 - y_1, \quad l \cos \gamma = z_2 - z_1.$$

Squaring and adding,

$$\begin{aligned} l^2(\cos^2 \alpha + \cos^2 \beta + \cos^2 \gamma) &= (x_2 - x_1)^2 + (y_2 - y_1)^2 + (z_2 - z_1)^2 \\ &= (x_1 - x_2)^2 + (y_1 - y_2)^2 + (z_1 - z_2)^2. \end{aligned}$$

Applying (III), p. 330, and taking the square root, we get (IV).

Q. E. D.

Corollary. *The direction cosines of the line drawn from P_1 to P_2 are proportional to the projections of P_1P_2 on the axes.*

For, from (1),
$$\frac{\cos \alpha}{x_2 - x_1} = \frac{\cos \beta}{y_2 - y_1} = \frac{\cos \gamma}{z_2 - z_1},$$

since each ratio equals $\frac{1}{l}$, and the denominators are the projections of P_1P_2 on the axes (Corollary II, p. 329).

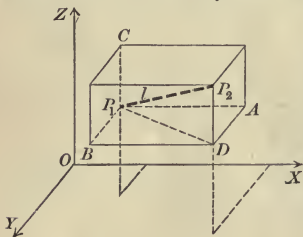

If we construct a rectangular parallelepiped by passing planes through P_1 and P_2 parallel to the coordinate planes, its edges will be parallel to the axes and equal numerically to the projections of P_1P_2 upon the axes. P_1P_2 will be a diagonal of this parallelepiped, and hence l^2 will equal the sum of the squares of its three dimensions. We have thus a second method of deriving (IV).

PROBLEMS

1. Find the length and the direction cosines of the line drawn from

- (a) $P_1(4, 3, -2)$ to $P_2(-2, 1, -5)$. Ans. $7, -\frac{6}{7}, -\frac{2}{7}, -\frac{3}{7}$.
 (b) $P_1(4, 7, -2)$ to $P_2(3, 5, -4)$. Ans. $3, -\frac{1}{3}, -\frac{2}{3}, -\frac{2}{3}$.
 (c) $P_1(3, -8, 6)$ to $P_2(6, -4, 6)$. Ans. $5, \frac{3}{5}, \frac{4}{5}, 0$.

2. Find the direction cosines of a line directed upward if they are proportional to (a) 3, 6, and 2; (b) 2, 1, and -4; (c) 1, -2, and 3.

Ans. (a) $\frac{3}{7}, \frac{6}{7}, \frac{2}{7}$; (b) $\frac{2}{-\sqrt{21}}, \frac{1}{-\sqrt{21}}, \frac{4}{+\sqrt{21}}$; (c) $\frac{1}{\sqrt{14}}, \frac{-2}{\sqrt{14}}, \frac{3}{\sqrt{14}}$.

3. Find the lengths and direction cosines of the sides of the triangles whose vertices are the following points; then find the projections of the sides upon the axes by Theorem I, p. 328, and verify by Corollary III, p. 329.

- (a) $(0, 0, 3), (4, 0, 0), (8, 0, 0)$.
- (b) $(3, 2, 0), (-2, 5, 7), (1, -3, -5)$.
- (c) $(-4, 0, 6), (8, 2, -1), (2, 4, 6)$.
- (d) $(3, -3, -3), (4, 2, 7), (-1, -2, -5)$.

4. In what octant ($O-XYZ, O-X'YZ, \text{etc.}$) will the positive part of a line through O lie if

- (a) $\cos \alpha > 0, \cos \beta > 0, \cos \gamma > 0?$
- (b) $\cos \alpha > 0, \cos \beta > 0, \cos \gamma < 0?$
- (c) $\cos \alpha > 0, \cos \beta < 0, \cos \gamma < 0?$
- (d) $\cos \alpha > 0, \cos \beta < 0, \cos \gamma > 0?$
- (e) $\cos \alpha < 0, \cos \beta > 0, \cos \gamma > 0?$
- (f) $\cos \alpha < 0, \cos \beta < 0, \cos \gamma > 0?$
- (g) $\cos \alpha < 0, \cos \beta < 0, \cos \gamma < 0?$
- (h) $\cos \alpha < 0, \cos \beta > 0, \cos \gamma < 0?$

5. What is the direction of a line if $\cos \alpha = 0? \cos \beta = 0? \cos \gamma = 0?$
 $\cos \alpha = \cos \beta = 0? \cos \beta = \cos \gamma = 0? \cos \gamma = \cos \alpha = 0?$

6. Find the projection of the line drawn from the origin to $P_1(5, -7, 6)$ upon a line whose direction cosines are $\frac{5}{7}, -\frac{3}{7}, \text{and } \frac{2}{7}$. Ans. 9.

Hint. The projection of OP_1 on any line equals the projection of a broken line whose segments equal the coördinates of P_1 .

7. Find the projection of the line drawn from the origin to $P_1(x_1, y_1, z_1)$ upon a line whose direction angles are $\alpha, \beta, \text{and } \gamma$.

Ans. $x_1 \cos \alpha + y_1 \cos \beta + z_1 \cos \gamma$.

8. Show that the points $(-3, 2, -7), (2, 2, -3), \text{and } (-3, 6, -2)$ are the vertices of an isosceles triangle.

9. Show that the points $(4, 3, -4), (-2, 9, -4), \text{and } (-2, 3, 2)$ are the vertices of an equilateral triangle.

10. Show that the points $(-4, 0, 2), (-1, 3\sqrt{3}, 2), (2, 0, 2), \text{and } (-1, \sqrt{3}, 2 + 2\sqrt{6})$ are the vertices of a regular tetrahedron.

11. What does formula (IV) become if P_1 and P_2 lie in the XY -plane? in a plane parallel to the XY -plane?

12. Show that the direction cosines of the lines joining each of the points $(4, -8, 6)$ and $(-2, 4, -3)$ to the point $(12, -24, 18)$ are the same. How are the three points situated?

13. Show by means of direction cosines that the three points $(3, -2, 7), (6, 4, -2), \text{and } (5, 2, 1)$ lie on a straight line.

14. What are the direction cosines of a line parallel to the X -axis? to the Y -axis? to the Z -axis?

15. What is the value of one of the direction cosines of a line parallel to the XY -plane? the YZ -plane? the ZX -plane? What relation exists between the other two?

16. Show that the point $(-1, -2, -1)$ is on the line joining the points $(4, -7, 3)$ and $(-6, 3, -5)$ and is equally distant from them.

17. If two of the direction angles of a line are $\frac{\pi}{3}$ and $\frac{\pi}{4}$, what is the third?
Ans. $\frac{\pi}{3}$ or $\frac{2\pi}{3}$.

18. Find the direction angles of a line which is equally inclined to the three coördinate axes.
Ans. $\alpha = \beta = \gamma = \cos^{-1} \frac{1}{3} \sqrt{3}$.

19. Find the length of a line whose projections on the axes are respectively
 (a) 6, -3, and 2. *Ans.* 7.
 (b) 12, 4, and -3. *Ans.* 13.
 (c) -2, -1, and 2. *Ans.* 3.

142. Angle between two directed lines.

Theorem V. *If α, β, γ and α', β', γ' are the direction angles of two directed lines, then the angle θ between them is given by*

(V) $\cos \theta = \cos \alpha \cos \alpha' + \cos \beta \cos \beta' + \cos \gamma \cos \gamma'$.

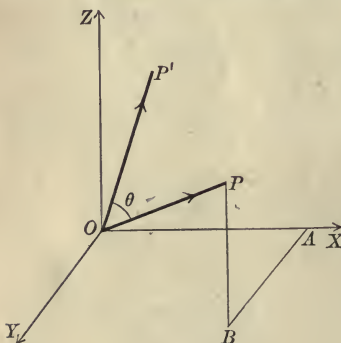

Proof. Draw OP and OP' parallel to the given lines and let $OP = \rho$. Then by definition, p. 327,

$$\angle POP' = \theta.$$

Project OP and $OABP$ on OP' . Then by Theorem I, p. 328, and Theorem II, p. 328,

$$(1) \rho \cos \theta = x \cos \alpha' + y \cos \beta' + z \cos \gamma'.$$

Projecting OP on the axes (Corollary I, p. 328, and Theorem I),

(2) $x = \rho \cos \alpha, \quad y = \rho \cos \beta, \quad z = \rho \cos \gamma.$

Substituting in (1) from (2) and dividing by ρ , we obtain (V).

Theorem VI. *If α, β, γ and α', β', γ' are the direction angles of two lines, then the lines are*

(a) *parallel and in the same direction* when and only when*

$$\alpha = \alpha', \beta = \beta', \gamma = \gamma';$$

(b) *perpendicular† when and only when*

$$\cos \alpha \cos \alpha' + \cos \beta \cos \beta' + \cos \gamma \cos \gamma' = 0.$$

That is, two lines are parallel and in the same direction when and only when their direction angles are equal, and perpendicular when and only when the sum of the products of their direction cosines is zero.

Proof. The condition for parallelism follows from the fact that both lines will be parallel to and agree in direction with the same line through the origin when and only when their direction angles are equal.

The condition for perpendicularity follows from (V), for if $\theta = \frac{\pi}{2}$, then $\cos \theta = 0$, and conversely. Q. E. D.

Corollary. *If the direction cosines of the lines are proportional to a, b, c and a', b', c' , then the conditions for parallelism and perpendicularity are respectively*

$$\frac{a}{a'} = \frac{b}{b'} = \frac{c}{c'}, \quad aa' + bb' + cc' = 0. \quad \color{red}{\downarrow}$$

143. Point of division.

Theorem VII. *The coördinates (x, y, z) of the point of division P on the line joining $P_1(x_1, y_1, z_1)$ and $P_2(x_2, y_2, z_2)$ such that the ratio of the segments is*

$$\frac{P_1P}{PP_2} = \lambda$$

are given by the formulas

$$(VII) \quad x = \frac{x_1 + \lambda x_2}{1 + \lambda}, \quad y = \frac{y_1 + \lambda y_2}{1 + \lambda}, \quad z = \frac{z_1 + \lambda z_2}{1 + \lambda}.$$

This is proved as on p. 39.

* They will be parallel and differ in direction when and only when the direction angles are supplementary.

† Two lines in space are said to be perpendicular when the angle between them is $\frac{\pi}{2}$, but the lines do not necessarily intersect.

Corollary. *The coördinates (x, y, z) of the middle point P of the line joining $P_1(x_1, y_1, z_1)$ and $P_2(x_2, y_2, z_2)$ are*

$$x = \frac{1}{2}(x_1 + x_2), \quad y = \frac{1}{2}(y_1 + y_2), \quad z = \frac{1}{2}(z_1 + z_2). \quad \circ$$

PROBLEMS

1. Find the angle between two lines whose direction cosines are respectively

- (a) $\frac{6}{7}, \frac{3}{7}, -\frac{2}{7}$ and $\frac{3}{7}, -\frac{2}{7}, \frac{6}{7}$. Ans. $\frac{\pi}{2}$.
 (b) $\frac{2}{3}, -\frac{1}{3}, \frac{2}{3}$ and $-\frac{3}{13}, \frac{4}{13}, \frac{12}{13}$. Ans. $\cos^{-1} \frac{14}{13}$.
 (c) $\frac{2}{3}, -\frac{2}{3}, \frac{1}{3}$ and $\frac{3}{7}, \frac{6}{7}, \frac{2}{7}$. Ans. $\cos^{-1}(-\frac{4}{21})$.

2. Show that the lines whose direction cosines are $\frac{3}{7}, \frac{6}{7}, \frac{2}{7}$; $-\frac{2}{7}, \frac{3}{7}, -\frac{6}{7}$; and $-\frac{6}{7}, \frac{2}{7}, \frac{3}{7}$ are mutually perpendicular.

3. Show that the lines joining the following pairs of points are either parallel or perpendicular.

- (a) $(3, 2, 7), (1, 4, 6)$ and $(7, -5, 9), (5, -3, 8)$.
 (b) $(13, 4, 9), (1, 7, 13)$ and $(7, 16, -6), (3, 4, -9)$.
 (c) $(-6, 4, -3), (1, 2, 7)$ and $(8, -5, 10), (15, -7, 20)$.

4. Find the coördinates of the point dividing the line joining the following points in the ratio given.

- (a) $(3, 4, 2), (7, -6, 4)$, $\lambda = \frac{1}{2}$. Ans. $(\frac{13}{3}, \frac{2}{3}, \frac{8}{3})$.
 (b) $(-1, 4, -6), (2, 3, -7)$, $\lambda = -3$. Ans. $(\frac{7}{2}, \frac{5}{2}, -\frac{15}{2})$.
 (c) $(8, 4, 2), (3, 9, 6)$, $\lambda = -\frac{1}{3}$. Ans. $(\frac{23}{3}, \frac{3}{2}, 0)$.
 (d) $(7, 3, 9), (2, 1, 2)$, $\lambda = 4$. Ans. $(3, \frac{7}{5}, \frac{17}{5})$.

5. Show that the points $(7, 3, 4), (1, 0, 6)$, and $(4, 5, -2)$ are the vertices of a right triangle.

6. Show that the points $(-6, 3, 2), (3, -2, 4), (5, 7, 3)$, and $(-13, 17, -1)$ are the vertices of a trapezoid.

7. Show that the points $(3, 7, 2), (4, 3, 1), (1, 6, 3)$, and $(2, 2, 2)$ are the vertices of a parallelogram.

8. Show that the points $(6, 7, 3), (3, 11, 1), (0, 3, 4)$, and $(-3, 7, 2)$ are the vertices of a rectangle.

9. Show that the points $(6, -6, 0), (3, -4, 4), (2, -9, 2)$, and $(-1, -7, 6)$ are the vertices of a rhombus.

10. Show that the points $(7, 2, 4), (4, -4, 2), (9, -1, 10)$, and $(6, -7, 8)$ are the vertices of a square.

11. Show that each of the following sets of points lies on a straight line, and find the ratio of the segments in which the third divides the line joining the first to the second.

(a) (4, 13, 3), (3, 6, 4), and (2, -1, 5). *Ans.* -2.

(b) (4, -5, -12), (-2, 4, 6), and (2, -2, -6). *Ans.* $\frac{1}{2}$.

(c) (-3, 4, 2), (7, -2, 6), and (2, 1, 4). *Ans.* 1.

12. Find the lengths of the medians of the triangle whose vertices are the points (3, 4, -2), (7, 0, 8), and (-5, 4, 6). *Ans.* $\sqrt{113}$, $\sqrt{89}$, $2\sqrt{29}$.

13. Show that the lines joining the middle points of the opposite sides of the quadrilaterals whose vertices are the following points bisect each other.

(a) (8, 4, 2), (0, 2, 5), (-3, 2, 4), and (8, 0, -6).

(b) (0, 0, 9), (2, 6, 8), (-8, 0, 4), and (0, -8, 6).

(c) $P_1(x_1, y_1, z_1)$, $P_2(x_2, y_2, z_2)$, $P_3(x_3, y_3, z_3)$, $P_4(x_4, y_4, z_4)$.

14. Show that the lines joining successively the middle points of the sides of any quadrilateral form a parallelogram.

15. Find the projection of the line drawn from $P_1(3, 2, -6)$ to $P_2(-3, 5, -4)$ upon a line directed upward whose direction cosines are proportional to 2, 1, and -2. *Ans.* $4\frac{1}{3}$.

16. Find the projection of the line drawn from $P_1(6, 3, 2)$ to $P_2(4, 2, 0)$ upon the line drawn from $P_3(7, -6, 0)$ to $P_4(-5, -2, 3)$. *Ans.* $\frac{1}{3}$.

17. Find the coördinates of the point of intersection of the medians of the triangle whose vertices are (3, 6, -2), (7, -4, 3), and (-1, 4, -7). *Ans.* (3, 2, -2).

18. Find the coördinates of the point of intersection of the medians of the triangle whose vertices are any three points P_1 , P_2 , and P_3 .
Ans. $[\frac{1}{3}(x_1 + x_2 + x_3), \frac{1}{3}(y_1 + y_2 + y_3), \frac{1}{3}(z_1 + z_2 + z_3)]$.

19. The three lines joining the middle points of the opposite edges of a tetrahedron pass through the same point and are bisected at that point.

20. The four lines drawn from the vertices of any tetrahedron to the point of intersection of the medians of the opposite face meet in a point which is three fourths of the distance from each vertex to the opposite face (the center of gravity of the tetrahedron).

CHAPTER XVII

SURFACES, CURVES, AND EQUATIONS

144. Loci in space. In Solid Geometry it is necessary to consider two kinds of loci :

1. The locus of a point in space which satisfies *one* given condition is, in general, a *surface*.

Thus the locus of a point at a given distance from a fixed point is a sphere, and the locus of a point equidistant from two fixed points is the plane which is perpendicular to the line joining the given points at its middle point.

2. The locus of a point in space which satisfies *two* conditions* is, in general, a *curve*. For the locus of a point which satisfies either condition is a surface, and hence the points which satisfy both conditions lie on two surfaces, that is, on their curve of intersection.

Thus the locus of a point which is at a given distance r from a fixed point P_1 and is equally distant from two fixed points P_2 and P_3 is the circle in which the sphere whose center is P_1 and whose radius is r intersects the plane which is perpendicular to P_2P_3 at its middle point.

These two kinds of loci must be carefully distinguished.

145. Equation of a surface. First fundamental problem. If any point P which lies on a given surface be given the coördinates (x, y, z) , then the condition which defines the surface as a locus will lead to an equation involving the variables x, y , and z .

The equation of a surface is an equation in the variables x, y , and z representing coördinates such that :

1. The coördinates of every point on the surface will satisfy the equation.

2. Every point whose coördinates satisfy the equation will lie upon the surface.

* The number of conditions must be counted carefully. Thus if a point is to be equidistant from three fixed points P_1, P_2 , and P_3 , it satisfies *two* conditions, namely, of being equidistant from P_1 and P_2 and from P_2 and P_3 .

If the surface is defined as the locus of a point satisfying one condition, its equation may be found in many cases by a Rule analogous to that on p. 53.

Ex. 1. Find the equation of the locus of a point whose distance from $P_1(3, 0, -2)$ is 4.

Solution. Let $P(x, y, z)$ be any point on the locus. The given condition may be written

$$P_1P = 4.$$

$$\text{By (IV), p. 331, } P_1P = \sqrt{(x-3)^2 + y^2 + (z+2)^2}.$$

$$\therefore \sqrt{(x-3)^2 + y^2 + (z+2)^2} = 4.$$

Simplifying, we obtain as the required equation

$$x^2 + y^2 + z^2 - 6x + 4z - 3 = 0.$$

That this is indeed the equation of the locus should be verified as in Ex. 1, p. 52, and Ex. 1, p. 53.

PROBLEMS

1. Find the equation of the locus of a point which is

- (a) 3 units above the XY -plane.
- (b) 4 units to the right of the YZ -plane.
- (c) 5 units below the XY -plane.
- (d) 10 units back of the ZX -plane.
- (e) 7 units to the left of the YZ -plane.
- (f) 2 units in front of the ZX -plane.

2. Find the equation of the plane which is parallel to

- (a) the XY -plane and 4 units above it.
- (b) the XY -plane and 5 units below it.
- (c) the ZX -plane and 3 units in front of it.
- (d) the YZ -plane and 7 units to the left of it.
- (e) the ZX -plane and 2 units back of it.
- (f) the YZ -plane and 4 units to the right of it.

3. Find the equation of the sphere whose center is the point

(a) $(3, 0, 4)$ and whose radius is 5.

$$\text{Ans. } x^2 + y^2 + z^2 - 6x - 8z = 0.$$

(b) $(-3, 2, 1)$ and whose radius is 4.

$$\text{Ans. } x^2 + y^2 + z^2 + 6x - 4y - 2z - 2 = 0.$$

(c) $(6, 4, 0)$ and whose radius is 7.

$$\text{Ans. } x^2 + y^2 + z^2 - 12x - 8y + 3 = 0.$$

(d) (α, β, γ) and whose radius is r .

$$\text{Ans. } x^2 + y^2 + z^2 - 2\alpha x - 2\beta y - 2\gamma z + \alpha^2 + \beta^2 + \gamma^2 - r^2 = 0.$$

4. What are the equations of the coördinate planes?

5. What is the form of the equation of a plane which is parallel to the XY -plane? the YZ -plane? the ZX -plane?

6. Find the equation of the locus of a point which is equally distant from the points

(a) $(3, 2, -1)$ and $(4, -3, 0)$. *Ans.* $2x - 10y + 2z - 11 = 0$.

(b) $(4, -3, 6)$ and $(2, -4, 2)$. *Ans.* $4x + 2y + 8z - 37 = 0$.

(c) $(1, 3, 2)$ and $(4, -1, 1)$. *Ans.* $3x - 4y - z - 2 = 0$.

(d) $(4, -6, -8)$ and $(-2, 7, 9)$. *Ans.* $6x - 13y - 17z + 9 = 0$.

7. Find the equations of the six planes drawn through the middle points of the edges of the tetraedron whose vertices are the points $(5, 4, 0)$, $(2, -5, -4)$, $(1, 7, -5)$, and $(-4, 3, 4)$ which are perpendicular to the edges, and show that they all pass through the point $(-1, 1, -2)$.

8. What are the equations of the faces of the rectangular parallelepiped which has one vertex at the origin, three edges lying along the coördinate axes, and one vertex at the point $(3, 5, 7)$?

9. Find the equation of the sphere whose center is the point $(6, 2, 3)$ which passes through the origin. *Ans.* $x^2 + y^2 + z^2 - 12x - 4y - 6z = 0$.

10. Find the equation of the locus of a point which is three times as far from the point $(2, 6, 8)$ as from $(4, -2, 4)$ and determine the nature of the locus by comparison with the answer to problem 3, (d).

11. Find the equation of the locus of a point the sum of the squares of whose distances from $(1, 3, -2)$ and $(6, -4, 2)$ is 50 and determine the nature of the locus by comparison with the answer to problem 3, (d).

146. Planes parallel to the coördinate planes. We may easily prove

Theorem I. *The equation of a plane which is*

parallel to the XY -plane has the form $z = \text{constant}$;

parallel to the YZ -plane has the form $x = \text{constant}$;

parallel to the ZX -plane has the form $y = \text{constant}$.

147. Equations of a curve. First fundamental problem. If any point P which lies on a given curve be given the coördinates (x, y, z) , then the two conditions which define the curve as a locus will lead to two equations involving the variables x, y , and z .

The equations of a curve are *two* equations in the variables x , y , and z representing coördinates such that:

1. The coördinates of every point on the curve will satisfy both equations.

2. Every point whose coördinates satisfy both equations will lie on the curve.

If the curve is defined as the locus of a point satisfying two conditions, the equations of the surfaces defined by each condition separately may be found in many cases by a Rule analogous to that on p. 53. These equations will be the equations of the curve.

Ex. 1. Find the equations of the locus of a point whose distance from the origin is 4 and which is equally distant from the points $P_1(8, 0, 0)$ and $P_2(0, 8, 0)$.

Solution. First step. Let $P(x, y, z)$ be any point on the locus.

Second step. The given conditions are

$$(1) \quad PO = 4, \quad PP_1 = PP_2.$$

Third step. By (IV), p. 331,

$$PO = \sqrt{x^2 + y^2 + z^2},$$

$$PP_1 = \sqrt{(x - 8)^2 + y^2 + z^2},$$

$$PP_2 = \sqrt{x^2 + (y - 8)^2 + z^2}.$$

Substituting in (1), we get

$$\sqrt{x^2 + y^2 + z^2} = 4, \quad \sqrt{(x - 8)^2 + y^2 + z^2} = \sqrt{x^2 + (y - 8)^2 + z^2}.$$

Squaring and reducing, we have the required equations, namely,

$$x^2 + y^2 + z^2 = 16, \quad x - y = 0.$$

These equations should be verified as in Ex. 1, p. 52.

Ex. 2. Find the equations of the circle lying in the XY -plane whose center is the origin and whose radius is 5.

Solution. In Plane Geometry the equation of the circle is (Corollary, p. 58)

$$(2) \quad x^2 + y^2 = 25.$$

Regarded as a problem in Solid Geometry we must have *two* equations which the coördinates of any point $P(x, y, z)$ which lies on the circle must satisfy. Since P lies in the XY -plane,

$$(3) \quad z = 0.$$

Hence equations (2) and (3) together express that the point P lies in the XY -plane and on the given circle. The equations of the circle are therefore

$$x^2 + y^2 = 25, \quad z = 0.$$

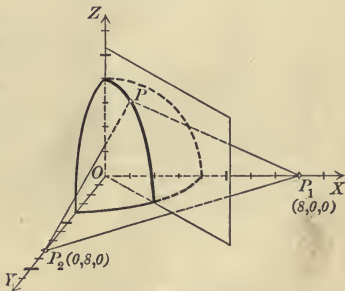

The reasoning in Ex. 2 is general. Hence

If the equation of a curve in the XY -plane is known, then the equations of that curve regarded as a curve in space are the given equation and $z = 0$.

An analogous statement evidently applies to the equations of a curve lying in one of the other coordinate planes.

From Theorem I, p. 340, we have at once

Theorem II. *The equations of a line which is parallel to*

the X -axis have the form $y = \text{constant}$, $z = \text{constant}$;

the Y -axis have the form $z = \text{constant}$, $x = \text{constant}$;

the Z -axis have the form $x = \text{constant}$, $y = \text{constant}$.

PROBLEMS

1. Find the equations of the locus of a point which is

- (a) 3 units above the XY -plane and 4 units to the right of the YZ -plane.
- (b) 5 units to the left of the YZ -plane and 2 units in front of the ZX -plane.
- (c) 4 units back of the ZX -plane and 7 units to the left of the YZ -plane.
- (d) 9 units below the XY -plane and 4 units to the right of the YZ -plane.

2. Find the equations of the straight line which is

- (a) 5 units above the XY -plane and 2 units in front of the ZX -plane.
- (b) 2 units to the left of the YZ -plane and 8 units below the XY -plane.
- (c) 3 units to the right of the YZ -plane and 5 units from the Z -axis.
- (d) 13 units from the X -axis and 5 units back of the ZX -plane.
- (e) parallel to the Y -axis and passing through $(3, 7, -5)$.
- (f) parallel to the Z -axis and passing through $(-4, 7, 6)$.

3. Find the equations of the locus of a point which is

- (a) 5 units above the XY -plane and 3 units from $(3, 7, 1)$.
 $\text{Ans. } z = 5, x^2 + y^2 + z^2 - 6x - 14y - 2z + 50 = 0.$
- (b) 2 units from $(3, 7, 6)$ and 4 units from $(2, 5, 4)$.
 $\text{Ans. } x^2 + y^2 + z^2 - 6x - 14y - 12z + 90 = 0,$
 $x^2 + y^2 + z^2 - 4x - 10y - 8z + 29 = 0.$
- (c) 5 units from the origin and equidistant from $(3, 7, 2)$ and $(-3, -7, -2)$.
 $\text{Ans. } x^2 + y^2 + z^2 - 25 = 0, 3x + 7y + 2z = 0.$
- (d) equidistant from $(3, 5, -4)$ and $(-7, 1, 6)$, and also from $(4, -6, 3)$ and $(-2, 8, 5)$.
 $\text{Ans. } 5x + 2y - 5z + 11 = 0, 3x - 7y - z + 8 = 0.$
- (e) equidistant from $(2, 3, 7)$, $(3, -4, 6)$, and $(4, 3, -2)$.
 $\text{Ans. } 2x - 14y - 2z + 1 = 0, x + 7y - 8z + 16 = 0.$

4. What are the equations of the edges of a rectangular parallelepiped whose dimensions are a , b , and c , if three of its faces coincide with the coördinate planes and one vertex lies in $O-XYZ$? in $O-XY'Z$? in $O-X'Y'Z$?

5. What are the equations of the axes of coördinates?

6. The following equations are the equations of curves lying in one of the coördinate planes. What are the equations of the same curves regarded as curves in space?

(a) $y^2 = 4x$.

(e) $x^2 + 4z + 6x = 0$.

(b) $x^2 + z^2 = 16$.

(f) $y^2 - z^2 - 4y = 0$.

(c) $8x^2 - y^2 = 64$.

(g) $yz^2 + z^2 - 6y = 0$.

(d) $4z^2 + 9y^2 = 36$.

(h) $z^2 - 4x^2 + 8z = 0$.

7. Find the equations of the locus of a point which is equally distant from the points $(6, 4, 3)$ and $(6, 4, 9)$, and also from $(-5, 8, 3)$ and $(-5, 0, 3)$, and determine the nature of the locus.

Ans. $z = 6, y = 4$.

8. Find the equations of the locus of a point which is equally distant from the points $(3, 7, -4)$, $(-5, 7, -4)$, and $(-5, 1, -4)$, and determine the nature of the locus.

Ans. $x = -1, y = 4$.

148. Locus of one equation. Second fundamental problem.

The locus of one equation in three variables (one or two may be lacking) representing coördinates in space is the *surface* passing through all points whose coördinates satisfy that equation and through such points only.

The coördinates of points on the surface may be obtained as follows:

Solve the equation for one of the variables, say z , assume pairs of values of x and y , and compute the corresponding values of z .

A rough model of the surface might then be constructed by taking a thin board for the XY -plane, sticking needles into it at the assumed points (x, y) whose lengths are the computed values of z , and stretching a sheet of rubber over their extremities.

The second fundamental problem, namely, of constructing the locus, is usually discarded in space on account of the mechanical difficulties involved.

149. Locus of two equations. Second fundamental problem.

The locus of two equations in three variables representing coördinates in space is the *curve* passing through all points whose coördinates satisfy both equations and through such points only.

The coördinates of points on the curve may be obtained as follows:

Solve the equations for two of the variables, say x and y , in terms of the third, z , assume values for z , and compute the corresponding values of x and y .

150. Discussion of the equations of a curve. Third fundamental problem. The discussion of curves in Elementary Analytic Geometry is largely confined to curves which lie entirely in a plane which is usually parallel to one of the coördinate planes. Such a curve is defined as the intersection of a given surface with a plane parallel to one of the coördinate planes. The method of determining its nature is illustrated in

Ex. 1. Determine the nature of the curve in which the plane $z = 4$ intersects the surface whose equation is $y^2 + z^2 = 4x$.

Solution. The equations of the curve are, by definition,

$$(1) \quad y^2 + z^2 = 4x, \quad z = 4.$$

Eliminate z by substituting from the second equation in the first. This gives

$$(2) \quad y^2 - 4x + 16 = 0, \quad z = 4.$$

Equations (2) are also the equations of the curve.

For every set of values of (x, y, z) which satisfy both of equations (1) will evidently satisfy both of equations (2), and conversely.

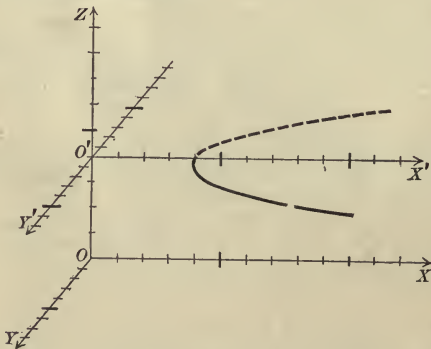

If we take as axes in the plane $z = 4$ the lines $O'X'$ and $O'Y'$ in which the plane cuts the ZX - and YZ -planes, then the equation of the curve when referred to these axes is the first of equations (2), namely,

$$(3) \quad y^2 - 4x + 16 = 0.$$

For the second of equations (2) is satisfied by all points in the plane of $X', O',$ and Y' , and the first of equations (2) is satisfied by the points in that plane lying on the curve (3), because the values of the first two coördinates of a point are evidently the same when referred to the axes $O'X', O'Y',$ and $O'Z$ as when referred to the axes $OX, OY,$ and OZ .

The locus of (3) is a parabola (Rule, p. 197) whose vertex, in the plane $z = 4$, is the point $(4, 0)$ for which $p = 2$.

The method employed in Ex. 1 enables us to state the

Rule to determine the nature of the curve in which a plane parallel to one of the coördinate planes cuts a given surface.

First step. Eliminate the variable occurring in the equation of the plane from the equations of the plane and surface. The result is the equation of the curve referred to the lines in which the given plane cuts the other two coördinate planes as axes.

Second step. Determine the nature of the curve obtained in the second step by the methods of Plane Analytic Geometry.

PROBLEMS

1. Determine the nature of the following curves and construct their loci.

- | | |
|------------------------------------|-----------------------------------------|
| (a) $x^2 - 4y^2 = 8z, z = 8.$ | (e) $x^2 + 4y^2 + 9z^2 = 36, y = 1.$ |
| (b) $x^2 + 9y^2 = 9z^2, z = 2.$ | (f) $x^2 - 4y^2 + z^2 = 25, x = -3.$ |
| (c) $x^2 - 4y^2 = 4z, y = -2.$ | (g) $x^2 - y^2 - 4z^2 + 6x = 0, x = 2.$ |
| (d) $x^2 + y^2 + z^2 = 25, x = 3.$ | (h) $y^2 + z^2 - 4x + 8 = 0, y = 4.$ |

2. Construct the curves in which each of the following surfaces intersect the coördinate planes.

- | | |
|--------------------------------|-------------------------------|
| (a) $x^2 + 4y^2 + 16z^2 = 64.$ | (d) $x^2 + 9y^2 = 10z.$ |
| (b) $x^2 + 4y^2 - 16z^2 = 64.$ | (e) $x^2 - 9y^2 = 10z.$ |
| (c) $x^2 - 4y^2 - 16z^2 = 64.$ | (f) $x^2 + 4y^2 - 16z^2 = 0.$ |

3. Show that the curves of intersection of each of the surfaces in problem 2 with a system of planes parallel to one of the coördinate planes are similar conics. In what cases must this statement be modified?

4. Determine the nature of the intersection of the surface $x^2 + y^2 + 4z^2 = 64$ with the plane $z = k$. How does the curve change as k increases from 0 to 4? from -4 to 0? What idea of the appearance of the surface is thus obtained?

5. Determine the nature of the intersection of the surface $4x - 2y = 4$ with the plane $y = k$; with the plane $z = k'$. How does the intersection change as k or k' changes? What idea of the form of the surface is obtained?

151. Discussion of the equation of a surface. Third fundamental¹ problem.

Theorem III. *The locus of an algebraic equation passes through the origin if there is no constant term in the equation.*

The proof is analogous to that of Theorem VI, p. 73.

Theorem IV. *If the locus of an equation is unaffected by changing the sign of one variable throughout its equation, then the locus is symmetrical with respect to the coördinate plane from which that variable is measured.*

If the locus is unaffected by changing the signs of two variables throughout its equation, it is symmetrical with respect to the axis along which the third variable is measured.

If the locus is unaffected by changing the signs of all three variables throughout its equation, it is symmetrical with respect to the origin.

The proof is analogous to that of Theorem IV, p. 72.

Rule to find the intercepts of a surface on the axes of coördinates.

Set each pair of variables equal to zero and solve for real values of the third.

The curves in which a surface intersects the coördinate planes are called its **traces** on the coördinate planes. From the first step of the Rule, p. 345, it is seen that

The equations of the traces of a surface are obtained by successively setting $x = 0$, $y = 0$, and $z = 0$ in the equation of the surface.

By these means we can determine some properties of the surface. The *general appearance of a surface* is determined by considering the curves in which it is cut by a system of planes parallel to each of the coördinate planes (Rule, p. 345). This also enables us to

determine whether the surface is closed or recedes to infinity.

Ex. 1. Discuss the locus of the equation $y^2 + z^2 = 4x$.

Solution. 1. The surface passes through the origin since there is no constant term in its equation.

2. The surface is symmetrical with respect to the XY -plane, the ZX -plane, and the X -axis.

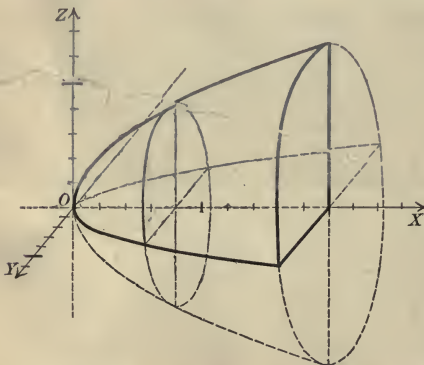

For the locus of the given equation is unaffected by changing the sign of z , of y , or of both together.

3. It cuts the axes at the origin only.
4. Its traces are respectively the point-circle $y^2 + z^2 = 0$ and the parabolas $z^2 = 4x$ and $y^2 = 4x$.
5. It intersects the plane $x = k$ in the curve (Rule, p. 345)

$$y^2 + z^2 = 4k.$$

This curve is a circle whose center is the origin, that is, is on the X -axis, and whose radius is $2\sqrt{k}$ if $k > 0$, but there is no locus if $k < 0$. Hence the surface lies entirely to the right of the YZ -plane.

If k increases from zero to infinity, the radius of the circle increases from zero to infinity while the plane $x = k$ recedes from the YZ -plane.

The intersection of a plane $z = k$ or $y = k'$, parallel to the XY - or ZX -plane, is seen (Rule, p. 345) to be a parabola whose equation is (compare Ex. 1, p. 344)

$$y^2 = 4x - k^2 \quad \text{or} \quad z^2 = 4x - k'^2.$$

These parabolas are found to have the same value of p , namely, $p = 2$, and their vertices recede from the YZ - or ZX -plane as k or k' increases numerically.

PROBLEMS

1. Discuss the loci of the following equations.

(a) $x^2 + z^2 = 4x$.

(f) $x^2 + y^2 - z^2 = 0$.

(b) $x^2 + y^2 + 4z^2 = 16$.

(g) $x^2 - y^2 - z^2 = 9$.

(c) $x^2 + y^2 - 4z^2 = 16$.

(h) $x^2 + y^2 - z^2 + 2xy = 0$.

(d) $6x + 4y + 3z = 12$.

(i) $x + y - 6z = 6$.

(e) $3x + 2y + z = 12$.

(j) $y^2 + z^2 = 25$.

2. Show that the locus of $Ax + By + Cz + D = 0$ is a plane by considering its traces on the coördinate planes and the sections made by a system of planes parallel to one of the coördinate planes.

3. Find the equation of the locus of a point which is equally distant from the point $(2, 0, 0)$ and the YZ -plane and discuss the locus.

$$\text{Ans. } y^2 + z^2 - 4x + 4 = 0.$$

4. Find the equation of the locus of a point whose distance from the point $(0, 0, 3)$ is twice its distance from the XY -plane and discuss the locus.

$$\text{Ans. } x^2 + y^2 - 3z^2 - 6z + 9 = 0.$$

5. Find the equation of the locus of a point whose distance from the point $(0, 4, 0)$ is three fifths its distance from the ZX -plane and discuss the locus.

$$\text{Ans. } 25x^2 + 16y^2 + 25z^2 - 200y + 400 = 0.$$

CHAPTER XVIII

THE PLANE AND THE GENERAL EQUATION OF THE FIRST DEGREE IN THREE VARIABLES

152. The normal form of the equation of the plane. Let ABC be any plane, and let ON be drawn from the origin perpendicular to ABC at D . Let the positive direction on ON be from O toward N , that is, from the origin toward the plane, and

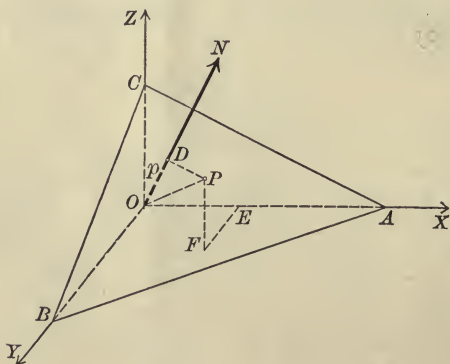

denote the directed length OD by p and the direction angles of ON (p. 330) by α , β , and γ . Then the position of any plane is determined by given positive values of p , α , β , and γ .

Conversely, a given plane determines a single set of positive values of p , α , β , and γ unless $p = 0$. If $p = 0$, the positive direction on ON becomes meaningless. If $p = 0$, we shall suppose that ON is directed upward, and hence $\cos \gamma > 0$ since $\gamma < \frac{\pi}{2}$. If the plane passes through OZ , then ON lies in the XY -plane and $\cos \gamma = 0$; in this case we shall suppose ON so directed that $\beta < \frac{\pi}{2}$ and hence $\cos \beta > 0$. Finally, if the plane coincides with the YZ -plane, the positive direction on ON shall be that on OX .

Theorem I. Normal form. *The equation of a plane is*

$$(I) \quad x \cos \alpha + y \cos \beta + z \cos \gamma - p = 0,$$

where p is the perpendicular distance from the origin to the plane, and α , β , and γ are the direction cosines of that perpendicular.

Proof. Let $P(x, y, z)$ be any point on the given plane ABC . Project O on EF and OP on the line ON . By Theorem II, p. 328,

$$\text{proj. of } OE + \text{proj. of } EF + \text{proj. of } FP = \text{proj. of } OP.$$

Then by Theorem I, p. 328, and by the definition, p. 29,

$$x \cos \alpha + y \cos \beta + z \cos \gamma = p.$$

Transposing, we obtain (I).

Q.E.D.

Corollary. *The equation of any plane is of the first degree in x , y , and z .*

153. The general equation of the first degree, $Ax + By + Cz + D = 0$.

Theorem II. (Converse of the Corollary.) *The locus of the general equation of the first degree in x , y , and z ,*

$$(II) \quad Ax + By + Cz + D = 0,$$

is a plane.

Proof. We shall prove the theorem by showing that (II) may be reduced to the form (I) by multiplying by a proper constant. To determine this constant, multiply (II) by k , which gives

$$(1) \quad kAx + kB y + kCz + kD = 0.$$

Equating corresponding coefficients of (1) and (I), we get

$$(2) \quad kA = \cos \alpha, \quad kB = \cos \beta, \quad kC = \cos \gamma, \quad kD = -p.$$

Squaring the first three of equations (2) and adding,

$$k^2(A^2 + B^2 + C^2) = \cos^2 \alpha + \cos^2 \beta + \cos^2 \gamma = 1.$$

(by (III), p. 330)

$$(3) \quad \therefore k = \frac{1}{\pm \sqrt{A^2 + B^2 + C^2}}.$$

From the last of equations (2) we see that the sign of the radical must be *opposite to that of D* in order that p shall be positive.

If $D = 0$, then $p = 0$; and from the third of equations (2) the sign of the radical must be the *same as that of C*, since when $p = 0$ $\cos \gamma > 0$. If $D = 0$ and $C = 0$, then $p = 0$ and $\cos \gamma = 0$; and from the second of equations (2) the sign of the radical must be the *same as that of B*, since when $p = 0$ and $\cos \gamma = 0$ $\cos \beta > 0$.

Substituting from (3) in (2), we get

$$(4) \begin{cases} \cos \alpha = \frac{A}{\pm \sqrt{A^2 + B^2 + C^2}}, & \cos \beta = \frac{B}{\pm \sqrt{A^2 + B^2 + C^2}}, \\ \cos \gamma = \frac{C}{\pm \sqrt{A^2 + B^2 + C^2}}, & p = \frac{-D}{\pm \sqrt{A^2 + B^2 + C^2}}. \end{cases}$$

We have thus determined values of α , β , γ , and p such that (I) and (II) have the same locus. Hence the locus of (II) is a plane.

Q. E. D.

Corollary I. *The direction cosines of a normal to the plane (II) are respectively A , B , and C each divided by $\pm \sqrt{A^2 + B^2 + C^2}$. The sign of the radical is opposite to that of D , the same as that of C if $D = 0$, the same as that of B if $C = D = 0$, or the same as that of A if $B = C = D = 0$.*

Corollary II. *To reduce the equation of a plane to the normal form divide its equation by $\pm \sqrt{A^2 + B^2 + C^2}$, choosing the sign of the radical as in Corollary I.*

Corollary III. *Two planes whose equations are*

$$Ax + By + Cz + D = 0, \quad A'x + B'y + C'z + D' = 0$$

are parallel when and only when the coefficients of x , y , and z are proportional, that is,

$$\frac{A}{A'} = \frac{B}{B'} = \frac{C}{C'}.$$

For from Corollary I the direction cosines of a normal to (II) are proportional to A , B , and C , and two planes are evidently parallel when and only when their normals are parallel (Corollary, p. 335).

Corollary IV. *Two planes are perpendicular when and only when*

$$AA' + BB' + CC' = 0.$$

This follows from Corollary I by the Corollary on p. 335, since two planes are perpendicular when and only when their normals are perpendicular.

Corollary V. *A plane whose equation has the form*

$Ax + By + D = 0$ is perpendicular to the XY -plane;

$By + Cz + D = 0$ is perpendicular to the YZ -plane;

$Ax + Cz + D = 0$ is perpendicular to the ZX -plane.

That is, if one variable is lacking, the plane is perpendicular to the coordinate plane corresponding to the two variables which occur in the equation.

For these planes are respectively perpendicular to the planes $z = 0$, $x = 0$, and $y = 0$ by Corollary IV.

Corollary VI. *A plane whose equation has the form*

$Ax + D = 0$ is perpendicular to the axis of x ;

$By + D = 0$ is perpendicular to the axis of y ;

$Cz + D = 0$ is perpendicular to the axis of z .

That is, if two variables are lacking, the plane is perpendicular to the axis corresponding to the variable which occurs in the equation.

For by Corollary I two of the direction cosines of the normal to the plane are zero and hence the normal is parallel to one of the axes and the plane is therefore perpendicular to that axis.

PROBLEMS

1. Find the intercepts on the axes and the traces on the coordinate planes of each of the following planes and construct the figures.

(a) $2x + 3y + 4z - 24 = 0.$

(e) $5x - 7y - 35 = 0.$

(b) $7x - 3y + z - 21 = 0.$

(f) $4x + 3z + 36 = 0.$

(c) $9x - 7y - 9z + 63 = 0.$

(g) $5y - 8z - 40 = 0.$

(d) $6x + 4y - z + 12 = 0.$

(h) $3x + 5z + 45 = 0.$

2. Find the equations of the planes and construct them by drawing their traces, for which

(a) $\alpha = \frac{\pi}{4}, \beta = \frac{\pi}{3}, \gamma = \frac{\pi}{3}, p = 6.$

Ans. $\sqrt{2}x + y + z - 12 = 0.$

(b) $\alpha = \frac{2\pi}{3}, \beta = \frac{3\pi}{4}, \gamma = \frac{\pi}{3}, p = 8.$

Ans. $x + \sqrt{2}y - z + 16 = 0.$

(c) $\frac{\cos \alpha}{6} = \frac{\cos \beta}{-2} = \frac{\cos \gamma}{3}, p = 4.$

Ans. $6x - 2y + 3z - 28 = 0.$

(d) $\frac{\cos \alpha}{-2} = \frac{\cos \beta}{-1} = \frac{\cos \gamma}{-2}, p = 2.$

Ans. $2x + y + 2z + 6 = 0.$

3. Find the equation of the plane such that the foot of the perpendicular from the origin to the plane is the point

- (a) $(-3, 2, 6)$. *Ans.* $3x - 2y - 6z + 49 = 0$.
 (b) $(4, 3, -12)$. *Ans.* $4x + 3y - 12z - 169 = 0$.
 (c) $(2, 2, -1)$. *Ans.* $2x + 2y - z - 9 = 0$.

4. Reduce the following equations to the normal form and find α, β, γ , and p .

- (a) $6x - 3y + 2z - 7 = 0$. *Ans.* $\cos^{-1}\frac{6}{7}, \cos^{-1}(-\frac{3}{7}), \cos^{-1}\frac{2}{7}, 1$.
 (b) $x - \sqrt{2}y + z + 8 = 0$. *Ans.* $\frac{2\pi}{3}, \frac{\pi}{4}, \frac{2\pi}{3}, 4$.
 (c) $2x - 2y - z + 12 = 0$. *Ans.* $\cos^{-1}(-\frac{2}{3}), \cos^{-1}\frac{2}{3}, \cos^{-1}\frac{1}{3}, 4$.
 (d) $y - z + 10 = 0$. *Ans.* $\frac{\pi}{2}, \frac{3\pi}{4}, \frac{\pi}{4}, 5\sqrt{2}$.
 (e) $3x + 2y - 6z = 0$. *Ans.* $\cos^{-1}(-\frac{3}{7}), \cos^{-1}(-\frac{2}{7}), \cos^{-1}\frac{6}{7}, 0$.

5. Find the distance from the origin to the plane $12x - 4y + 3z - 39 = 0$.
Ans. 3.

6. Find the distance between the parallel planes $6x + 2y - 3z - 63 = 0$ and $6x + 2y - 3z + 49 = 0$.
Ans. 16.

7. What may be said of the position of the plane (I) if

- (a) $\cos \alpha = 0$? (c) $\cos \gamma = 0$? (e) $\cos \beta = \cos \gamma = 0$?
 (b) $\cos \beta = 0$? (d) $\cos \alpha = \cos \beta = 0$? (f) $\cos \gamma = \cos \alpha = 0$?

8. What are the equations of the traces on the coördinate planes of the plane $Ax + By + Cz + D = 0$?

9. Show that the following pairs of planes are either parallel or perpendicular.

- (a) $\begin{cases} 2x + 5y - 6z + 8 = 0, \\ 6x + 15y - 18z - 5 = 0. \end{cases}$ (c) $\begin{cases} 6x - 3y + 2z - 7 = 0, \\ 3x + 2y - 6z + 28 = 0. \end{cases}$
 (b) $\begin{cases} 3x - 5y - 4z + 7 = 0, \\ 6x + 2y + 2z - 7 = 0. \end{cases}$ (d) $\begin{cases} 14x - 7y - 21z - 50 = 0, \\ 2x - y - 3z + 12 = 0. \end{cases}$

10. For what values of α, β, γ , and p will the locus of (I) be parallel to the XY -plane? the YZ -plane? the ZX -plane? coincide with each of these planes?

11. For what values of α, β, γ , and p will the locus of (I) pass through the X -axis? the Y -axis? the Z -axis?

12. Show that the coördinates of the point of intersection of three planes may be found by solving their equations simultaneously for x, y , and z .

13. Find the coördinates of the point of intersection of the planes $x + 2y + z = 0$, $x - 2y - 8 = 0$, and $x + y + z - 3 = 0$.

Ans. (2, -3, 4).

14. Show that the plane $x + 2y - 2z - 9 = 0$ passes through the point of intersection of the planes $x + y + z - 1 = 0$, $x - y - z - 1 = 0$, and $2x + 3y - 8 = 0$.

15. Show that the four planes $x + y + 2z - 2 = 0$, $x + y - 2z + 2 = 0$, $x - y + 8 = 0$, and $3x - y - 2z + 18 = 0$ pass through the same point.

16. Show that the planes $2x - y + z + 3 = 0$, $x - y + 4z = 0$, $3x + y - 2z + 8 = 0$, $4x - 2y + 2z - 5 = 0$, $9x + 3y - 6z - 7 = 0$, and $7x - 7y + 28z - 6 = 0$ bound a parallelepiped.

17. Show that the planes $6x - 3y + 2z = 4$, $3x + 2y - 6z = 10$, $2x + 6y + 3z = 9$, $3x + 2y - 6z = 0$, $12x + 36y + 18z - 11 = 0$, and $12x - 6y + 4z - 17 = 0$ bound a rectangular parallelepiped.

18. Show that the planes $x + 2y - z = 0$, $y + 7z - 2 = 0$, $x - 2y - z - 4 = 0$, $2x + y - 8 = 0$, and $3x + 3y - z - 8 = 0$ bound a quadrangular pyramid.

19. Derive the conditions for parallelism of two planes from the fact that two planes are parallel if their traces are parallel lines.

154. Planes determined by three conditions. If three of the coefficients of

$$(1) \quad Ax + By + Cz + D = 0$$

are known in terms of the fourth, then the plane is completely determined, for if their values be substituted in (1), the equation may be divided by the fourth coefficient. Three conditions which the plane satisfies will lead to three equations in the coefficients which may be solved for three of the coefficients in terms of the fourth. Hence a plane is, in general, determined by three conditions. Its equation may be obtained by a Rule analogous to that on p. 93, using equation (1) in the first step.

Thus to find the equation of a plane passing through three points we proceed as in Ex. 1, p. 93, using equation (1) in the first step. In the second step three equations involving A , B , C , and D are obtained, which may be solved for three of these coefficients in terms of the fourth.

Ex. 1. Find the equation of the plane which passes through the point $P_1(2, -7, \frac{3}{2})$ and is parallel to the plane $21x - 12y + 28z - 84 = 0$.

Solution. Let the equation of the required plane be

$$(2) \quad Ax + By + Cz + D = 0.$$

Since P_1 lies on (2),

$$(3) \quad 2A - 7B + \frac{3}{2}C + D = 0,$$

and since (2) is parallel to the given plane (Corollary III, p. 350),

$$(4) \quad \frac{A}{21} = \frac{B}{-12} = \frac{C}{28}.$$

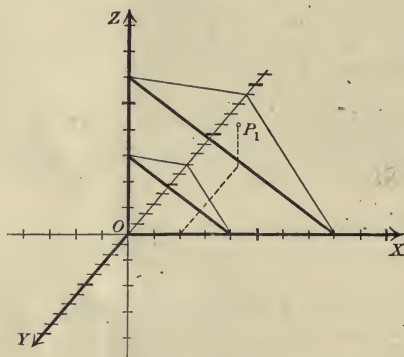

Solving (3) and (4) for A , B , and D in terms of C , we get

$$A = \frac{3}{4}C, \quad B = -\frac{3}{2}C, \quad D = -6C.$$

Substituting in (2), we obtain

$$\frac{3}{4}Cx - \frac{3}{2}Cy + Cz - 6C = 0.$$

Clearing of fractions and dividing by C ,

$$21x - 12y + 28z - 168 = 0.$$

PROBLEMS

✓ 1. Find the equation of the plane which passes through the points $(2, 3, 0)$, $(-2, -3, 4)$, and $(0, 6, 0)$. *Ans.* $3x + 2y + 6z - 12 = 0$.

✓ 2. Find the equation of the plane which passes through the points $(1, 1, -1)$, $(-2, -2, 2)$, and $(1, -1, 2)$. *Ans.* $x - 3y - 2z = 0$.

✓ 3. Find the equation of the plane which passes through the point $(3, -3, 2)$ and is parallel to the plane $3x - y + z - 6 = 0$.

$$\text{Ans. } 3x - y + z - 14 = 0.$$

4. Find the equation of the plane which passes through the points (0, 3, 0) and (4, 0, 0) and is perpendicular to the plane $4x - 6y - z = 12$.

$$\text{Ans. } 3x + 4y - 12z - 12 = 0.$$

5. Find the equation of the plane which passes through the point (0, 0, 4) and is perpendicular to each of the planes $2x - 3y = 5$ and $x - 4z = 3$.

$$\text{Ans. } 12x + 8y + 3z - 12 = 0.$$

6. Find the equation of the plane whose intercepts on the axes are 3, 5, and 4.

$$\text{Ans. } 20x + 12y + 15z - 60 = 0.$$

7. Find the equation of the plane which passes through the point (2, -1, 6) and is parallel to the plane $x - 2y - 3z + 4 = 0$.

$$\text{Ans. } x - 2y - 3z + 14 = 0.$$

8. Find the equation of the plane which passes through the points (2, -1, 6) and (1, -2, 4) and is perpendicular to the plane $x - 2y - 2z + 9 = 0$.

$$\text{Ans. } 2x + 4y - 3z + 18 = 0.$$

9. Find the equation of the plane whose intercepts are -1, -1, and 4.

$$\text{Ans. } 4x + 4y - z + 4 = 0.$$

10. Find the equation of the plane which passes through the point (4, -2, 0) and is perpendicular to the planes $x + y - z = 0$ and $2x - 4y + z = 5$.

$$\text{Ans. } x + y + 2z - 2 = 0.$$

11. Show that the four points (2, -3, 4), (1, 0, 2), (2, -1, 2), and (1, -1, 3) lie in a plane.

12. Show that the four points (1, 0, -1), (3, 4, -3), (8, -2, 6), and (2, 2, -2) lie in a plane.

13. Find the equation of the plane which is perpendicular to the line joining (3, 4, -1) to (5, 2, 7) at its middle point.

$$\text{Ans. } x - y + 4z - 13 = 0.$$

14. Find the equations of the faces of the tetrahedron whose vertices are the points (0, 3, 1), (2, -7, 1), (0, 5, -4), and (2, 0, 1).

$$\text{Ans. } 25x + 5y + 2z = 17, 5x - 2z = 8, z = 1, 15x + 10y + 4z = 34.$$

15. The equations of three faces of a parallelepiped are $x - 4y = 3$, $2x - y + z = 3$, and $3x + y - 2z = 0$, and one vertex is the point (3, 7, -2). What are the equations of the other three faces?

$$\text{Ans. } x - 4y + 25 = 0, 2x - y + z + 3 = 0, 3x + y - 2z = 20.$$

16. Find the equation of the plane whose intercepts are a , b , c .

$$\text{Ans. } \frac{x}{a} + \frac{y}{b} + \frac{z}{c} = 1.$$

17. What are the equations of the traces of the plane in problem 16? How might these equations have been anticipated from Plane Analytic Geometry?

18. Find the equation of the plane which passes through the point $P_1(x_1, y_1, z_1)$ and is parallel to the plane $A_1x + B_1y + C_1z + D_1 = 0$.

$$\text{Ans. } A_1(x - x_1) + B_1(y - y_1) + C_1(z - z_1) = 0.$$

19. Find the equation of the plane which passes through the origin and $P_1(x_1, y_1, z_1)$ and is perpendicular to the plane $A_1x + B_1y + C_1z + D_1 = 0$.

$$\text{Ans. } (B_1z_1 - C_1y_1)x + (C_1x_1 - A_1z_1)y + (A_1y_1 - B_1x_1)z = 0.$$

155. The equation of a plane in terms of its intercepts.

Theorem III. *If a , b , and c are the intercepts of a plane on the X -, Y -, and Z -axes respectively, then the equation of the plane is*

$$(III) \quad \frac{x}{a} + \frac{y}{b} + \frac{z}{c} = 1.$$

Proof. By Theorem II the equation of any plane has the form

$$(1) \quad Ax + By + Cz + D = 0.$$

By the Rule, p. 346, we get

$$a = -\frac{D}{A}, \quad b = -\frac{D}{B}, \quad c = -\frac{D}{C},$$

whence
$$A = -\frac{D}{a}, \quad B = -\frac{D}{b}, \quad C = -\frac{D}{c}.$$

Substituting in (1), dividing by $-D$, and transposing, we obtain (III).

Q. E. D.

Equation (III) should be compared with (VI), p. 96.

156. The distance from a plane to a point. The positive direction on any line perpendicular to a plane is assumed to agree with that on the line drawn through the origin perpendicular to the plane (p. 348). Hence the distance *from* a plane *to* the point P_1 is *positive* or *negative* according as P_1 and the origin are on opposite sides of the plane or not.

If the plane passes through the origin, the sign of the distance from the plane to P_1 must be determined by the conventions for the special cases on p. 348.

Theorem IV. *The distance d from the plane*

$$x \cos \alpha + y \cos \beta + z \cos \gamma - p = 0$$

to the point $P_1(x_1, y_1, z_1)$ is given by

$$(IV) \quad d = x_1 \cos \alpha + y_1 \cos \beta + z_1 \cos \gamma - p.$$

Proof. Projecting OP_1 on ON , we evidently get $p + d$.

Projecting OE , EF , and FP_1 on ON , we get respectively (Theorem I, p. 328) $x_1 \cos \alpha$, $y_1 \cos \beta$, and $z_1 \cos \gamma$.

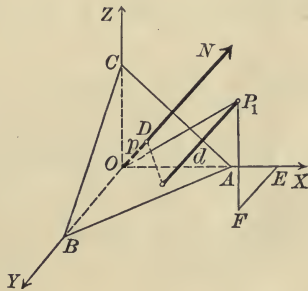

Then by Theorem II, p. 328,

$$p + d = x_1 \cos \alpha + y_1 \cos \beta + z_1 \cos \gamma.$$

$$\therefore d = x_1 \cos \alpha + y_1 \cos \beta + z_1 \cos \gamma - p. \quad \text{Q.E.D.}$$

From Theorem IV we have at once the

Rule to find the distance from a given plane to a given point.

First step. Reduce the equation of the plane to the normal form (Corollary II, p. 350).

Second step. Substitute the coördinates of the given point in the left-hand side of the equation. The result is the required distance.

157. The angle between two planes. The plane angle of one pair of dihedral angles formed by two intersecting planes is evidently equal to the angle between the positive directions of the normals to the planes. That angle is called **the angle between the planes.**

Theorem V. *The angle θ between two planes*

$$A_1x + B_1y + C_1z + D_1 = 0, \quad A_2x + B_2y + C_2z + D_2 = 0$$

is given by

$$(V) \quad \cos \theta = \frac{A_1A_2 + B_1B_2 + C_1C_2}{\pm \sqrt{A_1^2 + B_1^2 + C_1^2} \times \pm \sqrt{A_2^2 + B_2^2 + C_2^2}},$$

the signs of the radicals being chosen as in Corollary I, p. 350.

Proof. By definition the angle between the planes is the angle between their normals.

By (4), p. 350, the direction cosines of the normals to the planes are

$$\cos \alpha_1 = \frac{A_1}{\pm \sqrt{A_1^2 + B_1^2 + C_1^2}}, \quad \cos \alpha_2 = \frac{A_2}{\pm \sqrt{A_2^2 + B_2^2 + C_2^2}},$$

$$\cos \beta_1 = \frac{B_1}{\pm \sqrt{A_1^2 + B_1^2 + C_1^2}}, \quad \cos \beta_2 = \frac{B_2}{\pm \sqrt{A_2^2 + B_2^2 + C_2^2}},$$

$$\cos \gamma_1 = \frac{C_1}{\pm \sqrt{A_1^2 + B_1^2 + C_1^2}}, \quad \cos \gamma_2 = \frac{C_2}{\pm \sqrt{A_2^2 + B_2^2 + C_2^2}}.$$

By (V), p. 334, we have

$$\cos \theta = \cos \alpha_1 \cos \alpha_2 + \cos \beta_1 \cos \beta_2 + \cos \gamma_1 \cos \gamma_2.$$

Substituting the values of the direction cosines of the normals, we obtain (V). Q. E. D.

PROBLEMS

1. Find the distance from the plane

- | | |
|---------------------------------------------------------|--------------------------------|
| (a) $6x - 3y + 2z - 10 = 0$ to the point $(4, 2, 10)$. | Ans. 4. |
| (b) $x + 2y - 2z - 12 = 0$ to the point $(1, -2, 3)$. | Ans. -7. |
| (c) $4x + 3y + 12z + 6 = 0$ to the point $(9, -1, 0)$. | Ans. -3. |
| (d) $2x - 5y + 3z - 4 = 0$ to the point $(-2, 1, 7)$. | Ans. $\frac{4}{19}\sqrt{38}$. |

2. Do the origin and the point $(3, 5, -2)$ lie on the same side of the plane $7x - y - 3z + 6 = 0$? Ans. Yes.

3. Find the distance from the plane $Ax + By + Cz + D = 0$ to the point $P_1(x_1, y_1, z_1)$.

Ans. $\frac{Ax_1 + By_1 + Cz_1 + D}{\pm \sqrt{A^2 + B^2 + C^2}}$.

4. Find the locus of points which are equally distant from the planes $2x - y - 2z - 3 = 0$ and $6x - 3y + 2z + 4 = 0$.

$$\text{Ans. } 32x - 16y - 8z - 9 = 0.$$

5. Find the length of the altitude of the tetraedron whose vertices are $(0, 3, 1)$, $(2, -7, 1)$, $(0, 5, -4)$, and $(2, 0, 1)$ which is drawn from the first vertex.

$$\text{Ans. } \frac{10}{3} \sqrt{29}.$$

6. Find the volume of the tetraedron whose vertices are $(3, 4, 0)$, $(4, -1, 0)$, $(1, 2, 0)$, and $(6, -1, 4)$.

$$\text{Ans. } 8.$$

7. Find the angles between the following pairs of planes.

$$(a) \ 2x + y - 2z - 9 = 0, \ x - 2y + 2z = 0. \quad \text{Ans. } \cos^{-1}\left(-\frac{4}{3}\right).$$

$$(b) \ x + y - 4z = 0, \ 3y - 3z + 7 = 0. \quad \text{Ans. } \cos^{-1}\frac{5}{8}.$$

$$(c) \ 4x + 2y + 4z - 7 = 0, \ 3x - 4y = 0. \quad \text{Ans. } \cos^{-1}\left(-\frac{2}{15}\right).$$

$$(d) \ 2x - y + z = 7, \ x + y + 2z = 11. \quad \text{Ans. } \frac{\pi}{3}.$$

8. Show that the angle given by (V) is that angle formed by the planes which does not contain the origin.

9. Find the vertex and the dihedral angles of that trihedral angle formed by the planes $x + y + z = 2$, $x - y - 2z = 4$, and $2x + y - z = 2$ in which the origin lies.

$$\text{Ans. } (4, -4, 2), \ \cos^{-1}\frac{1}{3}\sqrt{2}, \ \frac{2\pi}{3}, \ \cos^{-1}\left(-\frac{1}{3}\sqrt{2}\right).$$

✓ 10. Find the equation of the plane which passes through the points $(0, -1, 0)$ and $(0, 0, -1)$ and which makes an angle of $\frac{2\pi}{3}$ with the plane $y + z = 7$.

$$\text{Ans. } \pm \sqrt{6}x + y + z + 1 = 0.$$

11. Find the locus of a point which is 3 times as far from the plane $3x - 6y - 2z = 0$ as from the plane $2x - y + 2z = 9$.

$$\text{Ans. } 17x - 13y + 12z - 63 = 0.$$

158. Systems of planes. The equation of a plane which satisfies *two* conditions will, in general, contain an arbitrary constant, for it takes three conditions to determine a plane. Such an equation therefore represents a system of planes.

Systems of planes are used to find the equation of a plane satisfying three conditions in the same manner that systems of lines are used to find the equation of a line satisfying two conditions (Rule, p. 114).

Theorem VI. *The system of planes parallel to a given plane*

$$Ax + By + Cz + D = 0$$

is represented by

$$(VI) \quad Ax + By + Cz + k = 0,$$

where k is an arbitrary constant.

Hint. Show that all of the planes (VI) are parallel to the given plane by Corollary III, p. 350, and that every plane parallel to the given plane is represented by (VI), by finding a value of k for which (VI) passes through a given point P_1 .

Theorem VII. *The system of planes passing through the line of intersection of two given planes*

$$A_1x + B_1y + C_1z + D_1 = 0, \quad A_2x + B_2y + C_2z + D_2 = 0$$

is represented by

$$(VII) \quad A_1x + B_1y + C_1z + D_1 + k(A_2x + B_2y + C_2z + D_2) = 0,$$

where k is an arbitrary constant.

Hint. Show that (VII) passes through any point on the intersection of the given planes, and find a value of k for which (VII) passes through any point not on the intersection.

Theorem VIII. *If the equations of the planes in Theorem VII are in normal form, then $-k$ is the ratio of the distances from those planes to any point in (VII).*

Hint. Let $P_1(x_1, y_1, z_1)$ be any point on the plane

$$x \cos \alpha_1 + y \cos \beta_1 + z \cos \gamma_1 - p_1 + k(x \cos \alpha_2 + y \cos \beta_2 + z \cos \gamma_2 - p_2) = 0.$$

Then $x_1 \cos \alpha_1 + y_1 \cos \beta_1 + z_1 \cos \gamma_1 - p_1 + k(x_1 \cos \alpha_2 + y_1 \cos \beta_2 + z_1 \cos \gamma_2 - p_2) = 0.$

Solve for k and interpret the result by Theorem IV, p. 357.

Corollary. *The equations of the planes bisecting the angles formed by two given planes are found by reducing their equations to the normal form and adding and subtracting them.*

The plane (VII) will lie in the external or internal angles (p. 121) formed by the given planes according as k is positive or negative.

The equation of a system of planes which satisfy a single condition must contain two arbitrary constants. One of the most important systems of this sort is given in

Theorem IX. *The system of planes passing through a given point $P_1(x_1, y_1, z_1)$ is represented by*

$$(IX) \quad A(x - x_1) + B(y - y_1) + C(z - z_1) = 0.$$

Proof. Equation (IX) is the equation of a plane which passes through P_1 , for the coordinates of P_1 satisfy (IX).

If any plane whose equation is

$$Ax + By + Cz + D = 0$$

passes through P_1 , then

$$Ax_1 + By_1 + Cz_1 + D = 0.$$

Subtracting, we get (IX). Hence (IX) represents all planes passing through P_1 . Q. E. D.

Equation (IX) contains two arbitrary constants, namely, the ratio of any two coefficients to the third.

PROBLEMS

- Determine the value of k such that the plane $x + ky - 2z - 9 = 0$ shall
 - pass through the point $(5, -4, -6)$. Ans. 2.
 - be parallel to the plane $6x - 2y - 12z = 7$. Ans. $-\frac{1}{3}$.
 - be perpendicular to the plane $2x - 4y + z = 3$. Ans. 0.
 - be 3 units from the origin. Ans. ± 2 .
 - make an angle of $\frac{\pi}{3}$ with the plane $2x - 2y + z = 0$. Ans. $-\frac{3}{7}\sqrt{35}$.
- Find the equation of the plane which passes through the point $(3, 2, -1)$ and is parallel to the plane $7x - y + z = 14$. Ans. $7x - y + z - 18 = 0$.
- Find the equation of the plane which passes through the intersection of the planes $2x + y - 4 = 0$ and $y + 2z = 0$ and which (a) passes through the point $(2, -1, 1)$; (b) is perpendicular to the plane $3x + 2y - 3z = 6$. Ans. (a) $x + y + z - 2 = 0$; (b) $2x + 3y + 4z - 4 = 0$.
- Find the equations of the planes which bisect the angles formed by the planes $2x - y + 2z = 0$ and $x + 2y - 2z = 6$. Ans. $3x + y - 6 = 0$, $x - 3y + 4z + 6 = 0$.
- Find the equations of the planes passing through the intersection of the planes $2x + y - z = 4$ and $x - y + 2z = 0$ which are perpendicular to the coordinate planes. Ans. $5x + y = 8$, $3x + z = 4$, $3y - 5z = 4$.

6. Find the equations of the planes which bisect the angles formed by the planes $6x - 2y - 3z = 0$ and $4x + 3y - 13z = 10$, and verify by means of (V).

7. Find the equation of the plane passing through the intersection of the planes $A_1x + B_1y + C_1z + D_1 = 0$ and $A_2x + B_2y + C_2z + D_2 = 0$ which passes through the origin.

$$\text{Ans. } (A_1D_2 - A_2D_1)x + (B_1D_2 - A_2D_1)y + (C_1D_2 - C_2D_1)z = 0.$$

8. Find the equations of the planes which bisect the angles formed by the planes $A_1x + B_1y + C_1z + D_1 = 0$ and $A_2x + B_2y + C_2z + D_2 = 0$.

$$\text{Ans. } \frac{A_1x + B_1y + C_1z + D_1}{\sqrt{A_1^2 + B_1^2 + C_1^2}} = \pm \frac{A_2x + B_2y + C_2z + D_2}{\sqrt{A_2^2 + B_2^2 + C_2^2}}.$$

9. Find the equations of the planes passing through the intersection of the planes $A_1x + B_1y + C_1z + D_1 = 0$ and $A_2x + B_2y + C_2z + D_2 = 0$ which are perpendicular to the coordinate planes.

$$\begin{aligned} \text{Ans. } (A_1B_2 - A_2B_1)y - (C_1A_2 - C_2A_1)z + A_1D_2 - A_2D_1 &= 0, \\ (A_1B_2 - A_2B_1)x - (B_1C_2 - B_2C_1)z - (B_1D_2 - B_2D_1) &= 0, \\ (C_1A_2 - C_2A_1)x - (B_1C_2 - B_2C_1)y + C_1D_2 - C_2D_1 &= 0. \end{aligned}$$

10. Find the equation of the plane which passes through $P_1(x_1, y_1, z_1)$ and is perpendicular to the planes

$$A_1x + B_1y + C_1z + D_1 = 0 \text{ and } A_2x + B_2y + C_2z + D_2 = 0.$$

$$\text{Ans. } (B_1C_2 - B_2C_1)(x - x_1) + (C_1A_2 - C_2A_1)(y - y_1) + (A_1B_2 - A_2B_1)(z - z_1) = 0.$$

CHAPTER XIX

THE STRAIGHT LINE IN SPACE

159. General equations of the straight line. A straight line may be regarded as the intersection of any two planes which pass through it. The equations of the planes regarded as simultaneous are the equations of the line of intersection, and hence (Corollary, p. 349)

Theorem I. *The equations of the straight line are of the first degree in x , y , and z .*

Conversely, the locus of two equations of the first degree is a straight line unless the planes which are the loci of the separate equations are parallel. Hence, by Corollary III, p. 350, we have

Theorem II. *The locus of two equations of the first degree,*

$$(II) \quad \begin{cases} A_1x + B_1y + C_1z + D_1 = 0, \\ A_2x + B_2y + C_2z + D_2 = 0, \end{cases}$$

is a straight line unless the coefficients of x , y , and z are proportional.

To plot a straight line we need to know only the coördinates of two points on the line. The easiest points to obtain are usually those lying in the coördinate planes, which we get by setting one of the variables equal to zero and solving for the other two. If a line cuts but one of the coördinate planes, we get only one point in this way, and to plot the line we draw a line through that point parallel to the axis which is perpendicular to that plane.

The direction of a line is known when its direction cosines are known. The method of obtaining these is illustrated in

Ex. 1. Find the direction cosines of the line whose equations are

$$3x + 2y - z - 1 = 0, \quad 2x - y + 2z - 3 = 0.$$

Solution. Let the direction cosines of the line be $\cos \alpha$, $\cos \beta$, and $\cos \gamma$.

The direction cosines of the normals to the planes in which the line lies are respectively (Corollary I, p. 350)

$$\frac{3}{\sqrt{14}}, \frac{2}{\sqrt{14}}, -\frac{1}{\sqrt{14}} \text{ and } \frac{2}{3}, -\frac{1}{3}, \frac{2}{3}.$$

Since the intersection of the two planes is perpendicular to the normals to both, we have (Theorem VI, p. 335)

$$\frac{3}{\sqrt{14}} \cos \alpha + \frac{2}{\sqrt{14}} \cos \beta - \frac{1}{\sqrt{14}} \cos \gamma = 0, \quad \frac{2}{3} \cos \alpha - \frac{1}{3} \cos \beta + \frac{2}{3} \cos \gamma = 0.$$

Solving for $\cos \beta$ and $\cos \gamma$ in terms of $\cos \alpha$, we get

$$\cos \beta = -\frac{3}{8} \cos \alpha, \quad \cos \gamma = -\frac{7}{8} \cos \alpha,$$

and hence
$$\cos \alpha = -\frac{3 \cos \beta}{8} = -\frac{3 \cos \gamma}{7}.$$

Dividing by 3, the least common multiple of the numerators, we get

$$\frac{\cos \alpha}{3} = \frac{\cos \beta}{-8} = \frac{\cos \gamma}{-7}.$$

Then by the Corollary, p. 331,

$$\cos \alpha = \frac{3}{\pm \sqrt{122}}, \quad \cos \beta = \frac{-8}{\pm \sqrt{122}}, \quad \cos \gamma = \frac{-7}{\pm \sqrt{122}}.$$

The line will be directed downward or upward according as the positive or negative sign of the radical is chosen.

The method is general and may be formulated as the

Rule to find the direction cosines of a line whose equations are given.

First step. Find the direction cosines of the normals to the planes in which the line lies (Corollary I, p. 350).

Second step. Find the conditions that the given line is perpendicular to the normals in the first step (Theorem VI, p. 335) and solve for two of the direction cosines of the line in terms of the third.

Third step. Express the results of the third step as a continued proportion and apply the Corollary, p. 331.

Ex. 2. Find the direction cosines of the line whose equations are

$$4x + 3z - 10 = 0, \quad 4x - 2y + 3z - 1 = 0.$$

Solution. First step. The direction cosines of the normals to the given planes are

$$\frac{4}{5}, 0, \frac{3}{5} \text{ and } \frac{4}{\sqrt{29}}, -\frac{2}{\sqrt{29}}, \frac{3}{\sqrt{29}}.$$

Second step. If the direction cosines of the line are $\cos \alpha$, $\cos \beta$, and $\cos \gamma$, then

$$\frac{4}{5} \cos \alpha + \frac{3}{5} \cos \gamma = 0, \quad \frac{4}{\sqrt{29}} \cos \alpha - \frac{2}{\sqrt{29}} \cos \beta + \frac{3}{\sqrt{29}} \cos \gamma = 0,$$

and hence
$$\cos \gamma = -\frac{4}{3} \cos \alpha, \quad \cos \beta = 0.$$

Third step. From these equations $\frac{\cos \alpha}{3} = \frac{\cos \gamma}{-4}$, $\cos \beta = 0$, and hence $\cos \alpha$, $\cos \beta$, and $\cos \gamma$ are proportional to 3, 0, and -4. Then (Corollary, p. 331),

$$\cos \alpha = \pm \frac{3}{5}, \quad \cos \beta = 0, \quad \cos \gamma = \mp \frac{4}{5}.$$

The line will be directed downward or upward according as the upper or lower signs are used.

Theorem III. *If α , β , and γ are the direction cosines of the line (II), then*

$$\frac{\cos \alpha}{B_1 C_2 - B_2 C_1} = \frac{\cos \beta}{C_1 A_2 - C_2 A_1} = \frac{\cos \gamma}{A_1 B_2 - A_2 B_1}.$$

This is proved by the above Rule without carrying out the last part of the third step.

PROBLEMS

1. Find the points in which the following lines pierce the coördinate planes and construct the lines.

(a) $2x + y - z = 2$, $x - y + 2z = 4$. (c) $x + 2y = 8$, $2x - 4y = 7$.

(b) $4x + 3y - 6z = 12$, $4x - 3y = 2$. (d) $y + z = 4$, $x - y + 2z = 10$.

2. Find the direction cosines of the following lines.

(a) $2x - y + 2z = 0$, $x + 2y - 2z = 4$.

Ans. $\pm \frac{2}{\sqrt{65}} \sqrt{65}$, $\mp \frac{6}{\sqrt{65}} \sqrt{65}$, $\mp \frac{1}{\sqrt{65}} \sqrt{65}$.

(b) $x + y + z = 5$, $x - y + z = 3$. *Ans.* $\pm \frac{1}{2} \sqrt{2}$, 0 , $\mp \frac{1}{2} \sqrt{2}$.

(c) $3x + 2y - z = 4$, $x - 2y - 2z = 5$. *Ans.* $\pm \frac{6}{\sqrt{5}} \sqrt{5}$, $\mp \frac{1}{\sqrt{5}} \sqrt{5}$, $\pm \frac{8}{\sqrt{5}} \sqrt{5}$.

(d) $x + y - 3z = 6$, $2x - y + 3z = 3$. *Ans.* 0 , $\pm \frac{3}{\sqrt{10}} \sqrt{10}$, $\pm \frac{1}{\sqrt{10}} \sqrt{10}$.

(e) $x + y = 6$, $2x - 3z = 5$. *Ans.* $\pm \frac{3}{\sqrt{22}} \sqrt{22}$, $\mp \frac{3}{\sqrt{22}} \sqrt{22}$, $\pm \frac{1}{\sqrt{11}} \sqrt{22}$.

(f) $y + 3z = 4$, $3y - 5z = 1$. *Ans.* ± 1 , 0 , 0 .

(g) $2x - 3y + z = 0$, $2x - 3y - 2z = 6$.

Ans. $\pm \frac{3}{\sqrt{13}} \sqrt{13}$, $\pm \frac{2}{\sqrt{13}} \sqrt{13}$, 0 .

(h) $5x - 14z - 7 = 0$, $2x + 7z = 19$. *Ans.* 0 , ± 1 , 0 .

3. Show that the following pairs of lines are parallel and construct the lines.

(a) $2y + z = 0$, $3y - 4z = 7$ and $5y - 2z = 8$, $4y + 11z = 44$.

(b) $x + 2y - z = 7$, $y + z - 2x = 6$ and $3x + 6y - 3z = 8$, $2x - y - z = 0$.

(c) $3x + z = 4$, $y + 2z = 9$ and $6x - y = 7$, $3y + 6z = 1$.

4. Show that the following pairs of lines meet in a point and are perpendicular.

(a) $x + 2y = 1$, $2y - z = 1$ and $x - y = 1$, $x - 2z = 3$.

(b) $4x + y - 3z + 24 = 0$, $z = 5$ and $x + y + 3 = 0$, $x + 2 = 0$.

(c) $3x + y - z = 1$, $2x - z = 2$ and $2x - y + 2z = 4$, $x - y + 2z = 3$.

5. Find the angles between the following lines, assuming that they are directed upward or in front of the ZX -plane.

(a) $x + y - z = 0$, $y + z = 0$ and $x - y = 1$, $x - 3y + z = 0$. *Ans.* $\frac{\pi}{3}$.

(b) $x + 2y + 2z = 1$, $x - 2z = 1$ and $4x + 3y - z + 1 = 0$, $2x + 3y = 0$.
Ans. $\cos^{-1} \frac{1}{2}$.

(c) $x - 2y + z = 2$, $2y - z = 1$ and $x - 2y + z = 2$, $x - 2y + 2z = 4$.
Ans. $\cos^{-1} \frac{1}{2}$.

6. Find the equations of the planes through the line

$$x + y - z = 0, 2x - y + 3z = 5$$

which are perpendicular to the coördinate planes.

Ans. $3x + 2z = 5$, $3y - 5z + 5 = 0$, $5x + 2y = 5$.

7. Show analytically that the intersections of the planes $x - 2y - z = 3$ and $2x - 4y - 2z = 5$ with the plane $x + y - 3z = 0$ are parallel lines.

8. Verify analytically that the intersections of any two parallel planes with a third plane are parallel lines.

160. The projecting planes of a line. The three planes passing through a given line and perpendicular to the coördinate planes are called the **projecting planes** of the line.

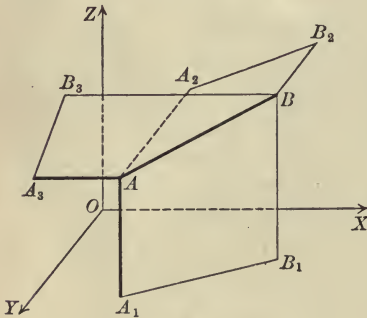

If the line is perpendicular to one of the coördinate planes, any plane containing the line is perpendicular to that plane. In this case we speak of but two projecting planes, namely, those drawn through the line perpendicular to the other coördinate planes.

If the line is parallel to one of the coördinate planes, two of the projecting planes coincide.

By Theorem VII, p. 360, the equation of any plane through the line

$$(1) \quad A_1x + B_1y + C_1z + D_1 = 0, \quad A_2x + B_2y + C_2z + D_2 = 0$$

has the form

$$(2) \quad (A_1 + kA_2)x + (B_1 + kB_2)y + (C_1 + kC_2)z + (D_1 + kD_2) = 0.$$

If (2) is to be perpendicular to the XY -plane, $z = 0$, then (Corollary IV, p. 350) $C_1 + kC_2 = 0$, whence $k = -\frac{C_1}{C_2}$. Substituting in (2) and reducing, we get

$$(3) \quad (C_1A_2 - C_2A_1)x - (B_1C_2 - B_2C_1)y + C_1D_2 - C_2D_1 = 0.$$

Similarly, if (2) is perpendicular to the YZ - or ZX -plane, it becomes

$$(4) \quad (A_1B_2 - A_2B_1)y - (C_1A_2 - C_2A_1)z + A_1D_2 - A_2D_1 = 0,$$

$$(5) \quad (A_1B_2 - A_2B_1)x - (B_1C_2 - B_2C_1)z - (B_1D_2 - B_2D_1) = 0.$$

Equations (3), (4), and (5) are the equations of the projecting planes of the line (1), and any two of them may be used as the equations of the line.

If $A_1B_2 - A_2B_1 \neq 0$, that is, if the line is not parallel to the XY -plane (Theorem III), equations (5) and (4) may be written in the forms

$$x = mz + a, \quad y = nz + b.$$

If $A_1B_2 - A_2B_1 = 0$ and $B_1C_2 - B_2C_1 \neq 0$, that is, if the line is parallel to the XY -plane but is not parallel to the Y -axis, equations (5) and (3) may be written in the forms

$$z = a, \quad y = mx + b.$$

If $A_1B_2 - A_2B_1 = 0$ and $B_1C_2 - B_2C_1 = 0$, that is, if the line is parallel to the Y -axis, equations (4) and (3) may be written in the forms

$$z = a, \quad x = b.$$

Hence we have

Theorem IV. *The equations of a line which pierces the XY -plane, or which is parallel to the XY -plane but not to the Y -axis, or which is parallel to the Y -axis, may be put in the following forms respectively:*

$$(IV) \quad \begin{cases} x = mz + a, \\ y = nz + b, \end{cases} \quad \begin{cases} z = a, \\ y = mx + b, \end{cases} \quad \begin{cases} z = a, \\ x = b. \end{cases}$$

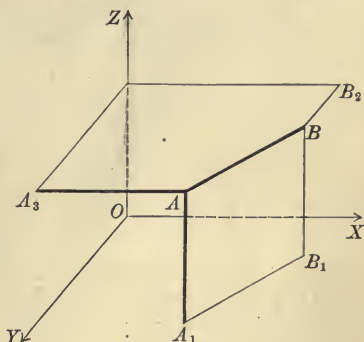
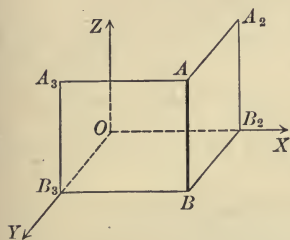

To find the equations of the projecting planes of a given line we may proceed as above by considering the system of planes which pass through the given line (Theorem VII, p. 360) and determining the parameter k so that the plane shall be perpendicular to each of the coordinate planes in turn. These equations may also be found by eliminating z , x , and y in turn from the equations of the line.

To reduce the equations of a given line to one of the forms (IV) we solve them for x and y in terms of z . If there is no solution for x and y (Theorem IV, p. 90), we solve for y and z . Finally, if there is no solution for y and z , we solve them for z and x .

PROBLEMS

1. Find the equations of the projecting planes of the following lines.

(a) $2x + y - z = 0, x - y + 2z = 3.$

Ans. $5x + y = 3, 3x + z = 3, 3y - 5z + 6 = 0.$

(b) $x + y + z = 6, x - y - 2z = 2.$

Ans. $3x + y = 14, 2x - z = 8, 2y + 3z = 4.$

(c) $2x + y - z = 1, x - y + z = 2.$

Ans. $x = 1, y - z + 1 = 0.$

(d) $x + y - 4z = 1, 2x + 2y + z = 0.$

Ans. $9x + 9y = 1, 9z + 2 = 0.$

(e) $2y + 3z = 6, 2y - 3z = 18.$

Ans. $y = 6, z = -2.$

(f) $2x - y + z = 0, 4x + 3y + 2z = 6.$

Ans. $5y = 6, 10x + 5z = 6.$

(g) $x + z = 1, x - z = 3.$

Ans. $x = 2, z = -1.$

2. Reduce the equations of the following lines to one of the forms (IV) and construct the lines.

(a) $x + y - 2z = 0, x - y + z = 4.$

Ans. $x = \frac{1}{2}z + 2, y = \frac{3}{2}z - 2.$

(b) $x + 2y - z = 2, 2x + 4y + 2z = 5.$

Ans. $z = \frac{1}{4}, y = -\frac{1}{2}x + \frac{9}{8}.$

(c) $x - 2y + z = 4, x + 2y - z = 6.$

Ans. $x = 5, y = \frac{1}{2}z + \frac{1}{2}.$

(d) $x + 3z = 6, 2x + 5z = 8.$

Ans. $z = 4, x = -6.$

(e) $x + 2y - 2z = 2, 2x + y - 4z = 1.$

Ans. $x = 2z, y = 1.$

(f) $x - y + z = 3, 3x - 3y + 2z = 6.$

Ans. $z = 3, y = x.$

3. Interpret geometrically the meaning of the constants in each of equations (IV) by determining numbers proportional to the direction cosines of each line and the point in which the first line cuts the XY -plane, the second the YZ -plane, and the third the ZX -plane.

4. Interpret the geometric significance of the constants in equations (IV) by considering the traces of the planes which are the loci of those equations taken separately.

5. Show that a straight line in space is determined by four conditions, and formulate a rule by which to find its equations.

6. Find the equations of the line passing through the points $(-2, 2, 1)$ and $(-8, 5, -2)$.

Ans. $x = 2z - 4, y = -z + 3.$

7. Find the equations of the projection of the line $x = z + 2$, $y = 2z - 4$ upon the plane $x + y - z = 0$. *Ans.* $x = \frac{1}{5}z + \frac{1}{5}4$, $y = \frac{4}{5}z - \frac{1}{5}4$.

8. Find the equations of the projection of the line $z = 2$, $y = x - 2$ upon the plane $x - 2y - 3z = 4$. *Ans.* $x = -5z + 4$, $y = -4z$.

9. Show that the equations of a line may be written in one of the forms

$$\begin{cases} y = mx + a, \\ z = nx + b, \end{cases} \quad \begin{cases} x = a, \\ z = my + b, \end{cases} \quad \begin{cases} x = a, \\ y = b, \end{cases}$$

according as it pierces the YZ -plane, is parallel to the YZ -plane, or is parallel to the Z -axis.

10. Show that the condition that the line $x = mz + a$, $y = nz + b$ should intersect the line $x = m'z + a'$, $y = n'z + b'$ is $\frac{a - a'}{m - m'} = \frac{b - b'}{n - n'}$.

161. Various forms of the equations of a straight line.

Theorem V. Parametric form. *The coördinates of any point $P(x, y, z)$ on the line through a given point $P_1(x_1, y_1, z_1)$ whose direction angles are α , β , and γ are given by*

$$(V) \quad x = x_1 + \rho \cos \alpha, \quad y = y_1 + \rho \cos \beta, \quad z = z_1 + \rho \cos \gamma,$$

where ρ denotes the variable directed length P_1P .

Proof. The projections of P_1P on the axes are respectively (Corollary II, p. 329)

$$x - x_1, \quad y - y_1, \quad z - z_1,$$

or (Theorem I, p. 328)

$$\rho \cos \alpha, \quad \rho \cos \beta, \quad \rho \cos \gamma.$$

Hence

$$x - x_1 = \rho \cos \alpha, \quad y - y_1 = \rho \cos \beta, \quad z - z_1 = \rho \cos \gamma.$$

Solving for x , y , and z , we obtain (V).

Q.E.D.

Theorem VI. Symmetric form. *The equations of the line passing through the point $P_1(x_1, y_1, z_1)$ whose direction angles are α , β , and γ have the form*

$$(VI) \quad \frac{x - x_1}{\cos \alpha} = \frac{y - y_1}{\cos \beta} = \frac{z - z_1}{\cos \gamma}.$$

Hint. Solve each of equations (V) for ρ and equate the values obtained.

Corollary. If $\frac{\cos \alpha}{a} = \frac{\cos \beta}{b} = \frac{\cos \gamma}{c}$, then the symmetric equations of the line may be written in the form

$$\frac{x - x_1}{a} = \frac{y - y_1}{b} = \frac{z - z_1}{c}.$$

Theorem VII. Two-point form. The equations of the straight line passing through $P_1(x_1, y_1, z_1)$ and $P_2(x_2, y_2, z_2)$ are

$$(VII) \quad \frac{x - x_1}{x_2 - x_1} = \frac{y - y_1}{y_2 - y_1} = \frac{z - z_1}{z_2 - z_1}.$$

Proof. The line (VI) passes through P_1 . If it also passes through P_2 , then

$$\frac{x_2 - x_1}{\cos \alpha} = \frac{y_2 - y_1}{\cos \beta} = \frac{z_2 - z_1}{\cos \gamma}.$$

Dividing (VI) by this equation, we obtain (VII). Q. E. D.

Equations (VI) and (VII) each involve three equations, namely, those obtained by neglecting in turn each of the three ratios. These equations are, in different form, the equations of the projecting planes, since one variable is lacking in each (Corollary V, p. 351). Any two of the three equations are independent and may be used as the equations of the line, but all three are usually retained for the sake of their symmetry.

PROBLEMS

1. Find the equations of the lines which pass through the following pairs of points, reduce them to one of the forms (IV), p. 367, and construct the lines.

(a) $(3, 2, -1), (2, -3, 4)$. *Ans.* $x = -\frac{1}{5}z + \frac{14}{5}, y = -z + 1$.

(b) $(1, 6, 3), (3, 2, 3)$.* *Ans.* $z = 3, y = -2x + 8$.

(c) $(1, -4, 2), (3, 0, 3)$. *Ans.* $x = 2z - 3, y = 4z - 12$.

(d) $(2, -2, -1), (3, 1, -1)$. *Ans.* $z = -1, y = 3x - 8$.

(e) $(2, 3, 5), (2, -7, 5)$. *Ans.* $z = 5, x = 2$.

2. Show that the two-point form of the equations of a line become $\frac{x - x_1}{x_2 - x_1} = \frac{y - y_1}{y_2 - y_1}, z = z_1$, if $z_1 = z_2$. What do they become if $y_1 = y_2$? if $x_1 = x_2$?

* From (VII), $\frac{x-1}{3-1} = \frac{y-6}{2-6} = \frac{z-3}{3-3}$. The value of the last ratio is infinite unless $z-3=0$. If $z-3=0$, then the last ratio may have any value and may be equal to the first two. Hence the equations of the line become $\frac{x-1}{2} = \frac{y-6}{-4}, z=3$. Geometrically, it is evident that the two points lie in the plane $z=3$, and hence the line joining them also lies in that plane.

3. What do the two-point equations of a line become if $x_1 = x_2$ and $y_1 = y_2$? if $y_1 = y_2$ and $z_1 = z_2$? if $z_1 = z_2$ and $x_1 = x_2$?

4. Do the following sets of points lie on straight lines?

(a) (3, 2, -4), (5, 4, -6), and (9, 8, -10). Ans. Yes.

(b) (3, 0, 1), (0, -3, 2), and (6, 3, 0). Ans. Yes.

(c) (2, 5, 7), (-3, 8, 1), and (0, 0, 3). Ans. No.

5. Show that the conditions that the three points $P_1(x_1, y_1, z_1)$, $P_2(x_2, y_2, z_2)$, and $P_3(x_3, y_3, z_3)$ should lie on a straight line are $\frac{x_3 - x_1}{x_2 - x_1} = \frac{y_3 - y_1}{y_2 - y_1} = \frac{z_3 - z_1}{z_2 - z_1}$.

6. Find the equations of the line passing through the point (2, -1, -3) whose direction cosines are proportional to 3, 2, and 7, and reduce them to the form (IV), p. 367. Ans. $x = \frac{3}{7}z + \frac{2}{7}$, $y = \frac{2}{7}z - \frac{1}{7}$.

7. Find the equations of the line passing through the point (0, -3, 2) which is parallel to the line joining the points (3, 4, 7) and (2, 7, 5).

$$\text{Ans. } \frac{x}{1} = \frac{y+3}{-3} = \frac{z-2}{2}.$$

8. Show that the lines $\frac{x-2}{3} = \frac{y+2}{-2} = \frac{z}{4}$ and $\frac{x+1}{-3} = \frac{y-5}{2} = \frac{z+3}{-4}$ are parallel.

9. Find the equations of the line through the point (-2, 4, 0) which is parallel to the line $\frac{x}{4} = \frac{y+2}{3} = \frac{z-4}{-1}$, and reduce them to the form (IV), p. 367. Ans. $x = -4z - 2$, $y = -3z + 4$.

10. Show that the lines $\frac{x+2}{6} = \frac{y-3}{-3} = \frac{z-1}{2}$ and $\frac{x-3}{2} = \frac{y}{6} = \frac{z+3}{3}$ are perpendicular.

11. Find the angle between the lines $\frac{x-3}{2} = \frac{y+1}{1} = \frac{z-3}{-1}$ and $\frac{x+2}{1} = \frac{y-7}{2} = \frac{z}{1}$ if both are directed upward. Ans. $\frac{2\pi}{3}$.

12. Find the parametric equations of the line passing through the point (2, -3, 4) whose direction cosines are proportional to 1, -2, and 2.

$$\text{Ans. } x = 2 + \frac{1}{3}\rho, y = -3 - \frac{2}{3}\rho, z = 4 + \frac{2}{3}\rho.$$

13. Construct the lines whose parametric equations are

$$(a) x = 2 + \frac{2}{3}\rho, y = 4 - \frac{1}{3}\rho, z = 6 + \frac{2}{3}\rho.$$

$$(b) x = -3 - \frac{2}{7}\rho, y = 6 - \frac{6}{7}\rho, z = 4 + \frac{3}{7}\rho.$$

14. Find the distance, measured along the line $x = 2 - \frac{3}{13}\rho, y = 4 + \frac{12}{13}\rho, z = -3 + \frac{4}{13}\rho$, from the point (2, 4, -3) to the intersection of the line with the plane $4x - y - 2z = 6$. Ans. $1\frac{5}{8}$.

15. Show that the symmetric equations of the straight line become $\frac{x-x_1}{\cos \alpha} = \frac{y-y_1}{\cos \beta}, z = z_1$ if $\cos \gamma = 0$. What do they become if $\cos \alpha = 0$? if $\cos \beta = 0$?

16. Show that the symmetric equations of the straight line become $z = z_1$, $x = x_1$ if $\cos \gamma = \cos \alpha = 0$. What do they become if $\cos \alpha = \cos \beta = 0$? if $\cos \beta = \cos \gamma = 0$?

17. Reduce the equations of the following lines to the symmetric form.

(a) $x - 2y + z = 8$, $2x - 3y = 13$. Ans. $\frac{x-2}{3} = \frac{y+3}{2} = \frac{z}{1}$.

(b) $4x - 5y + 3z = 3$, $4x - 5y + z + 9 = 0$. Ans. $\frac{x}{5} = \frac{y-3}{4}$, $z = 6$.

(c) $2x + z + 5 = 0$, $x + 3z - 5 = 0$. Ans. $z = 3$, $x = -4$.

(d) $x + 2y + 6z = 5$, $3x - 2y - 10z = 7$. Ans. $\frac{x-3}{2} = \frac{y-1}{-7} = \frac{z}{2}$.

(e) $3x - y - 2z = 0$, $6x - 3y - 4z + 9 = 0$. Ans. $\frac{x-3}{2} = \frac{z}{3}$, $y = 9$.

(f) $3x - 4y = 7$, $x + 3y = 11$. Ans. $x = 5$, $y = 2$.

(g) $2x + y + 2z = 7$, $x + 3y + 6z = 11$. Ans. $\frac{y-3}{2} = \frac{z}{-1}$, $x = 2$.

(h) $2x - 3y + z = 4$, $4x - 6y - z = 5$. Ans. $\frac{x}{3} = \frac{y+1}{2}$, $z = 1$.

(i) $3z + y = 1$, $4z - 3y = 10$. Ans. $y = -2$, $z = 1$.

(j) $x = mz + a$, $y = nz + b$. Ans. $\frac{x-a}{m} = \frac{y-b}{n} = \frac{z}{1}$.

Hint. Find the coordinates of a point on the line by assuming a value of one variable and solving the equations of the line for the other two variables. In the answers this point is the point in which the line pierces the XY -plane, or the point in which it pierces the YZ -plane if it is parallel to the XY -plane, or the point in which it pierces the ZX -plane if it is parallel to the Y -axis.

Find the direction cosines of the line by the Rule, p. 364 (or numbers proportional to them by Theorem III, p. 365), and substitute in the symmetric equations of the line (or in the form given in the Corollary to Theorem VI).

If one or two of the direction cosines are zero, the symmetric equations take the forms given in problems 15 and 16.

18. Find the equations of the line passing through the point $(2, 0, -2)$ which is perpendicular to each of the lines $\frac{x-3}{2} = \frac{y}{1} = \frac{z+1}{2}$ and $\frac{x}{3} = \frac{y+1}{-1} = \frac{z+2}{2}$.

Ans. $\frac{x-2}{4} = \frac{y}{2} = \frac{z+2}{-5}$.

19. Find the equations of the line passing through the point $(3, -1, 2)$ which is perpendicular to each of the lines $x = 2z - 1$, $y = z + 3$, and $\frac{x}{2} = \frac{y}{3} = \frac{z}{4}$.

Ans. $\frac{x-3}{1} = \frac{y+1}{-6} = \frac{z-2}{4}$.

20. Find the equations of the line through $P_1(x_1, y_1, z_1)$ parallel to

(a) $\frac{x - x_2}{a} = \frac{y - y_2}{b} = \frac{z - z_2}{c}$. *Ans.* $\frac{x - x_1}{a} = \frac{y - y_1}{b} = \frac{z - z_1}{c}$.

(b) $x = mz + a, y = nz + b$. *Ans.* $\frac{x - x_1}{m} = \frac{y - y_1}{n} = \frac{z - z_1}{1}$.

(c) $z = a, y = mx + b$. *Ans.* $\frac{x - x_1}{1} = \frac{y - y_1}{m}, z = z_1$.

(d) $A_1x + B_1y + C_1z + D_1 = 0, A_2x + B_2y + C_2z + D_2 = 0$.

Ans. $\frac{x - x_1}{B_1C_2 - B_2C_1} = \frac{y - y_1}{C_1A_2 - A_2C_1} = \frac{z - z_1}{A_1B_2 - A_2B_1}$.

21. Find the equations of the line passing through $P_1(x_1, y_1, z_1)$ which is perpendicular to each of the lines

$\frac{x - x_2}{a_2} = \frac{y - y_2}{b_2} = \frac{z - z_2}{c_2}$ and $\frac{x - x_3}{a_3} = \frac{y - y_3}{b_3} = \frac{z - z_3}{c_3}$.

Ans. $\frac{x - x_1}{b_2c_3 - b_3c_2} = \frac{y - y_1}{c_2a_3 - c_3a_2} = \frac{z - z_1}{a_2b_3 - a_3b_2}$.

162. Relative positions of a line and plane. If the equations of a line have the general form (II), p. 363, then the line will lie in a given plane if a value of k in (VII), p. 360, may be found such that the locus of that equation is the given plane.

If the equations of the line have the form (IV), we substitute the values of two of the variables given by (IV) in the equation of the plane and see whether the result is true for *all* values of the third variable. If such is the case, the line lies in the plane.

An analogous procedure may be followed if the equations of the line have the form (V), (VI), or (VII).

Theorem VIII. *A line whose direction angles are $\alpha, \beta,$ and γ and the plane $Ax + By + Cz + D = 0$ are*

(a) *parallel when and only when*

$$A \cos \alpha + B \cos \beta + C \cos \gamma = 0;$$

(b) *perpendicular when and only when*

$$\frac{A}{\cos \alpha} = \frac{B}{\cos \beta} = \frac{C}{\cos \gamma}.$$

Proof. The direction cosines of the normal to the plane are (Corollary I, p. 350)

$$\frac{A}{\pm \sqrt{A^2 + B^2 + C^2}}, \frac{B}{\pm \sqrt{A^2 + B^2 + C^2}}, \frac{C}{\pm \sqrt{A^2 + B^2 + C^2}}.$$

The line and plane are parallel when and only when the line is perpendicular to the normal to the plane,* that is (Theorem VI, p. 335), when and only when

$$\frac{A \cos \alpha + B \cos \beta + C \cos \gamma}{\pm \sqrt{A^2 + B^2 + C^2}} = 0.$$

Multiplying by the radical, we get the condition for parallelism.

The line and plane are perpendicular when and only when the line is parallel to the normal to the plane, that is (Theorem VI, p. 335), when and only when

$$\cos \alpha = \frac{A}{\pm \sqrt{A^2 + B^2 + C^2}}, \quad \cos \beta = \frac{B}{\pm \sqrt{A^2 + B^2 + C^2}},$$

$$\cos \gamma = \frac{C}{\pm \sqrt{A^2 + B^2 + C^2}}.$$

Dividing these equations by A , B , and C respectively and inverting, we at once obtain the conditions for perpendicularity.

Q. E. D.

163. Geometric interpretation of the solution of three equations of the first degree. The coördinates of a point which lies on each of three planes will satisfy the equations of the three planes, and hence to each point common to three planes there will correspond a solution of their equations. Hence we have the following correspondence between the relative positions of three planes and the number of solutions of their equations.

<i>Position of planes</i>	<i>Number of solutions of equations</i>
Forming a trihedral angle.	One solution.
Forming a prismatic surface.†	No solution.
Passing through the same line.‡	A singly infinite number.§
Three parallel planes.‡	No solution.
Three coincident planes.	A doubly infinite number.

* If the line is perpendicular to the normal to the plane, it may, in a special case, lie in the plane.

† Two of the planes may be parallel in a special case.

‡ Two of the planes may coincide in a special case.

§ The solution contains *one* arbitrary constant.

|| The solution contains *two* arbitrary constants.

If the three planes form a triedral angle, the point of intersection is found without difficulty by solving their equations.

If the three planes form a prismatic surface, their lines of intersection are parallel. Whether this is the case or not may be determined by Theorem III, p. 365, and the Corollary, p. 331.

If the three planes pass through the same line, the intersection of two planes lies in the third. Whether this is the case or not may be determined by the method on p. 373. To solve their equations set one variable equal to k and solve two of the equations for the remaining variables. The results will be solutions for all values of k .

Whether the three planes are parallel or not may be determined by Corollary III, p. 350.

If the three planes coincide, all of their coefficients are proportional. To solve their equations set two of the variables equal to k_1 and k_2 , and solve one of the equations for the remaining variable. The results will be solutions for all values of k_1 and k_2 .

PROBLEMS

1. Show that the line $\frac{x+3}{2} = \frac{y-4}{-7} = \frac{z}{3}$ is parallel to the plane $4x + 2y + 2z = 9$.

2. Show that the line $\frac{x}{3} = \frac{y}{2} = \frac{z}{7}$ is perpendicular to the plane $3x + 2y + 7z = 8$.

3. Show that the line $x = z - 4$, $y = 2z - 3$ lies in the plane $2x - 3y + 4z - 1 = 0$.

4. Show that the line $x = -2 + \frac{2}{3}\rho$, $y = -\frac{2}{3}\rho$, $z = 6 + \frac{1}{3}\rho$ lies in the plane $x - 2y - 6z + 38 = 0$.

5. Find the coördinates of the points of intersection of the following planes and determine the relative positions of the planes.

(a) $2x + y - 2z = 11$, $x - y + z = 0$, $x + 2y - z = 7$.

Ans. (3, 1, -2); planes form a triedral angle.

(b) $2x + 4y + 2z = 3$, $3x + 3y + z = 0$, $3x - 6y - 5z = 8$.

Ans. None; planes form a prismatic surface.

(c) $x - y - 3z = 1$, $x + y + z = 2$, $3x - y - 5z = 4$.

Ans. ($\frac{3}{2} + k$, $\frac{1}{2} - 2k$, k); planes pass through a line.

(d) $3x - y + 5z = 0$, $21x - 7y + 35z = 8$, $2y - 10z - 6x = 4$.

Ans. None; planes are parallel.

(e) $2x - 3y + 4z = 3$, $6y - 4x - 8z + 6 = 0$, $6x - 9y + 12z = 9$.

Ans. [k_1 , k_2 , $\frac{1}{4}(3 - 2k_1 + 3k_2)$]; planes coincide.

6. Show that the line $\frac{x-2}{3} = \frac{y+2}{-1} = \frac{z-3}{4}$ lies in the plane $2x + 2y - z + 3 = 0$.

7. Find the equations of the line passing through the point $(3, 2, -6)$ which is perpendicular to the plane $4x - y + 3z = 5$.

$$\text{Ans. } \frac{x-3}{4} = \frac{y-2}{-1} = \frac{z+6}{3}.$$

8. Find the equations of the line passing through the point $(4, -6, 2)$ which is perpendicular to the plane $x + 2y - 3z = 8$.

$$\text{Ans. } \frac{x-4}{1} = \frac{y+6}{2} = \frac{z-2}{-3}.$$

9. Find the equations of the line passing through the point $(-2, 3, 2)$ which is parallel to each of the planes $3x - y + z = 0$ and $x - z = 0$.

$$\text{Ans. } \frac{x+2}{1} = \frac{y-3}{4} = \frac{z-2}{1}.$$

10. Find the equation of the plane passing through the point $(1, 3, -2)$ which is perpendicular to the line $\frac{x-3}{2} = \frac{y-4}{5} = \frac{z}{-1}$.

$$\text{Ans. } 2x + 5y - z = 19.$$

11. Find the equation of the plane passing through the point $(2, -2, 0)$ which is perpendicular to the line $z = 3, y = 2x - 4$. *Ans.* $x + 2y + 2z = 0$.

12. Find the equation of the plane passing through the line $x + 2z = 4, y - z = 8$ which is parallel to the line $\frac{x-3}{2} = \frac{y+4}{3} = \frac{z-7}{4}$.

$$\text{Ans. } x + 10y - 8z - 84 = 0.$$

13. Find the equation of the plane passing through the point $(3, 6, -12)$ which is parallel to each of the lines $\frac{x+3}{3} = \frac{y-2}{-1} = \frac{z+1}{3}$ and $\frac{x-4}{2} = \frac{z+2}{4}, y = 3$.

$$\text{Ans. } 2x + 3y - z = 36.$$

14. Find the equations of the line passing through the point $(3, 1, -2)$ which is perpendicular to the plane $2x - y - 5z = 6$.

$$\text{Ans. } x = -\frac{2}{3}z + \frac{11}{3}, y = \frac{1}{3}z + \frac{7}{3}.$$

15. Show that the lines $\frac{x-2}{3} = \frac{y+1}{4} = \frac{z}{-2}$ and $\frac{x-2}{-1} = \frac{y+1}{3} = \frac{z}{2}$ intersect, and find the equation of the plane determined by them.

$$\text{Ans. } 14x - 4y + 13z = 32.$$

16. Find the equation of the plane determined by the line $\frac{x-2}{2} = \frac{y+3}{-2} = \frac{z-1}{1}$ and the point $(0, 3, -4)$.

$$\text{Ans. } x + 2y + 2z + 2 = 0.$$

17. Find the equation of the plane determined by the parallel lines $\frac{x+1}{3} = \frac{y-2}{2} = \frac{z}{1}$ and $\frac{x-3}{3} = \frac{y+4}{2} = \frac{z-1}{1}$.

$$\text{Ans. } 8x + y - 26z + 6 = 0.$$

18. Find the equations of the line passing through $P_1(x_1, y_1, z_1)$ which is perpendicular to the plane $Ax + By + Cz + D = 0$.

$$\text{Ans. } \frac{x - x_1}{A} = \frac{y - y_1}{B} = \frac{z - z_1}{C}.$$

19. Find the equation of the plane passing through the point $P_1(x_1, y_1, z_1)$ which is perpendicular to the line $\frac{x - x_2}{a} = \frac{y - y_2}{b} = \frac{z - z_2}{c}$.

$$\text{Ans. } a(x - x_1) + b(y - y_1) + c(z - z_1) = 0.$$

20. Find the angle θ between the line $\frac{x - x_1}{a} = \frac{y - y_1}{b} = \frac{z - z_1}{c}$ and the plane $Ax + By + Cz + D = 0$.

$$\text{Ans. } \sin \theta = \frac{Aa + Bb + Cc}{\sqrt{A^2 + B^2 + C^2} \sqrt{a^2 + b^2 + c^2}}.$$

Hint. The angle between a line and a plane is the acute angle between the line and its projection on the plane. This angle equals $\frac{\pi}{2}$ increased or decreased by the angle between the line and the normal to the plane.

21. Find the equation of the plane passing through $P_3(x_3, y_3, z_3)$ which is parallel to each of the lines $\frac{x - x_1}{a_1} = \frac{y - y_1}{b_1} = \frac{z - z_1}{c_1}$ and $\frac{x - x_2}{a_2} = \frac{y - y_2}{b_2} = \frac{z - z_2}{c_2}$.

$$\text{Ans. } (b_1c_2 - b_2c_1)(x - x_3) + (c_1a_2 - a_2c_1)(y - y_3) + (a_1b_2 - a_2b_1)(z - z_3) = 0.$$

22. Find the condition that the plane $A_1x + B_1y + C_1z + D_1 = 0$ should be parallel to the line $A_2x + B_2y + C_2z + D_2 = 0$, $A_3x + B_3y + C_3z + D_3 = 0$.

$$\text{Ans. } A_1(B_2C_3 - B_3C_2) + B_1(C_2A_3 - C_3A_2) + C_1(A_2B_3 - A_3B_2) = 0.$$

23. Find the equation of the plane determined by the point $P_1(x_1, y_1, z_1)$ and the line $A_1x + B_1y + C_1z + D_1 = 0$, $A_2x + B_2y + C_2z + D_2 = 0$.

$$\begin{aligned} \text{Ans. } & (A_2x_1 + B_2y_1 + C_2z_1 + D_2)(A_1x + B_1y + C_1z + D_1) \\ & = (A_1x_1 + B_1y_1 + C_1z_1 + D_1)(A_2x + B_2y + C_2z + D_2). \end{aligned}$$

24. Find the equation of the plane determined by the intersecting lines $\frac{x - x_1}{a_1} = \frac{y - y_1}{b_1} = \frac{z - z_1}{c_1}$ and $\frac{x - x_2}{a_2} = \frac{y - y_2}{b_2} = \frac{z - z_2}{c_2}$.

$$\text{Ans. } (b_1c_2 - b_2c_1)(x - x_1) + (c_1a_2 - c_2a_1)(y - y_1) + (a_1b_2 - a_2b_1)(z - z_1) = 0.$$

25. Find the equation of the plane determined by the parallel lines $\frac{x - x_1}{a} = \frac{y - y_1}{b} = \frac{z - z_1}{c}$ and $\frac{x - x_2}{a} = \frac{y - y_2}{b} = \frac{z - z_2}{c}$.

$$\begin{aligned} \text{Ans. } & [(y_1 - y_2)c - (z_1 - z_2)b]x + [(z_1 - z_2)a - (x_1 - x_2)c]y \\ & + [(x_1 - x_2)b - (y_1 - y_2)a]z + (y_1z_2 - y_2z_1)a \\ & + (z_1x_2 - z_2x_1)b + (x_1y_2 - x_2y_1)c = 0. \end{aligned}$$

26. Find the conditions that the line $x = mz + a$, $y = nz + b$ should lie in the plane $Ax + By + Cz + D = 0$.

Ans. $Aa + Bb + D = 0$, $Am + Bn + C = 0$.

27. Find the equation of the plane passing through the line $\frac{x - x_1}{a_1} = \frac{y - y_1}{b_1} = \frac{z - z_1}{c_1}$ which is parallel to the line $\frac{x - x_2}{a_2} = \frac{y - y_2}{b_2} = \frac{z - z_2}{c_2}$.

Ans. $(b_1c_2 - b_2c_1)(x - x_1) + (c_1a_2 - c_2a_1)(y - y_1) + (a_1b_2 - a_2b_1)(z - z_1) = 0$.

CHAPTER XX

SPECIAL SURFACES

164. In this chapter we shall consider spheres, cylinders, and cones* (surfaces considered in Elementary Geometry) and surfaces which may be generated by revolving a curve about one of the coordinate axes or by moving a straight line.

165. The sphere.

Theorem I. *The equation of the sphere whose center is the point (α, β, γ) and whose radius is r is*

$$(x - \alpha)^2 + (y - \beta)^2 + (z - \gamma)^2 = r^2, \text{ or}$$

$$(I) \quad x^2 + y^2 + z^2 - 2\alpha x - 2\beta y - 2\gamma z + \alpha^2 + \beta^2 + \gamma^2 - r^2 = 0.$$

Proof. Let $P(x, y, z)$ be any point on the sphere, and denote the center of the sphere by C . Then, by definition, $PC = r$. Substituting the value of PC given by (IV), p. 331, and squaring, we obtain (I). Q. E. D.

Theorem II. *The locus of an equation of the form*

$$(II) \quad x^2 + y^2 + z^2 + Gx + Hy + Iz + K = 0$$

is determined as follows:

(a) *When $G^2 + H^2 + I^2 - 4K > 0$, the locus is a sphere whose center is $\left(-\frac{G}{2}, -\frac{H}{2}, -\frac{I}{2}\right)$ and whose radius is*

$$r = \frac{1}{2}\sqrt{G^2 + H^2 + I^2 - 4K}.$$

(b) *When $G^2 + H^2 + I^2 - 4K = 0$, the locus is the point-sphere† $\left(-\frac{G}{2}, -\frac{H}{2}, -\frac{I}{2}\right)$.*

(c) *When $G^2 + H^2 + I^2 - 4K < 0$, there is no locus.*

* In Analytic Geometry the terms sphere, cylinder, and cone are usually used to denote the spherical surface, cylindrical surface, and conical surface of Elementary Geometry, and not the solids bounded wholly or in part by such surfaces.

† That is, a point or sphere of radius zero.

Proof. Comparing (II) with (I), we obtain

$$-2\alpha = G, \quad -2\beta = H, \quad -2\gamma = I, \quad \alpha^2 + \beta^2 + \gamma^2 - r^2 = K,$$

whence

$$\alpha = -\frac{G}{2}, \quad \beta = -\frac{H}{2}, \quad \gamma = -\frac{I}{2}, \quad r = \frac{1}{2} \sqrt{G^2 + H^2 + I^2 - 4K}.$$

Hence, if $G^2 + H^2 + I^2 - 4K > 0$, the locus is a sphere.

To determine the general appearance of the locus of (II) when $G^2 + H^2 + I^2 - 4K \bar{\geq} 0$, we consider the section formed by the plane $z = k$, whose equation is (Rule, p. 345)

$$(1) \quad x^2 + y^2 + Gx + Hy + k^2 + Ik + K = 0.$$

The discriminant of (1) is (p. 131)

$$\begin{aligned} \Theta &= G^2 + H^2 - 4k^2 - 4Ik - 4K \\ &= -4k^2 - 4Ik + G^2 + H^2 - 4K. \end{aligned}$$

The discriminant of this quadratic in k is (p. 2)

$$\begin{aligned} \Delta &= 16I^2 + 16G^2 + 16H^2 - 64K \\ &= 16(G^2 + H^2 + I^2 - 4K). \end{aligned}$$

In discussing the locus of (1) three cases arise which depend upon the sign of Θ (Theorem I, p. 131).

(a) If $G^2 + H^2 + I^2 - 4K > 0$, Θ is positive for values of k lying between the roots of Θ (Theorem III, p. 11), and the section (1) formed by the plane $z = k$ is a circle. Equation (II) has a locus, as we have seen.

(b) If $G^2 + H^2 + I^2 - 4K = 0$, Θ is negative for all real values of k (Theorem III, p. 11) except the roots, which are real and equal (Theorem II, p. 3), and for this single value of k the locus of (1) is a point-circle. As but one plane, $z = k$, intersects the locus of (II), and as this intersection is a point-circle, the locus is a point which may be regarded as a sphere of zero radius.

(c) If $G^2 + H^2 + I^2 - 4K < 0$, Θ is negative for all real values of k (Theorem III, p. 11). Hence (1) has no locus whatever the value of k may be, and therefore (II) has no locus. Q.E.D.

Theorem III. *The locus of the general equation of the second degree in three variables*

$$(III) \quad Ax^2 + By^2 + Cz^2 + Dyz + Ezx + Fxy + Gx + Hy + Iz + K = 0$$

is a sphere when and only when $A = B = C$, $D = E = F = 0$, and $\frac{G^2 + H^2 + I^2 - 4AK}{A^2}$ is positive.

This is proved by comparing (III) with (II).

PROBLEMS

1. Find the equation of the sphere whose center is the point

(a) $(\alpha, 0, 0)$ and whose radius is α . *Ans.* $x^2 + y^2 + z^2 - 2\alpha x = 0$.

(b) $(0, \beta, 0)$ and whose radius is β . *Ans.* $x^2 + y^2 + z^2 - 2\beta y = 0$.

(c) $(0, 0, \gamma)$ and whose radius is γ . *Ans.* $x^2 + y^2 + z^2 - 2\gamma z = 0$.

2. Determine the nature of the loci of the following equations and find the center and radius if the locus is a sphere, or the coördinates of the point-sphere if the locus is a point-sphere.

(a) $x^2 + y^2 + z^2 - 6x + 4z = 0$. (c) $x^2 + y^2 + z^2 + 4x - z + 7 = 0$.

(b) $x^2 + y^2 + z^2 + 2x - 4y - 5 = 0$. (d) $x^2 + y^2 + z^2 - 12x + 6y + 4z = 0$.

3. Where will the center of (II) lie if

(a) $G = 0?$ (c) $I = 0?$ (e) $H = I = 0?$

(b) $H = 0?$ (d) $G = H = 0?$ (f) $I = G = 0?$

4. Show that a sphere is determined by four conditions and formulate a rule by which to find its equation.

5. Find the equation of the sphere which

(a) has the center $(3, 0, -2)$ and passes through $(1, 6, -5)$.

Ans. $x^2 + y^2 + z^2 - 6x + 4z - 36 = 0$.

(b) passes through the points $(0, 0, 0)$, $(0, 2, 0)$, $(4, 0, 0)$, and $(0, 0, -6)$.

Ans. $x^2 + y^2 + z^2 - 4x - 2y + 6z = 0$.

(c) has its center on the Y -axis and passes through the points $(0, 2, 2)$ and $(4, 0, 0)$.

Ans. $x^2 + y^2 + z^2 + 4y - 16 = 0$.

(d) passes through the points $(1, 1, 0)$, $(0, 1, 1)$, and $(1, 0, 1)$ and whose radius is 11.

Ans. $x^2 + y^2 + z^2 - 14x - 14y - 14z + 26 = 0$.

(e) has the line joining $(4, -6, 5)$ and $(2, 0, 2)$ as a diameter.

Ans. $x^2 + y^2 + z^2 - 6x + 6y - 7z + 18 = 0$.

6. Given two spheres $S_1 : x^2 + y^2 + z^2 + G_1x + H_1y + I_1z + K_1 = 0$ and $S_2 : x^2 + y^2 + z^2 + G_2x + H_2y + I_2z + K_2 = 0$; show that the locus of

$$S_k : x^2 + y^2 + z^2 + G_1x + H_1y + I_1z + K_1 + k(x^2 + y^2 + z^2 + G_2x + H_2y + I_2z + K_2) = 0$$

is a circle except when $k = -1$. In this case the locus is a plane called the radical plane of S_1 and S_2 .

7. The center of the sphere S_k in problem 6 lies on the line of centers of S_1 and S_2 and divides it into segments whose ratio is equal to k .

8. The equation of the radical plane of S_1 and S_2 (problem 6) is

$$(G_1 - G_2)x + (H_1 - H_2)y + (I_1 - I_2)z + (K_1 - K_2) = 0.$$

9. The radical plane of two spheres is perpendicular to their line of centers.

10. The radical planes of three spheres taken by pairs intersect in a line perpendicular to their plane of centers which is called the radical axis of the spheres.

11. The radical planes of four spheres taken by pairs intersect in a point called the radical center of the spheres.

12. When two spheres S_1 and S_2 (problem 6) intersect, the system S_k consists of all spheres passing through their circle of intersection.

13. When the spheres S_1 and S_2 (problem 6) are tangent, the system S_k consists of all spheres tangent to S_1 and S_2 at their point of tangency.

14. The equation of the system S_k (problem 6) may be written in the form

$$x^2 + y^2 + z^2 + k'x + K = 0,$$

where k' is an arbitrary constant, if the X -axis is chosen as the line of centers and the YZ -plane as the radical plane of S_1 and S_2 .

15. The spheres of the system in problem 14 have their centers on the X -axis and

(a) pass through the circle $y^2 + z^2 + K = 0$, $x = 0$ if $K < 0$.

(b) are tangent to each other at the origin if $K = 0$.

(c) are orthogonal to the sphere $x^2 + y^2 + z^2 = K$ if $K > 0$.

16. The product of a secant of a sphere drawn from a fixed point and its external segment is constant.

17. Find the square of the length of a tangent from a point $P_1(x_1, y_1, z_1)$ to the sphere $x^2 + y^2 + z^2 + Gx + Hy + Iz + K = 0$.

$$\text{Ans. } x_1^2 + y_1^2 + z_1^2 + Gx_1 + Hy_1 + Iz_1 + K.$$

18. Show that the equations of an inversion (p. 297) in space are

$$x = \frac{x'}{x'^2 + y'^2 + z'^2}, \quad y = \frac{y'}{x'^2 + y'^2 + z'^2}, \quad z = \frac{z'}{x'^2 + y'^2 + z'^2}.$$

19. Show that the inverse of a plane is a sphere unless the plane passes through the origin, and that in this case the plane is invariant.

20. Show that the inverse of a sphere is a sphere unless it passes through the origin, when the inverse is a plane.

166. Cylinders.

Ex. 1. Determine the nature of the locus of $y^2 = 4x$.

Solution. The intersection of the surface with a plane parallel to the YZ -plane, $x = k$, are the lines (Rule, p. 345)

$$(1) \quad x = k, \quad y = \pm 2\sqrt{k},$$

which are parallel to the Z -axis (Theorem II, p. 342). If $k > 0$, the locus of equations (1) is a pair of lines; if $k = 0$, it is a single line (the Z -axis); and if $k < 0$, equations (1) have no locus.

Similarly, the intersection with a plane parallel to the ZX -plane, $y = k$, is a straight line whose equations are (Rule, p. 345)

$$x = \frac{1}{4}k^2, \quad y = k,$$

and which is therefore parallel to the Z -axis.

The intersection with a plane parallel to the XY -plane is the parabola

$$z = k, \quad y^2 = 4x.$$

For different values of k these parabolas are equal and placed one above another.

It is therefore evident that the surface is a cylinder whose elements are parallel to the Z -axis and intersect the parabola in the XY -plane

$$y^2 = 4x, \quad z = 0.$$

It is evident from Ex. 1 that the locus of any equation which contains but two of the variables x , y , and z will intersect planes parallel to two of the coördinate planes in one or more straight lines parallel to one of the axes and planes parallel to the third coördinate plane in equal curves. Such a surface is evidently a cylinder. Hence

Theorem IV. *The locus of an equation in which one variable is lacking is a cylinder whose elements are parallel to the axis along which that variable is measured.*

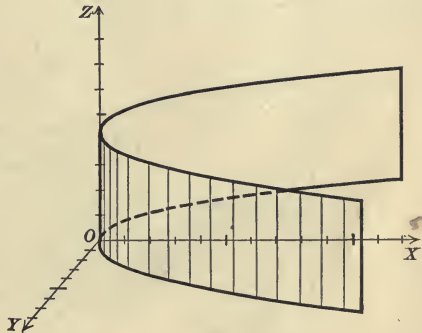

167. The projecting cylinders of a curve. The cylinders whose elements intersect a given curve and are parallel to one of the coordinate axes are called the **projecting cylinders** of the curve. Their equations may be found by eliminating in turn each of the variables x , y , and z from the equations of the curve; for if we eliminate z , for example, the result is the equation of a cylinder (Theorem IV) which passes through the curve, since values of x , y , and z which satisfy each of two equations satisfy an equation obtained from them by eliminating one variable.

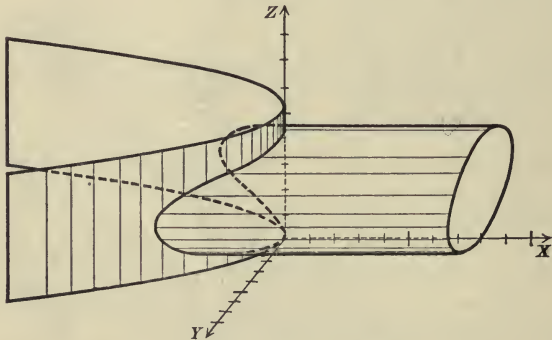

The equations of two of the projecting cylinders may be conveniently used as the equations of the curve.*

The figure shows the curve whose equations are

$$2y^2 + z^2 + 4x = 4z, \quad y^2 + 3z^2 - 8x = 12z.$$

Eliminating x , y , and z in turn, we obtain the equations of the projecting cylinders

$$y^2 + z^2 = 4z, \quad z^2 - 4x = 4z, \quad y^2 + 4x = 0.$$

The figure shows the first and third of these cylinders.

If the curve lies in a plane parallel to one of the coordinate planes, then two of these cylinders coincide with the plane of the curve, or part of it.

* In general, the equations of a curve may be replaced by any two independent equations to which they are equivalent, that is, by two independent equations which are satisfied by all values of x , y , and z satisfying the equations of the curve, and only by such values.

The projecting cylinders of a straight line are evidently planes. The equations of a line in terms of its projecting cylinders or planes have already been given (Theorem IV, p. 367).

168. Cones.

Ex. 1. Determine the nature of the locus of the equation $16x^2 + y^2 - z^2 = 0$.

Solution. Let $P_1(x_1, y_1, z_1)$ be a point on a curve C in which the locus intersects any plane, for example $z = k$. Then

$$(1) \quad 16x_1^2 + y_1^2 - z_1^2 = 0, \quad z_1 = k.$$

The origin O lies on the surface (Theorem III, p. 345). We shall show that the line OP_1 lies entirely on the surface. The direction cosines of OP_1 are (Corollaries, pp. 332 and 331) $\frac{x_1}{\rho_1}$, $\frac{y_1}{\rho_1}$, and $\frac{z_1}{\rho_1}$, where $\rho_1^2 = x_1^2 + y_1^2 + z_1^2 = OP_1^2$. Hence the coordinates of any point on OP_1 are (Theorem V, p. 369)

$$x = \frac{x_1}{\rho_1} \rho, \quad y = \frac{y_1}{\rho_1} \rho, \quad z = \frac{z_1}{\rho_1} \rho.$$

Substituting these values of $x, y,$ and z in the given equation, we obtain

$$(2) \quad 16 \frac{x_1^2 \rho^2}{\rho_1^2} + \frac{y_1^2 \rho^2}{\rho_1^2} - \frac{z_1^2 \rho^2}{\rho_1^2} = 0.$$

This is true for all values of ρ since it may be obtained from the first of equations (1) by multiplying by $\frac{\rho^2}{\rho_1^2}$. Hence every point on OP_1 lies on the surface, that is, the entire line lies on the surface. Hence the surface is a cone whose vertex is the origin.

The essential thing in the solution of Ex. 1 is that (2) may be obtained from the first of equations (1) by multiplying by a power of $\frac{\rho}{\rho_1}$. This may be done whenever the equation of the surface is *homogeneous** in the variables $x, y,$ and z . Hence

Theorem V. *The locus of an equation which is homogeneous in the variables $x, y,$ and z is a cone whose vertex is the origin.*

* An equation is homogeneous in $x, y,$ and z when all the terms in the equation are of the same degree (footnote, p. 17).

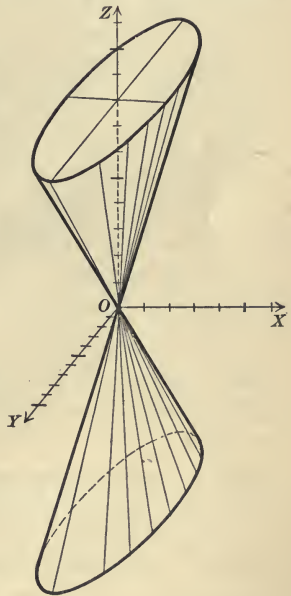

PROBLEMS

1. Determine the nature of the following loci; discuss and construct them.

(a) $x^2 + y^2 = 36$.

(e) $x^2 - y^2 + 36z^2 = 0$.

(b) $x^2 + y^2 = z^2$.

(f) $y^2 - 16x^2 + 4z^2 = 0$.

(c) $y^2 + 4z^2 = 0$.

(g) $x^2 + 16y^2 - 4x = 0$.

(d) $x^2 - z^2 = 16$.

(h) $x^2 + yz = 0$.

2. Find the equations of the cylinders whose directrices are the following curves and whose elements are parallel to one of the axes.

(a) $y^2 + z^2 - 4y = 0, x = 0$.

(c) $b^2x^2 - a^2y^2 = a^2b^2, z = 0$.

(b) $z^2 + 2x = 8, y = 0$.

(d) $y^2 + 2pz = 0, x = 0$.

3. Find the equations of the projecting cylinders of the following curves and construct the curve as the intersection of two of these cylinders.

(a) $x^2 + y^2 + z^2 = 25, x^2 + 4y^2 - z^2 = 0$.

(b) $x^2 + 4y^2 - z^2 = 16, 4x^2 + y^2 + z^2 = 16$.

(c) $x^2 + y^2 = 4z, x^2 - y^2 = 8z$.

(d) $x^2 + 2y^2 + 4z^2 = 32, x^2 + 4y^2 = 4z$.

(e) $y^2 + zx = 0, y^2 + 2x + y - z = 0$.

4. Discuss the following loci.

(a) $x^2 + y^2 = z^2 \tan^2 \gamma$.

(d) $x^2 + y^2 = r^2$.

(b) $y^2 + z^2 = x^2 \tan^2 \alpha$.

(e) $y^2 + z^2 = r^2$.

(c) $z^2 + x^2 = y^2 \tan^2 \beta$.

(f) $z^2 + x^2 = r^2$.

169. Surfaces of revolution. The surface generated by revolving a curve about a line lying in its plane is called a **surface of revolution**.

Ex. 1. Find the equation of the surface of revolution generated by revolving the ellipse $x^2 + 4y^2 - 12x = 0, z = 0$ about the X -axis.

Solution. Let $P(x, y, z)$ be any point on the surface. Pass a plane through P and OX which cuts the surface along one position of the ellipse, and in this

plane draw OY' perpendicular to OX . Referred to OX and OY' as axes, the equation of the ellipse is evidently

(1) $x^2 + 4y'^2 - 12x = 0$.

But from the right triangle PAB we get $y'^2 = y^2 + z^2$.

Substituting in (1), we get

(2) $x^2 + 4y^2 + 4z^2 - 12x = 0$.

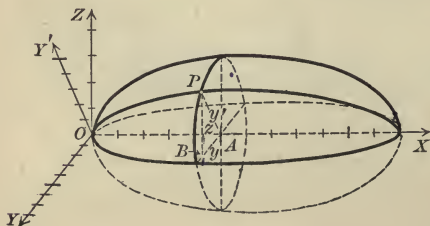

This equation expresses the relation which any point on the surface must satisfy, and it is easily shown that any point whose coördinates satisfy equation (2) lies on the surface. It is therefore the equation of the surface.

The method of the solution enables us to state the

Rule to find the equation of the surface generated by revolving a curve in one of the coördinate planes about one of the axes in that plane.

Substitute in the equation of the curve the square root of the sum of the squares of the two variables not measured along the axis of revolution for that one of these two variables which occurs in the equation of the curve.

If the intersections of a surface with all planes parallel to one of the coördinate planes are circles, then the surface is evidently a surface of revolution whose axis is the coördinate axis perpendicular to the planes of the circular sections. This enables us to determine whether or not a given surface is a surface of revolution whose axis is one of the coördinate axes.

170. Ruled surfaces. A surface generated by a moving straight line is called a **ruled surface**. If the equations of a straight line involve an arbitrary constant, then the equations represent a system of lines which form a ruled surface. If we eliminate the parameter from the equations of the line, the result will be the equation of the ruled surface.

For if (x_1, y_1, z_1) satisfy the given equations for some value of the parameter, they will satisfy the equation obtained by eliminating the parameter, that is, the coördinates of every point on every line of that system satisfy that equation.

Cylinders and cones are the simplest ruled surfaces.

Ex. 1. Find the equation of the surface generated by the line whose equations are

$$x + y = kz, \quad x - y = \frac{1}{k}z.$$

Solution. We may eliminate k from these equations of the line by multiplying them. This gives

$$(1) \quad x^2 - y^2 = z^2.$$

This is the equation of a cone (Theorem V, p. 385) whose vertex is the origin. As the sections made by the planes $x = k$ are circles, it is a cone of revolution whose axis is the X -axis.

We may verify that the given line lies on the surface (1) for all values of k as follows:

Solving the equations of the line for x and y in terms of z , we get

$$x = \frac{1}{2} \left(k + \frac{1}{k} \right) z, \quad y = \frac{1}{2} \left(k - \frac{1}{k} \right) z.$$

Substituting in (1), we obtain

$$\frac{1}{4} \left(k + \frac{1}{k} \right)^2 z^2 - \frac{1}{4} \left(k - \frac{1}{k} \right)^2 z^2 = z^2,$$

an equation which is true for all values of k and z , as is seen by removing the parentheses. Hence every point on any line of the system lies on (1), since its coordinates satisfy (1).

Ex. 2. Determine the nature of the surface $z^3 - 3zx + 8y = 0$.

Solution. The intersection of the surface with the plane $z = k$ is the straight line (Rule, p. 345)

$$k^3 - 3kx + 8y = 0, \quad z = k.$$

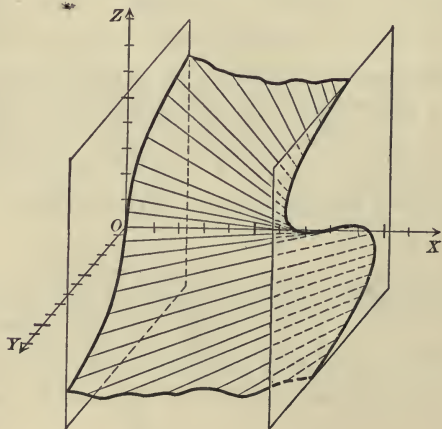

Hence the surface is the ruled surface generated by this line as k varies. To construct the surface consider the intersections with the planes $x = 0$ and $x = 8$ whose equations are respectively

$$x = 0, \quad 8y + z^3 = 0 \quad \text{and} \quad x = 8, \quad 8y - 24z + z^3 = 0.$$

Joining the points on these curves which have the same value of z gives the lines generating the surface.

PROBLEMS

1. Find the equations of the surfaces of revolution generated by revolving the following curves about the axes indicated, and construct the figures.

- (a) $y^2 = 4x - 16$, X -axis. *Ans.* $y^2 + z^2 = 4x - 16$.
 (b) $x^2 + 4y^2 = 16$, Y -axis. *Ans.* $x^2 + 4y^2 + z^2 = 16$.
 (c) $x^2 = 4z$, Z -axis. *Ans.* $x^2 + y^2 = 4z$.
 (d) $x^2 - y^2 = 16$, Y -axis. *Ans.* $x^2 - y^2 + z^2 = 16$.
 (e) $x^2 - y^2 = 16$, X -axis. *Ans.* $x^2 - y^2 - z^2 = 16$.
 (f) $y^2 + z^2 = 25$, Z -axis. *Ans.* $x^2 + y^2 + z^2 = 25$.
 (g) $y^2 = 2pz$, Z -axis. *Ans.* A paraboloid of revolution, $x^2 + y^2 = 2pz$.
 (h) $\frac{x^2}{a^2} + \frac{y^2}{b^2} = 1$, X -axis. *Ans.* An ellipsoid of revolution, $\frac{x^2}{a^2} + \frac{y^2}{b^2} + \frac{z^2}{b^2} = 1$.
 (i) $\frac{x^2}{a^2} - \frac{y^2}{b^2} = 1$, Y -axis. *Ans.* An hyperboloid of revolution of one sheet, $\frac{x^2}{a^2} - \frac{y^2}{b^2} + \frac{z^2}{a^2} = 1$.
 (j) $\frac{x^2}{a^2} - \frac{y^2}{b^2} = 1$, X -axis. *Ans.* An hyperboloid of revolution of two sheets, $\frac{x^2}{a^2} - \frac{y^2}{b^2} - \frac{z^2}{b^2} = 1$.

2. Show that the following loci are either surfaces of revolution or ruled surfaces whose generators are parallel to one of the coördinate planes. Construct and discuss the loci.

- (a) $y^2 + z^2 = 4x$. (e) $4x^2 + 4y^2 - z^2 = 16$.
 (b) $x^2 - 4y^2 + z^2 = 0$. (f) $x^2y - z^2 = 0$.
 (c) $z^2 - zx + y = 0$. (g) $x^2 + z^2 = 4$.
 (d) $x^2y + xz = y$. (h) $(x^2 + z^2)y = 4a^2(2a - y)$.

3. Verify analytically that a sphere is generated by revolving a circle about a diameter.

4. Show that the systems of spheres in problem 15, p. 382, may be generated by revolving the systems of circles in Theorem VIII, p. 144, about the X -axis.

5. Find the equation of the surface of revolution generated by revolving the circle $x^2 + y^2 - 2ax + a^2 - r^2 = 0$ about the Y -axis. Discuss the surface when $\alpha > r$, $\alpha = r$, and $\alpha < r$.

Ans. $(x^2 + y^2 + z^2 + \alpha^2 - r^2)^2 = 4\alpha^2(x^2 + z^2)$. When $\alpha > r$ the surface is called an anchor ring or torus.

6. Find the equations of the ruled surfaces whose generators are the following systems of lines, and discuss the surfaces.

- (a) $x + y = k$, $k(x - y) = a^2$. *Ans.* $x^2 - y^2 = a^2$.
 (b) $4x - 2y = kz$, $k(4x + 2y) = z$. *Ans.* $16x^2 - 4y^2 = z^2$.
 (c) $x - 2y = 4kz$, $k(x - 2y) = 4$. *Ans.* $x^2 - 4y^2 = 16z$.
 (d) $x + ky + 4z = 4k$, $kx - y - 4kz = 4$. *Ans.* $x^2 + y^2 - 16z^2 = 16$.

7. Find the equation of the cone whose vertex is the origin and whose elements cut the circle $x^2 + y^2 = 16$, $z = 2$. *Ans.* $x^2 + y^2 - 4z^2 = 0$.

8. Find the equations of the cones of revolution whose axes are the coördinate axes and whose elements make an angle of ϕ with the axis of revolution. *Ans.* $y^2 + z^2 = x^2 \tan^2 \phi$; $z^2 + x^2 = y^2 \tan^2 \phi$; $x^2 + y^2 = z^2 \tan^2 \phi$.

9. Find the equations of the cylinders of revolution whose axes are the coördinate axes and whose radii equal r .

Ans. $y^2 + z^2 = r^2$; $z^2 + x^2 = r^2$; $x^2 + y^2 = r^2$.

CHAPTER XXI

TRANSFORMATION OF COÖRDINATES. DIFFERENT SYSTEMS OF COÖRDINATES

171. Translation of the axes.

Theorem I. *The equations for translating the axes to a new origin $O'(h, k, l)$ are*

$$(I) \quad x = x' + h, \quad y = y' + k, \quad z = z' + l.$$

Proof. Let the coördinates of any point before and after the translation of the axes be (x, y, z) and (x', y', z') respectively. Projecting OP and $OO'P$ on each of the axes (Theorem II, p. 328), we get equations (I). Q. E. D.

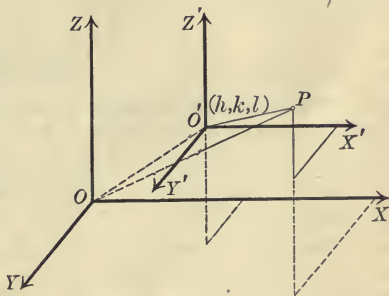

172. Rotation of the axes.

Theorem II. *If $\alpha_1, \beta_1, \gamma_1$; $\alpha_2, \beta_2, \gamma_2$, and $\alpha_3, \beta_3, \gamma_3$ are respectively the direction angles of three mutually perpendicular lines OX', OY' , and OZ' , then the equations for rotating the axes to the position $O-X'Y'Z'$ are*

$$(II) \quad \begin{cases} x = x' \cos \alpha_1 + y' \cos \alpha_2 + z' \cos \alpha_3, \\ y = x' \cos \beta_1 + y' \cos \beta_2 + z' \cos \beta_3, \\ z = x' \cos \gamma_1 + y' \cos \gamma_2 + z' \cos \gamma_3. \end{cases}^*$$

* By Theorem III, p. 330, and Theorem VI, p. 335, we see that the direction cosines of OX', OY' , and OZ' satisfy the six equations

$$\begin{aligned} \cos^2 \alpha_1 + \cos^2 \beta_1 + \cos^2 \gamma_1 &= 1, & \cos \alpha_1 \cos \alpha_2 + \cos \beta_1 \cos \beta_2 + \cos \gamma_1 \cos \gamma_2 &= 0, \\ \cos^2 \alpha_2 + \cos^2 \beta_2 + \cos^2 \gamma_2 &= 1, & \cos \alpha_2 \cos \alpha_3 + \cos \beta_2 \cos \beta_3 + \cos \gamma_2 \cos \gamma_3 &= 0, \\ \cos^2 \alpha_3 + \cos^2 \beta_3 + \cos^2 \gamma_3 &= 1, & \cos \alpha_3 \cos \alpha_1 + \cos \beta_3 \cos \beta_1 + \cos \gamma_3 \cos \gamma_1 &= 0. \end{aligned}$$

Hence only *three* of the nine constants in (II) are independent.

Proof. Let the coördinates of any point P before and after

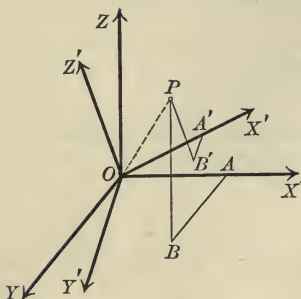

the rotation of the axes be respectively (x, y, z) and (x', y', z') . Projecting OP and $OA'B'P$ on each of the axes OX , OY , and OZ , we get, by Corollary I, p. 328, and Theorems I and II, p. 328, equations (II). Q.E.D.

Theorem III. *The degree of an equation is unchanged by a transformation of coördinates.*

Hint. Show that any transformation of coördinates may be effected by applying Theorems I and II successively, then that the degree cannot be raised by changing to new coördinates, and finally that it cannot be lowered.

PROBLEMS

1. Transform the equation $x^2 + y^2 - 4x + 2y - 4z + 1 = 0$ by translating the origin to the point $(2, -1, -1)$. *Ans.* $x^2 + y^2 - 4z = 0$.

2. Transform the equation $5x^2 + 8y^2 + 5z^2 - 4yz + 8zx + 4xy - 4x + 2y + 4z = 0$ by rotating the axes to a position in which their direction cosines are respectively $\frac{2}{3}, \frac{2}{3}, \frac{1}{3}; \frac{1}{3}, -\frac{2}{3}, \frac{2}{3}; \frac{2}{3}, -\frac{1}{3}, -\frac{2}{3}$. *Ans.* $3x^2 + 3y^2 = 2z$.

3. Formulate a rule by which to simplify a given equation (a) by translating the axes, (b) by rotating the axes. How many terms may, in general, be removed from a given equation by a general transformation of coördinates?

4. Derive the equations for rotating the axes through an angle θ about (a) the Z -axis, (b) the X -axis, (c) the Y -axis.

$$\text{Ans. (a) } \begin{cases} x = x' \cos \theta - y' \sin \theta, \\ y = x' \sin \theta + y' \cos \theta, \\ z = z'. \end{cases}$$

5. Simplify the following equations by translating the axes or by rotating them about one of the coördinate axes.

(a) $x^2 + y^2 - z^2 - 6x - 8y + 10z = 0$. *Ans.* $x^2 + y^2 - z^2 = 0$.

(b) $3x^2 - 8xy - 3y^2 - 5z^2 + 5 = 0$. *Ans.* $x^2 - y^2 + z^2 = 1$.

(c) $y^2 + 4z^2 - 16x - 6y + 16z + 9 = 0$. *Ans.* $y^2 + 4z^2 = 16x$.

(d) $2x^2 - 5y^2 - 5z^2 - 6yz = 0$. *Ans.* $x^2 - 4y^2 - z^2 = 0$.

(e) $9x^2 - 25y^2 + 16z^2 - 24zx - 80x - 60z = 0$. *Ans.* $x^2 - y^2 = 4z$.

6. Show that $Ax + By + Cz + D = 0$ may be reduced to the form $x = 0$ by a transformation of coördinates.

Hint. Remove the constant term by translating the axes, then remove the z -term by rotating the axes about the Y -axis, and finally remove the y -term by rotating about the Z -axis.

7. Show that the xy -term may always be removed from the equation $Ax^2 + By^2 + Cz^2 + Fxy + K = 0$ by a rotation of the axes.

8. Show that the yz -term may always be removed from the equation $Ax^2 + By^2 + Cz^2 + Dyz + K = 0$ by rotating the axes.

9. What are the direction cosines of OX , OY , and OZ (Fig., p. 392) referred to OX' , OY' , and OZ' ? What six equations do they satisfy?

10. Show that the six equations obtained in problem 9 are equivalent to the six equations in the footnote, p. 391.

11. If (x, y, z) and (x', y', z') are respectively the coördinates of a point before and after a rotation of the axes, show that

$$x^2 + y^2 + z^2 = x'^2 + y'^2 + z'^2.$$

173. Polar coördinates. The line OP drawn from the origin to any point P is called the **radius vector** of P . Any point P determines *four* numbers, its radius vector ρ and the direction angles of OP , namely, α , β , and γ , which are called the **polar coördinates** of P .

These numbers are not all independent since α , β , and γ satisfy (III), p. 330. If two are known, the third may then be found, but all three are retained for the sake of symmetry.

Conversely, any set of values of ρ , α , β , and γ which satisfy (III), p. 330, determine a point whose polar coördinates are ρ , α , β , and γ .

Projecting OP on each of the axes, we get, by Corollary I, p. 328, and Theorem I, p. 328,

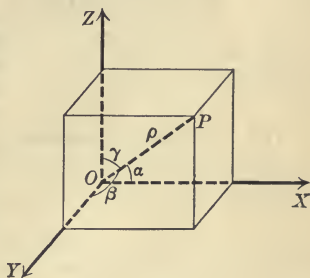

Theorem IV. *The equations of transformation from rectangular to polar coördinates are*

$$(IV) \quad x = \rho \cos \alpha, \quad y = \rho \cos \beta, \quad z = \rho \cos \gamma.$$

From Theorem (IV), p. 331, we obtain

$$(1) \quad \rho^2 = x^2 + y^2 + z^2,$$

which expresses the radius vector in terms of x , y , and z .

174. Spherical coördinates. Any point P determines three numbers, namely, its radius vector ρ , the angle θ between the radius vector and the Z -axis, and the angle ϕ between the projection of its radius vector on the XY -plane and the X -axis. These numbers are called the **spherical coördinates** of P . θ is called the **colatitude** and ϕ the **longitude**.

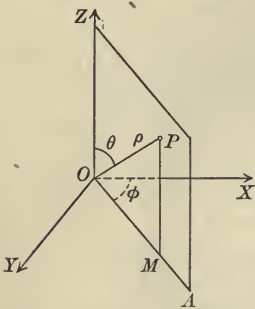

Conversely, given values of ρ , θ , and ϕ determine a point P whose spherical coördinates are (ρ, θ, ϕ) .

Projecting OP on OA , we get

$$OM = \rho \sin \theta,$$

and then projecting OP and OMP on each of the axes, we obtain

Theorem V. *The equations of transformation from rectangular to spherical coördinates are*

$$(V) \quad x = \rho \sin \theta \cos \phi, \quad y = \rho \sin \theta \sin \phi, \quad z = \rho \cos \theta.$$

The equations of transformation from spherical to rectangular coördinates may be obtained by solving (V) for ρ , θ , and ϕ .

175. Cylindrical coördinates. Any point $P(x, y, z)$ determines three numbers, its distance z from the XY -plane and the polar coördinates (r, ϕ) of its projection $(x, y, 0)$ on the XY -plane. These three numbers are called the **cylindrical coördinates** of P . Conversely, three values of r , ϕ , and z determine a point whose cylindrical coördinates are (r, ϕ, z) . From Theorem I, p. 155, we have at once

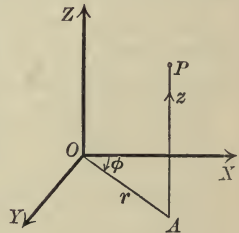

Theorem VI. *The equations of transformation from rectangular to cylindrical coördinates are*

$$(VI) \quad x = r \cos \phi, \quad y = r \sin \phi, \quad z = z.$$

The equations of transformation from cylindrical to rectangular coördinates may be obtained by solving (VI) for r , ϕ , and z .

PROBLEMS

1. What is meant by the "locus of an equation" in the polar coördinates ρ , α , β , and γ ? in the spherical coördinates ρ , θ , and ϕ ? in the cylindrical coördinates r , ϕ , and z ?

2. Show that the locus of an equation in polar coördinates is symmetrical with respect to the pole if only the form of the equation is changed when ρ is replaced by $-\rho$; with respect to one of the coördinate planes if only the form of the equation is changed when α is replaced by $\pi - \alpha$, β by $\pi - \beta$, or γ by $\pi - \gamma$. Under what conditions will it be symmetrical with respect to each of the rectangular axes?

3. Find rules by which to determine when the locus of an equation in spherical or cylindrical coördinates is symmetrical with respect to the origin, each of the rectangular axes, and each of the coördinate planes.

4. How may the intercepts of a surface on the rectangular axes be found if its equation in polar coördinates is given? if its equation in spherical coördinates is given? if its equation in cylindrical coördinates is given?

5. Transform the following equations into polar coördinates.

(a) $x^2 + y^2 + z^2 = 25$.

Ans. $\rho = 5$.

(b) $x^2 + y^2 - z^2 = 0$.

Ans. $\gamma = \frac{\pi}{4}$.

(c) $2x^2 - y^2 - z^2 = 0$.

Ans. $\alpha = \cos^{-1} \frac{1}{3} \sqrt{3}$.

6. Transform the following equations into spherical coördinates.

(a) $x^2 + y^2 + z^2 = 16$.

Ans. $\rho = 4$.

(b) $2x + 3y = 0$.

Ans. $\phi = \tan^{-1}(-\frac{2}{3})$.

(c) $3x^2 + 3y^2 = 7z^2$.

Ans. $\theta = \tan^{-1} \frac{1}{3} \sqrt{21}$.

7. Transform the following equations into cylindrical coördinates.

(a) $5x - y = 0$.

Ans. $\phi = \tan^{-1} 5$.

(b) $x^2 + y^2 = 4$.

Ans. $r = 2$.

8. Find the equation in polar coördinates of

(a) a sphere whose center is the pole.

(b) a cone of revolution whose axis is one of the coördinate axes.

Ans. (a) $\rho = \text{constant}$; (b) $\alpha = \text{constant}$, $\beta = \text{constant}$, or $\gamma = \text{constant}$.

9. Find the equation in spherical coördinates of

(a) a sphere whose center is the origin.

(b) a plane through the Z-axis.

(c) a cone of revolution whose axis is the Z-axis.

Ans. (a) $\rho = \text{constant}$; (b) $\phi = \text{constant}$; (c) $\theta = \text{constant}$.

10. Find the equation in cylindrical coördinates of

(a) a plane parallel to the XY -plane.

(b) a plane through the Z -axis.

(c) a cylinder of revolution whose axis is the Z -axis.

Ans. (a) $z = \text{constant}$; (b) $\phi = \text{constant}$; (c) $r = \text{constant}$.

11. In rectangular coördinates a point is determined as the intersection of three mutually perpendicular planes (p. 326). Show that

(a) in polar coördinates a point is regarded as the intersection of a sphere and three cones of revolution which have an element in common.

(b) in spherical coördinates a point is regarded as the intersection of a sphere, a plane, and a cone of revolution which are mutually orthogonal.

(c) in cylindrical coördinates a point is regarded as the intersection of two planes and a cylinder of revolution which are mutually orthogonal.

12. Show that the square of the distance between two points whose polar coördinates are $(\rho_1, \alpha_1, \beta_1, \gamma_1)$ and $(\rho_2, \alpha_2, \beta_2, \gamma_2)$ is

$$r^2 = \rho_1^2 + \rho_2^2 - 2\rho_1\rho_2(\cos\alpha_1\cos\alpha_2 + \cos\beta_1\cos\beta_2 + \cos\gamma_1\cos\gamma_2).$$

13. Find the general equation of a plane in polar coördinates.

$$\text{Ans. } \rho(A\cos\alpha + B\cos\beta + C\cos\gamma) + D = 0.$$

14. Find the general equation of a sphere in polar coördinates.

$$\text{Ans. } \rho^2 + \rho(G\cos\alpha + H\cos\beta + I\cos\gamma) + K = 0.$$

CHAPTER XXII

QUADRIC SURFACES AND EQUATIONS OF THE SECOND DEGREE IN THREE VARIABLES

176. Quadric surfaces. The locus of an equation of the second degree, of which the most general form is

(1) $Ax^2 + By^2 + Cz^2 + Dyz + Ezx + Fxy + Gx + Hy + Iz + K = 0$,
is called a quadric surface or conicoid.

Theorem I. *The intersection of a quadric with any plane is a conic or a degenerate conic.*

Proof. By a transformation of coördinates any plane may be taken as the XY -plane, $z = 0$, and referred to any axes the equation of a quadric has the form (1) (Theorem III, p. 392). Then the equation of the curve of intersection referred to axes in its plane is (Rule, p. 345)

$$Ax^2 + Fxy + By^2 + Gx + Hy + K = 0,$$

and the locus is therefore a conic or a degenerate conic (Theorem XIII, p. 196). Q. E. D.

Corollary. *The intersection of a cone of revolution with a plane is an ellipse, hyperbola, or parabola according as the plane cuts all of the elements, is parallel to two elements (cutting some on one side of the vertex and some on the other), or is parallel to one element (cutting all the others on the same side of the vertex).*

Theorem II. *The intersections of a quadric with a system of parallel planes are, in general, similar conics.*

Proof. By a transformation of coördinates one of the planes of the system may be taken as the XY -plane, and hence the equation of the system is $z = k$, while that of the quadric has the

form (1) (Theorem III, p. 392). Hence the equation of the curve in which the plane $z = k$ intersects the quadric is (Rule, p. 345)

$$(2) \quad Ax^2 + Fxy + By^2 + (Ek + G)x + (Dk + H)y + Ck^2 + Ik + K = 0.$$

For different values of k this equation represents a system of similar conics* (Corollary I, p. 295). Q. E. D.

177. Simplification of the general equation of the second degree in three variables. If equation (1) be transformed by rotating the axes (Theorem II, p. 391), it can be shown that the new axes may be chosen so that the terms in yz , zx , and xy drop out and hence (1) reduces to the form

$$A'x^2 + B'y^2 + C'z^2 + G'x + H'y + I'z + K' = 0.$$

Transforming this equation by translating the axes (Theorem I, p. 391), it can be shown that the axes may be chosen so that the transformed equation has either the form

$$(1) \quad A''x^2 + B''y^2 + C''z^2 + K'' = 0$$

or the form

$$(2) \quad A''x^2 + B''y^2 + I''z = 0.$$

If all of the coefficients in (1) and (2) are different from zero, (1) and (2) may, with a change in notation, be respectively written in the forms

$$(3) \quad \pm \frac{x^2}{a^2} \pm \frac{y^2}{b^2} \pm \frac{z^2}{c^2} = 1,$$

$$(4) \quad \frac{x^2}{a^2} \pm \frac{y^2}{b^2} = 2cz.$$

* If the invariants of (2) (Theorem VIII, p. 275) for two different values of k are respectively Δ , H , Θ and Δ' , H' , Θ' then in order that the conics be similar the value of λ given by $\frac{H'^3}{\Theta'} = \frac{1}{\lambda^2} \frac{H^3}{\Theta}$ must be a *real* number.

All the sections will belong to the same type because Δ will have the same sign for all values of k . If the sections are ellipses, H and Θ have opposite signs (Theorem IX, p. 277) and λ will be real. The same is true if the sections are parabolas (p. 279). If the sections are hyperbolas, then, in general, for values of k between certain limits the hyperbolas will be similar, and for the remaining values of k , exclusive of the limits, the sections will also be similar (compare problem 3, p. 296).

The purpose of the following sections is to discuss the loci of these equations,* which are called **central** and **non-central quadrics** respectively.

If one or more of the coefficients in (1) or (2) are zero, the locus is called a **degenerate quadric**.

If $K'' = 0$, the locus of (1) is a *cone* (Theorem V, p. 385) unless the signs of A'' , B'' , and C'' are the same, in which case the locus is a *point*, namely, the origin.

If *one* of the coefficients A'' , B'' , and C'' is zero, the locus is a *cylinder* (Theorem IV, p. 383) whose elements are parallel to one of the axes and whose directrix is a conic of the elliptic or hyperbolic type (p. 195). If $K'' = 0$, the locus will be a *pair of intersecting planes* or a *line*.

If *two* of the coefficients A'' , B'' , and C'' are zero, the locus is a *pair of parallel planes* (coincident if $K'' = 0$) or there is *no locus*.

If *one* of the coefficients in (2) is zero, the locus is a *cylinder* (Theorem IV, p. 383) whose directrix is a parabola or a degenerate central conic.

If *two* of the coefficients are zero, the locus is a *pair of coincident planes*. (A'' and B'' cannot be zero simultaneously, as the equation would cease to be of the second degree.)

PROBLEMS

1. Construct and discuss the loci of the following equations.

(a) $9x^2 - 36y^2 + 4z^2 = 0$.

(e) $4y^2 - 25 = 0$.

(b) $16x^2 - 4y^2 - z^2 = 0$.

(f) $3y^2 + 7z^2 = 0$.

(c) $4x^2 + z^2 - 16 = 0$.

(g) $8y^2 + 25z = 0$.

(d) $y^2 - 9z^2 + 36 = 0$.

(h) $z^2 + 16 = 0$.

2. Discuss the locus of the equation $\pm \frac{x^2}{a^2} \pm \frac{y^2}{b^2} \pm \frac{z^2}{c^2} = 0$ (a) if all the signs agree; (b) if two signs are positive. When will the locus be a cone of revolution about the X -axis? the Y -axis? the Z -axis?

3. Show geometrically by means of Theorem I that the sections of a cylinder whose equation is of the second degree made by planes cutting all of the elements are conics of the same type. Show also that the orthogonal projection on a plane of an ellipse is an ellipse; of an hyperbola is an hyperbola; and of a parabola is a parabola.

4. Show how to find the equations of the projections of a curve upon the coördinate planes by means of their projecting cylinders.

5. Prove the Corollary to Theorem I by determining the nature of the intersection of the cone $x^2 + y^2 = \tan^2 \gamma \cdot z^2$ with the plane $x = \tan \beta \cdot z + b$.

6. Prove the Corollary to Theorem I by transforming $x^2 + y^2 = \tan^2 \gamma \cdot z^2$ by rotating the axes about OY through an angle θ and considering the sections formed by the plane $z' = k$ if $\theta \geq \gamma$.

* There is a locus unless all of the coefficients of (3) are negative, when there is no locus.

178. The ellipsoid $\frac{x^2}{a^2} + \frac{y^2}{b^2} + \frac{z^2}{c^2} = 1$. If all of the coefficients in (3), p. 398, are positive, the locus is called an **ellipsoid**. A discussion of its equation gives us the following properties.

1. The ellipsoid is symmetrical with respect to each of the coordinate planes and axes and the origin (Theorem IV, p. 346). These planes of symmetry are called the **principal planes** of the ellipsoid.

2. Its intercepts on the axes are respectively (Rule, p. 346)

$$x = \pm a, \quad y = \pm b, \quad z = \pm c.$$

The lines $AA' = 2a$, $BB' = 2b$, $CC' = 2c$ are called the **axes** of the ellipsoid.

3. Its traces on the principal planes are the ellipses $ABA'B'$, $BCB'C'$, and $ACA'C'$, whose equations are (p. 346)

$$\frac{x^2}{a^2} + \frac{y^2}{b^2} = 1, \quad \frac{y^2}{b^2} + \frac{z^2}{c^2} = 1, \quad \frac{x^2}{a^2} + \frac{z^2}{c^2} = 1.$$

4. The equation of the curve in which a plane parallel to the XY -plane, $z = k$, intersects the ellipsoid is (Rule, p. 345)

$$(1) \quad \frac{x^2}{a^2} + \frac{y^2}{b^2} = 1 - \frac{k^2}{c^2}, \quad \text{or} \quad \frac{x^2}{\frac{a^2}{c^2}(c^2 - k^2)} + \frac{y^2}{\frac{b^2}{c^2}(c^2 - k^2)} = 1.$$

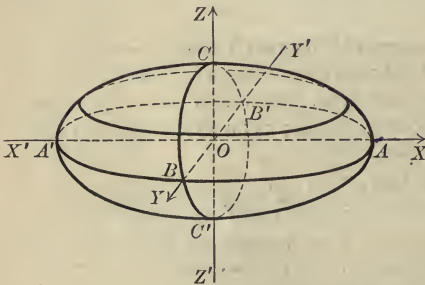

The locus of this equation is an ellipse, and for different values of k the ellipses are similar. If k increases from 0 to c , or decreases from 0 to $-c$, the plane recedes from the XY -plane, and the axes of the ellipse decrease from $2a$ and $2b$ respectively

to 0 when the ellipse degenerates (p. 195). If $k > c$ or $k < -c$, there is no locus, and hence the ellipsoid lies entirely between the planes $z = \pm c$.

PLATE I



Ellipsoid

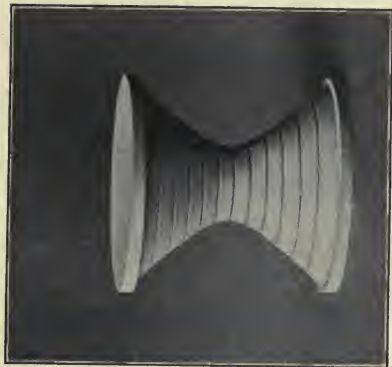

Hyperboloid of one sheet



Hyperboloid of two sheets

CENTRAL QUADRICS

In like manner the sections parallel to the YZ - and ZX -planes are similar ellipses whose axes decrease as the planes recede, and the ellipsoid lies entirely between the planes $x = \pm a$ and $y = \pm b$. Hence the ellipsoid is a closed surface.

If $a = b$, the section (1) is a circle for values of k such that $-c < k < c$, and hence the ellipsoid is an ellipsoid of revolution whose axis is the Z -axis. If $b = c$ or $c = a$, it is an ellipsoid of revolution whose axis is the X - or Y -axis.

If $a = b = c$, the ellipsoid is a sphere, for its equation may be written in the form $x^2 + y^2 + z^2 = a^2$.

179. The hyperboloid of one sheet $\frac{x^2}{a^2} + \frac{y^2}{b^2} - \frac{z^2}{c^2} = 1$. If two of the coefficients in (3), p. 398, are positive and one is negative, the locus is called an **hyperboloid of one sheet**. Consider first the equation

$$(1) \quad \frac{x^2}{a^2} + \frac{y^2}{b^2} - \frac{z^2}{c^2} = 1.$$

A discussion of this equation gives us the following properties.

1. The hyperboloid is symmetrical with respect to each of the coordinate planes and axes and the origin (Theorem IV, p. 346).

2. Its intercepts on the X - and Y -axes are respectively (Rule, p. 346)

$$x = \pm a, \quad y = \pm b,$$

but it does not meet the Z -axis.

3. Its traces on the coordinate planes (p. 346) are the conics

$$\frac{x^2}{a^2} + \frac{y^2}{b^2} = 1, \quad \frac{y^2}{b^2} - \frac{z^2}{c^2} = 1, \quad \frac{x^2}{a^2} - \frac{z^2}{c^2} = 1,$$

of which the first is the ellipse whose axes are $AA' = 2a$ and $BB' = 2b$, and the others are the hyperbolas whose transverse axes are BB' and AA' respectively.

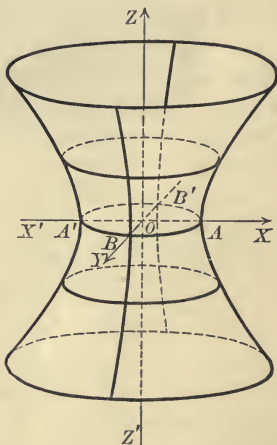

4. The equation of the curve in which a plane parallel to the XY -plane, $z = k$, intersects the hyperboloid is (Rule, p. 345)

$$(2) \quad \frac{x^2}{a^2} + \frac{y^2}{b^2} = 1 + \frac{k^2}{c^2}, \quad \text{or} \quad \frac{x^2}{\frac{a^2}{c^2}(c^2 + k^2)} + \frac{y^2}{\frac{b^2}{c^2}(c^2 + k^2)} = 1.$$

The locus of this equation is an ellipse. If k increases from 0 to ∞ , or decreases from 0 to $-\infty$, the plane recedes from the XY -plane, and the axes of the ellipse increase indefinitely from $2a$ and $2b$ respectively. Hence the surface recedes indefinitely from the XY -plane and from the Z -axis.

In like manner the sections formed by the planes $x = k'$ and $y = k''$ are seen to be hyperbolas. As k' and k'' increase numerically the axes of the hyperbolas decrease, and when $k' = \pm a$ or $k'' = \pm b$, the hyperbolas degenerate into intersecting lines. As k' and k'' increase beyond this point, the directions of the transverse and conjugate axes are interchanged, and the lengths of these axes increase indefinitely.

If either system of hyperbolas is projected orthogonally on the coördinate plane to which the planes of the hyperbolas are parallel, the projected system will have the appearance of the system on p. 201.

The hyperboloid (1) is said to "lie along the Z -axis."

The equations

$$(3) \quad \frac{x^2}{a^2} - \frac{y^2}{b^2} + \frac{z^2}{c^2} = 1, \quad -\frac{x^2}{a^2} + \frac{y^2}{b^2} + \frac{z^2}{c^2} = 1$$

are the equations of hyperboloids of one sheet which lie along the Y - and X -axes respectively.

If $a = b$, the hyperboloid (1) is a surface of revolution whose axis is the Z -axis, because the section (2) becomes a circle. The hyperboloids (3) will be hyperboloids of revolution if $a = c$ and $b = c$ respectively.

180. The hyperboloid of two sheets $\frac{x^2}{a^2} - \frac{y^2}{b^2} - \frac{z^2}{c^2} = 1$. If only one of the coefficients in (3), p. 398, is positive, the locus is called an **hyperboloid of two sheets**. Consider first the equation

$$(1) \quad \frac{x^2}{a^2} - \frac{y^2}{b^2} - \frac{z^2}{c^2} = 1.$$

1. The hyperboloid is symmetrical with respect to each of the coördinate planes and axes and the origin (Theorem IV, p. 346).

2. Its intercepts on the X -axis are $x = \pm a$, but it does not cut the Y - and Z -axes.

3. Its traces on the XY - and XZ -planes (p. 346) are respectively the hyperbolas

$$\frac{x^2}{a^2} - \frac{y^2}{b^2} = 1, \quad \frac{x^2}{a^2} - \frac{z^2}{c^2} = 1,$$

which have the same transverse axis $AA' = 2a$, but it does not cut the YZ -plane.

4. The equation of the curve in which a plane parallel to the YZ -plane, $x = k$, intersects the hyperboloid of one sheet is (Rule, p. 345)

$$\frac{y^2}{b^2} + \frac{z^2}{c^2} = \frac{k^2}{a^2} - 1, \quad \text{or} \quad \frac{y^2}{b^2(k^2 - a^2)} + \frac{z^2}{c^2(k^2 - a^2)} = 1.$$

This equation has no locus if $-a < k < a$. If $k = \pm a$, the locus is a degenerate ellipse, and as k increases from a to ∞ , or decreases from $-a$ to $-\infty$, the locus is an ellipse whose axes increase indefinitely. Hence the surface consists of two branches or sheets which recede indefinitely from the YZ -plane and from the X -axis.

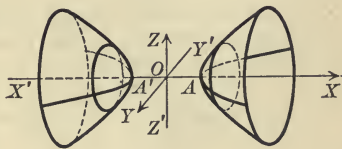

In like manner the sections formed by *all* planes parallel to the XY - and ZX -planes are hyperbolas whose axes increase indefinitely as their planes recede from the coördinate planes.

The hyperboloid (1) is said to “lie along the X -axis.”

The equations

$$(2) \quad -\frac{x^2}{a^2} + \frac{y^2}{b^2} - \frac{z^2}{c^2} = 1, \quad -\frac{x^2}{a^2} - \frac{y^2}{b^2} + \frac{z^2}{c^2} = 1$$

are the equations of hyperboloids of two sheets which lie along the Y - and Z -axes respectively.

If $b = c$, $c = a$, or $a = b$, the hyperboloids (1) and (2) are respectively hyperboloids of revolution.

It should be noticed that *the locus of (3), p. 398, is an ellipsoid if all the terms on the left are positive, an hyperboloid of one sheet if but one term is negative, and an hyperboloid of two sheets if two terms are negative.* If all the terms on the left are negative, there is no locus. If the locus is an hyperboloid, it will lie along the axis corresponding to the term whose sign differs from that of the other two terms.

PROBLEMS

1. Discuss and construct the loci of the following equations.

(a) $4x^2 + 9y^2 + 16z^2 = 144.$

(e) $9x^2 - y^2 + 9z^2 = 36.$

(b) $4x^2 + 9y^2 - 16z^2 = 144.$

(f) $z^2 - 4x^2 - 4y^2 = 16.$

(c) $4x^2 - 9y^2 - 16z^2 = 144.$

(g) $16x^2 + y^2 + 16z^2 = 64.$

(d) $x^2 + 16y^2 + z^2 = 64.$

(h) $x^2 + y^2 - z^2 = 25.$

2. For what values of k or k' will the sections of the hyperboloid of one sheet, $\frac{x^2}{a^2} + \frac{y^2}{b^2} - \frac{z^2}{c^2} = 1$, formed by the planes $x = k$ or $y = k'$ be similar hyperbolas? the hyperboloid of two sheets $-\frac{x^2}{a^2} - \frac{y^2}{b^2} + \frac{z^2}{c^2} = 1$?

3. Show analytically that the intersection of an ellipsoid with any plane is a conic of the elliptic type.

4. Show analytically that the section of an hyperboloid of (a) one sheet, (b) two sheets formed by a plane passing through the axis along which the hyperboloid lies, is an hyperbola.

5. Show that $\frac{x^2}{a^2} + \frac{y^2}{b^2} + \frac{z^2}{c^2} = (Ax + By + Cz)^2$ is the equation of the cone whose vertex is the origin which passes through the intersection of the ellipsoid $\frac{x^2}{a^2} + \frac{y^2}{b^2} + \frac{z^2}{c^2} = 1$ and the plane $Ax + By + Cz = 1$.

6. Show that $x^2\left(\frac{1}{a^2} - \frac{1}{r^2}\right) + y^2\left(\frac{1}{b^2} - \frac{1}{r^2}\right) + z^2\left(\frac{1}{c^2} - \frac{1}{r^2}\right) = 0$ is the equation of the cone whose vertex is the origin which passes through the intersection of the ellipsoid and the sphere $x^2 + y^2 + z^2 = r^2$.

7. If, in problem 6, $a > b > c$ and $r = b$, show that the cone degenerates into a pair of planes whose intersections with the ellipsoid are circles. What is the nature of the cone if $r = a$? if $r = c$?

8. Find the equations of the planes whose intersections with the ellipsoid $9x^2 + 25y^2 + 169z^2 = 1$ are circles.

Ans. $4x = \pm 12z + k.$

9. Find the equation of the cone whose vertex is the origin which passes through the intersection of (a) the hyperboloid of one sheet $\frac{x^2}{a^2} + \frac{y^2}{b^2} - \frac{z^2}{c^2} = 1$, (b) the hyperboloid of two sheets $\frac{x^2}{a^2} - \frac{y^2}{b^2} - \frac{z^2}{c^2} = 1$ with the sphere $x^2 + y^2 + z^2 = r^2$. For what value of r will the cone degenerate into a pair of planes whose intersections with the hyperboloid are circles?

Ans. (a) $x^2\left(\frac{1}{a^2} - \frac{1}{r^2}\right) + y^2\left(\frac{1}{b^2} - \frac{1}{r^2}\right) - z^2\left(\frac{1}{c^2} + \frac{1}{r^2}\right) = 0$; $r = a$ if $a > b$.

(b) $x^2\left(\frac{1}{a^2} - \frac{1}{r^2}\right) - y^2\left(\frac{1}{b^2} + \frac{1}{r^2}\right) - z^2\left(\frac{1}{c^2} + \frac{1}{r^2}\right) = 0$; no real value of r .

10. Find the equations of the two systems of planes whose intersections with (a) an ellipsoid, (b) a hyperboloid of one sheet, (c) a hyperboloid of two sheets, are circles.

181. The elliptic paraboloid $\frac{x^2}{a^2} + \frac{y^2}{b^2} = 2cz$. If the coefficient of y^2 in (4), p. 398, is positive, the locus is called an **elliptic paraboloid**. A discussion of its equation gives us the following properties.

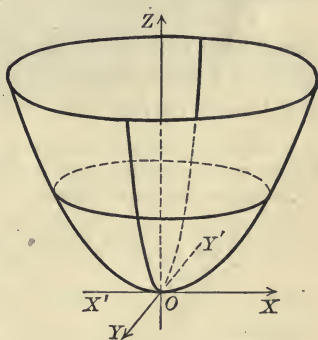

1. The elliptic paraboloid is symmetrical with respect to the YZ - and ZX -planes and the Z -axis (Theorem IV, p. 346).

2. It passes through the origin (Theorem III, p. 345) but does not intersect the axes elsewhere (Rule, p. 346).

3. Its traces on the coordinate planes (p. 346) are respectively the conics

$$\frac{x^2}{a^2} + \frac{y^2}{b^2} = 0, \quad \frac{x^2}{a^2} = 2cz, \quad \frac{y^2}{b^2} = 2cz,$$

of which the first is a degenerate ellipse (p. 195) and the others are parabolas.

4. The equation of the curve in which a plane parallel to the XY -plane, $z = k$, cuts the paraboloid is (Rule, p. 345)

$$\frac{x^2}{a^2} + \frac{y^2}{b^2} = 2ck, \text{ or } \frac{x^2}{2a^2ck} + \frac{y^2}{2b^2ck} = 1.$$

Handwritten notes: $\frac{x^2}{a^2} + \frac{y^2}{b^2} = 2ck$

The curve is an ellipse if c and k have the same sign, but there is no locus if c and k have opposite signs. Hence, if c is positive, the surface lies entirely above the XY -plane. If k increases from 0 to ∞ , the plane recedes from the XY -plane and the axes of the ellipse increase indefinitely. Hence the surface recedes indefinitely from the XY -plane and from the Z -axis.

In like manner the sections parallel to the YZ - and ZX -planes are parabolas whose vertices recede from the XY -plane as their planes recede from the coördinate planes.

The loci of the equations

$$(1) \quad \frac{y^2}{b^2} + \frac{z^2}{c^2} = 2ax, \quad \frac{x^2}{a^2} + \frac{y^2}{c^2} = 2by$$

are elliptic paraboloids which lie along the X - and Y -axes respectively.

If $a = b$, the first surface considered is a paraboloid of revolution whose axis is the Z -axis; and if $b = c$ and $a = c$, the paraboloids (1) are surfaces of revolution whose axes are respectively the X - and Y -axes.

An elliptic paraboloid lies along the axis corresponding to the term of the first degree in its equation, and in the positive or negative direction of the axis according as that term is positive or negative.

182. The hyperbolic paraboloid $\frac{x^2}{a^2} - \frac{y^2}{b^2} = 2cz$. If the coefficient of y^2 in (4), p. 398, is negative, the locus is called an **hyperbolic paraboloid**.

1. The hyperbolic paraboloid is symmetrical with respect to the YZ - and ZX -planes and the Z -axis (Theorem IV, p. 346).

2. It passes through the origin (Theorem III, p. 345) but does not cut the axes elsewhere (Rule, p. 346).

3. Its traces on the coördinate planes (p. 346) are respectively the conics

$$\frac{x^2}{a^2} - \frac{y^2}{b^2} = 0, \quad \frac{x^2}{a^2} = 2cz, \quad -\frac{y^2}{b^2} = 2cz,$$

of which the first is a degenerate hyperbola (p. 195) and the others are parabolas.

4. The equation of the curve in which a plane parallel to the XY -plane, $z = k$, cuts the paraboloid is (Rule, p. 345)

$$\frac{x^2}{a^2} - \frac{y^2}{b^2} = 2ck, \text{ or } \frac{x^2}{2a^2ck} - \frac{y^2}{2b^2ck} = 1.$$

The locus is an hyperbola. If c is positive, the transverse axis of the hyperbola is parallel to the X - or Y -axis according as k is positive or negative. If k increases from 0 to ∞ , or decreases from 0 to $-\infty$, the plane recedes from the XY -plane and the axes of the hyperbolas increase indefinitely. Hence the surface recedes indefinitely from the XY -plane and the Z -axis. The surface has approximately the shape of a saddle.

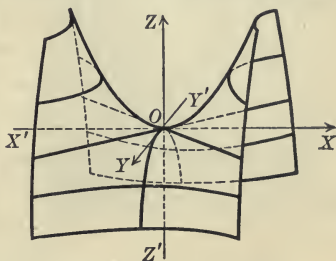

In like manner the sections parallel to the other coördinate planes are parabolas whose vertices recede from the XY -plane as their planes recede from the coördinate planes.

The loci of the equations

$$\frac{x^2}{a^2} - \frac{z^2}{c^2} = 2by, \quad \frac{y^2}{b^2} - \frac{z^2}{c^2} = 2ax$$

are hyperbolic paraboloids lying along the Y - and X -axes respectively.

An hyperbolic paraboloid also lies along the axis which corresponds to the term of the first degree in its equation.

PROBLEMS

1. Discuss and construct the following loci.

(a) $y^2 + z^2 = 4x$.

(c) $9z^2 - 4x^2 = 288y$.

(b) $y^2 - z^2 = 4x$.

(d) $16x^2 + z^2 = 64y$.

2. Prove that the parabolas of the systems obtained by cutting (a) an elliptic paraboloid, (b) an hyperbolic paraboloid by planes parallel to one of the coördinate planes, are all equal.

3. Show analytically that any plane parallel to the axis along which (a) an elliptic paraboloid, (b) an hyperbolic paraboloid lies, intersects the surface in a parabola.

4. Show analytically that any plane not parallel to the axis of an elliptic paraboloid intersects the surface in an ellipse.

5. Show analytically that any plane not parallel to the axis of a hyperbolic paraboloid intersects the surface in a hyperbola.

6. Find the equation of the cone whose vertex is the origin which passes through the intersection of the paraboloid $\frac{x^2}{a^2} + \frac{y^2}{b^2} = 2cz$ and the sphere $x^2 + y^2 + z^2 = 2rz$.

$$\text{Ans. } x^2 \left(\frac{r}{a^2} - c \right) + y^2 \left(\frac{r}{b^2} - c \right) - cz^2 = 0.$$

7. By means of problem 6 find the equations of two systems of planes whose intersections with the paraboloid are circles.

183. Rectilinear generators. The equation of the hyperboloid of one sheet (p. 401) may be written in the form

$$(1) \quad \frac{x^2}{a^2} - \frac{z^2}{c^2} = 1 - \frac{y^2}{b^2}.$$

As this equation is the result of eliminating k from the equations of the system of lines

$$\frac{x}{a} + \frac{z}{c} = k \left(1 + \frac{y}{b} \right), \quad \frac{x}{a} - \frac{z}{c} = \frac{1}{k} \left(1 - \frac{y}{b} \right),$$

the hyperboloid is a ruled surface (p. 387). Equation (1) is also the result of eliminating k from the equations of the system of lines

$$\frac{x}{a} + \frac{z}{c} = k \left(1 - \frac{y}{b} \right), \quad \frac{x}{a} - \frac{z}{c} = \frac{1}{k} \left(1 + \frac{y}{b} \right),$$

and the hyperboloid may therefore be regarded in two ways as a ruled surface.

In like manner the hyperbolic paraboloid contains the two systems of lines

$$\frac{x}{a} + \frac{y}{b} = 2ck, \quad \frac{x}{a} - \frac{y}{b} = \frac{z}{k}$$

and

$$\frac{x}{a} + \frac{y}{b} = kz, \quad \frac{x}{a} - \frac{y}{b} = \frac{2c}{k}.$$

These lines are called the *rectilinear generators* of these surfaces. Hence

Theorem III. *The hyperboloid of one sheet and the hyperbolic paraboloid have two systems of rectilinear generators, that is, they may be regarded in two ways as ruled surfaces.*

PLATE II



Elliptic Paraboloid



Hyperbolic Paraboloid

NON-CENTRAL QUADRICS



Hyperboloid of one sheet



Hyperbolic Paraboloid

RULED QUADRICS

MISCELLANEOUS PROBLEMS

1. Construct the following surfaces and shade that part of the first intercepted by the second.

(a) $x^2 + 4y^2 + 9z^2 = 36$, $x^2 + y^2 + z^2 = 16$.

(b) $x^2 + y^2 + z^2 = 64$, $x^2 + y^2 - 8x = 0$.

(c) $4x^2 + y^2 - 4z = 0$, $x^2 + 4y^2 - z^2 = 0$.

2. Construct the solids bounded by the surfaces (a) $x^2 + y^2 = a^2$, $z = mx$, $z = 0$; (b) $x^2 + y^2 = az$, $x^2 + y^2 = 2ax$, $z = 0$.

3. Show that two rectilinear generators of (a) an hyperbolic paraboloid, (b) an hyperboloid of one sheet, pass through each point of the surface.

4. If a plane passes through a rectilinear generator of a quadric, show that it will also pass through a second generator and that these generators do not belong to the same system.

5. The equation of the hyperboloid of one sheet (p. 401) may be written in the form $\frac{y^2}{b^2} - \frac{z^2}{c^2} = 1 - \frac{x^2}{a^2}$. By treating this equation as we treated equation (1), p. 408, we obtain the equations of two systems of lines on the surface. Show that these systems of lines are identical with those already obtained.

6. Show that a quadric may, in general, be passed through any nine points.

7. If $a > b > c$, what is the nature of the locus of

$$\frac{x^2}{a^2 - \lambda} + \frac{y^2}{b^2 - \lambda} + \frac{z^2}{c^2 - \lambda} = 1$$

if $\lambda > a^2$? if $a^2 > \lambda > b^2$? if $b^2 > \lambda > c^2$? if $\lambda < c^2$?

8. Show that the traces of the system of quadrics in problem 7 are confocal conics.

9. Show that every rectilinear generator of the hyperbolic paraboloid $\frac{x^2}{a^2} - \frac{y^2}{b^2} = 2cz$ is parallel to one of the planes $\frac{x}{a} \pm \frac{y}{b} = 0$.

10. Prove that the projections of the rectilinear generators of (a) the hyperboloid of one sheet, (b) the hyperbolic paraboloid, on the principal planes are tangent to the traces of the surface on those planes.

11. A plane passed through the center and a generator of an hyperboloid of one sheet intersects the surface in a second generator which is parallel to the first.

12. Show how to generate each of the central quadrics by moving an ellipse whose axes are variable.

13. Show how to generate each of the paraboloids by moving a parabola.

CHAPTER XXIII

RELATIONS BETWEEN A LINE AND QUADRIC. APPLICATIONS OF THE THEORY OF QUADRATICS

184. The equation in ρ . Relative positions of a line and quadric. Consider any equation of the second degree, whose locus is a quadric surface, degenerate or non-degenerate, and a line whose parametric equations are (Theorem V, p. 369)

$$(1) \quad x = x_1 + \rho \cos \alpha, \quad y = y_1 + \rho \cos \beta, \quad z = z_1 + \rho \cos \gamma.$$

If these values of x , y , and z satisfy the equation of the quadric, then the point $P(x, y, z)$ on the line (1) will also lie on the quadric. Substituting from (1) in the equation of the quadric and arranging the result according to powers of ρ , the result is a quadratic

$$(2) \quad A\rho^2 + B\rho + C = 0$$

whose roots are the directed distances from $P_1(x_1, y_1, z_1)$ to the points of intersection of the line (1) and the quadric. The quadratic (2) is called the equation in ρ for the given quadric (compare § 94, p. 235). Hence we have the

Rule to derive the equation in ρ for any quadric.

Substitute the values of x , y , and z given by (1) in the equation of the quadric and arrange the result according to powers of ρ .

Denoting the discriminant of (2), $B^2 - 4AC$, by Δ , it is evident from Theorem II, p. 3, that

(a) *the line is a secant of the quadric if Δ is positive.*

(b) *the line is tangent to the quadric if Δ is zero.*

(c) *the line does not meet the quadric if Δ is negative.*

If $C = 0$, one root of (2) is zero (Case I, p. 4), and hence P_1 lies on the quadric.

If $B = 0$, the roots of (2) are numerically equal with opposite signs (Case II, p. 4) and P_1 is the middle point of the chord formed by (1).

If $A = 0$, one root of (2) is infinite (Theorem IV, p. 15) and the line is said to intersect the quadric at infinity.

If $B = C = 0$, both roots are zero (Case III, p. 5) and the line is said to be tangent to the quadric at P_1 .

If $A = B = 0$, both roots are infinite and the line is said to be tangent to the quadric at infinity.

If $A = B = C = 0$, any number is a root of (2), and hence all points on the line lie on the quadric (compare p. 226).

PROBLEMS

1. Determine the relative positions of the following lines and quadrics.

(a) $x = -6 + \frac{2}{3}\rho, y = 6 - \frac{2}{3}\rho, z = 3 - \frac{1}{3}\rho, x^2 + y^2 + 4z^2 = 16.$

Ans. Secant.

(b) $x = \frac{6}{7}\rho, y = 9 + \frac{3}{7}\rho, z = 1 - \frac{2}{7}\rho, y^2 + 4z^2 = 8x.$ *Ans.* Do not meet.

(c) $x = 4 + \frac{2}{3}\rho, y = -2 + \frac{2}{3}\rho, z = 5 + \frac{1}{3}\rho, x^2 + y^2 + z^2 = 36.$

Ans. Tangent.

(d) $x = 3 + \frac{1}{3}\sqrt{3}\rho, y = \frac{5}{2} + \frac{1}{3}\sqrt{3}\rho, z = -2 - \frac{1}{3}\sqrt{3}\rho, x^2 - z^2 = 2y.$

Ans. Line lies on quadric.

(e) $\frac{x-1}{2} = \frac{y}{3} = \frac{z+2}{6}, x^2 + 4y^2 - z^2 - 4x = 0.$ *Ans.* Secant.

(f) $\frac{x-1}{9} = \frac{y}{6} = \frac{z+1}{-5}, x^2 + 4y^2 - 9z^2 = 36.$

Ans. Secant with one point of intersection at infinity.

2. Find the condition that the line $x = 2 + \rho \cos \alpha, y = 1 + \rho \cos \beta, z = -1 + \rho \cos \gamma$ should be tangent to the paraboloid $x^2 - y^2 + 3z = 0.$

Ans. $4 \cos \alpha - 2 \cos \beta - 3 \cos \gamma = 0.$

3. Find the condition that $P_1(x_1, y_1, z_1)$ should be the middle point of the chord of the hyperboloid $x^2 - y^2 + 4z^2 = 16$ formed by the line $x = x_1 + \frac{2}{3}\rho, y = y_1 - \frac{1}{3}\rho, z = z_1 - \frac{2}{3}\rho.$

Ans. $2x_1 + y_1 - 8z_1 = 0.$

185. Tangent planes. Consider the elliptic paraboloid

(1) $\frac{x^2}{a^2} + \frac{y^2}{b^2} = 2cz$

and the line

(2) $x = x_1 + \rho \cos \alpha, y = y_1 + \rho \cos \beta, z = z_1 + \rho \cos \gamma.$

Substituting from (2) in (1), we obtain the equation in ρ (p. 410)

(3) $\left(\frac{\cos^2 \alpha}{a^2} + \frac{\cos^2 \beta}{b^2}\right)\rho^2 + 2\left(\frac{x_1 \cos \alpha}{a^2} + \frac{y_1 \cos \beta}{b^2} - c \cos \gamma\right)\rho + \frac{x_1^2}{a^2} + \frac{y_1^2}{b^2} - 2cz_1 = 0.$

If $P_1(x_1, y_1, z_1)$ is to lie on (1), and (2) is to be tangent to (1) at P_1 , both roots of (3) must be zero, and hence (Case III, p. 5)

(4) $\frac{x_1 \cos \alpha}{a^2} + \frac{y_1 \cos \beta}{b^2} - c \cos \gamma = 0, \frac{x_1^2}{a^2} + \frac{y_1^2}{b^2} - 2cz_1 = 0.$

Solving (2) for the direction cosines, we get

(5) $\cos \alpha = \frac{x - x_1}{\rho}, \cos \beta = \frac{y - y_1}{\rho}, \cos \gamma = \frac{z - z_1}{\rho}.$

Substituting from (5) in the first of equations (4), we get

$$(6) \quad \frac{x_1(x - x_1)}{a^2\rho} + \frac{y(y - y_1)}{b^2\rho} = \frac{c(z - z_1)}{\rho}$$

as the condition that $P(x, y, z)$ should lie on a line tangent to (1) at P_1 . Simplifying (6) by means of the second of equations (4), we obtain

$$(7) \quad \frac{x_1x}{a^2} + \frac{y_1y}{b^2} = c(z + z_1).$$

This is the equation of a plane (Theorem II, p. 349). Hence all of the lines tangent to (1) at P_1 lie in a plane which is called the *tangent plane*.

This method may be summed up in the

Rule to derive the equation of the plane which is tangent to a quadric at a given point $P_1(x_1, y_1, z_1)$.

First step. Derive the equation in ρ and set the coefficient of ρ and the constant term equal to zero.

Second step. Solve the parametric equations of the line for its direction cosines and substitute in the first equation obtained in the first step.

Third step. Simplify the equation obtained in the second step by means of the second equation obtained in the first step. The result is the required equation.

By means of this Rule we obtain

Theorem I. *The equation of the plane which is tangent at $P_1(x_1, y_1, z_1)$ to the central quadric* $\pm \frac{x^2}{a^2} \pm \frac{y^2}{b^2} \pm \frac{z^2}{c^2} = 1$ *is* $\pm \frac{x_1x}{a^2} \pm \frac{y_1y}{b^2} \pm \frac{z_1z}{c^2} = 1$;

non-central quadric $\frac{x^2}{a^2} \pm \frac{y^2}{b^2} = 2cz$ *is* $\frac{x_1x}{a^2} \pm \frac{y_1y}{b^2} = c(z + z_1)$.

Theorem II. *The equation of the plane which is tangent to any quadric at $P_1(x_1, y_1, z_1)$ is found by substituting x_1x , y_1y , and z_1z for x^2 , y^2 , and z^2 ; $\frac{1}{2}(y_1x + x_1y)$, $\frac{1}{2}(z_1y + y_1z)$, and $\frac{1}{2}(x_1z + z_1x)$ for xy , yz , and zx ; and $\frac{1}{2}(x + x_1)$, $\frac{1}{2}(y + y_1)$, and $\frac{1}{2}(z + z_1)$ for x , y , and z in the equation of the quadric.*

186. Polar planes. If P_1 is a point on a quadric, the equation of the tangent plane at P_1 may be found by Theorem II. If P_1 is not on the quadric, the plane found by Theorem II is called the *polar plane* of P_1 , and P_1 is called the *pole* of that plane.

In particular, the polar plane of a point on a quadric is the plane tangent to the quadric at that point, and the pole of a tangent plane is the point of tangency.

187. Circumscribed cones. All of the lines passing through a point not on a given quadric which are tangent to the surface form a cone which is said to be circumscribed about the quadric.

Ex. 1. Find the equation of the cone circumscribed about the ellipsoid $x^2 + 3y^2 + 3z^2 = 9$ whose vertex is the point $P_1(4, -2, 4)$.

Solution. The parametric equations of any line through P_1 are (Theorem V, p. 369)

$$(1) \quad x = 4 + \rho \cos \alpha, \quad y = -2 + \rho \cos \beta, \quad z = 4 + \rho \cos \gamma.$$

Substituting these values of $x, y,$ and z in the equation of the ellipsoid, we obtain the equation in ρ

$$(2) \quad (\cos^2 \alpha + 3 \cos^2 \beta + 3 \cos^2 \gamma) \rho^2 + (8 \cos \alpha - 12 \cos \beta + 24 \cos \gamma) \rho + 67 = 0.$$

If (1) is tangent to the ellipsoid, then [(b), p. 410]

$$(3) \quad (8 \cos \alpha - 12 \cos \beta + 24 \cos \gamma)^2 - 4 \cdot 67 (\cos^2 \alpha + 3 \cos^2 \beta + 3 \cos^2 \gamma) = 0.$$

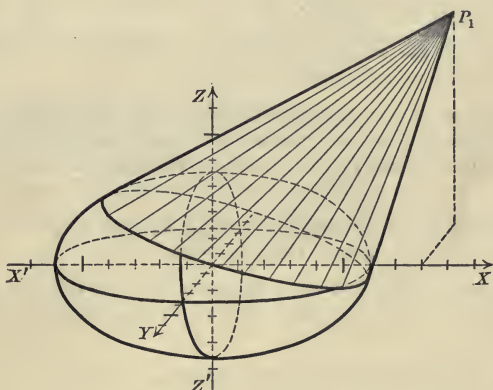

Solving (1) for the direction cosines, substituting in (3), and multiplying by ρ^2 , we get

$$(4) \quad [8(x-4) - 12(y+2) + 24(z-4)]^2 - 268[(x-4)^2 + 3(y+2)^2 + 3(z-4)^2] = 0$$

as the condition that $P(x, y, z)$ should lie on a line passing through P_1 which is tangent to the ellipsoid. Hence (4) is the equation of the required cone.

That the locus of (4) is really a cone whose vertex is P_1 is easily seen by moving the origin to P_1 and applying Theorem V, p. 385.

In constructing the figure, two divisions on each axis were taken for the unit.

The reasoning employed in the solution of Ex. 1 justifies the

Rule to find the equation of the cone whose vertex is $P_1(x_1, y_1, z_1)$ which circumscribes a given quadric.

First step. Derive the equation in ρ and set its discriminant equal to zero.

Second step. In the result of the first step substitute the values of the direction cosines of a line through P_1 obtained from the parametric equations of the line. The result is the required equation.

PROBLEMS

1. Prove that the plane of the two rectilinear generators which pass through any point on a ruled quadric is the tangent plane at that point.

2. Prove that every plane which passes through a rectilinear generator of a ruled quadric is tangent to the quadric at some point of that generator.

3. Prove analytically that every plane tangent to a cone passes through the vertex.

4. Prove that the polar plane of any point in a given plane passes through the pole of that plane.

5. Prove that the pole of any plane which passes through a given point lies in the polar plane of that point.

6. Prove that the curve of contact of a cone circumscribed about a quadric lies in the polar plane of the vertex.

7. Show how to construct (a) the polar plane of a point outside of a quadric, (b) the pole of a plane which cuts the quadric, (c) the polar plane of a point within a quadric, (d) the pole of a plane which does not meet the quadric.

8. Show that the polar plane of a point P_1 with respect to a sphere is perpendicular to the line drawn from the center to P_1 .

9. Show analytically that the polar plane of a point P_1 with respect to a central quadric recedes from the center as P_1 approaches the center, and conversely.

10. Show that the distances from two points to the center of a sphere are proportional to the distances of each of these points from the polar plane of the other.

11. Show how the ideas of "polar reciprocal curves" and "polar reciprocation" with respect to a conic may be generalized to "polar reciprocal surfaces" and "polar reciprocation" with respect to a quadric.

12. What is the polar reciprocal of a cone or cylinder with respect to a sphere? of a plane curve?

13. Generalize problem 7, p. 320, for polar reciprocation with respect to a quadric.

14. Prove that the distance p from the origin to the plane which is tangent to the ellipsoid $\frac{x^2}{a^2} + \frac{y^2}{b^2} + \frac{z^2}{c^2} = 1$ at P_1 is given by $\frac{1}{p^2} = \frac{x_1^2}{a^4} + \frac{y_1^2}{b^4} + \frac{z_1^2}{c^4}$.

15. Prove that the plane $Ax + By + Cz + D = 0$ is tangent to the ellipsoid $\frac{x^2}{a^2} + \frac{y^2}{b^2} + \frac{z^2}{c^2} = 1$ if $A^2a^2 + B^2b^2 + C^2c^2 = D^2$.

16. The locus of the point of intersection of three mutually perpendicular tangent planes to an ellipsoid is a sphere whose radius is $\sqrt{a^2 + b^2 + c^2}$.

Hint. From problem 15 we get the equations of three tangent planes. Square and add these equations, making use of the conditions that the planes shall be mutually perpendicular.

17. Show that the plane $Ax + By + Cz + D = 0$ is tangent to the paraboloid $\frac{x^2}{a^2} \pm \frac{y^2}{b^2} = 2cz$ if $A^2a^2c \pm B^2b^2c = 2CD$.

18. Show that the locus of the point of intersection of three mutually perpendicular tangent planes to a paraboloid is a plane.

The line perpendicular to a plane which is tangent to a surface at the point of tangency is called the **normal** to the surface at that point.

19. Find the equation of the normal to each of the quadrics at a point P_1 .

20. If the normal to an ellipsoid at P_1 meets the principal planes in $A, B,$ and C , then $P_1A, P_1B,$ and P_1C are in a constant ratio.

21. Find the equation of the cone circumscribing a paraboloid whose vertex is $P_1(x_1, y_1, z_1)$.

22. Find the equation of the cylinder circumscribing an ellipsoid if the direction angles of the elements of the cylinder are $\alpha, \beta,$ and γ .

188. Asymptotic directions and cones. If the coefficient of ρ^2 in the equation in ρ for any quadric is zero, one root is infinite (Theorem IV, p. 15), and the line meets the quadric in one point which is at an infinite distance from P_1 . The direction of such a line is called an **asymptotic direction**. It is evident that *a line having an asymptotic direction of a quadric meets the quadric in but one point in the finite part of space.*

It is easily proved that the coefficient of ρ^2 is formed by substituting $\cos \alpha, \cos \beta,$ and $\cos \gamma$ for $x, y,$ and z in the terms of the second degree in the equation of the quadric (compare the footnote, p. 236). Hence the direction cosines of the asymptotic directions of the non-degenerate quadrics

$$\pm \frac{x^2}{a^2} \pm \frac{y^2}{b^2} \pm \frac{z^2}{c^2} = 1, \quad \frac{x^2}{a^2} \pm \frac{y^2}{b^2} = 2cz$$

respectively satisfy the equations

$$(1) \quad \pm \frac{\cos^2 \alpha}{a^2} \pm \frac{\cos^2 \beta}{b^2} \pm \frac{\cos^2 \gamma}{c^2} = 0, \quad \frac{\cos^2 \alpha}{a^2} \pm \frac{\cos^2 \beta}{b^2} = 0.$$

By considering the number of sets of real numbers satisfying these equations for the various combinations of signs we obtain

Theorem III. *The hyperboloids and the hyperbolic paraboloid have an infinite number of asymptotic directions, the elliptic paraboloid has one, and the ellipsoid has none.*

The lines passing through a given point $P_1(x_1, y_1, z_1)$ which have the asymptotic directions of a quadric will, in general, form a cone. The equation of this cone for the hyperboloid of one sheet

$$(2) \quad \frac{x^2}{a^2} + \frac{y^2}{b^2} - \frac{z^2}{c^2} = 1$$

is found as follows. The direction cosines of an asymptotic direction satisfy the equation

$$(3) \quad \frac{\cos^2 \alpha}{a^2} + \frac{\cos^2 \beta}{b^2} - \frac{\cos^2 \gamma}{c^2} = 0. \quad [\text{by (1)}]$$

If the equations of a line through P_1 are

$$(4) \quad x = x_1 + \rho \cos \alpha, \quad y = y_1 + \rho \cos \beta, \quad z = z_1 + \rho \cos \gamma,$$

then

$$(5) \quad \cos \alpha = \frac{x - x_1}{\rho}, \quad \cos \beta = \frac{y - y_1}{\rho}, \quad \cos \gamma = \frac{z - z_1}{\rho}.$$

Substituting in (3) and multiplying by ρ^2 , we get

$$(6) \quad \frac{(x - x_1)^2}{a^2} + \frac{(y - y_1)^2}{b^2} - \frac{(z - z_1)^2}{c^2} = 0$$

as the condition that $P(x, y, z)$ should lie on a line through P_1 which has an asymptotic direction of (2). Hence (6) is the equation of the cone whose vertex is P_1 and whose elements have the asymptotic directions of (2).

That (6) is really the equation of a cone is verified by translating the origin to P_1 .

In general, we have the

Rule to find the equation of the cone of asymptotic directions of a quadric whose vertex is a given point.

Set the coefficient of ρ^2 in the equation in ρ equal to zero, and substitute the values of the direction cosines derived from the parametric equations of the line.

If the coefficients of ρ^2 and ρ in the equation in ρ are both zero, then both roots are infinite* (Theorem IV, p. 15) and the line is called an asymptotic line.

* This assumes that the constant term is not zero. If the constant term is zero, P_1 lies on the quadric, and when the coefficients of ρ^2 and ρ are both zero, any number is a root and the line lies entirely on the quadric.

Let P_1 be any point not on the hyperboloid (2) and let us seek the conditions that α , β , and γ must satisfy if the line (4) is an asymptote.

The equation in ρ for the hyperboloid is

$$\left(\frac{\cos^2 \alpha}{a^2} + \frac{\cos^2 \beta}{b^2} - \frac{\cos^2 \gamma}{c^2}\right) \rho^2 + 2\left(\frac{x_1 \cos \alpha}{a^2} + \frac{y_1 \cos \beta}{b^2} - \frac{z_1 \cos \gamma}{c^2}\right) \rho + \left(\frac{x_1^2}{a^2} + \frac{y_1^2}{b^2} - \frac{z_1^2}{c^2} - 1\right) = 0.$$

If (4) is an asymptote, then, by definition,

$$(7) \quad \frac{\cos^2 \alpha}{a^2} + \frac{\cos^2 \beta}{b^2} - \frac{\cos^2 \gamma}{c^2} = 0, \quad \frac{x_1 \cos \alpha}{a^2} + \frac{y_1 \cos \beta}{b^2} - \frac{z_1 \cos \gamma}{c^2} = 0.$$

These are therefore the conditions which α , β , and γ must satisfy. Equations (7) can be solved for $\cos \alpha$ and $\cos \beta$ in terms of $\cos \gamma$ and there will be two solutions which may be real and unequal, real and equal, or imaginary, and from these we can determine two sets of numbers to which $\cos \alpha$, $\cos \beta$, and $\cos \gamma$ are proportional. Hence there will pass through P_1 either two asymptotes, one, or none.

But if $x_1 = y_1 = z_1 = 0$, that is, if P_1 is the center of the hyperboloid, the second of equations (7) is true for *all* values of α , β , and γ ; and as the first of equations (7) is identical with (3), we see that the elements of the cone of asymptotic directions whose vertex is the center $(0, 0, 0)$ are all asymptotic lines. From (6) the equation of this cone, which is called the *asymptotic cone*, is seen to be

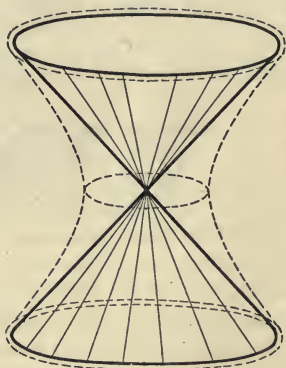

$$\frac{x^2}{a^2} + \frac{y^2}{b^2} - \frac{z^2}{c^2} = 0.$$

Hence we have

Theorem IV. *The equation of the asymptotic cone of the hyperboloid of one sheet*

$$\frac{x^2}{a^2} + \frac{y^2}{b^2} - \frac{z^2}{c^2} = 1 \text{ is } \frac{x^2}{a^2} + \frac{y^2}{b^2} - \frac{z^2}{c^2} = 0.$$

The figure shows the hyperboloid (2) in outline and its asymptotic cone which lies entirely within the surface. As the hyperboloid recedes to infinity it approaches closer and closer to its asymptotic cone in the same way that an hyperbola approaches its asymptotes (Theorem IX, p. 190).

In like manner we may prove the following theorem.

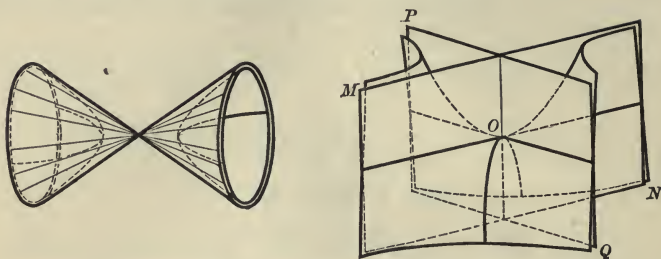

Theorem V. *The equation of the asymptotic cone of the*

hyperboloid of two sheets $\frac{x^2}{a^2} - \frac{y^2}{b^2} - \frac{z^2}{c^2} = 1$ is $\frac{x^2}{a^2} - \frac{y^2}{b^2} - \frac{z^2}{c^2} = 0$;

hyperbolic paraboloid $\frac{x^2}{a^2} - \frac{y^2}{b^2} = 2cz$ is $\frac{x^2}{a^2} - \frac{y^2}{b^2} = 0$.

The latter cone degenerates into a pair of intersecting planes.

PROBLEMS

1. Show that a plane perpendicular to the axis of an hyperbolic paraboloid intersects the surface in an hyperbola whose asymptotes form the intersection of the plane with the asymptotic cone.

2. Show that a plane passing through the axis of an hyperboloid intersects the surface in an hyperbola whose asymptotes form the intersection of the plane with the asymptotic cone.

Hint. Rotate the axes about the axis of the hyperboloid.

3. Show that the asymptotic directions of any quadric are determined by the locus of the equation obtained by setting the terms of the second degree equal to zero.

4. Show that a plane passing through the center and a generator of an hyperboloid of one sheet is tangent to the asymptotic cone.

5. Show that any plane parallel to an element of the asymptotic cone of an hyperboloid intersects the hyperboloid in a parabola.

6. Show that a plane tangent to the asymptotic cone of an hyperboloid cuts the hyperboloid in two parallel lines.

7. Show that every asymptotic line of an hyperboloid is parallel to an element of the asymptotic cone and lies in the plane tangent to the cone along that element.

8. By means of problem 7 show how to construct the asymptotic lines of an hyperboloid which pass through any point P_1 other than the center. Show that there will be two, one, or no asymptotic lines through P_1 according as P_1 is outside of, on, or inside of the asymptotic cone.

9. Show that the hyperboloids $\frac{x^2}{a^2} - \frac{y^2}{b^2} - \frac{z^2}{c^2} = 1$ and $-\frac{x^2}{a^2} + \frac{y^2}{b^2} + \frac{z^2}{c^2} = 1$ have the same asymptotic cone. How are they situated relative to this cone?

10. Show that two asymptotes of an hyperbolic paraboloid pass through every point not on the asymptotic cone, and that each of these lines is parallel to one of the planes which form the cone.

189. Centers. A point $P_1(x_1, y_1, z_1)$ is a center of symmetry of a quadric if it is the middle point of every chord passing through it. In order that P_1 shall be the middle point of a chord, the roots of the equation in ρ must be equal numerically with opposite signs, and hence (Case II, p. 4) the coefficient of ρ must be zero. The coefficient of ρ in the equation in ρ for the general equation of the second degree is easily seen to be

$$(2Ax_1 + Fy_1 + Ez_1 + G)\cos\alpha + (Fx_1 + 2By_1 + Dz_1 + H)\cos\beta + (Ex_1 + Dy_1 + 2Cz_1 + I)\cos\gamma.$$

This is zero for all lines passing through P_1 , that is, for all values of $\cos\alpha$, $\cos\beta$, and $\cos\gamma$, when and only when the three parentheses are zero. *Setting these parentheses equal to zero and solving for x_1 , y_1 , and z_1 , we obtain the coördinates of the center.*

By means of the discussion in § 163, p. 374, we see that a quadric may have a single center, that there may be no center, or that all of the points of a line or of a plane may be centers.

190. Diametral planes. The locus of the middle points of a system of parallel chords of a quadric is found to be a plane which is called a **diametral plane**.

Consider the ellipsoid

$$(1) \quad \frac{x^2}{a^2} + \frac{y^2}{b^2} + \frac{z^2}{c^2} = 1$$

and the system of parallel lines

$$(2) \quad x = x_1 + \rho \cos\alpha, \quad y = y_1 + \rho \cos\beta, \quad z = z_1 + \rho \cos\gamma.$$

These equations represent a system of parallel lines if $x_1, y_1,$ and z_1 are arbitrary while $a, \beta,$ and γ are constant.

The equation in ρ for (1) is

$$(3) \quad \left(\frac{\cos^2\alpha}{a^2} + \frac{\cos^2\beta}{b^2} + \frac{\cos^2\gamma}{c^2}\right)\rho^2 + 2\left(\frac{x_1 \cos\alpha}{a^2} + \frac{y_1 \cos\beta}{b^2} + \frac{z_1 \cos\gamma}{c^2}\right)\rho + \left(\frac{x_1^2}{a^2} + \frac{y_1^2}{b^2} + \frac{z_1^2}{c^2} - 1\right) = 0.$$

If P_1 is the middle point of the chord of (1) formed by the line (2), then the roots of (3) must be numerically equal with opposite signs; and hence (Case II, p. 4)

$$(4) \quad \frac{x_1 \cos \alpha}{a^2} + \frac{y_1 \cos \beta}{b^2} + \frac{z_1 \cos \gamma}{c^2} = 0$$

is the condition that P_1 shall be the middle point of the chord.

But (4) is the condition that P_1 should lie in the plane

$$\frac{x \cos \alpha}{a^2} + \frac{y \cos \beta}{b^2} + \frac{z \cos \gamma}{c^2} = 0,$$

and this is therefore the equation of the locus of the middle points of all chords whose direction angles are α , β , and γ .

By proceeding in this manner with the other quadrics we obtain

Theorem VI. *The equation of the diametral plane bisecting all chords whose direction angles are α , β , and γ of the*

$$\text{central quadric} \quad \pm \frac{x^2}{a^2} \pm \frac{y^2}{b^2} \pm \frac{z^2}{c^2} = 1 \text{ is } \pm \frac{x \cos \alpha}{a^2} \pm \frac{y \cos \beta}{b^2} \pm \frac{z \cos \gamma}{c^2} = 0;$$

$$\text{non-central quadric} \quad \frac{x^2}{a^2} \pm \frac{y^2}{b^2} = 2cz \text{ is } \frac{x \cos \alpha}{a^2} \pm \frac{y \cos \beta}{b^2} = c \cos \gamma.$$

PROBLEMS

1. Determine geometrically the number of centers of each of the types of quadrics and degenerate quadrics.

2. Find the equation of the diametral plane of the locus of the general equation of the second degree bisecting all chords whose direction angles are α , β , γ . From the form of the equation prove that the plane passes through the center of the quadric if there is a center.

3. Prove that every plane through the center of a central quadric or parallel to the axis of a paraboloid is a diametral plane, and find the direction cosines of the chords which it bisects.

4. The line of intersection of two diametral planes is called a **diameter**. Show that a central quadric has three diameters such that the plane of any two bisects all chords parallel to the third. Such lines are called **conjugate diameters**, and the plane of any two is said to be conjugate to the third.

5. Find the equation of the plane which bisects all chords of (a) a central quadric, (b) a paraboloid, which are parallel to the diameter passing through a point P_1 on the quadric.

6. The planes tangent to a quadric at the extremities of a diameter are parallel to the conjugate diametral plane.

7. The sum of the squares of the projections of three conjugate semi-diameters of an ellipsoid on each of the axes of the ellipsoid is constant.

Hint. Let $P_1, P_2,$ and P_3 be the extremities of three conjugate diameters. Find the conditions that these points are on the ellipsoid and that any two are on the plane conjugate to the diameter through the third. Then show that

$$\frac{x_1}{a}, \frac{y_1}{b}, \frac{z_1}{c}, \quad \frac{x_2}{a}, \frac{y_2}{b}, \frac{z_2}{c}, \quad \text{and} \quad \frac{x_3}{a}, \frac{y_3}{b}, \frac{z_3}{c}$$

are the direction cosines of three mutually perpendicular lines, and that if these lines be chosen as axes, then

$$\frac{x_1}{a}, \frac{x_2}{a}, \frac{x_3}{a}, \quad \frac{y_1}{b}, \frac{y_2}{b}, \frac{y_3}{b}, \quad \text{and} \quad \frac{z_1}{c}, \frac{z_2}{c}, \frac{z_3}{c}$$

are also the direction cosines of three lines. Then apply Theorem III, p. 330.

8. By means of problem 7 show that the sum of the squares of three conjugate semi-diameters of an ellipsoid is equal to $a^2 + b^2 + c^2$.

INDEX

- Abscissa, 24
Absolute invariant, 270
Algebraic equation, 17; curve, 72
Anchor ring, 389
Arbitrary constant, 1
Auxiliary circle, 206
- Cardioid, 158, 253, 302
Center of similitude of circles, 296
Central conic, 183; quadric, 399
Cisloid of Diocles, 253, 263, 299
Complete quadrilateral, 123
Conchoid of Nicomedes, 251
Condition for tangency, 230
Confocal conics, 203
Congruent figures, 281
Conicoid, 397
Conjugate diameters of quadrics, 420
Cubical parabola, 72
Curtate cycloid, 259
Cycloid, 256
- Degenerate ellipse, 195; hyperbola, 195; parabola, 196; quadric, 399
Direction cosines of a line, 123, 330, 364
Director circle, 261
Discriminant of the equation of a circle, 131; of the general equation of the second degree, 265; of a quadratic, 2
- Epicycloid, 259
Equations of a transformation, 281
- Euclidean transformation, 281
External angle, 121
- Fixed point, 285
Focal radii of conics, 193, 194
Four-leaved rose, 263
- Graph of an equation, 83
- Homothetic figures, 291
Hyperbolic spiral, 249
Hypocycloid, 259; of four cusps, 257
- Intercepts, 73
Internal angle, 121
Invariant, 270; line, 288; point, 285
Involute of a circle, 259
- Latus rectum, 181
Lemniscate of Bernoulli, 153, 248, 262, 300
Limaçon of Pascal, 253, 262, 302
Limiting points of a system of circles, 144
- Normal to a curve, 210; length of, 214; to a surface, 415
- Ordinate, 24
Orthogonal circles, 143; systems of circles, 308
- Parabolic spiral, 263
Parameter, 1

- Peaucellier's Inversor, 309
Point-circle, 131
Polar reciprocal curves, 313, 317
Prolate cycloid, 259
- Radian, 19
Radical axis, 137, 382
Reciprocal spiral, 249
- Self-conjugate triangles, 319
Semicubical parabola, 209
Spiral of Archimedes, 249
Strophoid, 262, 263, 301
- Subnormal, 214
Subtangent, 214
- Torus, 389
Traces of a surface, 346
Transcendental equation, 17
Transformation, 281
Trisectrix of Maclaurin, 303
- Vertex of a conic, 174, 175
Witch of Agnesi, 250



14 DAY USE
RETURN TO DESK FROM WHICH BORROWED
LOAN DEPT.

This book is due on the last date stamped below, or
on the date to which renewed.
Renewed books are subject to immediate recall.

LIBRARY USE	28Feb'59AJ
FEB 12 1958 26Feb58WW	REC'D LD
REC'D LD	FEB 26 1959
FEB 26 1958 25Mar'58AR	28Mar'60GM
REC'D LD	REC'D LD
MAR 11 1953 6 Dec'58RB	MAR 14 1960
	12 OCT '60RT
REC'D LD	REC'D LD
FEB 9 1950	JAN 20 1961

LD 21A-50m-8,'57
(C8481s10)476B

General Library
University of California
Berkeley

196499

QA551
S62

THE UNIVERSITY OF CALIFORNIA LIBRARY

